

TDC2 Asset Surveyor

Software User Guide

Part Number: 31175-20

Version: 3.30

Revision: A

September 1997

*Trimble Navigation Limited
Mapping & GIS Systems
645 North Mary Avenue
P.O. Box 3642
Sunnyvale, CA 94086
U.S.A.*

*1-800-827-8000 in North America
+1-408-481-8000 International
Fax: +1-408-481-2000*

Trimble Navigation Europe Limited
Trimble House, Meridian Office Park
Osborn Way, Hook
Hampshire RG27 9HX
ENGLAND
+44-1256-760-150
Fax: +44-1256-760-148
Voicemail: +44-1256-761-130

Trimble Navigation Singapore PTE Limited
300 Beach Road
#34-05 The Concourse
Singapore 199555
SINGAPORE
+65-296-2700
Fax: +65-296-8033

Trimble Japan K.K.
Sumitomo Hamamatsu-cho, Building 10F
1-18-16 Hamamatsu-cho Minato-ku
Tokyo 105
JAPAN
+81-3-5472-0880
Fax: +81-3-5472-2326

Trimble Navigation New Zealand Limited
11 Birmingham Drive
P.O. Box 8729 Riccarton
Christchurch
NEW ZEALAND
+64-3-339-1400
Fax: +64-3-339-1417

Copyrights

© 1996–1997 Trimble Navigation Limited. All rights reserved. No part of this manual may be copied, photocopied, reproduced, translated, or reduced to any electronic medium or machine-readable form without prior written consent from Trimble Navigation Limited.

Release Notice

This is Revision A of the September 1997 release of the TDC2 Asset Surveyor Software User Guide, Part Number 31175-20.

Trademarks

ASPEN, and Trimble with the Trimble logo are trademarks of Trimble Navigation, registered in the United States and/or other countries.

4600LS, 7400MSi, ASPEN GPS, ASPEN Pro, Asset Surveyor, Coordinate System Editor, Data Dictionary Editor, DSM, Geodetic Surveyor, Geodetic System Surveyor SSI, *GeoExplorer* II, GIS Surveyor, GIS Surveyor Base Station, GIS Surveyor Rover, GPLoad, GPS Pathfinder Community Base Station, GPS Pathfinder *GeoExplorer*, GPS Pathfinder Pro XL, GPS Pathfinder Pro XR, GPSurvey, GPTrans, Land Surveyor II, Land Surveyor IID, Mobile GPS, NavBeaconXL, Pathfinder Basic, Pathfinder Basic Plus, Pathfinder Office, Pathfinder Professional, Pathfinder ProLite, PFINDER, Phase Processor, ProBeacon, Quick Plan, Series 4000, System Surveyor II, TDC1, TDC2, TANS Vector, TRIMNET Plus, TRIMTALK, TRIMTALK 450, TRIMTALK 900, and TSIP are trademarks of Trimble Navigation Limited.

ARC/INFO, ArcView, and ESRI are trademarks of Environmental Systems Research Industries, Inc. AutoCAD is a trademark of AutoDesk, Inc. IBM is a registered trademark of International Business Machines, Inc. Intel is a trademark of Intel Corporation. MapInfo is a trademark of MapInfo Corporation. Microsoft is a registered trademark, and MS-DOS, Windows, Windows 95, Windows NT, and Windows for Pen Computing are trademarks of Microsoft Corporation. All other brand names are trademarks of their respective holders.

Disclaimer of Warranty

EXCEPT AS INDICATED IN "LIMITED WARRANTY" HEREIN, TRIMBLE HARDWARE, SOFTWARE, FIRMWARE AND DOCUMENTATION IS PROVIDED "AS IS" AND WITHOUT EXPRESS OR LIMITED WARRANTY OF ANY KIND BY EITHER TRIMBLE NAVIGATION LIMITED OR ANYONE WHO HAS BEEN INVOLVED IN ITS CREATION, PRODUCTION, OR DISTRIBUTION INCLUDING BUT NOT LIMITED TO THE IMPLIED WARRANTIES OF MERCHANTABILITY AND FITNESS FOR A PARTICULAR PURPOSE. THE ENTIRE RISK, AS TO THE QUALITY AND PERFORMANCE OF THE TRIMBLE HARDWARE, SOFTWARE, FIRMWARE AND DOCUMENTATION, IS WITH YOU. SOME STATES DO NOT ALLOW THE EXCLUSION OF IMPLIED WARRANTIES, SO THE ABOVE EXCLUSION MAY NOT APPLY TO YOU.

Limitation of Liability

IN NO EVENT WILL TRIMBLE NAVIGATION LIMITED OR ANY PERSON INVOLVED IN THE CREATION, PRODUCTION, OR DISTRIBUTION OF THE TRIMBLE SOFTWARE BE LIABLE TO YOU ON ACCOUNT OF ANY CLAIM FOR ANY DAMAGES, INCLUDING ANY LOST PROFITS, LOST SAVINGS, OR OTHER SPECIAL, INCIDENTAL, CONSEQUENTIAL, OR EXEMPLARY DAMAGES, INCLUDING BUT NOT LIMITED TO ANY DAMAGES ASSESSED AGAINST OR PAID BY YOU TO ANY THIRD PARTY, ARISING OUT OF THE USE, LIABILITY TO USE, QUALITY OR PERFORMANCE OF SUCH TRIMBLE SOFTWARE AND DOCUMENTATION, EVEN IF TRIMBLE NAVIGATION LIMITED OR ANY SUCH PERSON OR ENTITY HAS BEEN ADVISED OF THE POSSIBILITY OF DAMAGES, OR FOR ANY CLAIM BY ANY OTHER PARTY. SOME STATES DO NOT ALLOW THE LIMITATION OR EXCLUSION OF LIABILITY FOR INCIDENTAL OR CONSEQUENTIAL DAMAGES SO, THE ABOVE LIMITATIONS MAY NOT APPLY TO YOU.

Software and Firmware Limited Warranty

Trimble Navigation Limited warrants that Software and Firmware products will substantially conform to the published specifications provided it is used with the Trimble products, computer products, and operating system for which it was designed. For a period of ninety (90) days, commencing thirty (30) days after shipment from Trimble, Trimble also warrants that the magnetic media on which Software and Firmware are distributed and the documentation are free from defects in materials and workmanship. During the ninety (90) day warranty period, Trimble will replace defective media or documentation, or correct substantial program errors at no charge. If Trimble is unable to replace defective media or documentation, or correct program errors, Trimble will refund the price paid for The Software. These are your sole remedies for any breach in warranty.

Hardware Limited Warranty

Trimble Navigation Limited products are warranted against defects in material and workmanship for a period of one year. The warranty period shall commence thirty (30) days after shipment from Trimble's factory. Warranty service will be provided at a designated Trimble Service Center. Trimble will at its option either repair or replace products that prove to be defective. The Customer shall pay all shipping charges for products returned to Trimble for warranty service. Trimble shall pay all shipping charges for the return of products to the Customer.

The above warranty shall not apply to defects resulting from:

1. Improper or inadequate maintenance by the buyer
2. Buyer-supplied software or interfacing
3. Unauthorized modification or misuse
4. Operation outside of the environmental specifications of the product
5. Improper installation, where applicable
6. Lightning or other electrical discharge
7. Fresh or salt water immersion or spray
8. Normal wear and tear on consumable parts (for example, batteries)

No other warranty is expressed or implied. Trimble Navigation Limited specifically disclaims the implied warranties of fitness for a particular purpose and merchantability.

Contents

Preface

1 Introducing the Asset Surveyor

1.1	What is the Asset Surveyor Software?	1-1
1.2	Which Computers does Asset Surveyor run on?	1-2
1.3	What does Asset Surveyor do?	1-3
1.4	Which GPS Receivers does Asset Surveyor work with?	1-5

2 Introducing the TDC2 Datalogger

2.1	What is the TDC2?	2-1
2.2	Turning the TDC2 On and Off	2-2
2.3	Rebooting the TDC2	2-3
2.4	Data Capacity	2-4
2.5	Operating Conditions	2-4
2.5.1	Operating Temperature	2-4
2.5.2	Operating Humidity	2-5
2.5.3	Waterproofing and Dustproofing	2-5
2.5.4	Shockproofing.	2-5
2.6	Storage Conditions	2-6
2.7	Power Sources	2-7
2.7.1	Alternative Power Sources	2-8
2.7.2	Backup Batteries	2-8

Contents

2.8	Keypad	2-9
2.9	Screen.	2-10
2.9.1	Backlight	2-11
2.9.2	Contrast	2-11
2.10	Operating System.	2-11
2.11	Barcode Wand	2-13
2.12	Servicing the TDC2	2-14
3	Installing the Asset Surveyor Software	
3.1	Equipment Required for Upgrading	3-2
3.2	Upgrading the Asset Surveyor Software on your TDC2.	3-3
4	Basics of Operation	
4.1	Starting and Stopping the Asset Surveyor Software	4-1
4.1.1	Starting the Asset Surveyor Software	4-1
4.1.2	Stopping the Asset Surveyor Software.	4-1
4.2	The Asset Surveyor Menu Structure	4-2
4.3	User Interface Components	4-5
4.3.1	Hard Keys	4-5
4.3.2	Softkeys	4-5
4.3.3	Pop-up Messages.	4-6
4.3.4	Pop-up Menus	4-8
4.3.5	Questions.	4-11
4.3.6	Forms.	4-12
4.3.7	Barcodes	4-31
4.4	File Naming Conventions	4-32
4.5	Software and Firmware Version Numbers	4-35

5 Configuring the Asset Surveyor Software

GPS	5-2
Rover Options	5-3
Logging Intervals	5-5
Minimum Positions	5-8
Carrier Phase	5-10
Position Mode	5-14
Elevation Mask	5-17
SNR Mask	5-18
PDOP Mask and PDOP Switch	5-19
Audible Click	5-22
Log DOP Data	5-23
Dynamics Code	5-24
Initial Position	5-26
RTCM Input Options	5-27
Integrated DGPS	5-33
1200	5-33
1200	5-35
Antenna Options	5-39
P(Y) Options	5-43
Output Options	5-47
Base Station Options	5-51
RTCM Output	5-57
Coordinate System	5-62
Selection	5-66
Latitude/Longitude	5-67
UTM	5-68
Other	5-70
Over and Up	5-72
Units and Display	5-74
Units	5-75
Angle Format	5-78

Contents

Order	5-79
Altitude Reference	5-80
North Reference	5-81
Magnetic Declination	5-82
Null String	5-84
Language	5-85
Keypad	5-86
Time and Date	5-87
Quickmarks	5-90
Constant Offsets	5-92
External Sensors	5-96
Sensor 1/2	5-98
Laser	5-111
TDC2 Hardware	5-112

6 GPS Operations Menu

Activating	6-2
Status Line	6-3
2D Altitude	6-7
Almanac	6-8
Operations	6-11
Position	6-13
Receiver Status	6-15
Satellite Information	6-21
DGPS status	6-24
Navigation	6-28
Waypoints	6-29
2D Altitude	6-30
Disconnect	6-32

7 The Main Menu

Data Capture	7-2
Creating Rover Files	7-3
Reopening Rover Files	7-6
Data File Statistics	7-7
Deleting Data Files	7-9
Data Dictionaries	7-11
Starting to Log Data	7-13
Logging Notes	7-15
Starting Features	7-16
Entering Attribute Values	7-19
Saving Features	7-20
Pause and Resume Logging	7-22
Repeating Features	7-24
Quickmarking	7-26
Nested Features	7-30
Segmented Line Features	7-32
Offsets	7-34
External Sensors	7-37
Exiting	7-41
Navigation	7-42
Waypoints	7-47
File Transfer	7-50
Utilities Menu	7-53
Waypoints	7-54
Creating	7-56
Editing	7-58
Deleting	7-60
Measuring Between	7-61

Contents

Factory Defaults	7-63
External Sensors	7-64
Laser	7-69
Reset GPS Receiver	7-72
Almanac	7-74
Upgrading the Asset Surveyor Software	7-75
Base Station	7-76
Creating a File	7-77
Antenna Options	7-79
Reference Position	7-80
Status Form	7-82
Information for New Users	7-84
8 Other Operations	
Reviewing and Editing Data	8-3
Searching	8-6
Positions	8-9
Offsets	8-12
Deleting and Un-deleting	8-17
A Troubleshooting	
B Asset Surveyor Messages	
C Asset Surveyor Limits	
Index	

Preface

Welcome to the *TDC2 Asset Surveyor Software User Guide*. This manual describes how to install, set up, and use the Asset Surveyor™ software, in conjunction with a range of Trimble GPS receivers for GIS data collection and update. The Asset Surveyor software provides all the functionality you need to efficiently capture GIS/GPS data.

Scope and Audience

Even if you have used other Global Positioning System (GPS) products before, we recommend that you spend some time reading this manual to learn about the special features of this product.

The following sections provide you with a guide to this manual, as well as other documentation that you may have received with this product.

Organization

This manual contains the following:

- Chapter 1, Introducing the Asset Surveyor, introduces Trimble's Asset Surveyor software and describes how it enhances GIS data capture using GPS.
- Chapter 2, Introducing the TDC2 Datalogger, contains TDC2 hardware specifications and gives instructions on operating, storing and maintaining the datalogger.
- Chapter 3, Installing the Asset Surveyor Software, contains instructions for the installation and upgrading of the Asset Surveyor software on your TDC2.
- Chapter 4, Basics of Operation, describes the basic concepts you require before being able to make use of the Asset Surveyor system, such as how to select from menus, how to manage data files, etc.
- Chapter 5, Configuring the Asset Surveyor Software, describes how to configure Asset Surveyor for GPS/GIS data capture. This chapter describes, in detail, every function of the Configuration menu.
- Chapter 6, GPS Operations Menu, describes the GPS receiver component of the Asset Surveyor system. This chapter describes, in detail, every function of the GPS operations menu.
- Chapter 7, The Main Menu, describes the functions of data management, navigation, and logging a base station file.
- Chapter 8, Other Operations, describes the functions of Asset Surveyor accessed by the **Note** and **View** keys on the keypad.
- Appendix A, Troubleshooting, describes common problems and how to solve them.

- Appendix B, *Asset Surveyor Messages*, lists, in alphabetical order, the various error, warning and information messages which the Asset Surveyor software may display, and describes each in detail. Refer to this appendix if you do not fully understand what is meant by a certain message.
- Appendix C, *Asset Surveyor Limits*, lists the few practical limitations under which the Asset Surveyor software operates.

How to Use this Manual

Please read the release notes which accompany this manual. They contain last-minute information regarding the Asset Surveyor software and your Trimble GPS receiver.

Check the Trimble Bulletin Board System (BBS) and the Trimble Internet site on a regular basis for application notes and new software release information.

Before using the Asset Surveyor software, you should also read the *GPS Mapping Systems General Reference* manual, *TDC2 Asset Surveyor Operation Manual* and the *Receiver Manual* for your Trimble GPS system.

Related Information

The following sections discuss other sources of information that introduce, extend, or update this manual.

Other Manuals

Asset Surveyor Operation Manual

The *Asset Surveyor Operation Manual* describes how to operate the Asset Surveyor software.

Mapping Systems General Reference

The *Mapping Systems General Reference* explains general GPS and GIS concepts, as well as the Trimble Survey and Mapping Bulletin Board.

Pathfinder Office Manuals

The *Pathfinder Office Getting Started Guide* contains a tutorial chapter explaining how to use many features common to the Pathfinder Office software.

README Files

The disk that you receive containing the Asset Surveyor software has a README file on it. It contains information added after the manuals went to print. Check to see whether there is important information in the README, before you upgrade or run the software for the first time.

Release Notes

Release Notes are provided with the Asset Surveyor software. They can describe new features of the product, the installation procedure, information not included in the manuals, and corrections to the manuals.

How to Avoid Reading this Manual

While you are strongly encouraged to thoroughly read this manual in order to get the best performance from your GIS/GPS data collection system, we realize that you will be very keen to take your new GPS receiver out and ‘test drive’ it immediately. The following paragraphs should enable you to do just that.

Once you have connected your TDC2 to your GPS receiver and connected charged batteries, you can just turn on your GPS receiver and your TDC2. If you have installed your Asset Surveyor software and connected your GPS equipment correctly, the Asset Surveyor software will start to communicate with the GPS receiver. If not, check the appropriate receiver appendix at the back of the *TDC2 Asset Surveyor Operation Manual* or check your receiver’s operation manual, for cabling diagrams and equipment lists.

Once the Asset Surveyor software is communicating with your GPS receiver, you can use the system for capturing geographic data. Asset Surveyor acts as a control panel for the GPS receiver, and can be used to configure the way in which the GPS receiver operates, as described in Chapter 5, Configuring the Asset Surveyor Software. You can also record positions or navigate using the GPS receiver.

In order to record interesting features and attributes, you will need to load a data dictionary onto your TDC2. See the Pathfinder Office documentation for details of how to create a data dictionary. Chapter 7, The Main Menu, of this manual describes how to transfer a data dictionary to your TDC2.

Although the Asset Surveyor software is largely self-explanatory, it is a very versatile and flexible software system, and you will probably only be able to take full advantage of its power after reading this manual thoroughly. Once you have given your Trimble Asset Surveyor and GPS receiver a test-drive, you are encouraged to make a cup of coffee, find a comfortable chair where you won’t be disturbed and read this manual. You may find it useful to refer to your TDC2 as you read.



Note – Even if you are unable to read the whole manual, you are encouraged to always carry the *Asset Surveyor Quick Reference Guide* with you when you are using the Asset Surveyor software. The Quick Reference Guide provides an overview of the system as well as describing a number of important details which may be difficult to remember.

Other Information

This section outlines sources that provide information not necessarily related to this product.

Bulletin Board Service

Use the Trimble Bulletin Board Service (BBS) to obtain daily satellite status reports, technical tips, almanacs, and other bulletins from Trimble. Check it regularly for application notes, new software releases, and other information. Use it to exchange email with Trimble support personnel or other Trimble customers. By arrangement with our customer support technicians, you can transmit problem data files using the BBS.

To access this service, you need a personal computer (PC), a modem, and telecommunications software.

The BBS is in the United States and is reached as follows:

Phone +1-408-481-7800 (set at 8-N-1).

World Wide Web

For an interactive look at Trimble visit our site on the World Wide Web (<http://www.trimble.com>).

FTP Site

Use the Trimble FTP site to send or receive files. The address is <ftp://ftp.trimble.com>. You can also access the FTP site from the Trimble World Wide Web site (<http://www.trimble.com/support/support.htm>).

RTCM

For information on RTCM SC-104, contact:

Radio Technical Commission for Maritime Services
P.O. Box 19 087
Washington, D.C. 20036, U.S.A

Technical Assistance

If you have a problem and cannot find the information you need in the product documentation, ***contact your local dealer***.

If you need further assistance, contact the Trimble Technical Assistance Center (TAC). You can fax or phone them, or send an email. A support technician can help determine the cause of the problem and provide technical assistance. The phone numbers are:

1-800-SOS-4TAC (North America)
+1-408-481-6940 (International)
+1-408-481-6020 (fax)

TAC phones are answered from 6 am to 5.30 pm Pacific Standard Time.

The TAC email address is trimble_support@trimble.com

When you contact TAC, have the following information available:

1. The Trimble product name, any software or firmware version number(s), and if appropriate, the serial number.
2. Your specific question or problem. Please detail background information, such as the configuration of your data logger or receiver, and the exact type, make, and configuration of your computer. If you have received error messages, please specify the exact wording.

If you need to send a data file along with your inquiry, please compress the file using PKZIP Software by PKWARE, Inc., and name the file with the extension .ZIP.

Use one of the following methods to send the file:

- Attach the file to your email inquiry.
- Put the file on the Trimble BBS or the Trimble FTP site and include the filename in your email inquiry.

Reader Comment Form

Thank you for purchasing this Trimble product. At the end of this manual you will find a reader comment form. We appreciate any feedback you have about this manual. If this form is not available, comments and suggestions can be sent to the address in the front of this manual. All comments and suggestions become the property of Trimble Navigation Limited.

Document Conventions

Italics identify software menus, menu commands, dialog boxes, and the dialog box fields.

SMALL CAPITALS identify DOS commands, folders, filenames, and filename extensions.

Courier represents messages printed on the screen.

Courier Bold represents information that you must type in a software screen or window.

Helvetica Bold represents a software command button.

Return or **Ctrl**+**C** is an example of a hardware function key or key combination that you must press on your PC.

Key Symbols

The Asset Surveyor GPS/GIS data collection software uses both *hard* (i.e. physical) keys on a keypad and *soft* (i.e. visual) keys on the datalogger's screen. This manual illustrates these two classes of keys using different symbols.

Hard (physical) keys on the TDC2 keypad are indicated as follows:

, , , etc.

Softkeys on the TDC2 screen are indicated as follows:

, , , etc.

A softkey is activated by pressing the corresponding function key (**F1** ... **F5**) on the TDC2's keypad.

Warnings, Cautions, Notes, and Tips

Warnings, cautions, notes, and tips draw attention to important information, and indicate its nature and purpose.



Warning – Warnings alert you to situations that could cause personal injury or unrecoverable data loss.



Caution – Cautions alert you to situations that could cause hardware damage or software error.



Note – Notes give additional significant information about the subject to increase your knowledge, or guide your actions.



Tip – Tips indicate a shortcut or other time- or labor-saving hint that can help you make better use of the product.

1 Introducing the Asset Surveyor

Congratulations on your purchase of the Trimble Asset Surveyor™ GIS/GPS data collection system. The combination of sophisticated data collection software and GPS positioning hardware enables you to efficiently collect high quality GIS data.

1.1 What is the Asset Surveyor Software?

Asset Surveyor is a software system (that is a computer program) produced by Trimble Navigation Limited, for a wide range of Geographic Information System (GIS) data capture applications.

The Asset Surveyor software works with a range of Global Positioning System (GPS) receivers produced by Trimble Navigation Limited.

1.2 Which Computers does Asset Surveyor run on?

The Asset Surveyor software runs on two powerful hand-held computers:

- The Trimble TDC1™ data collector, which is a lightweight, compact and rugged hand-held computer. The TDC1 also runs Trimble's Survey Controller™ software, and a single TDC1 can be shared between GIS and Land Survey applications. The TDC1 comes in two sizes: the standard TDC1 has 2 MB of memory for captured data, while the expanded TDC1 has 4 MB of memory. Until recently, the standard TDC1 had 1 MB of memory.
- The Trimble TDC2™ data collector. This is an even more rugged hand-held computer than the TDC1, and is completely waterproof. The TDC2 can be used for GIS data capture applications in the most hostile environments. The TDC2 is available with 3 MB of data storage memory. Until recently, the standard TDC2 had 570KB of data storage memory.

1.3 What does Asset Surveyor do?

The primary function of the Asset Surveyor software is the automated capture of information related to geographic features. Together with a Trimble GPS receiver, the Asset Surveyor software can quickly and accurately capture the attributes and GPS position of geographic points, lines and areas. This information is stored in one or more data files, which you can load into Trimble's Pathfinder Office™ software suite. After postprocessing and editing, data can then be output in a wide range of GIS-compatible formats.

Applications for the Asset Surveyor software include forestry mapping, environmental and resource management, disaster assessment, utility inventories and urban asset management. For example, a power company could build an asset register of all its power poles, recording their position to within a meter, and the condition and structure of the poles and any attached hardware. A maintenance crew may later use the Asset Surveyor software's navigation functions in order to locate any poles requiring repair.

You can review, edit or delete, data that has been captured with the Asset Surveyor software right there in the field. This ensures that the data that you capture and take back to the office is correct and complete.

The Asset Surveyor software provides you with convenient and powerful control of your Trimble GPS receiver, enabling you to take full advantage of the potential offered by GPS.

The Asset Surveyor software lets you collect carrier phase data for points, lines, and areas to compute positions to decimeter accuracy with Pathfinder Office v2.00. The Asset Surveyor software, when used with a GPS Pathfinder Pro XR™ or Pro XRS™ receiver, can also collect data to recorrect real-time differential data captured in the field, for greater accuracy.

You can operate the Asset Surveyor software as a temporary GPS Base Station, in situations where a more permanent Base Station is impractical or impossible to set up. In combination with a Pathfinder Pro XRS, Pro XR, or Pro XL GPS receiver, Asset Surveyor can output RTCM messages when operating as a Base station, which can be received by a number of Pathfinder receivers with a suitable radio link.

The Asset Surveyor software lets you use your Trimble GPS receiver for navigation to a waypoint or to a previously-recorded geographic feature.

The Asset Surveyor software provides integrated support for a number of laser rangefinders, which you can use to record offsets to geographical features. The use of offsets makes it possible to capture data in circumstances where the use of GPS alone might be inconvenient or even impossible.

The Asset Surveyor software lets you record information from external sensors, using Trimble's 'External Sensor Potential' (ESPTM) system. The Asset Surveyor software can capture data from a wide range of sensors equipped with an RS232 port. Each reading from the external sensor can be stored as an attribute of a feature, or can have a GPS position associated with it. This lets you correlate information from depth sounders, Geiger counters, tree calipers, etc. with GPS positions.

The Asset Surveyor software has been translated into a number of languages. For each supported language (French, German, Portuguese, Russian and Spanish), all text displayed by Asset Surveyor appears in that language, rather than in English.

1.4 Which GPS Receivers does Asset Surveyor work with?

The TDC2 Asset Surveyor software works with the following Trimble GPS receivers:

- Pathfinder Pro XRS
- Pathfinder Pro XR
- Pathfinder Pro XL
- Military-grade Trimble Centurion™ and Trimpack III™
- The Series 4000 GPS™ receiver family, which includes the 4000SE™, 4000SSE™ and the 4000SSi™.

2 Introducing the TDC2 Datalogger

2.1 What is the TDC2?

The TDC2 is one of the smallest, toughest, MS-DOS compatible computers ever made. It is highly resistant to moisture, dust, vibration, shock and electromagnetic interference, and provides long and trouble-free operation.

The TDC2 is a customized variant of the field-proven Husky FS/2 datalogger, featuring a special-purpose keypad, flash EEPROM for non-volatile program storage and modifications to its power circuitry, memory configuration and ROM.

The TDC2 has 3 MB of memory available for the storage of data. The TDC2 also has 512 kb of EEPROM allocated to program space, and this is where the Asset Surveyor program resides.

2.2 Turning the TDC2 On and Off

To turn the TDC2 on, press the  key (at the top-right of the TDC2 keypad).

To turn the TDC2 off, press  again.

When the Asset Surveyor software is running, you can, in most situations, turn the TDC2 off. When you turn the TDC2 on again, Asset Surveyor will continue where it left off.





Note – You cannot turn the TDC2 off when Asset Surveyor has a data file open, or when transferring files to a PC. You must first close the data file or exit file transfer mode and then turn the TDC2 off.

2.3 Rebooting the TDC2

Under normal circumstances the TDC2 should be very reliable, and you should have no need to reboot the unit.

If the TDC2 ever locks up and will not respond to keypad commands, you can reset the TDC2 (and restart the Asset Surveyor software) by performing the following 'Hardware Reset Procedure':

To Perform a Hardware Reset:

1. While holding down both  keys, press . Hold down all three keys for at least four seconds.
2. The TDC2 should immediately reboot. If it does not, there is a hardware malfunction, contact your Trimble Assistance Center for advice.



Note – This procedure will cause the TDC2 hardware to perform a *warm* boot. No data loss should occur as a result of performing this procedure.

If the Asset Surveyor software does not restart after a reset, the program or some of its auxiliary files may have been lost or corrupted. In this situation, you will need to reinstall the Asset Surveyor software as described in Chapter 3, Installing the Asset Surveyor.

2.4 Data Capacity

The TDC2 supplied by Trimble with GPS Pathfinder systems has 3MB of data storage memory. This is enough memory to store approximately 110,000 GPS positions. If you log data at one position per second, this will be enough for 31 hours of continuous operation.

Since most applications do not require such a high data logging rate, you will probably be able to collect data for several days before you run out of room in the TDC2's memory by logging at a lower rate.



Note – Even though the TDC2 can hold a large amount of data, Trimble recommends that you transfer data files from the TDC2 to your PC daily.



Tip – To increase the length of time for which you can log data to the TDC2's memory, increase the GPS logging intervals (as described on page 5-3).

2.5 Operating Conditions

2.5.1 Operating Temperature

The recommended operating temperature is from -30° to $+55^{\circ}$ C (-22° F to $+130^{\circ}$ F). Below -30° C (-22° F) the LCD screen can become damaged.

Prolonged exposure to temperatures above 60° C (140° F) can damage the unit.

2.5.2 Operating Humidity

The TDC2 is designed to operate in conditions of up to 99% relative humidity. It has an internal dessicator and a visual indicator on the bottom-right of the LCD shows any water ingress (by changing from blue to pink).

2.5.3 Waterproofing and Dustproofing

The TDC2 is designed to resist the ingress of water and dust, to standard IP67 (BS5490). Factory pressure testing assures that leaks do not occur and the unit will normally withstand immersion in up to one meter (39 inches) of water for up to 30 minutes. Immersion characteristics can be impaired by non-Trimble-approved maintenance or modifications, or by impact damage. The most common cause of immersion failure is a loose battery cap.

The TDC2 withstands exposure to rain without ingress of water.

If water is trapped in the keypad area it can lead to progressive keypad failure, exhibited by ‘over-sensitive’ or ‘struck’ keys. To avoid this, drain the unit by storing it vertically in a warm place. Forced drying is not recommended.

If fine dust or liquids (such as coffee) congeal in the keypad and prove difficult to remove, ensure that the battery cap is secure and then rinse the unit carefully in warm running water.

If water is trapped in the connectors, blow it out when convenient.

2.5.4 Shockproofing

The TDC2 is designed to withstand shock and accidental drops from up to 2 m (6 ft) onto a hard surface. It is recommended that repeated abuse be avoided as far as possible.

2.6 Storage Conditions

The permissible storage temperature range is -30°C to $+60^{\circ}\text{C}$ (-22°F to $+140^{\circ}\text{F}$), but as battery life is shorter at higher temperatures Trimble recommends storage at less than 35°C ($+95^{\circ}\text{F}$). Under these conditions, Trimble recommends batteries are replaced at least every 12 months. Data retention is only guaranteed in the range of -30°C to $+60^{\circ}\text{C}$ (-22°F to $+140^{\circ}\text{F}$).



Caution – If stored, the TDC2 *must* be fitted with new, high quality Alkaline batteries.

A serious risk with long-term storage is battery leakage, which can cause very serious damage to the TDC2. Use only the highest quality Alkaline cells for storage and ensure that they are brand new when fitted.

2.7 Power Sources

The TDC2 is shipped with Alkaline batteries. When operating with a GPS receiver, the TDC2 will normally be powered by the receiver's batteries, so discharge of the TDC2's own Alkaline batteries only occurs when the datalogger is used separately from a GPS receiver.



Caution – Lithium batteries should not be fitted to the TDC2 under any circumstances.

To fit the batteries:

1. Turn the TDC2 off.
2. Use a coin to undo the battery cap (on the bottom of the TDC2, in the center).
3. Remove the current cells from the TDC2.
4. Feed the new cells in carefully, positive (+) end first.
5. Take the battery cap, and with finger pressure only, press it into the battery compartment and turn it clockwise.
6. Once the thread is started, use a coin to screw the cap tightly home.

When operating the TDC2 on battery power, the datalogger hardware monitors the level of the TDC2's battery. If the battery power falls too low, a warning message displays:

WARNING BATTERIES ARE LOW

If the battery level falls so low as to endanger the contents of the TDC2's memory, the TDC2 hardware will turn off to preserve the memory. No warning message is displayed.



Tip – If the TDC2 does not turn on when you press , check that its batteries have sufficient charge. If the TDC2 has not been used for some time, the battery levels may have been depleted.

2.7.1 Alternative Power Sources

In the office, you can operate the TDC2 without discharging the internal Alkaline batteries by connecting the supplied adaptor (part number 27996) to your OSM-PF.

2.7.2 Backup Batteries

The TDC2 contains a trickle-charged internal battery which provides sufficient backup power to preserve the contents of the TDC2's memory for at least two weeks, if the main power source is removed.

2.8 Keypad

The TDC2's keypad contains function keys, a full set of alphanumeric keys, cursor motion keys, shift keys and a number of other special keys. The keypad's design enables you to operate of the TDC2 and enter numeric data with one hand.

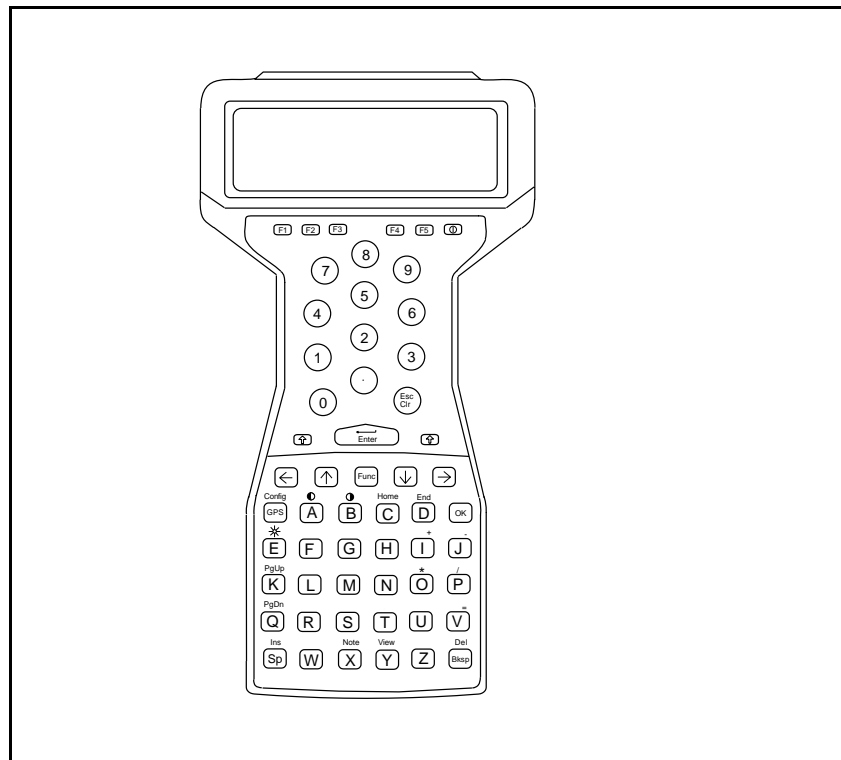

Figure 2-1 The TDC2's Keypad

Usually, when operating the TDC2, single keystrokes perform single actions. Sometimes, however, two keystrokes are required to perform a specific action. When an operation requires two keys, the keys are pressed sequentially. e.g. 'Func' + '0'.

The **Func** key can be used in sequential key combinations with other keys on the TDC2's keypad in order to perform special operations or to type special characters. Figure 2-2 illustrates the various **Func** key operations and special characters.

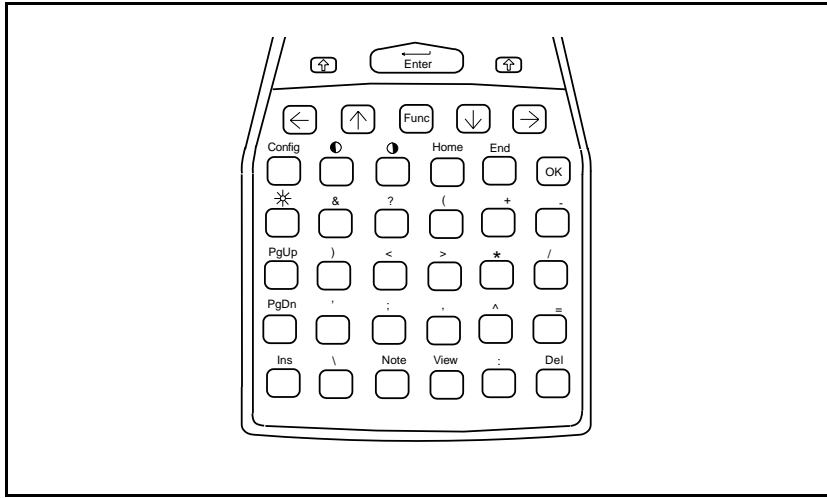

Figure 2-2 TDC2 Function Key Sequences

2.9 Screen

The TDC2 has a large LCD screen, which the Asset Surveyor software configures to display eight lines of 40 characters each. The screen is protected by a tough polycarbonate window. Like glass, it can be scratched, so care should be taken to protect it.

The LCD works by variations in contrast, rather than by emitting its own light, so it remains extremely readable no matter how bright the background light may be. If the screen becomes dirty, wipe it with a clean cloth. Do not use solvents or abrasives as these might damage the screen. Do not leave the screen in bright sunlight for long periods, particularly inside a vehicle.

2.9.1 Backlight

In low light, you can use the built-in backlight to increase visibility. To turn on the backlight, press **[Func] [E]**. To turn the backlight off, press **[Func] [E]** again. The backlight places an additional drain on the TDC2's battery (and that of the GPS receiver, if the TDC2 is being powered from the receiver's battery), so it should only be used when necessary

2.9.2 Contrast

To adjust the LCD for maximum clarity, hold the TDC2 at the angle on which you will be working, then repeatedly press the **[Func]** key followed by the **[A]** key (which reduces the LCD contrast) or the **[Func]** key followed by the **[B]** key (which increases the LCD contrast) until the TDC2's display appears clearest.

2.10 Operating System

The TDC2's operating system is MS-DOS version 3.30, and is stored in ROM. It is possible for you to run other MS-DOS application programs on the TDC2. If you want to write or customize your own application programs for the TDC2, you are referred to the Husky FS/2 System Developer's Guide, which you can obtain from:

Husky Computers Ltd,
Eden Road,
Walsgrave Triangle Business Park,
Coventry CV2 2TB
United Kingdom
Telephone: +44 (1203) 604 040

To access MS-DOS, you must exit from the Asset Surveyor program. Do this by pressing the **(Esc)** softkey on the Asset Surveyor software's main menu. To return to the Asset Surveyor program from MS-DOS, you can either reboot the TDC2. For more information see Rebooting the TDC2, page 2-3, or you can run the program ASSET.EXE on the TDC2's D: drive.

2.11 Barcode Wand

The optional Hewlett Packard HBCR-8300 barcode wand can read codes backwards (i.e. right-to-left) or forwards (i.e. left-to-right). Be careful not to drop the barcode wand or scratch the glass tip. When packing it in the carrying case, position it so the cord is not crimped and the glass tip is not touching a hard surface.

You can plug in the barcode wand to the TDC2's 'COM1' port (the left-hand port, when looking at the front of the TDC2) and use it whenever you wish, unless you are already using the 'COM1' port to communicate with an ESP sensor or laser rangefinder.



Note – You must turn the TDC2 on and let Asset Surveyor run for a few seconds before plugging the barcode wand into 'COM1'. If you plug the barcode wand into 'COM1' before turning the TDC2 on, the barcode wand will not work.



Note – You can only use the barcode wand for swiping attribute values in the TDC2's 'COM1' port. It will not work if plugged into the 'COM2' port (except perhaps if used as an external sensor for swiping other types of barcodes).

The barcode wand is capable of decoding a number of common barcode formats:

- Interleaved 2 of 5
- UPC/EAN/JAN
- Codabar
- Code 128
- Code 11
- MSI code
- Code 3 of 9

This last format (which is also referred to as ‘Code 39’) is the format that the Trimble Pathfinder Office software uses to print barcodes.

2.12 Servicing the TDC2

For replacement parts, service information, hardware operating questions, or repair, contact Trimble Navigation Limited at the address and telephone number listed in the Warranty section of the *GPS Mapping Systems General Reference* manual.

3 Installing the Asset Surveyor Software

When you receive a TDC2 from Trimble, the datalogger will already have the Asset Surveyor software loaded into its memory. You will only have to install the Asset Surveyor software onto your TDC2 under one of the following conditions:

- You have received or purchased an upgrade to your existing Asset Surveyor software.
- Your TDC2 was stored for an extended period without batteries, and/or its EEPROM was erased or corrupted.
- You used your TDC2 for some other purpose (for example, to run some software which you had purchased or written yourself), and had to delete the Asset Surveyor software from the TDC2 to make room.

3.1 Equipment Required for Upgrading

In order to upgrade the software in the TDC2, you will require the following equipment:

- A Trimble Office Support Module (OSM-PF or OSM). An OSM or OSM-PF is supplied with most Trimble GPS systems of which the TDC2 is a component. You will require an adaptor cable to connect the OSM to your TDC2.



Note – If you do not have an OSM or OSM-PF, you **cannot** upgrade the software in your TDC2.

- An IBM-compatible PC with at least one serial RS232 port and at least one high density (1.44 MB) 3½" disk drive.
- Optionally, a 9-pin to 25-pin converter. This is required if your PC has a 25-pin serial port connector on its COM1: port.
- Your TDC2 datalogger.
- The distribution disk for the TDC2 software product to which you want to upgrade your TDC2.



Caution – It is **crucial** that you have all of the equipment listed above before you commence upgrading. **Do not attempt to substitute other equipment.** By using the recommended equipment and following the instructions provided later in this chapter, you should be able to quickly and reliably upgrade your TDC2 software. If you use inappropriate equipment or fail to follow the upgrading instructions, it is likely that you will be unable to upgrade your TDC2 successfully. There is even a possibility that the current software in your TDC2 may be erased without being updated, in which case you would have to return your TDC2 to Trimble for servicing.

3.2 Upgrading the Asset Surveyor Software on your TDC2

The following instructions enable you to upgrade a TDC2 which already has the Asset Surveyor software installed to a new version of the Asset Surveyor software, or to another Trimble TDC2 software product.

To upgrade the Asset Surveyor software:

1. Connect the equipment listed on page 3-2 as shown in Figure 3-1.

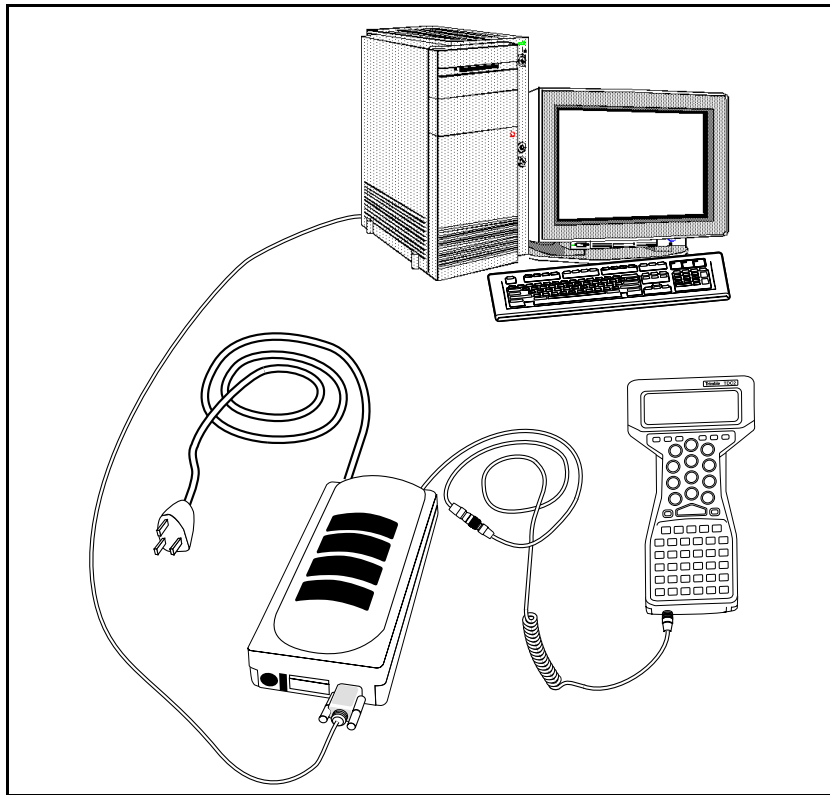
**Figure 3-1 Cabling for Asset Surveyor Installation**

Plug the OSM into the wall current (mains). Connect the OSM to the bottom of the TDC2 (using an adapter cable, part number 27996). Connect the OSM to the PC's COM1 serial port. Turn on the TDC2, OSM and PC if they are not already on.



Caution – You **cannot** perform the installation while connected to your PC's COM2 port.

Presuming that you have all of the necessary equipment arranged as described above, proceed as follows:

2. On the TDC2, go to the Asset Surveyor's *Main menu*:

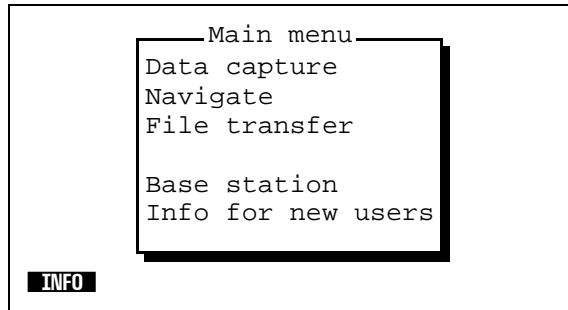

3. Select *Main Menu / Utilities*:

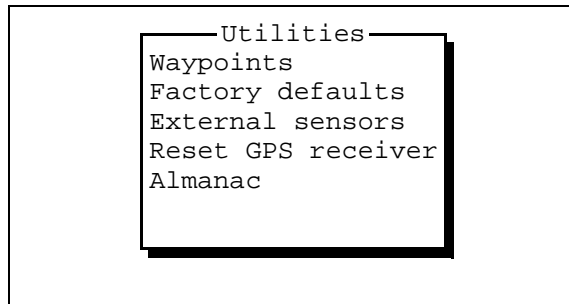

4. Select *Utilities / Upgrade software*:

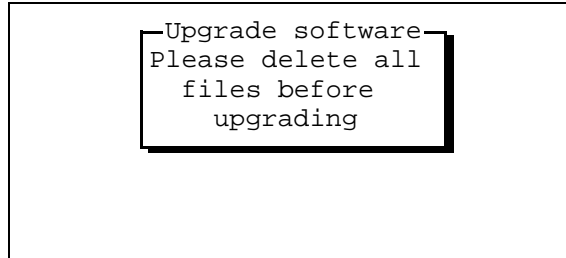

Asset Surveyor will completely erase the contents of the TDC2's memory when the TDC2's software is upgraded, so it will refuse to upgrade until you have output and deleted all data files from the TDC2.

Once you have transferred any remaining data files to your PC and deleted them from the TDC2, repeat steps 2 and 3 above before continuing.



Tip – You may also want to transfer waypoints from your TDC2 to Pathfinder Office before upgrading, since the waypoint file on the TDC2 will also be erased by the upgrade procedure.

Once Asset Surveyor has checked that all data files have been deleted, it asks you to finally confirm that you want to proceed with the upgrading of the TDC2's software:

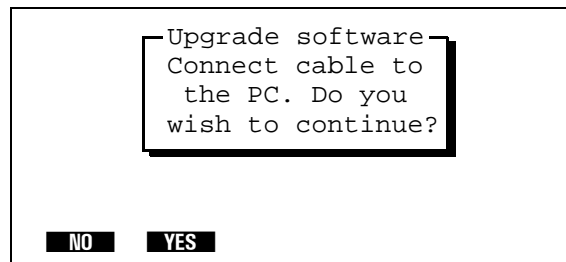

5. Press **YES** to continue with the upgrade procedure.

At this point Asset Surveyor ensures that the TDC2 is receiving external power. You cannot upgrade your Asset Surveyor version unless external power is available. This avoids the possibility of your TDC2's batteries going dead during the upgrade process and leaving your TDC2's Flash EEPROM (non-volatile memory) in an unpredictable state.

If Asset Surveyor cannot detect external power, it displays the following message:

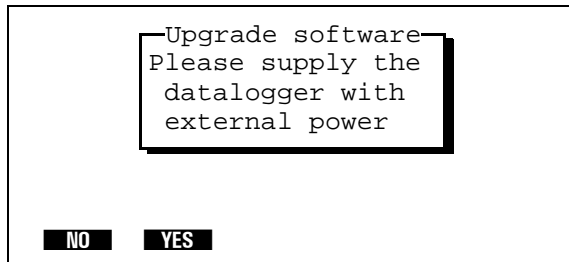

If you have forgotten to connect a cable or turn on the OSM, do so now and press **YES** to continue. If it appears that your equipment is connected correctly and turned on, press **NO**. You should check that your equipment is correct, and then disconnect and reconnect each cable firmly before repeating steps 1 to 5. If the TDC2 still cannot detect external power, contact your Trimble Assistance Center.

Once the TDC2 is receiving external power, Asset Surveyor will display the following message:

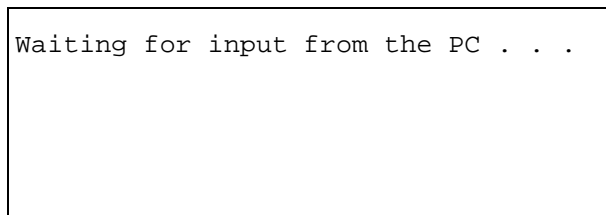

From this point onwards, the first phase of the upgrade procedure is controlled from the PC. You should not have to touch the TDC2 keypad again until this phase is completed and the second phase has begun. If you do press (Esc) at this point, the upgrade procedure will be aborted and no harm will have been done. Forcibly stopping the upgrade procedure at a later stage (by disconnecting cables or power, or by pressing (Esc)) may have unpredictable effects.

6. Now turn to your PC.

Insert the distribution disk for the product to which you want to upgrade into the PC's 3½" disk drive and log to that drive (i.e. if the disk is in drive A: then type **A:** at the DOS prompt; if the disk is in drive B: then type **B:**, etc.).



Note – You *must* run the upgrade procedure from the disk drive; you *cannot* copy the contents of the upgrade disk onto your hard drive and run it from there.

7. When logged to the drive containing the distribution disk, type the following command on the PC:

UPGRADE [ENTER]

The TDC2 upgrade program which is provided on the distribution disk will start to run. You will see the following message appear on your PC:

```

                U p g r a d e
          Copyright (c) Trimble Navigation Ltd, 1995.

Phase 1
-----
Completed successfully
Phase 2
-----
Please check the TDC2's screen and follow any instructions which
may appear there.
```

The second phase of the upgrade procedure involves the erasing and rewriting of the TDC2's Flash EEPROM. Once this has been completed, you will see the following display on the TDC2's screen:

```
Input Directory : C:\FLASH
Output Selection: Flash Drive
```

The lower part of the TDC2's screen will display messages indicating which components of the Asset Surveyor software are being written to the TDC2's Flash EEPROM at each stage.

When the TDC2's Flash EEPROM has been completely erased and rewritten, the following message will be displayed on its screen:

8. Press any key to restart the TDC2. The newly upgraded software will begin to run.



Tip – If you have just upgraded to a new version of the Asset Surveyor software, you will now have to reload any data dictionaries, coordinate system files, language files, and waypoints, as these will have been erased when the TDC2 was cold-booted. You will also have to re-configure the Asset Surveyor software if you had altered any of the settings under the *Configuration* menu in the previous Asset Surveyor version.

You should always retain any TDC2 software distribution disks you receive from Trimble, as you may need to reload or upgrade your TDC2 using those distribution disks.

4 Basics of Operation

This chapter introduces you to the Asset Surveyor software, its user interface, and data entry concepts.

4.1 Starting and Stopping the Asset Surveyor Software

You generally do not have to stop the Asset Surveyor software, as you can just turn off the TDC2 when you have finished using it and turn it on again when you next want to use it.

4.1.1 Starting the Asset Surveyor Software

When you turn the TDC2 on (by pressing **[Ⓟ]**), the Asset Surveyor software normally continues running where it left off. However, if, when you turn the TDC2 on, the Asset Surveyor software is *not* running, you can start it from the DOS prompt by typing **D:ASSET** and pressing **[Enter]**, or by rebooting the TDC2. For more information see Rebooting the TDC2, page 2-3. (To type a ‘:’ character when in DOS, press the **[⇧]** and **[Z]** keys simultaneously).

4.1.2 Stopping the Asset Surveyor Software

You can stop the Asset Surveyor software by exiting to the *Main menu* and pressing the **[Esc]** key once more. Typically, however, you will not need to stop the Asset Surveyor software; you can just turn the TDC2 off (using **[Ⓟ]**) and turn it on again when you next wish to use it.



Note – You cannot turn the TDC2 off while Asset Surveyor is logging data to a file, or while transferring files between the TDC2 and the PC.

4.2 The Asset Surveyor Menu Structure

The Asset Surveyor *Main menu* entries are shown in Figure 4-1.

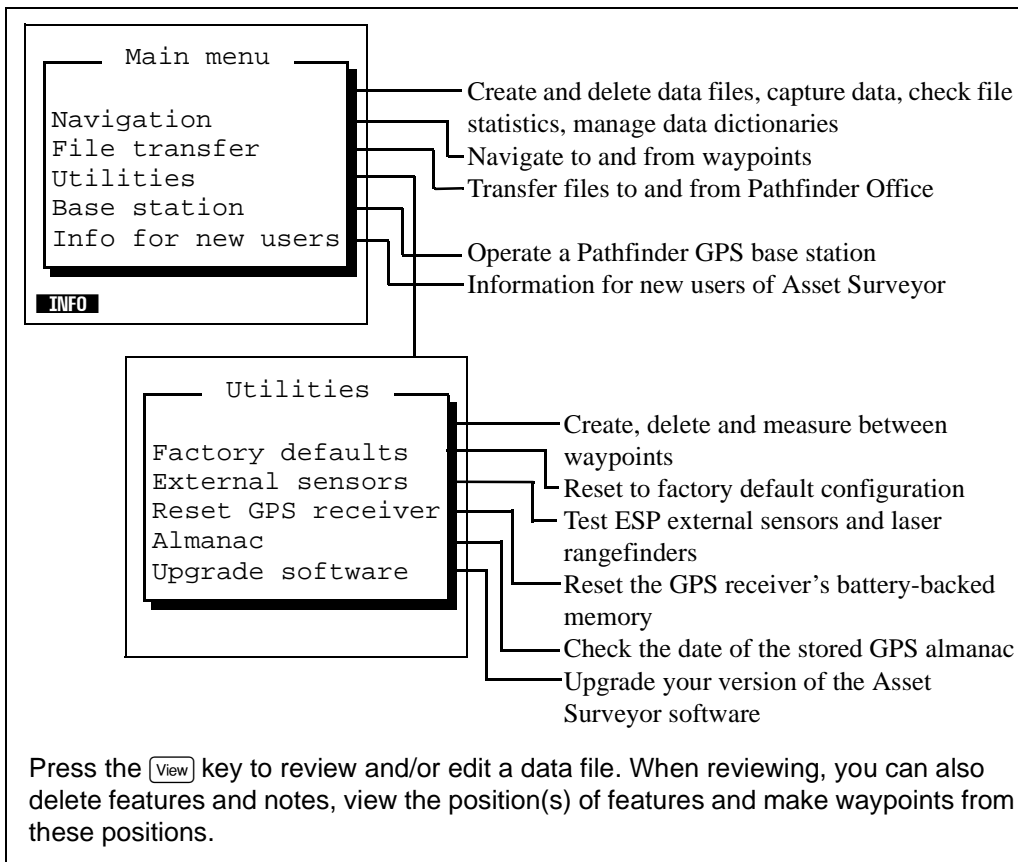

Figure 4-1 Asset Surveyor Main Menu

Asset Surveyor's *GPS operations* menu appears when you press the **GPS** key.

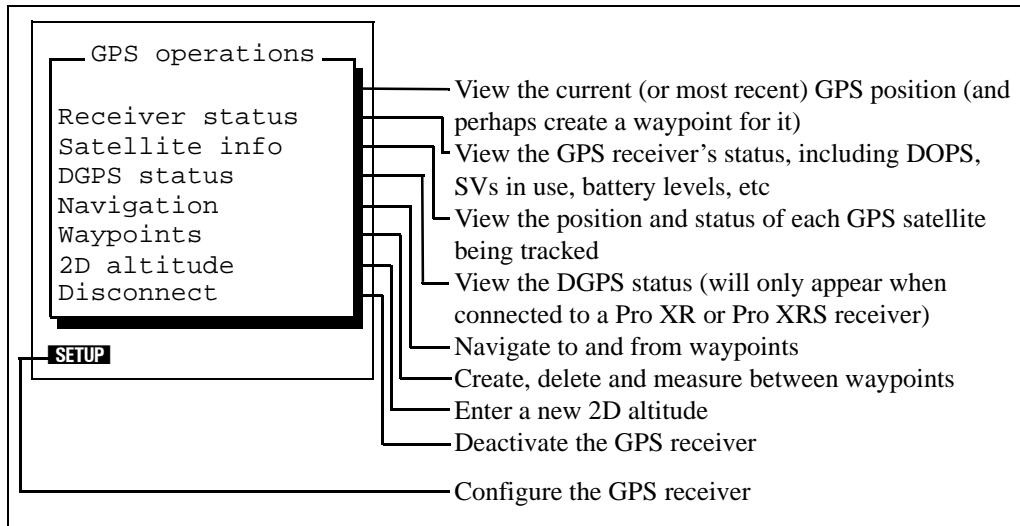

Figure 4-2 Asset Surveyor GPS Operations Menu

Asset Surveyor's *Configuration* menu appears when you press the **Func** **GPS** key.

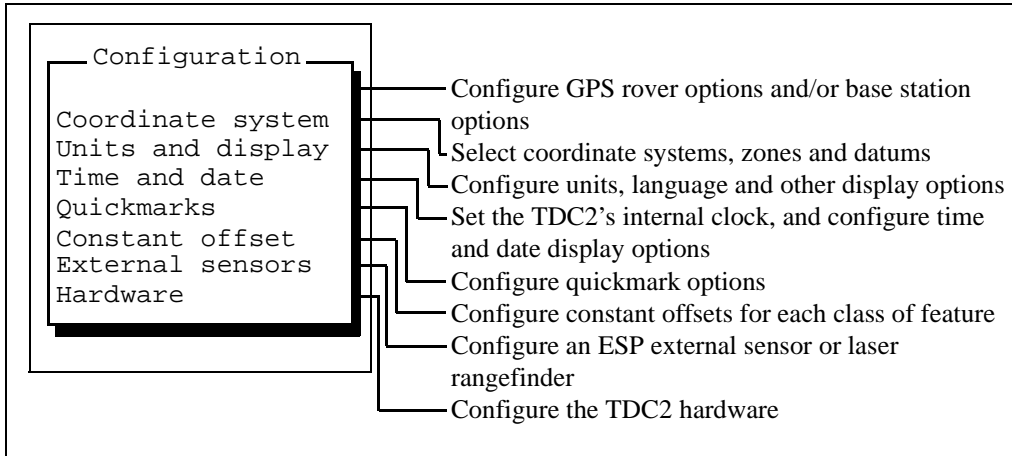

Figure 4-3 Asset Surveyor Configuration Menu

4.3 User Interface Components



You can interact with the Asset Surveyor software in a variety of ways, each of which is described below:

4.3.1 Hard Keys



These are the physical keys on the TDC2's keypad, and include alphabetic and numeric keys as well as special-purpose keys such as

, , etc.

4.3.2 Softkeys

When the TDC2 is on, the bottom line of the screen shows a number of *softkeys*, so-called because they vary depending on context. Each of these softkeys corresponds to one of the (hard) *function* keys, numbered  to . Pressing the corresponding function key activates the function indicated by the softkey label. For example, on the following screen:



pressing  activates the *Pause* function, pressing  activates the *Repeat* function, etc.

Occasionally, there are too many softkeys on a particular form or menu to fit onto the TDC2's screen. When this happens, the fifth softkey appears as **→**. You can press **→** to step from one 'page' of softkeys to the next. Press the softkey you require when its 'page' appears. When there are less than five softkeys, the remaining function key(s) perform no action.

4.3.3 Pop-up Messages

Occasionally, messages will 'pop up' on the TDC2's screen. For example:

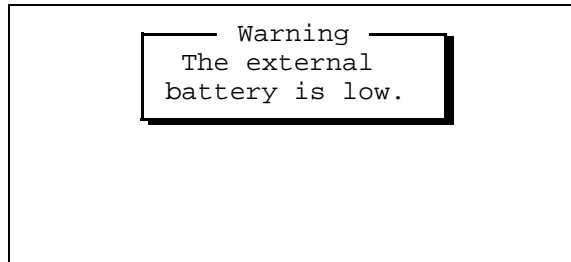

Messages with a 'Warning' or 'Error!' title should be noted and can then be dismissed from the screen by pressing **Esc**. Other messages will automatically disappear after four seconds, but can also be dismissed manually by pressing **Esc**.

When Asset Surveyor is performing a lengthy task (anything longer than about two seconds), it will pop up a message. For example:

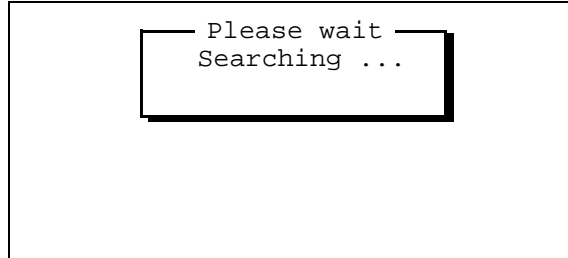

When this message appears, you should wait until Asset Surveyor has completed the task and removed the message itself. If you do not wish to wait for Asset Surveyor to complete the task, you can abort the task by pressing (Esc). There are a few critical tasks which cannot be aborted. If Asset Surveyor is performing a critical task and you press (Esc) to abort it, Asset Surveyor will simply beep and continue with the task.

4.3.4 Pop-up Menus

When there is a choice of actions or answers to a question, Asset Surveyor pops up a menu, showing you the possible choices, and allowing you to pick one of them. For example:

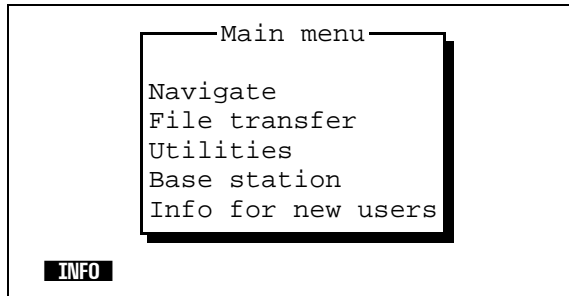

A menu has a current entry, which is highlighted (e.g. `<u>N</u>avigate`). You can choose a different entry from the menu by moving the highlight to your preferred entry and selecting it. You can move the highlight in a number of ways:

- The `<u>↑</u>` and `<u>↓</u>` keys move the highlight up or down the menu a single entry at a time.

If you have positioned the highlight on the first (i.e. top) entry in the menu, and then press `<u>↑</u>`, the highlight will move to the last (i.e. bottom) entry in the menu. This is a convenient way to travel quickly to the bottom of the menu, and lets you browse through a menu circularly. Similarly, if you have positioned the highlight on the last entry in the menu, and then press `<u>↓</u>`, the highlight will move to the first entry in the menu.

- The `<u>PgUp</u>` and `<u>PgDn</u>` keys move the highlight up or down a page at a time. The length of a page is normally four entries when GPS is connected and five entries without GPS.

The **[PgUp]** and **[PgDn]** keys do not behave circularly. Once you are less than a page from the top of the menu, pressing **[PgUp]** again will just take you to the first entry in the menu. Pressing it yet again will have no effect. Similarly, once you are less than a page from the bottom of the menu, pressing **[PgDn]** again will just move the highlight to the last entry in the menu. Pressing it yet again will have no effect.

- The **[Home]** and **[End]** keys move the highlight to the first and last entries in the menu, respectively.
- Pressing an alphanumeric key corresponding to the first letter of a menu entry will move the highlight directly to that entry. If there is more than one entry in the menu starting with that letter, pressing that alphanumeric key repeatedly will step through the entries beginning with that letter.

Once your chosen menu entry has been highlighted, you can *select* it by pressing **[Enter]**. If you highlight a menu entry by typing the first letter of its name, and it is the only entry in the menu which starts with that letter, the entry will be selected automatically.



Tip – This ‘first-letter’ method is often the fastest way of selecting an entry from a menu.

If a menu has more entries than will fit onto the TDC2 screen at one time, the entries in the menu will scroll up and down within the visible pop-up menu. The fact that there are entries which you cannot currently see is indicated by the presence of ↑ and/or ↓ characters on the right-hand border of the menu. For example, the following screen is a menu which has further entries below those which can be currently seen.

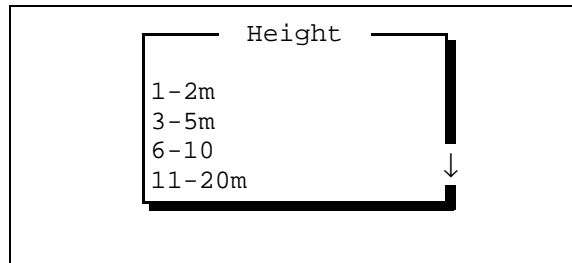

The following screen shows a menu which has entries both above and below those which can be currently seen.

4.3.5 Questions

Whenever Asset Surveyor asks you a question, it will pop up a message and two softkeys for you to press in response. An example of a question is:

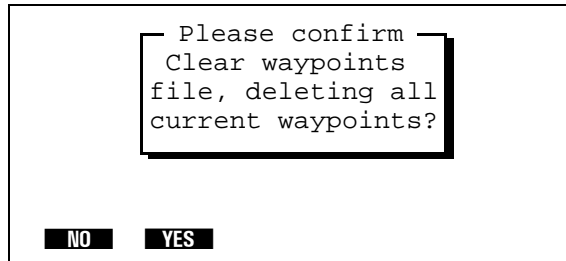

You can answer 'Yes' to a question in a number of ways:

- By pressing **YES**
- By pressing **Y**.

Similarly, you can answer 'No' in a number of ways:

- By pressing **NO**
- By pressing **N**
- By pressing **Esc**.

4.3.6 Forms

Data entry in the Asset Surveyor software takes place in “forms”. These are like paper forms, in that they are made up of a title and a sequence of lines or fields. An example of a small Asset Surveyor form is the following:

Tree	
Variety:	Pine
Height:	
Girth:	?
Date:	09/03/93 Fri
Additional comments:	Needs to be ...

Fields

Each field generally has two parts, a prompt (or name) and a value. Each field's prompt is usually followed by a colon (:), to clearly separate it from the field's value. Some fields are *separator* fields, which have no value and serve simply to divide a form into sections.

The example form shown above has a title (“Tree”) and five other fields, each with a prompt (on the left) and a value (on the right).

One field of every form is the current field, and is distinguished by being highlighted. Any editing operations on a form apply to the current field. If the field's value can be edited, then the value is highlighted. Otherwise, the field's prompt is highlighted. In the example above, the current field is the second field, with the *Height* prompt.

If a field's value cannot be shown in its entirety, due to the limited width of the TDC2 screen, ellipses (‘...’) are used to indicate that part of the field's value is not currently visible. For example, the full value of the *Additional comments* field in the example above is Needs to be pruned.



Note – There is a special field value, called the **null** value, which denotes no value at all. This is often supplied as the default value for a field, to **force** you to enter a real value. The null value is usually displayed as a ‘?’ character, but Asset Surveyor lets you configure the null value if you wish.

Windows

The contents of an Asset Surveyor form are displayed in a *window* on the TDC2 screen. Windows are separated by horizontal lines drawn across the screen.

Windows vary in size, and often a form will have too many fields (lines) to fit entirely in its window. When this happens, you can scroll the fields in the form up and down, by moving the highlight, in order to see the other fields on the form.

If a form contains too many fields to fit on the TDC2 screen at one time, a ‘↓’ character will appear on the right-hand-side of the form’s title line, as shown in the following example:







Title line		↓
Field 1:		Value 1
Field 2:		
Field 3:		Value 3
Field 4:		Value 4
Field 5:		Value 5
Field 6:		Value 6
Field etc:		Value etc

Moving Between Fields

A form's current field is distinguished by having its prompt or value highlighted. If the field can be edited, then the value is highlighted, but if the field is purely informative, and cannot be edited, then the prompt is highlighted instead.

You can move the highlight from field to field using the keys shown in Table 4-1.

Table 4-1 Movement Keys

Key	Description
	Moves the highlight up one field.
	Moves the highlight down one field.
	Moves the highlight up one page.
	Moves the highlight down one page.
	Moves the highlight to the first field in the form.
	Moves the highlight to the last field in the form.

A page of a form is the same size as the form's window. This means that you can see every field in a form by paging through it pressing  repeatedly.

Some forms are divided into sections, where each section starts with a caption field. Typically, the prompts for the fields following a caption are indented slightly, as shown in the following example:

File start	
	10:44:12 am
Date:	09/14/93 Tue
File end	
Time:	06:23:05 pm
Date:	09/15/93 Wed

where the two sections of the form follow the *File start* and *File end* captions.

As previously mentioned, all editing operations in a form apply to the current (highlighted) field, so you will want to move the highlight from field to field both to scroll the contents of the form within its window, and also to position the highlight on a field ready to edit that field's value. You can edit fields in any order.

A caption field can never become the current field, and can never be edited (as it has no value).

Leaving a Form

When you have finished browsing through a form, or have finished editing a form's fields, you can choose to leave it with or without saving its (edited) contents.

To leave a form without saving its contents press **Esc**. If the value of any of the form's fields has changed (i.e. been edited), Asset Surveyor will ask you the following question:

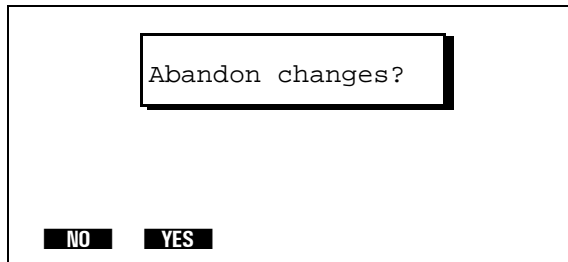

The image shows a dialog box with a white background and a black border. Inside the dialog box, the text "Abandon changes?" is centered. Below the text, there are two buttons: "NO" on the left and "YES" on the right. Both buttons have a black background and white text.

If you press y, any changes which you have made to the form's fields will be discarded. If you press n, you will be returned to the form.

You can leave a form and save its contents by pressing **OK**. When you do this, Asset Surveyor will validate the form, checking each field for consistency and completeness and then save the form's new contents.

Editing Fields

In general, each field's value can be changed or edited. Before you can change the value of a particular field, you must move the highlight to that field.



There are two ways of changing the value of the current (highlighted) field:



- Type the complete new value into the field. Once you have highlighted the appropriate field's value, you can just type in the new value. This will replace the field's old value.
- Edit the field's existing value. You indicate that you wish to edit the current field's value by arrowing into it using (which starts editing at the left-hand end of the original value) or (which starts editing at the right-hand end of the original value).

Once you have started to enter a new value for a field, or to edit the existing one, the appearance of the field will change, and a flashing cursor will appear. For example, if you moved the highlight to the *Height* field of the example *Tree* form and pressed to start editing the existing value of that field, the TDC2 screen would look as follows:



Tree		
Variety:		Pine
Height:	3	
Girth:		?
Date:	09/14/93	Tue
Additional comments:	Needs to be ...	
SV 4/6 PDOP 2.4 # 23		

Each character you type will be inserted into the field at the location of the cursor, and the cursor will move one position to the right, ready for the next character to be typed.



You can move the cursor about within the field using  and .



You can delete the character which is ‘under’ the cursor (e.g. the 3 in 3 . 4 in the example above) by pressing . You can delete the character to the left of the cursor, and move the cursor one character to the left in the process, by pressing .

Insert and Overwrite Modes

The Asset Surveyor software usually operates in Insert mode, where each character you type is inserted at the cursor position and pushes the current character in that position to the right, after which the cursor moves one position to the right as well. You can put Asset Surveyor into Overwrite mode by pressing . In Overwrite mode, each character you type overwrites the current character at that position, after which the cursor moves one position to the right. Pressing  again will put Asset Surveyor back into Insert mode.

Upper and Lower Case Letters

Press  to change between upper and lower case letters, remembering to press  again to change back.

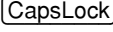
The TDC2 differs from regular PC's in that  changes modes, rather than just modifying characters typed while it is held down. The  key therefore operates like the  key on a PC.

Leaving a Field

If you start to edit a field and decide that you would rather not proceed, press **Esc** to revert back to the field's previous value and to abandon the editing of that field.

When you have changed the field's value to your satisfaction, you can:

- Press **↑** to move to the previous field in the form.
- Press **↓** or **Enter** to move to the next field in the form.
- Press **OK** to validate and save the entire form.

Before moving to another field, Asset Surveyor will validate the new value for the field which you have just changed. If the field's new value is inappropriate, you will be informed of this fact and asked to change it. The Asset Surveyor software will **not** accept an inappropriate value for a field.

Certain fields behave in special ways when being edited, and have special validation rules, as explained in the following section.

Field Types

Each field belongs to a particular type or class, and the type of the field determines the kind of value it can have. The types of field supported by the Asset Surveyor software are:

- Captions or separators, which you cannot edit and have no value.
- Alphanumeric character string fields, which allow the entry of any characters (i.e. letters, digits and punctuation characters), up to a certain maximum length. An example of an alphanumeric string is the comment `Needs to be pruned`.
- Numeric fields, that let you enter numbers, with or without attached units. An example of a numeric value is `'3.4'`.
- Menu fields, that let you select one of a small set of specific values. For example, a menu field might let you choose between values of Yes, No and Maybe.
- Date fields, which allow the entry of a calendar date. An example of a date value is `09/03/93 Fri`.
- Time fields, which allow the entry of a time of day. An example of a time value is `10:44:12 am`.

The following sections discuss each of the Asset Surveyor field types in more detail.

Alphanumeric Fields

An alphanumeric field will accept values made up of almost any character you can type (and a few you cannot). Such a field could be used for storing a street address, a person's name, or a description of a fault in a piece of equipment.

When you are entering a value into an alphanumeric field, Asset Surveyor will make a **SYMB** softkey available. Pressing this softkey will cause a menu of special punctuation symbols to pop up, e.g.

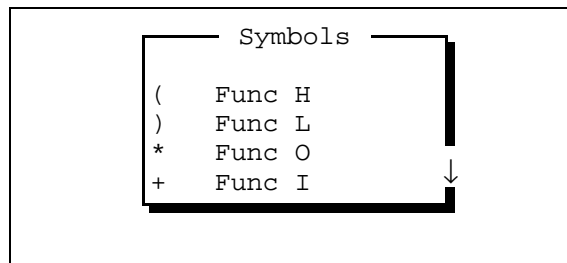

If you select an entry from this menu, the special character will be inserted into the alphanumeric field which you were editing, at the current cursor position. If you decide not to insert a special character after all, press **Esc** to dismiss the menu.

The pop-up menu of special symbols will highlight the entry that you last selected, for convenient reselection.



Note – The *Symbols* menu also indicates which special characters can be typed directly using a **Func** key sequence.

Numeric Fields

Numeric fields store and display numeric values in a range of formats, separated into two main classes:

- For integer (i.e. non-fractional) numeric fields, Asset Surveyor lets you enter digits only and a '-' sign. An integer field could be used to store the number of wheels on a vehicle, or the number of ducks on a pond. Examples of integer numeric values are:

4, 123, -987, 0

- For non-integer numeric fields, Asset Surveyor lets you type digits only, a '-' sign, a decimal point ('.'), and the 'E' (or 'e') convention for scientific notation. A non-integer field could be used to store a bank account balance, or the length of a vehicle. Examples of non-integer numeric values are:

1.4, 0.005, -1.23, 1.2E10, 5.678e-3



Note – The notation employing 'E' (or 'e') to represent a power of 10 is called exponential or scientific notation, and is used to enter very large or very small values. For example, a value such as 12000000000.0

could either be entered as

'12000000000.0'

or, as

'1.2e10'.

Because scientific notation is very compact, it tends to be used by engineers and scientists, who often have to deal with very large and very small numbers.

Many non-integer numeric values represent a measurement of a physical phenomenon and have associated units. Such values belong to physical domains such as distance, speed, time, etc. Asset Surveyor knows about each of the base domains, and can convert values from one unit to another within a domain.

If a non-integer numeric data field has an associated units domain, Asset Surveyor will prohibit the entry of values or units which are inappropriate for that domain. Each field displays its contents in a specific unit or sequence of units, but you can enter values in the most convenient unit, provided you use a unit appropriate for the domain of the field. For example, you can type a value into an *Antenna height* field in meters, feet or inches, but not in °C or kilograms. If the *Antenna height* field's display units are meters, then values entered in feet or inches will be converted to meters and displayed that way once they have been validated.

The Asset Surveyor software lets you configure the units used for most numeric fields to suit your application or preference, as described in Chapter 5, Configuring the Asset Surveyor Software.

Some examples of numeric fields with units are as follows:

- If a field represents a distance, and Asset Surveyor has been configured to display distances in meters, entry of the values:

54.5,

54.5 m,

0.0545 km,

0.0339029 mi,

178.82 ft, or

2145.84 in

would all yield the final value 54.5 m in the field.



Note – You do not have to specify units if the field's display units are the same as the units of the value you enter into that field. In the above example, entering '54.5' was the same as entering '54.5 m'.

- If a field represents an angle, and Asset Surveyor has been configured to display angles in degrees, minutes and seconds, entry of the values
20.332777778,
20.332777778°,
20 19 58, or
0.354873918299 rad

would all yield the final value 20°19'58" in the field.



Note – Some numeric values can be displayed using more than one unit (e.g. degrees, minutes and seconds for angular values). You can enter values using a sequence of units (e.g. 20°19'58"), or you can just separate values with spaces (e.g. 20 19 58), in which case Asset Surveyor applies each display unit in sequence to successive values.

- The location of a geographic entity on the earth's surface can be specified as a latitude and a longitude. Asset Surveyor will display latitudes and longitudes in degrees, minutes and seconds, so you can enter the location of Trimble's headquarters in Sunnyvale, California, by typing the following values into appropriate latitude and longitude fields:
37°23'40.09" N
122°02'16.77" W

where the 'N' and 'W' denote latitude North of the equator and longitude West of the Greenwich meridian. When entering a latitude or longitude, the letters N, S, E, W (for North, South, East or West) may be entered before or after the actual latitude or longitude value.



Note – ‘+’ or ‘-’ signs may be used instead of the letters N, S, E or W, where positive latitude is North of the equator and positive longitude is East of Greenwich. The sign may be entered before or after the value.



Tip – If you enter a position as a latitude and longitude, and do not explicitly specify the hemisphere, the Asset Surveyor will presume that you intend the position to be in the hemisphere in which you are currently operating, as determined by your most recent GPS position.

To assist with the entry of units, Asset Surveyor provides a **UNITS** softkey whenever you are entering a value into a numeric field which has units. Pressing this softkey causes a menu of available units to pop up, from which you can select the unit(s) you wish to attach to the value you are entering.

For example, if you press the **UNITS** softkey when entering a *Distance* value, the pop-up menu of available units will appear as follows:

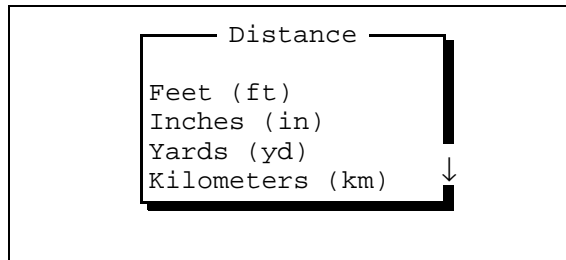

You can select a suitable unit for the *Distance* value you are entering from this list.



Note – The list of available units indicates the abbreviation for each unit in parentheses (). You can enter the abbreviation for a unit directly using the keypad, if you prefer.

The TDC2 keypad does not appear to allow the entry of some of the special characters required for specifying units (for example °, ', and so forth). However, Figure 2-2, on page 2-10, shows how characters can be typed using **[Func]** key sequences. Usually, numeric fields will be displayed in the appropriate units so that you need not specify units explicitly, or you can use the **UNITS** softkey.

Menu Fields

The Asset Surveyor software uses pop-up menus to provide you with a choice between a number of alternatives. Sometimes, fields in a form can also take one of a number of discrete values, and Asset Surveyor also uses a pop-up menu to let you choose a value for such a field.





In our example form, the first field (the tree's *Variety*) could be a menu field:

Tree	
Variety	☐
Height:	3.4
Girth:	?
Date:	09/14/93 Tue
Additional comments:	Needs to be ...
SV 4/6 PDOP 2.4 # 23	



Note – A menu field is indicated by a menu symbol (☐) in place of the colon, when that field is highlighted.

There are a number of ways of selecting a new value for a menu field:

- Pop up the menu and select a value, as described for normal Asset Surveyor pop-up menus. You can pop up the menu for a menu field by positioning the highlight on that field and pressing .
- Select a value immediately by typing its first letter. This is a very quick way to select a value for a menu, once you know the possible values for that menu field. If the key you press does not correspond to the first letter of any entry in the menu, the menu will pop up so that you can see the list of possible values and then select one. Similarly, if the key you press corresponds to the first letter of more than one entry in the menu, the menu will pop up and let you see the various choices.
- Step forward through the values in the menu using the  key and backward through the values in the menu using the  key. Using this method, the menu is circular, so that if you reach the first element in the menu and press , you will step to the last element in the menu. Similarly, if you reach the last element in the menu and press , you will step to the first element.

The latter two methods of selecting values for menu fields are provided for the convenience of experienced Asset Surveyor users. You will probably begin by popping up each menu and selecting from the displayed list of values, but as time goes by you will start to use these shortcuts to make selecting values for menu fields even faster.

Date Fields

A date field can be used to record any calendar date since the Gregorian calendar came into being (on Friday the 15th of October, 1582). Dates prior to this cannot be entered, as the Asset Surveyor software does not support the previous (Julian) calendar.

Different countries use different conventions for the entry and display of calendar dates. The Asset Surveyor software can be configured to display dates in

- MM/DD/YYYY,
- DD/MM/YYYY, and
- YYYY/MM/DD

formats, where MM represents the month, DD the day, and YYYY the year. For example, in MM/DD/YYYY format, the 4th of July 1976 would be displayed as:

07/04/1976

Note that if the year is entered as two digits it is presumed to be in the current century as determined by the TDC2's internal clock. Thus, 76 is interpreted as 1976. If you wish to enter a date from a different century, type the year in full.

When you are entering a value into a date field, Asset Surveyor makes two softkeys available to assist you, e.g.

Tree	
Variety:	Pine
Height:	3.4
Girth:	?
Date:	0
Additional comments:	Needs to be ...
SV 4/6 PDOP 2.4 # 23	
 / 	TODAY

Because the ‘/’ character is a little inconvenient to type on the TDC2 keypad, Asset Surveyor makes a **■/■** softkey available. You can also type the **Func P** sequence on the TDC2 keypad to obtain the ‘/’ character.



Note – The Asset Surveyor software also accepts dates entered with spaces between the components, e.g. ‘7 4 76’, but will always format and display dates itself with the ‘/’ character as a separator.

The **TODAY** softkey can be pressed to fill in the field with the current date (as determined from the TDC2’s internal clock). Many Asset Surveyor date fields are filled in with the current date automatically, and you only need to enter the date manually if this automatic date is incorrect.

Asset Surveyor automatically works out the day of the week from the date that you have entered, and displays it as a means of checking that you have entered the correct date.

Time Fields

A time field is used to store the time of day, and may either be filled in automatically from the TDC2’s clock, or entered manually.



Note – A time field is not used for storing *elapsed* time (e.g. the amount of time taken for an athlete to complete a race); this is better represented as a numeric field.

Hours, minutes and seconds are delimited by a colon (‘:’) character. Times are displayed using either 12- or 24-hour clock format. In the 24-hour clock format, ‘4:30pm’ is displayed as ‘16:30’. Asset Surveyor allows the entry of time in either format. If the entered time is less than ‘12:00’ and ‘p.m.’ is not specified then ‘a.m.’ is assumed. The Asset Surveyor software can be configured to display times in either format.

When you are entering a value into a time field, Asset Surveyor makes four softkeys available to assist you:

- Because the ‘:’ character is inconvenient to type on the TDC2 keypad Asset Surveyor makes a **⏏** softkey available. You can also type the **Func Z** sequence on the TDC2 keypad to obtain the ‘:’ character.



Note – The Asset Surveyor software also accepts times entered with spaces between the components, e.g. ‘4 30 00’, but will always format and display times itself with the ‘:’ character as a separator. Neither minutes nor seconds need be entered, but if minutes are desired then hours must be present, and if seconds are desired then both hours and minutes are required. For example, 10 o’clock in the evening could be entered as ‘10pm’, ‘22’, ‘10:00pm’, ‘22:00’, ‘10:00:00pm’, ‘22:00:00’, or ‘10:0:0pm’.

- You can press the **⏏** softkey to fill in the field with the current time (as determined from the TDC2’s internal clock, which will be precisely aligned to UTC time if a GPS receiver is currently connected). Many Asset Surveyor time fields are filled in with the current time automatically, and you only need to enter the time manually if this automatic time is incorrect.
- You can press the **⏏** softkey to insert the character sequence ‘am’ into the field. This is generally unnecessary, as Asset Surveyor will presume that a time less than 12:00 falls in the morning, in the absence of any explicit ‘pm’ indication.
- You can press the **⏏** softkey to insert the character sequence ‘pm’ into the field. This is necessary if you wish to enter a time after noon in 12-hour format.

4.3.7 Barcodes

You can use a barcode wand to enter GIS attribute data. You must use Trimble's Pathfinder Office software to print a list of barcodes corresponding to a particular data dictionary. These barcodes can then be used for entry of menu field values whenever you are capturing data to a file which uses that data dictionary. When the barcode for a particular menu value is swiped, the new value for that menu field is decoded from the barcode.

Attribute entry and data dictionaries are described in more detail in Chapter 7, The Main Menu.

4.4 File Naming Conventions

The Asset Surveyor software is designed primarily for the capture of GIS and GPS data and the storage of this data in files on the TDC2. These files can be individually named, but because you may need to capture a vast quantity of data which is all very similar in nature, it can be difficult to think of meaningful yet distinct names for data files. Asset Surveyor automatically suggests a name for each new data file when it is created.

For the purposes of automatic naming, Asset Surveyor data files are divided into two classes, called rover and base station files. Most data files will be rover files. The Asset Surveyor software lets you capture GIS feature and attribute information to rover files, along with GPS positions, etc. Asset Surveyor also lets you use your Trimble GPS receiver as a GPS base station, which results in the creation and recording of base station files. Operating an Asset Surveyor base station is described in detail in Chapter 7, The Main Menu.

When a rover data file is created, Asset Surveyor suggests a default file name according to the following formula:

R MM DD HH x

where the initial letter 'R' identifies the data file as being a rover file, MM is the current month, DD is the current day of the month, and HH is the current hour of the day. The final letter 'x' will increment within this hour, starting at 'a' for the first file in that hour, then going to 'b' for the second file and 'c' for the third file, etc.



Note – The date and time used for naming of data files is, by default, UTC (GMT) time. You can specify that Asset Surveyor should use local time to name rover files by pressing the **TIME** softkey and selecting *Local* from the pop-up menu. If the default file name looks odd, check that the TDC2's internal time and date are set correctly.



Tip – The initial letter ‘R’ can be changed, in which case subsequent rover data files will be given the new initial letter. This lets you uniquely name data files from a fleet of Asset Surveyor rovers, using initial letters like ‘X’, ‘Y’, ‘Z’. To change the initial letter of a file name to ‘X’, simply type ‘X’ and then press  to move on to the next field in the form. Asset Surveyor will automatically regenerate the default file name with an ‘X’ prefix.

Some examples of default rover file names for the morning of the 15th of September are:

R091510a,
R091510b, and
R091511a.

Remember that the default file name suggested by Asset Surveyor is simply a suggestion. You can change the suggested name or enter an entirely different name. You can use such file names as:

SURVEY1,
SC0090, and
RONALD

if you wish. File names can be at most eight characters long, and are composed of letters and digits only (i.e. no spaces or punctuation characters are permitted).

Trimble suggests, however, that unless you will be dealing with a small number of data files at a time, you should consider using the automatic file names, as these assist with identifying files by time and date.

Asset Surveyor suggests default names for base files which are formatted slightly differently from those suggested for rover files. They follow the formula:

B Y MM DD HH

where the initial letter 'B' identifies the file as being a base station file, Y is the last digit of the current year, MM is the current month, DD is the current day of the month and HH is the current hour of day. This is the format used by Trimble's Pathfinder Community Base Station™ software.



Note – As with rover files, the default base file name can be constructed using either local or UTC (GMT) time, the default being UTC. Press the **TIME** softkey to select which time system you wish to be used for base station file names.



Tip – As with default rover file names, the initial character 'B' of a default base file name can be changed, in which case subsequent base data files will be given the new initial character. This lets you conveniently name data files from a number of base stations separately, e.g. Bases A to C could use the initial letters 'A', 'B' and 'C'.

Some examples of default base file names for the morning of the 25th of January 1995 are:

B5012510

B5012511

B5012512.

As with rover files, you can edit the suggested file name or replace it entirely, but Trimble suggests that you use the default names for base files so that they will be consistent with base files from other Trimble products, and because the time and date of a base file is crucial to its use for differentially correcting rover files.



Note – You can configure Trimble’s Universal Reference Station™ (URS) software to use either local time or UTC (GMT) time to construct base file names. Trimble’s Pathfinder Community Base Station™ software uses UTC time when constructing base file names. When matching base and rover files for differential correction, it is important to be aware of the naming conventions and time scales used by these software systems.

4.5 Software and Firmware Version Numbers

You can determine the version of the Asset Surveyor software you are currently using in two ways:

- Turn your TDC2 off and on again. When it is turned on it will briefly display a screen showing the Trimble logo, a copyright message, and the software version number.
- Select the *Hardware (TDC2)* option from the *Configuration* menu. Scroll to the third page, where the only item is *Software ver.* This shows the current Asset Surveyor software version.

If you ever need to call Trimble Navigation Limited with questions about the Asset Surveyor software, you should first determine the software version you are currently running, using the above procedure.

You can also determine which firmware version is installed in your GPS receiver, as described in Chapter 6, GPS Operations Menu (in the *GPS Receiver status* form).

5 Configuring the Asset Surveyor Software

This chapter describes the *Configuration* menu. Page headings throughout the chapter provide a convenient summary of the menu structure described on the page.

There are a number of critical aspects of Asset Surveyor's operation which must be configured before you proceed to capture data. There are also a large number of non-critical configuration options which you can set to suit your application or your preferences. This chapter describes in detail each option that you can configure in the Asset Surveyor software.

Although you should certainly check the Asset Surveyor configuration before embarking on a survey, you can (re)configure Asset Surveyor at any point, while it is being used. Press **Config** to pop up Asset Surveyor's *Configuration* menu, from which you can select the aspect(s) of the system you wish to check or change. The *Configuration* menu has the following entries:

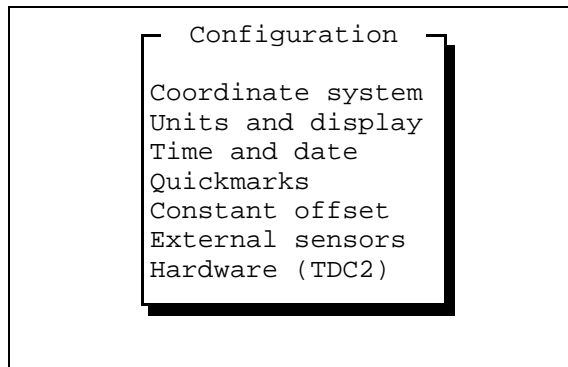

Configuration/ GPS

When you select the *GPS* entry from Asset Surveyor's *Configuration* menu, you will usually have to choose between configuring aspects of a GPS rover or a GPS base station.

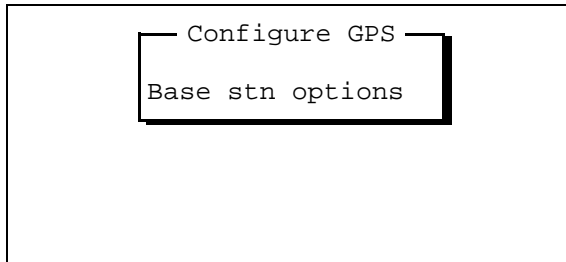

However, if you are connected to a Trimble GPS receiver and it is already operating as a rover or as a GPS base station, Asset Surveyor will anticipate which GPS options you wish to configure, and take you directly to either the *GPS Rover options* configuration form or to the *GPS Base stn options* configuration form.



Note – The Asset Surveyor software cannot act as a base station for a Series 4000 GPS receiver. If you select the *GPS* entry from the *Configuration* menu when connected to a Series 4000 receiver, you will proceed directly to the *Rover options* configuration form.



Note – If you are using the Asset Surveyor software and a Trimble GPS receiver to navigate with, use the *GPS Rover options* to configure the GPS receiver.

Configuration/ GPS/ Rover Options

If you select *Rover options* from the *Configure GPS* menu, or if you select the *GPS* entry from the *Configuration* menu when a rover data file is open, then the following configuration form appears:

Rover options	
Logging intervals	
Point feature:	5s
Line/area:	5s
Not in feature:	None
Velocity:	None
Minimum posns:	3
Carrier phase	
Minimum time:	10mins
Pos mode:	Manual 3D
Elev. mask:	15°
SNR mask:	6.0
PDOP mask:	6.0
PDOP switch:	6.0
Audible click:	Yes
Log DOP data:	Yes
Dynamics code:	Land
Initial position	
Lat:	?
Lon:	?
<input type="checkbox"/> RTCM	<input type="checkbox"/> ANTEN
<input type="checkbox"/> P(Y)	<input type="checkbox"/> OUTPUT

This entire form will not fit onto the TDC2's screen at once, so you should scroll through it to select the specific rover option(s) you wish to change.

The form above shows the default values for each rover option that you can configure. These will be the values configured in Asset Surveyor when you run it for the first time. You do not need to change any of these settings in order to test your Trimble GPS equipment, but you may want to change some of the options before setting out to capture data.



Note – The **P(Y)** softkey will not appear if you are currently connected to a GPS receiver which does not support P(Y) mode.

The following sections describe each configurable rover option in detail.

Configuration/ GPS/Rover Options/ Logging Intervals

The *Logging intervals* heading refers to the following four configuration options, which specify intervals (periods of time) between the logging of various types of information, in varying circumstances.

- *Point feature.* The interval between logged GPS positions when you are capturing a point feature. The default logging interval for point features is five seconds. This means that when you start a point feature, Asset Surveyor will log GPS positions once every five seconds, until you end the feature.
- *Line / area.* The interval between logged GPS positions when you are capturing a line or area feature. The default logging interval for line and area features is five seconds. This means that when you start a line or area feature, Asset Surveyor will log positions once every five seconds, until you end the feature. Asset Surveyor will also log a GPS position immediately after starting the feature and just before ending it.
- *Not in feature.* Although most of the GPS data which you log will probably be associated with a feature (i.e. a point, line or area), you can use Asset Surveyor to log GPS positions *between* features, so that your final data file contains a trail showing where you went during the survey. By default, Asset Surveyor will not log positions unless in a feature, so the logging interval when *Not in feature* has the default value None.



Note – Carrier phase data for points, lines and areas will be logged in addition to code-phase positions if you have configured the *Carrier mode* to 'On' in the *Create file* form (See page 7-3 in Chapter Seven, The Main Menu). If the configured interval is greater than 30 seconds, the logging interval will be rounded to the nearest interval that is a factor of ten, and carrier phase will be logged every ten seconds. If the logging interval is a multiple of 30 seconds, then carrier phase will be logged every 30 seconds. This will only occur when logging carrier phase. If you are logging only code-phase positions, no rounding will take place.

- *Velocity*. You can request Asset Surveyor to log your velocity at regular intervals by setting the *Velocity* option to a value other than None (the default).

Velocities might be logged in order to map and analyze traffic flow, or to show that you performed a survey at a constant velocity (e.g. when required to traverse a region at a certain optimal speed in order to conduct other experiments).

Recent enhancements to the Pathfinder Office processing software enable the differential correction of velocities logged from Pathfinder GPS receivers. Corrected velocities can be used by Pathfinder Office to slightly increase the accuracy of differentially corrected positions.



Note – Velocities logged from Series 4000 receivers cannot currently be differentially corrected.



Note – You can change the logging intervals at any time, even when you are already logging a feature.



Tip – When you are editing an interval field, Asset Surveyor makes two softkeys, **ALL** and **NONE**, available. Press **ALL** to specify that you want every available GPS position to be logged. Press **NONE** to indicate that you want no positions to be logged.

The position logging interval you specify has an impact on the accuracy of differentially corrected positions. Ideally, the position logging interval at the roving receiver should be identical to, or an exact multiple of, the measurement logging interval at the base station. This enables precisely synchronized differential corrections to be computed. If rover logging of positions is not synchronized with base station logging of measurements then interpolated differential corrections must be computed, with an associated loss of accuracy.



Warning – If you are recording carrier phase data in addition to code-phase positions, you **must** configure this interval to be synchronized with the measurement logging interval at the base station. There is no interpolation of carrier phase measurements.

Configuration/ GPS/Rover Options/ Minimum Positions

In order to obtain the best GPS accuracy for a point feature, you should remain at that feature for some time, logging a number of GPS positions. If these positions are subsequently differentially corrected and averaged, the average position will be better than a single GPS position. With a Pro XL, Pro XR or Pro XRS system, you can obtain submeter accuracy with a single position.



Note – For up-to-date information on recommended occupation times, refer to the most recent documentation or release notes associated with your specific Trimble GPS receiver.



Note – When operating Asset Surveyor in carrier mode, the *Minimum posns* will not apply.

When Asset Surveyor has logged the specified minimum number of positions for a point feature, it will beep to let you know that you have logged sufficient positions to achieve your required accuracy. If you attempt to save a point feature before the minimum number of positions have been logged, Asset Surveyor will warn you:

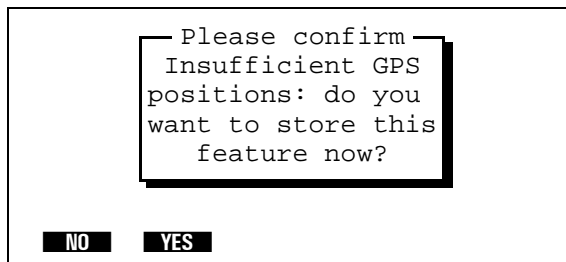

You can choose to store the feature anyway, accepting a possible loss of accuracy, or you can remain inside the feature until more positions have been logged.

In general, you will log positions for line and area features until you have traveled the length of the line or the perimeter of the area. There is no minimum number of positions for these feature types.

Configure/ GPS/Rover Options/ Carrier Phase

In order to obtain the best carrier phase precision, you should collect enough carrier phase information for the Differential Correction Utility in Pathfinder Office to compute high accuracy positions. Generally, the longer the block of continuous carrier data, the greater the precision of the features that are captured within it.



Note – If you are connected to a receiver that does not support the logging of carrier phase data, this option will not appear.

Asset Surveyor lets you set the minimum amount of time that you wish to collect carrier phase information. There are five available options ranging from five to 45 minutes.

Features captured within a block of carrier data that exceeds the time set in the *Minimum time* field will achieve a level of precision relative to this time.



Note – Trimble suggests you switch your *Position mode* setting to 'Overdetermined 3D' when capturing carrier phase data.

At the logging interval specified, the status line will display a message similar to that shown below, informing you of the current amount of carrier phase data collected since the last break in the carrier phase data. This time will correspond to the time shown in the *Carrier time* field in the *Receiver status* form.

26:00 Carrier Time

When Asset Surveyor has logged carrier phase data continuously for the time specified in the *Minimum time* field, it will sound the success beep to let you know that you have logged sufficient carrier phase data. The following message will also appear on the status line to inform you that the *Minimum time* has been reached:

Min. time achieved!

If the *Carrier time* in the *Receiver status* form resets before the *Minimum time* has been exceeded, the following message will display:

Carrier lost 26:30



Note – You can use the review file function in Asset Surveyor to check the features that may not achieve the desired precision.

In addition, Asset Surveyor will also write a note to the data file informing you of the time when the *Carrier time* was reset, and the amount of carrier phase information collected for that block since the previous loss of carrier lock. You can review this note in the field, or back in the office using the timeline in Pathfinder Office.

```
Review note
Carrier lock lost
Carrier time 26:15
09:16:20 am
```

When the GPS receiver successfully re-acquires complete carrier phase information, the following message will appear on the status line to inform you that the carrier time has restarted.

```
Carrier started
```

If you attempt to close a file before the *Minimum time* has been exceeded, and you have logged a position during that time, Asset Surveyor will prompt you to confirm that you do want to close the file:

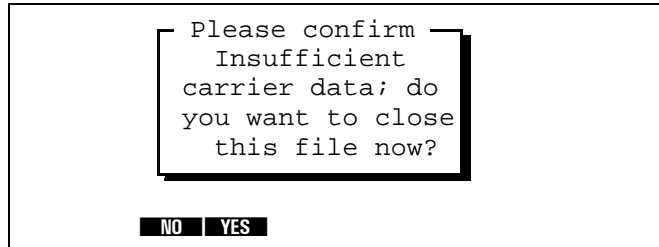

You can choose to close the file anyway, accepting a possible loss of accuracy, or you can keep the file open until more carrier phase data has been logged.

Configuration/ GPS/Rover Options/ Position Mode

The position mode in which your Trimble GPS receiver will operate is configured by selecting one of the four values *Manual 3D*, *Auto 2D/3D*, *Manual 2D* or *Overdet. 3D* from the *Pos mode* menu. This mode will fundamentally affect the operation of your GPS receiver, and should only be modified after you have fully understood the consequences, as described below:

- *Manual 3D*. In Manual 3D mode, which is the default, your Trimble GPS receiver will use as many satellites as it is capable of using (but at least 4) to compute positions. This will usually yield the most accurate GPS positions and is the most flexible mode in which the receiver can be operated. If your GPS receiver is capable of computing overdetermined GPS positions, it will do so in Manual 3D mode when there are more than four satellites available.

You should always use Manual 3D mode or forced Overdetermined 3D mode in order to achieve a high level of accuracy for logged positions.

Auto 2D/3D. In Auto 2D/3D mode, your Trimble GPS receiver will use four satellites to compute GPS positions when it is able to, but when the number of visible satellites falls to three, it will continue to compute positions, using the last known altitude. A position computed when there are only three usable satellites is called a two-dimensional position, and the accuracy of two dimensional positions is crucially affected by the accuracy of the altitude.

In Auto 2D/3D mode, when the GPS receiver switches to 2D mode (i.e. when there are only three usable satellites), it will use the altitude of the last available 3D position, or any altitude which you have entered manually since the last 3D position was computed. You can manually enter a 2D altitude by popping up the *GPS operations* menu and selecting *2D altitude*.

If you are operating in conditions where satellite visibility is poor and you are able to determine your altitude above the WGS-84 ellipsoid very accurately at all times, then you may wish to try Auto 2D/3D mode. However there is a high probability that your data will not always be very accurate due to altitude input errors.



Caution – If you use *Auto 2D/3D* mode and specify an inaccurate altitude, this will have a **significant** impact on the position computed by your GPS receiver. As a rule of thumb, every meter of error in the altitude you supply is likely to cause **at least** three meters of error in the position computed by your GPS receiver.



Note – The Pro XR, Pro XRS, and Series 4000 GPS receivers support *overdetermined 2D mode*, meaning that they can use **four or more** satellites to compute a 2D solution. When the *Pos mode* is set to *Auto 2D/3D*, this will occur in circumstances when the 3D PDOP exceeds the configured *PDOP mask*, but the overdetermined 2D PDOP is below the *PDOP mask*.

- *Manual 2D*. In Manual 2D mode, a Pathfinder GPS receiver will *always* use the best three satellites available, even if there are four or more which could be used for computing positions. You must supply an accurate altitude above the WGS-84 ellipsoid before using Manual 2D mode. This mode is useful if you are absolutely sure of your altitude above the WGS-84 ellipsoid, as it avoids the inaccuracies experienced in Auto 2D/3D mode when the GPS receiver switches from using a 3D altitude obtained from GPS to using the 2D altitude which you supply. Unless you are operating exclusively at the same altitude, you **must** manually enter a new altitude whenever you move up or down.



Caution – If you use Manual 2D mode and specify an inaccurate altitude, this will have a **significant** impact on the position computed by your GPS receiver. As a rule of thumb, every meter of error in the altitude you supply is likely to cause **at least** three meters of error in the position computed by your GPS receiver.



Note – The Pro XR, Pro XRS and Series 4000 GPS receivers support **overdetermined 2D mode**, meaning that they can use **four or more** satellites to compute a 2D solution. When the *Pos mode* is set to *Manual 2D*, these receivers will use as many satellites as it can to compute an overdetermined 2D position.

- *Overdet. 3D.* In Overdetermined 3D mode, your Trimble GPS receiver will use as many satellites as it is capable of using to compute positions. These GPS positions will only be logged if there are at least five satellites available, so that all logged positions are forced to be overdetermined. This yields the most accurate GPS positions.

Configuration/ GPS/Rover Options/ Elevation Mask

You can restrict your Trimble GPS receiver to using only those satellites above a certain elevation in the sky by imposing an *Elevation mask*. The default elevation masks recommended by Trimble are 15° for rovers and 10° for base stations. This difference ensures that a base station can always ‘see’ all of the satellites which can be seen by any rovers. If you choose to alter the rover elevation mask, be very careful to ensure that your base station (if any) still has a lower mask, to ensure that you can still differentially correct data files collected by that rover. These days there is rarely a need to use an elevation mask lower than 15°, given the number of GPS satellites in service, but if you do decide to lower your elevation mask(s), you should be aware that the increased ionospheric noise associated with satellites low on the horizon can easily counter any improvement in PDOP given by a lower elevation mask. Additionally, the effects of multipath increase as lower satellites are used.



Caution – You *must* ensure that the elevation mask for a rover is set higher than the base station, so that the base station always tracks any satellites visible to each rover. Remember that as a rover gets further from the base station, the difference between the elevation mask of the rover and the base becomes more and more critical (due to the curvature of the earth). As a rule of thumb, the difference must be at least 1° for every 100 km between the base and the rover.

Configuration/ GPS/Rover Options/ SNR Mask

The signal strength of a satellite is a measure of the information content of the signal relative to the signal's noise. As this proportion decreases, information gets lost in the noise. The typical signal strength of a satellite at 30° elevation is between 12.0 and 20.0. A value above 20.0 is very good. The quality of a GPS position is degraded if the signal level of one or more satellites in the constellation falls below 6.0.

Asset Surveyor lets you set a mask, called the Signal-to-noise ratio mask (or *SNR mask*), the value of which is used to determine whether the signal strength of each satellite is sufficient for that satellite to be used by the GPS receiver. The default value for Asset Surveyor's *SNR mask* is 6.0.



Note – Trimble's Series 4000 GPS receivers have a fixed internal SNR mask (of 4.0). Asset Surveyor's *SNR mask* configuration variable has no effect on the operation of Series 4000 receivers—it only influences the behavior of Pathfinder GPS receivers.



Caution – If you lower the *SNR mask*, you will permit your GPS receiver to use satellites with weaker signals. While this may increase the GPS coverage you can obtain in environments where the GPS signal is weakened (such as forests), it will probably cause a reduction in GPS accuracy.

Configuration/ GPS/Rover Options/ PDOP Mask and PDOP Switch

The accuracy of a position computed by a GPS receiver is essentially a function of the geometry of the GPS constellation visible at that moment in time. When the visible satellites are well separated in the sky, your GPS receiver is able to compute accurate positions. If two or more satellites are close together in the sky, the small errors inherent in measuring their signals compound, reducing the accuracy of computed positions.

There are several *Dilution of Precision* (DOP) factors associated with GPS, and these DOP factors express an aspect of the expected accuracy of the GPS system. DOP factors are linear multipliers on the expected error, so a small DOP value is better than a large one. The best overall indicator of constellation geometry is known as *Position Dilution of Precision*, or PDOP.

A PDOP value of 4.0 or less tends to give excellent positional accuracy. A PDOP between 4.0 and 8.0 provides acceptable accuracy, while a PDOP of 8.0 or more implies poorer accuracy. When satellites nearly line up in the sky, the PDOP values can briefly go into the hundreds or even thousands, and for those periods computed GPS positions may be quite inaccurate.

Asset Surveyor lets you specify a *PDOP mask*, which the GPS receiver uses as an upper bound on PDOP values. When the PDOP climbs above this mask, the receiver will cease computing GPS positions. This enables you to program a desired level of positional accuracy, and ensure that any positions which you log will be of a certain quality. The default *PDOP mask* value is 6.0.



Caution – Increasing the *PDOP mask* will allow you to log positions for more of the time, but position quality may be seriously degraded. It is better to retain a lower *PDOP mask* and use Trimble’s mission planning software to identify the brief times of high PDOP, and to schedule other activities (like lunch!) in these times, rather than to continue surveying and compromise the accuracy of your survey. Conversely, you should not reduce your *PDOP mask* too far below the value recommended for your particular Trimble GPS receiver, as this will significantly decrease the amount of time you can survey, without significantly increasing the accuracy of your survey.



Note – Some Trimble GPS systems specify a maximum PDOP of 4.0 in order to achieve submeter accuracy. The Pro XR and Pro XRS receivers will achieve submeter accuracy with a PDOP of 6.0 or less.

The *Mapping Systems General Reference* manual provides a more detailed discussion of DOP values.



Note – In 2D mode the *PDOP mask* ought to be set lower than in 3D mode, as two dimensional PDOP values are inherently smaller than PDOP values in three dimensions. Despite this difference, 3D positions will almost always be more accurate than 2D positions due to the difficulty of accurately specifying your 2D altitude above the WGS-84 ellipsoid.

In addition to the *PDOP mask*, Asset Surveyor provides a *PDOP switch* configuration option for users of the *Auto 2D/3D* position mode. Unlike the *PDOP mask*, which determines a cutoff value above which GPS positions will not be computed, the *PDOP switch* is the value at which the receiver will switch from 3D to 2D mode (the *PDOP switch* is therefore effectively a *PDOP mask* for 3D mode, with the *PDOP mask* being applied in 2D mode).

The default values of the *PDOP mask* and *PDOP switch* are the same (6.0), but by altering the value of the *PDOP switch*, you can force your GPS receiver to switch to 2D mode (and deliberately ignore one or more satellites in the process) in order to achieve a lower PDOP-induced error. Of course, your 2D altitude must be very accurately known and entered, otherwise it will induce a greater error in your GPS position than would a higher 3D PDOP.

**Configuration/
GPS/Rover Options/
Audible Click**

By default, Asset Surveyor will cause the TDC2 to click audibly each time a GPS position is logged. This provides assurance that your system is operating normally, without you having to keep a constant eye on the TDC2's screen. If the ticking stops then it is likely that some significant event has occurred (such as a high PDOP value, too few satellites, etc.).

By setting the *Audible click* configurable option to No, you can disable this clicking.

Configuration/ GPS/Rover Options/ Log DOP Data

You can choose to log dilution of precision (DOP) values, so that you have a record of the GPS conditions which prevailed during a survey. These DOP values can be used to provide a degree of quality assurance, especially if you are capturing data and supplying it under contract to a third party, who may require evidence that the data was surveyed carefully and under acceptable GPS conditions.

When the *Log DOP data* configurable option is set to Yes, Asset Surveyor will log values of PDOP, HDOP, VDOP and TDOP (see page 6-17) whenever the PDOP value varies by 0.1 or more, provided the PDOP is below the configured PDOP mask. This provides a good record of each DOP situation which occurred throughout a survey period. The logging of DOP information will increase the size of the data file by up to 10%, depending on the number of constellation changes due to satellites being frequently obstructed (e.g. when driving near trees or buildings).



Note – The Trimble Series 4000 GPS receivers do not provide TDOP information, so the TDOP values logged by Asset Surveyor will always be 0.0 when connected to a Series 4000 receiver.

By default, Asset Surveyor is configured to log DOP values.

Configuration/ GPS/Rover Options/ Dynamics Code

The *Dynamics code* field lets you configure the way in which your GPS receiver will behave by informing it of your usual mode of operation. The *Dynamics code* helps to control the initial acquisition of satellites, the subsequent handling of satellite signal obstructions, and the receiver's behavior in high multipath situations. There are 3 available dynamics codes:

- *Land*. This is the default dynamics code, and is the best for most typical GIS data capture exercises. This mode informs the receiver that you are operating on land, where you may encounter canopy or other obstacles which might obscure satellite signals, and where you will be moving at a relatively low velocity.
- *Sea*. This dynamics code informs the receiver that you are on the water, at a constant altitude, where you might also encounter obstructions but are unlikely to be moving at a very high velocity. The receiver caters for the possibility that its antenna may be mounted on a mast and be moving backwards and forwards reasonably rapidly.
- *Air*. This dynamics code informs the receiver that you are in the air, where you are unlikely to suffer obstruction of satellite signals but where you are likely to be moving at a higher velocity.

These are, of course, general categories into which your application may not necessarily fit. For example, if operating from a balloon, you would be better to choose the *Land* code (which caters for slow velocity, the occasional obstruction, and variations in altitude) than the *Air* code.



Note – If you configure the *Dynamics code* incorrectly, this will generally not cause significant harm. You may notice a slightly degraded initial acquisition of satellite signals, and slightly different behavior when satellite signals are obscured.



Note – The Series 4000 GPS receivers are configured to operate using the *Land* dynamics code at all times. Asset Surveyor's *Dynamics code* field is completely ignored when connected to a Series 4000 receiver.

Configuration/ GPS/Rover Options/ Initial Position

The *Initial position* heading introduces two fields which together specify your approximate position as either a latitude and longitude pair, or as a north and east pair (depending on your selected coordinate system).

When GPS is operating, these fields will be kept up-to-date with the current GPS position. When GPS is not operating, you can consult these fields to see where you were (or more precisely, where your Asset Surveyor system was when it was last used).

The initial position has one important use. Some Trimble GPS receivers have no internal battery-backed memory of their own (to reduce their weight and to save you having to disassemble them periodically to change the battery). These receivers must be sent a GPS almanac when they are powered up, so that they can rapidly acquire signals from satellites and begin to compute GPS positions. Part of a GPS almanac is an approximate initial position, from which the GPS receiver can infer the set of satellites which should be visible at any point in time. With a reasonably accurate (i.e. ± 200 – 300 km) initial position, the startup time of the GPS receiver should be very good (30 seconds to 90 seconds, presuming visibility to satellites). If the initial position is very inaccurate (e.g. the wrong side of the world), startup may take between five and 15 minutes.

If you travel a long way between mapping locations (e.g. you fly from one state to another, or from one country to another), you can ensure a rapid GPS startup by entering an approximate initial position for your new mapping site.



Tip – If you do not know your new mapping site's position, even approximately, you need not worry. Just set up your GPS receiver and start the Asset Surveyor software running. Once your GPS receiver has started to compute positions, its initial position will be updated, and subsequent restarts at or near that location will be rapid again.

Configuration/ GPS/Rover Options/ RTCM Input Options

The **RTCM** softkey on the *Rover options* configuration form leads to the *RTCM input options* form where you can configure the operation of your GPS receiver's RTCM link. An RTCM link is used to receive real-time differential corrections via a radio, modem or other telemetry link. Most Trimble GPS receivers can accept an RTCM input.

The RTCM input options form looks as follows:

RTCM input options	
RTCM input mode:	Auto
RTCM version:	Auto
RTCM station:	Any
Warning time:	20s
Log PP data:	No
Baud rate:	9600
Data bits:	8
Stop bits:	1
Parity:	None
DGPS	

The various fields in this form are described below:

- *RTCM input mode*. Trimble GPS receivers use an incoming RTCM signal in one of three ways, as determined by the *RTCM input mode*. The three modes are:
 - *Off*. When the RTCM input mode is Off, the GPS receiver will ignore the RTCM link completely, even if it is operating correctly. The receiver will compute and emit positions without real-time corrections applied.

- *Auto.* When the RTCM input mode is Auto, the GPS receiver will use the RTCM link when it is operating and emit positions which have been differentially corrected in real time. If the RTCM link is lost (e.g. due to a radio battery failure, or an obstruction of the telemetry link) then the GPS receiver will emit positions which have not had real-time corrections applied. Positions which have not been differentially corrected in real time can be subsequently differentially corrected by postprocessing, providing you have access to a base station which is logging data for post processing.
- *On.* When the RTCM input mode is On, the GPS receiver will only compute and emit positions when the RTCM link is operating. All positions which it emits will have been differentially corrected in real time. None of the data which is logged will require postprocessing.

Asset Surveyor's default value for the RTCM input mode is Auto, as this mode provides the greatest flexibility. If you require all logged positions to be corrected in real time, then you should set the mode to On. If you want to temporarily disable real-time corrections, without having to physically disconnect your radio, you should set the RTCM input mode to Off.



Tip – If your RTCM link appears to be functioning correctly, but Asset Surveyor indicates that RTCM is not being used, check that you have not inadvertently set the RTCM input mode set to *Off*.

- *RTCM version.* There are currently two main RTCM protocol versions in use, called RTCM Version 1 and RTCM Version 2. There is also a sub-version of RTCM used by the U.S. Coast Guard. Most Trimble GPS receivers support the newer RTCM Version 2 protocol. Some Trimble GPS receivers support only Version 1 of the RTCM protocol, while some receivers support both main RTCM versions. The Trimble Series 4000 receivers are capable of supporting all three of these RTCM versions, which can be purchased as receiver firmware options. You should set the *RTCM version* field appropriately for the RTCM signal which you plan to use. If you are unsure which RTCM version is being transmitted by your base station, try setting the *RTCM version* to Auto (the default). If you set the *RTCM version* to Auto when connected to a Series 4000 receiver, Asset Surveyor will configure the receiver to expect RTCM Version 2. If you set the RTCM version to one of the USCG formats when connected to a Pathfinder GPS receiver, Asset Surveyor will configure the receiver's RTCM version to Auto.



Tip – If your RTCM link appears to be functioning correctly, but your GPS receiver indicates that RTCM is not being used, check that you have selected the appropriate *RTCM version*. If you are unsure as to which version of RTCM your radio/modem is receiving, select *Auto*.

- *RTCM station.* Typically, there will only be one GPS base station broadcasting RTCM differential corrections at a particular frequency in the area where you operate. Occasionally, however, there will be more than one base station available, particularly as you move from one area to another. By default, your Trimble GPS receiver will attempt to choose the 'best' RTCM base station (based typically on the distance to the base station). You can, however, indicate that you wish to use a particular GPS base station by entering its *station ID* into the *RTCM station* field. If you enter any value other than the default (Any), Asset Surveyor will instruct your GPS receiver to accept differential corrections only from the indicated base station. You should leave the *RTCM station* field set to Any unless you specifically require this functionality.



Tip – If your RTCM link appears to be functioning correctly, but Asset Surveyor indicates that RTCM is not being used, check that you either have the *RTCM station* set to *Any*, or you have entered the correct *RTCM station ID* for the GPS base station which you wish to use.

- *Warning time.* Most RTCM telemetry links broadcast RTCM corrections every few seconds. The more frequently you receive RTCM corrections, the more accurate your real-time corrected data will be. If a single correction is missed (e.g. due to a temporary telemetry glitch, or due to you passing behind some obstruction), your GPS receiver will continue to apply a projection of the most recent correction received to each new GPS position which it computes. If the *Warning time* elapses and no new corrections have arrived over the RTCM link, the most recent correction is considered to be too old to provide accurate corrected positions, and the GPS receiver ceases to use it. At that point, you will be warned that your RTCM link has been lost.

You can change the *Warning time* configuration option to suit the expected frequency of RTCM corrections arriving. If your RTCM base station is emitting corrections every five seconds, you may wish to set the warning time to 10 seconds, so that you accept the loss of a single RTCM correction, but will be warned if you miss two in a row.



Note – Some Pathfinder GPS receivers have a built-in RTCM warning time of either 20 or 30 seconds which cannot be changed by Asset Surveyor. The *Warning time* option is only applicable to newer Pathfinder GPS receivers and Series 4000 GPS receivers.

- *Log PP data.* With the Pro XR and Pro XRS receivers, you can elect to log additional data so that GPS positions which were corrected in real-time can be re-processed in the office, provided you have access to a base station which logs data for postprocessing. Postprocessing of RTCM-corrected GPS positions is worthwhile if the real-time base station you are using is a considerable distance from where you are collecting data (and your postprocessing base station is nearer), or if the real-time base station which you are using is inaccurate for other reasons (such as a slow update rate).

Logging of postprocessing data will approximately halve the number of RTCM-corrected GPS positions which you can store in the memory of your datalogger.



Note – The *Log PP data* option will not appear if you are currently connected to a GPS receiver other than the Pathfinder Pro XR or Pro XRS.

- *Baud rate, Data bits, Stop bits, Parity.* The remaining four fields on the RTCM configuration form allow you to specify the serial parameters to be used by your telemetry link. This is necessary for your GPS receiver to understand and decode the RTCM data stream which is being carried over the telemetry link.



Caution – It is very important that you determine the precise serial parameters used by your telemetry link and RTCM base station, and that you accurately enter them into these fields in Asset Surveyor’s RTCM configuration form. Any errors made when specifying these serial parameters can cause the RTCM link to fail.



Note – If you are using the integrated real-time component of the Pro XR or Pro XRS receivers to compute real-time positions, you do not need to alter the serial parameters.

- Pressing the **DGPS** softkey from the *RTCM input options* form leads to the *DGPS Integrated* form where you can configure the operation of the integrated MSK beacon receiver, and the integrated satellite differential receiver.



Note – The **DGPS** softkey will not appear if you are currently connected to a GPS receiver other than the Pathfinder Pro XR or Pathfinder Pro XRS.

Configuration/ GPS/Rover Options/ RTCM Input Options/ Integrated DGPS

The **DGPS** softkey on the RTCM input options form leads to the *Integrated DGPS* form where you can configure the operation of the integrated real-time component of the Pro XR or Pro XRS receiver. The beacon component uses advanced digital-signal processing techniques to track and demodulate signals from DGPS radiobeacons.



Note – This form is not used for the configuration of an RTCM link via a radio, modem or other telemetry link. This operation is configured using the *RTCM input options* form

When configured to operate the integrated MSK beacon component of the receiver, the *Integrated DGPS* form looks as follows:

Integrated DGPS	
Source:	Beacon
Mode:	Auto range
Frequency:	N/A
1	
2	
0	
0	

The fields in this form are described below:

- *Source*. The Pro XRS receiver lets you choose whether to utilize either the beacon component or the DGPS satellite component of the receiver, or to turn the integrated DGPS components off. If you are using the Pro XR receiver, you will only be able to select Beacon or Off.

- *Mode*. The Beacon receiver component of the Pro XR and Pro XRS receivers tracks radiobeacon signals in one of three ways, as determined by the *Mode*. The three modes are:
 - *Auto range*. When the *Mode* is set to Auto range, the Pro XR and Pro XRS will automatically track and lock onto the nearest differential radiobeacon signal. If a differential radiobeacon becomes unreliable (i.e. Out of range), the receiver will automatically begin searching for the nearest radiobeacon signal, and if one is available, will continue to maintain continuous DGPS coverage. This is the default and recommended control mode.
 - *Auto power*. When the *Mode* is set to Auto power, the Pro XR and Pro XRS will automatically track and lock onto the differential radiobeacon signal that is detected as being the most powerful. If a differential radiobeacon becomes unreliable (i.e. becomes too weak), the receiver will automatically begin searching for the most powerful radiobeacon signal, and if one is available, will continue to maintain continuous DGPS coverage.



Warning – If the receiver is tracking more than one beacon signal, it will lock on to the signal that is transmitted by a reference station using an integrity monitor, even if it is further away or has a weaker signal than a signal transmitted by a reference station that is not using an integrity monitor.

- *Manual*. When the *Mode* is set to Manual, the Pro XR and Pro XRS will use only the radiobeacon frequency you specify in the *Frequency* field. If the differential radiobeacon transmitting on this specified frequency becomes unreliable, the warning message ‘RTCM Link Lost’ will flash across the status bar. From this point forward, the receiver will compute and store positions without real-time corrections applied, until either the receiver locks onto the specified frequency again, or until a new frequency is specified.
- *Frequency*. This lists the frequency entered that the Pro XR and Pro XRS is to track when in *Manual* mode. When the *Mode* is set to Auto range or Auto power, this field is not editable and will display N/A.

When configured to operate the integrated DGPS satellite component of the receiver, the *Integrated DGPS* form looks as follows:

Integrated DGPS	
Source:	Satellite
Provider:	Omnistar
Satellite:	Optus, Australia
Frequency:	1555.25 MHz
Data rate:	1200
1	
2	

The fields in this form are described below:

- *Source*. The Pro XRS receiver lets you choose whether to utilize either the beacon component or the DGPS satellite component of the receiver, or to turn the integrated DGPS components off. If you are using the Pro XR receiver, you will only be able to select Beacon or Off.

- *Provider.* There are two service providers you can use to receive satellite DGPS signals from. These are Landstar and Omnistar. For more details of these services, refer to the *Pro XR/XRS Receiver Manual*.
- *Satellite.* This lists the DGPS satellites by name that the receiver can track. Select the appropriate satellite for the area you are collecting data within. For more details of each satellite and the area each covers, refer to the *Pro XR/XRS Receiver Manual*.
- *Frequency.* This lists the frequency of the DGPS satellite you specified in the *Satellite* field. If you selected *Custom* from the *Satellite* field list, this field will not be automatically updated.
- *Data rate.* This lists the data rate of the satellite DGPS signal. Some satellites output DGPS signals at a different rate from others, and this field needs to be configured correctly in order to receive the signals. This field will be automatically updated when you select a satellite in the *Satellite* field that has been predefined. If you have selected *Custom* in the *Satellite* field, you may need to configure the *Data rate*.



Note – The *Data rate* field is only applicable to OmniSTAR sourced DGPS satellite corrections. If you specify a LandStar satellite, this field will not appear.

Activating Satellite DGPS

Pressing to accept the *Integrated DGPS* form will begin the activation process to allow you to receive real-time corrections from the LandStar or OmniSTAR DGPS satellite. The time taken for Asset Surveyor to complete the activation may take up to ten minutes. During this time the following message will flash periodically to inform you that Asset Surveyor is waiting for the receiver to be activated;

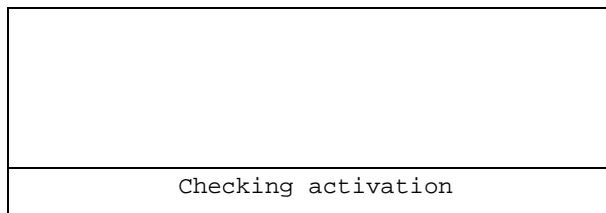

Once the activation has been completed successfully, the following message will display on the status line;

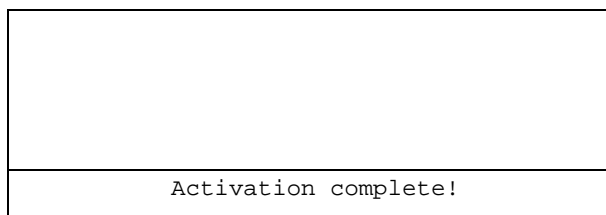

You will need to contact the service provider of your choice (Racal-LandStar or Fugro-OmniSTAR) to activate the satellite DGPS component of the Pro XRS receiver, in order to use this source of real-time corrections. Refer to the *Pro XR/XRS Receiver Manual* for further details to the activation of the Pro XRS receiver.

The GPS Status Line

When RTCM-corrected positions are being emitted by the GPS receiver, Asset Surveyor will indicate this fact by placing an 'R' on the GPS status line, in place of the '#' character. For example:

SV 4/6 PDOP 2.4 R 23

Configuration/ GPS/Rover Options/ Antenna Options

The **ANTENNA** softkey on the *Rover options* and *Base stn options* configuration forms leads to a sub-form where you can configure GPS antenna options.

Typically, you will operate your Trimble GPS system with a GPS antenna on a pole, on a backpack, or mounted on top of a vehicle. If you are interested in capturing the altitude of geographic features, the altitude of the feature will usually be that of the base of the pole, or your feet, or the wheels of your vehicle. In order to accurately record the true altitude of collected features, Asset Surveyor lets you specify the height of the antenna above the point in which you are actually interested. The specified height will be written to the current data file when you commence data capture and whenever you change its value.

For precise location of a feature's altitude, you must specify the height from the point of interest (e.g. the ground) to the electronic center of the antenna (also called the 'Antenna Phase Center' or APC). Because you cannot run a tape measure from the actual center of the antenna, it is usually most convenient to measure to a different part of the antenna and allow Trimble's Differential Correction Utility to apply a correction to the specified height which takes account of the antenna type to yield the true height to the center of the antenna.

A measured antenna height is said to be Vertical if it is the true height from the point of interest to the center of the antenna, or Uncorrected if it is the height from the point of interest to some designated measuring point on the exterior of the antenna.

The *Antenna options* form is as follows:

Antenna options	
Height:	
Measure:	Vertical
Type:	EC
Confirm:	Per feature

where the default values for each field are as shown. These fields are:

- The antenna *Height* is the height from the point of interest (typically on the ground) to the antenna. Whether this is a Vertical or Uncorrected height is determined by the following field. The *Height* field has attached units, which can be altered by changing the *Height* units under *Units and display* (see page 5-74). If you are working in one unit (e.g. meters) and your antenna pole is calibrated in another (e.g. feet), remember that you can enter a value in whatever units you like; this value will then be converted to the units in which you are working. For example, if you entered a height of '2 ft 6 in' when the configured *Height* units are meters, Asset Surveyor will automatically convert '2 ft 6 in' into '0.762 m'.
- The *Measure* field indicates whether the height has been measured to the antenna's center (Vertical) or to a point on the antenna's exterior (Uncorrected).

- The *Type* of the antenna is a two-letter code which identifies each distinct GPS antenna with which the Asset Surveyor software might be used. Specifying the antenna type enables Trimble's Differential Correction software to transform an Uncorrected height to a true Vertical height. Table 5-1 shows which 2-character *Type* code you should enter for your specific GPS receiver's antenna.

Table 5-1 Antenna Type Codes

Antenna	Type	Part #	Measure to ...
Unknown External	E	N/A	N/A
4000ST Internal	I	N/A	Reading from internal tape
4000ST Kinematic (Ext)	EK	14156-00	Bottom of antenna mount
Compact dome	EC	16741-00	Bottom of antenna mount
4000ST L1 Geodetic	EG	14177-00	Bottom of notch
4000ST/SSE L1/L2 Geodetic	E2	14532-00	Bottom of notch on ground plane
4000SE Internal	IE	N/A	Reading from internal tape
4000SSE Kinematic L1/L2	EF	14532-10	Bottom of antenna mount
Compact L1/L2 w Groundplane	G0	22020-00 23158	Bottom of notch on ground plane
Compact L1/L2 Antenna	K0	22020	Bottom of antenna
ProLite	M0	18636-32	Bottom of antenna
Integrated GPS/MSK Beacon	MB	29653-00	Bottom of antenna mount
4600LS Surveyor	IL	28615-20	Read to tape mounting hook

Asset Surveyor maintains two sets of antenna details, one for *Rover options* and one for *Base stn options*, as you will typically set up your GPS system differently if you are planning to operate a GPS base station.



Tip – You only need to measure your antenna height accurately if you wish to record accurate feature altitudes, or if you are using carrier phase mode to fix the position of features to the higher accuracy. Many GIS applications do not even store the altitudes of geographical features.

- The *Confirm* field indicates whether the antenna height form will be displayed prior to commencing each feature (Per feature) or file (Per file). If you do not wish to be prompted for the antenna height, select 'Never'. The default is 'Per feature'.

Configuration/ GPS/Rover Options/ P(Y) Options

The **P(Y)** softkey will only appear when not connected to any GPS receiver (for pre-configuration purposes) or when connected to a receiver with P(Y) capability (e.g. the Trimble Centurion).

A P(Y)-capable receiver uses the GPS P-code (or the Y-code, when the P-code is encrypted) to compute GPS positions. The P- and Y-codes are not susceptible to the effects of Selective Availability (SA). P(Y)-capable receivers are only available to certain approved customers (generally U.S. Federal agencies and specified foreign Governments). Most civilian GPS receivers use the GPS C/A-code, which is subject to the effects of SA. A common synonym for the GPS C/A-code is 'SPS' (for Standard Positioning System), while a synonym for the P(Y)-code is 'PPS' (for Precise Positioning System)

You can press **P(Y)** to pop up the *P(Y) options* form:

P(Y) options	
P(Y) mode	
In feature:	
Not in feature:	On

The *P(Y) mode* can be configured separately when capturing a feature and when not in a feature. Outside data capture, Asset Surveyor will always request P(Y) (i.e. PPS) positions. The P(Y) modes can be reconfigured at any time. The P(Y) modes have the default values indicated above, which imply the following default behavior:

- Within data capture, but outside of a feature, all positions which are displayed and used for navigation will be P-code positions. Any positions logged at the *Not in feature* interval (None, by default) will also be P-code positions.

- Whenever you start a feature, Asset Surveyor will query as to whether or not you wish to use P(Y) mode. You should press **YES** if you are happy with PPS accuracy (10–25 m) and don't want to differentially correct your data, or **NO** if you require the ability to postprocess your data to 1–3 m accuracy. If you always want to capture features either with P-code positions or with C/A-code positions, then you should set the *In feature* P(Y) mode to either On or Off, respectively, to avoid having to answer a question each time you start a feature.

The various P(Y) mode settings are:

- *On*. When the mode is On and the decrypting key is active, Asset Surveyor will request P-code (i.e. PPS) positions. When the decrypting key is inactive, Asset Surveyor will display the following message at startup and when entering data capture:

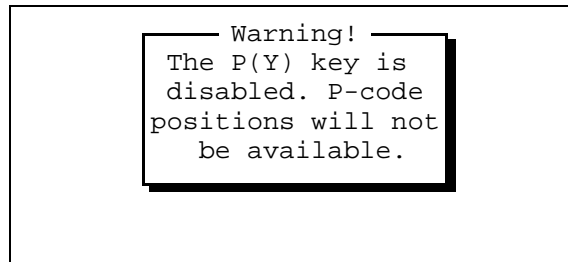

In this case the receiver will emit C/A (i.e. SPS) positions only.

- *Off*. When the mode is Off, Asset Surveyor will request C/A-code (i.e. SPS) positions. These can be differentially corrected via postprocessing.
- *Query*. When the *In feature* P(Y) mode is Query, you will be asked whether or not you wish to use P(Y) mode whenever you start a feature. If the *Not in feature* P(Y) mode is Query, you will be asked whether or not you wish to use P(Y) mode only when you start data capture.

Switching between C/A and P(Y)

It takes several seconds for the receiver to switch between using C/A-code and using P(Y)-code. While switching, Asset Surveyor will display either:

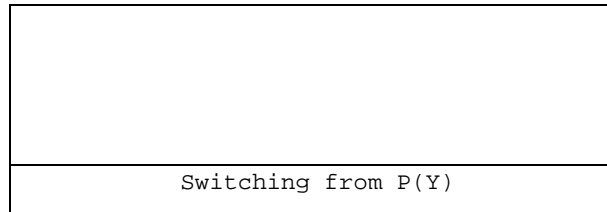

or

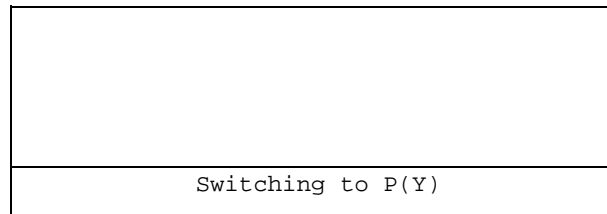

depending on the direction of the switch, on its GPS status line. During this switching phase, GPS positions will briefly be unavailable. Switching will only take place as you start and end features, and only then if the *In feature* and *Not in feature* P(Y) modes differ.

The GPS Status Line

When P(Y)-code (i.e. PPS) positions are being received from a P(Y)-capable receiver, Asset Surveyor will indicate this fact by placing a 'P' (for P-code) on the GPS status line, in place of the '#' or 'R' character. For example:

SV 4/6 PDOP 2.4 P 23

Configuration/ GPS/Rover Options/ Output Options

The **OUTPUT** softkey on the *Rover options* configuration form leads to a sub-form where you can configure the output to be produced by your GPS receiver. The appendixes at the back of the *TDC2 Asset Surveyor Operation Manual* provides details of which outputs are supported by your specific GPS receiver, while Appendix I of the *TDC2 Asset Surveyor Operation Manual* provides details of the NMEA output format in particular.



Note – A range of output options can be purchased for the Series 4000 GPS receivers. Outputs from a Series 4000 receiver must be configured on the receiver's front panel; Asset Surveyor's *Output options* apply only to Pathfinder GPS receivers.

The *Output options* form looks as follows:

Output options	
Output:	
Baud rate:	9600

The two fields on this form are described below:

- *Output*. This can be *None* (the default), *NMEA* or *TSIP*.
- *Baud rate*. The *Baud rate* field lets you configure the baud rate at which your selected output (if any) will be transmitted by the GPS receiver.



Note – Although the baud rate for receiver outputs can be set in the *Output options* form, the other serial communications parameters (i.e. *Stop bits*, *Data bits* and *Parity*) must be shared with the incoming RTCM stream, if any. Return to the *Rover options* form and press **RTCM** to check that these serial parameters are appropriate for your output device.

Whenever you change the *Output options*, Asset Surveyor will remind you to check the *RTCM options* form and ensure that all of the serial communications parameters are set appropriately:

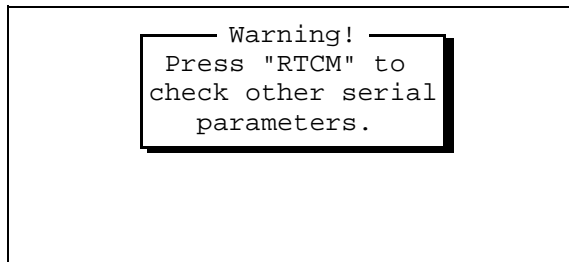

Caution – If you wish to use a Trimble Pathfinder GPS receiver in conjunction with an RTCM radio and another output device, the radio/modem and output device **must** use the same *Stop bits*, *Data bits* and *Parity*.



Caution – Some RTCM radio receivers may be confused or jammed if you attempt to 'transmit' data through them. Unless you are actually making use of a receiver output, and unless you have an appropriate splitter cable which separates the RTCM input line from the receiver's output line, you should leave the *Output* field set to None.

NMEA Output

The NMEA 0183 protocol is a widely used standard for communication with GPS devices and other navigational systems. Trimble Pathfinder GPS receivers which support the NMEA-0183 protocol can be configured by Asset Surveyor to output NMEA messages at a specified rate, and a subset of the available messages can be selected.

When you set the *Output* field in Asset Surveyor's *Output options* configuration form to NMEA, Asset Surveyor will extend the *Output options* form as follows:

Output options	
Output:	
Baud rate:	9600
Output interval:	5s
NMEA-0183 messages	
ALM:	No
GGA:	Yes
GLL:	No
GSA:	No
GSV:	No
VTG:	Yes
ZDA:	No

The additional fields on this form are:

- *Output interval*. The interval at which NMEA messages are to be emitted by the GPS receiver.
- *ALM*. Almanac information for each satellite.
- *GGA*. GPS time, position and fix-related data.
- *GLL*. GPS position fix, time of fix and status.
- *GSA*. GPS receiver operating mode, satellites used for navigation and DOP values.
- *GSV*. Number of visible satellites, satellite PRN numbers, elevation, azimuth and SNR values.
- *VTG*. Actual track made good and speed over ground.
- *ZDA*. UTC day, month, year and local time zone offset.

See Appendix I at the back of the *TDC2 Asset Surveyor Operation Manual* for a detailed description of each supported NMEA-0183 packet.

Once you save the contents of the *Output options* form with the *Output* field set to NMEA, your Pathfinder GPS receiver will begin to emit the selected NMEA-0183 messages at the configured *Output interval*, provided the receiver supports NMEA output.

TSIP Output

Trimble's Standard Interface Protocol (TSIP) is a complex binary protocol for controlling Pathfinder GPS receivers. This is the protocol which the Asset Surveyor software uses to communicate with your Pathfinder GPS™ receiver.

When you set the *Output* field in Asset Surveyor's *Output options* configuration form to TSIP, your Pathfinder Series GPS receiver will start to output TSIP messages to its auxiliary serial port. You may require a special cable to make use of this information. You cannot control the frequency or nature of the TSIP messages which will be output by the receiver, as these are determined by Asset Surveyor itself.



Note – Certain Pathfinder GPS receivers, including the Pro XL, are capable of emitting an electronic pulse precisely on each GPS second. This stream of pulses can be used for precise synchronization of external devices, and for correlation of external events with GPS times and positions. The Pro XL System *Operation Manual* provides cabling details for the Pro XL, and indicates which pin carries 1 PPS output for that receiver. No configuration of the Asset Surveyor software is required to obtain this 1 PPS output; the Pro XL emits it at all times. The Pro XR and Pro XRS receivers do not output PPS.

Configuration/ GPS/ Base Station Options

If you select *Base stn options* from the *Configure GPS* menu shown above, or if you select the *GPS* entry from the *Configuration* menu when in base station mode, then the following configuration form appears.

Base stn options	
Logging intervals	
Measurements:	5s
Positions:	30s
Log DOP data:	Yes
Pos mode:	Manual 3D
Elev. mask:	10°
SNR mask:	4.0
PDOP mask:	8.0
PDOP switch:	8.0
Audible click:	Yes
<input checked="" type="checkbox"/> RTCM	<input checked="" type="checkbox"/> ANTENNA



Note – Many of the fields in the *Base stn options* configuration form are similar to those in the *Rover options* form. Remember that the rover options will be used whenever you are not operating your Asset Surveyor as a GPS base station (i.e. when capturing data to a rover file, when outside *Data capture*, or when navigating). The base station options will be used *only* when you are operating the Asset Surveyor software as a GPS base station in conjunction with a Pathfinder GPS receiver. See page 7-76 for details of using the Asset Surveyor software as a GPS base station.



Note – The Asset Surveyor software cannot operate a Series 4000 GPS receiver as a base station, so the *Base stn options* configuration form is unavailable when you are connected to a Series 4000 receiver.



Note – The Asset Surveyor software can be used to control a real-time (i.e. RTCM-emitting) GPS base station, provided that your GPS receiver is a Pro XL, Pro XR, or Pro XRS, and has the appropriate firmware option installed. RTCM output is configured via the **RTCM** softkey.



Note – The Pro XR, and Pro XRS receivers can be operated as an Unattended Real-Time Base Station provided you have the necessary Unattended Real-Time Base Station power cable (P/N 32247).



Tip – Trimble recommends that you always log sufficient data at your base station to permit differential correction by postprocessing, as radio links rarely provide 100% coverage of a data collection site. However, if you wish to set up your Pro XL, Pro XR, or Pro XRS as a real-time base station only, and wish to leave it operating for a period of several days, you should set the *Measurements* and *Position* logging intervals to None.

Because many of the fields of the *Base stn options* configuration form are similar to those in the *Rover options* form, only the fields which differ significantly will be described here. Refer to the previous section on the *Rover options* configuration form for details of fields not described below.

Measurements

The primary task of a GPS base station is to log raw GPS measurements from satellites for use when differentially correcting rover files. In order to provide accurate differential corrections, raw measurements should be logged reasonably often. The maximum permitted measurement logging interval is 15 seconds. You can reduce the interval to a minimum of one second, but as this will result in up to 15 times as much data being logged by Asset Surveyor, you may find that your TDC2's storage is consumed very quickly and that differential correction of rover files is slow. The default setting of five seconds provides a good compromise between the quality of postprocessed positions and the storage space and processing time required.



Tip – For the best accuracy, you should ensure that the position logging interval for each GPS rover is an exact multiple of the measurement logging interval at the base station. If you set the position logging interval to a value which is *not* an exact multiple of the base station's measurement logging interval, the differential correction program will have to compute interpolated differential corrections. These will be less accurate than those computed when the logging intervals of the base station and rover(s) are synchronized.



Note – If your GPS receiver is capable of supplying synchronized carrier phase measurements, the Asset Surveyor software will request these when operating as a base station; otherwise, the Asset Surveyor software will log (unsynchronized) raw pseudorange measurements. Only receivers capable of supplying synchronized carrier phase measurements can be used as base stations for rovers operating in carrier phase mode.

Positions

The logging of GPS positions by a base station is not essential for differential correction. You can, however, choose to log a few positions in order to be able to graphically display the position of the base station in Pathfinder Office. If you set up a temporary base station on an unknown point, you may wish to log positions frequently to a base file. You can then differentially correct that base file against another (perhaps more distant) base station in order to discover the reference position for the temporary base station. Once this is known, you can use the local base file to correct local rover files.



Note – If you are operating your Pro XR or Pro XRS as an Unattended Real-Time Base Station, you should set the *Measurements* and *Position* logging intervals to None.

Log DOP Data

You can choose to log dilution of precision (DOP) values when operating as a base station, so that you have a record of the prevailing GPS conditions.

When the *Log DOP data* option is set to Yes, Asset Surveyor will log values of PDOP, HDOP, VDOP and TDOP (see page 6-17) whenever the PDOP value varies by 0.1 or more, provided the PDOP is below the configured PDOP mask. This provides a good record of each DOP situation which occurred throughout a survey period. The logging of DOP information will typically increase the size of a base file by approximately 2–3%.

Position Mode

You can operate a base station in any of the position modes which are permitted for a rover, i.e. Manual 2D, Auto 2D/3D, Manual 3D or Overdet. 3D. In general, however, you should be able to site a base station such that it is always able to track at least four satellites, so that there will be no need to use any mode other than Manual 3D (the default).

Elevation Mask

The default elevation mask for a GPS base station is 10° (as opposed to the default of 15° for rovers).



Caution – You *must* ensure that the elevation mask for the base station is set sufficiently low that the base can always track any satellites visible to the rovers. Remember that as the rovers get further from the base station, the difference between the elevation mask of the rovers and the base becomes more and more critical (due to the curvature of the earth). As a rule of thumb, the difference must be at least 1° for every 100 km between the base and the rover.

SNR Mask

The default signal-to-noise ratio mask for a GPS base station is four. The SNR mask does not influence the choice of satellites tracked by the base station, but does determine when the base station can log GPS positions. Note, however, that the logging of positions is not essential for differential correction.

PDOP Mask and PDOP Switch

The default PDOP mask and PDOP switch for a GPS base station are both slightly higher than their equivalents for rovers. This should ensure that the base station will always be able to log positions whenever a rover would be logging positions. Note, however, that the logging of positions is not essential for differential correction.

Antenna Options

You can press the **ANTENNA** softkey in the *GPS Base stn options* configuration form to preconfigure the antenna details prior to setting up a base station. When you actually set Asset Surveyor into base station mode, you will be asked to re-confirm the pre-configured base station antenna details. It is important that you enter the antenna details for your base station correctly, as the Pathfinder Office software uses these details to transform the reference position (on the ground) into the position of the GPS receiver's Antenna Phase Center (APC). This APC position is used by the Differential Correction Utility to correct your data .



Note – For base stations the measured antenna height must be Vertical.

Configuration/ GPS/Base Station Options/ RTCM Output

The Pro XL, Pro XR, and Pro XRS receivers support RTCM output as a receiver firmware option. Asset Surveyor can configure and control a real time base station provided the receiver is a Pro XL, Pro XR, or Pro XRS and has the appropriate firmware option installed.

The Pro XR and Pro XRS can be operated as an Unattended Real-Time Base Station without a datalogger if you have the appropriate cable. The Unattended Real-Time Base Station power cable (P/N 32247) supplies power to these receivers on Port B so that you may remove the data collector when using the Pro XR or Pro XRS as an Unattended Real-Time Base Station. Contact your local Trimble sales office to order this accessory.

If you require the data for postprocessed differential correction, you will need to have the TDC2 connected to the Pro XR or Pro XRS base station at all times.



Note – The Pro XL cannot be operated as an Unattended Real-Time Base Station.

If you are using a Trimtalk™ 450, 450S, or 900, a Trimmak™ I and II, or a Pacific Crest RFM96W with the Pro XR or Pro XRS you will need to purchase the RTCM OUT cable (P/N 32871) which connects to the Pro XR or Pro XRS on Port A, replacing the NMEA/RTCM cable (P/N 30232-00). The RTCM OUT cable has a Lemo connector on the other end for connection to the radios listed above.



Note – A Lemo adapter cable, supplied by Pacific Crest, is required to connect the RTCM OUT cable (P/N 32871) to the RFM96W radio.

If you are using a Pro XL, or using a non-Trimble radio with the Pro XR or Pro XRS, you will need your own cable to connect from your radio to the supplied NMEA/RTCM cable in Port A.

Press the **RTCM** softkey on the *Base stn options* configuration form to configure a real time base station. Refer to your *Receivers Operation Manual* for details on how to connect a telemetry link to your receiver.



Note – When connected to a GPS receiver which does not support RTCM output, the **RTCM** softkey will not appear.



Note – The **RTCM** softkey will not appear if a base station file is currently open.

The *RTCM output options* configuration form looks as follows:

RTCM output options	
RTCM output mode:	Off
RTCM station:	1
RTCM messages:	Type 1
Message interval:	5s
Message suffix:	None
Baud rate:	9600
Data bits:	8
Stop bits:	1
Parity:	None
CTS flow control:	Off
CTS xmit delay:	0ms
RTS mode:	High
RTS edge delay:	0ms

The various fields in this form are described below:

- *RTCM output mode*. By default, RTCM output from a base station is disabled (Off). You can enable RTCM output by setting the value of the *RTCM output mode* field to On.

- *RTCM station.* Every RTCM base station must specify an ID, which is a number in the range 0 to 1023. This ID number identifies the RTCM station and allows roving GPS receivers to specify a particular base station which they wish to use. The default *RTCM station ID* is 1.
- *RTCM messages.* When RTCM output is enabled, your GPS receiver will emit a variety of RTCM messages. The most important (and most frequent) of these messages will contain satellite pseudo-range corrections, as measured by the base station receiver. These corrections are used by roving receivers to correct the GPS positions which they compute. The RTCM standard allows for two main types of pseudo-range corrections, referred to as 'Type 1' and 'Type 9' messages. Each Type 1 message contains pseudo-range corrections for all satellites currently tracked by the base station, whereas Type 9 messages split pseudo-range corrections for the set of tracked satellites over several messages. Type 9 messages are used by the U.S. Coast Guard beacons, as they allow the use of telemetry links with lower throughput.
- *Message Interval.* The message interval determines the rate at which the selected RTCM message type (Type 1 or Type 9) will be emitted by your GPS base station. The default of 5 seconds tends to provide a reasonable compromise between optimal accuracy (which would be achieved with a 1 second message interval) and the throughput of typical telemetry links.
- *Message Suffix.* Each RTCM message can be followed by no suffix (the default), an ASCII carriage-return character (CR), an ASCII line-feed character (LF) or a carriage-return/line-feed pair (CR/LF).
- *Baud rate, Data bits, Stop bits, Parity.* These four fields allow you to specify the serial parameters to be used by your telemetry link. This is necessary for your GPS receiver to encode the RTCM data stream which is being carried over the telemetry link.

- *CTS flow control.* Many telemetry links transmit data quite slowly, and there is a need for flow control between the base station GPS receiver and the radio. The Pro XL, Pro XR and Pro XRS implement hardware flow control using a CTS (Clear To Send) line. By default, CTS flow control is Off, meaning that the receiver will send data regardless of the state of the CTS line.
- *CTS xmit delay.* This field lets you specify a delay, in milliseconds, between when the radio raises the CTS line and the GPS receiver continues to transmit RTCM data. If *CTS flow control* is Off, the *CTS xmit delay* will still be used to delay transmission of data by the specified period. By default, this delay is 0 milliseconds. The *CTS xmit delay* allows for radios which require a brief ‘warm up’ period before receiving data for transmission.
- *RTS mode.* This field lets you specify the RTS mode, which can be one of the following values: Rx (for ‘receive’, meaning that the RTS signal will be asserted by the receiver when its receive buffer is nearly full and input must stop), Tx (for ‘transmit’, meaning that the RTS signal will be asserted when the receiver has data ready to output), High (meaning that the RTS signal is always asserted by the receiver), and Low (meaning that the RTS signal is never asserted by the receiver). The default *RTS mode* is High.
- *RTS edge delay.* The RTS trailing edge field lets you specify a delay for the deactivation of the RTS signal after the last bit of data is sent. This can be useful in radio data transmission systems where RTS is used for the Push-to-talk signal.



Caution – It is very important that you match your RTCM output serial parameters with the requirements of your transmitting and receiving radios. Any errors made when specifying serial parameters can cause the RTCM link to fail.



Note – RTCM output is also available on Series 4000 GPS receivers with appropriate firmware options installed. The Asset Surveyor software will not attempt to control RTCM output from a Series 4000 receiver, however you can configure this via the receiver's front panel.

Configuration/ Coordinate System

Trimble's GPS receivers provide you with your position anywhere on the earth's surface. GPS positions are normally expressed as latitudes and longitudes relative to a mathematical model called a datum. The datum used by GPS is called the World Geodetic System 1984 datum (or 'WGS-84'). A datum is defined by the relationship between an ellipsoid and an origin point. An ellipsoid is a three dimensional surface shaped like a squashed sphere, which approximately models the shape of the earth (either as a whole, or over a particular part of the earth). The WGS-84 datum is defined in terms of the GRS80 ellipsoid.

For some applications (e.g. marine navigation and aviation), GPS latitudes and longitudes can be used directly.

For most land-based GPS applications, and particularly for GIS data capture applications, latitudes and longitudes are much less convenient. Typically, a GIS will represent the coordinates of geographic features in a locality of interest using a rectangular grid (running North and East) and will presume that the earth is locally flat. A local ellipsoid can be defined to provide a good approximation to the shape of the earth in that locality. A datum transformation and a map projection are then used to transform coordinates from this local ellipsoid to the GIS's flat-earth model.

Heights can be displayed by Asset Surveyor relative to either a local ellipsoid, or an empirically defined surface known as the geoid. This surface (illustrated in Figure 5-1) is of constant gravitational equipotential and approximates mean sea level.

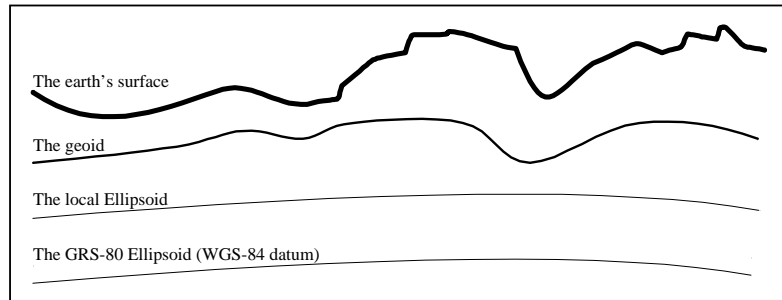

Figure 5-1 Coordinate System Models

In summary, there are three models for describing geographic locations:

- The flat North, East model of the GIS, possibly with Heights as well.
- The curved local ellipsoid, used by the GIS as a model of the earth's surface locally.
- The curved GRS-80 ellipsoid, used by GPS as a model of the earth's surface as a whole.

These models can describe heights as being relative to either:

- An ellipsoid.
- or
- The geoid (mean sea level).

In order to capture the positions of features using GPS (and hence the WGS-84 datum) and then send them to a GIS as North, East coordinates, the GPS latitudes and longitudes need to be processed in a number of ways:

- They need to be transformed from latitudes, longitudes and altitudes on the WGS-84 datum into latitudes, longitudes and altitudes on the local datum. This operation is called a datum transformation.
- Once the coordinates are expressed as latitudes and longitudes on the local datum, they must then be projected into North and East values on a flat grid, using an operation called a map projection.
- Finally, if altitudes are to be stored by the GIS, they need to be transformed from heights above the GRS-80 ellipsoid to heights above some other reference level. The most common reference level is the geoid, more commonly referred to as mean sea level. The Asset Surveyor software and Trimble's Pathfinder Office software both contain a geoid separation model which enables them to transform altitudes relative to GRS-80 into heights relative to mean sea level.



Note – The geoid separation models used by Asset Surveyor and Pathfinder Office differ in accuracy. The Asset Surveyor software is necessarily approximate, while Pathfinder Office is more accurate. If you require altitudes relative to a different reference level, or relative to a more accurate (perhaps local) mean sea level mode, you will need to process the heights in Pathfinder Office before exporting them to your GIS.

Asset Surveyor lets you specify a datum transformation and a map projection, so that you can see your GPS position (and the position of features you may have recorded) in your local coordinate system. This makes it easy for you to check your position or navigate using a map produced by your GIS.



Note – Asset Surveyor lets you specify that heights will be shown relative to your local ellipsoid, or relative to mean sea level. Configuration of the *Altitude reference* is described on page 5-80.

For your convenience, Asset Surveyor bundles up the complexities of datum transformations and map projections, and hides these complexities behind the common names for the coordinate systems with which you may be familiar. Each named coordinate system has an associated datum (which encapsulates an ellipsoid) and a number of zones (each of which is a named instance of a particular map projection).

You can create your own coordinate systems using the ASSETED utility program described in Appendix H of the *TDC2 Asset Surveyor Operation Manual*. With the set of pre-defined coordinate systems supplied by Trimble this should rarely be necessary.

Configuration/ Coordinate System/ Selection

When you select the *Coordinate system* entry from Asset Surveyor's *Configuration* menu, a menu of available coordinate systems will pop up:

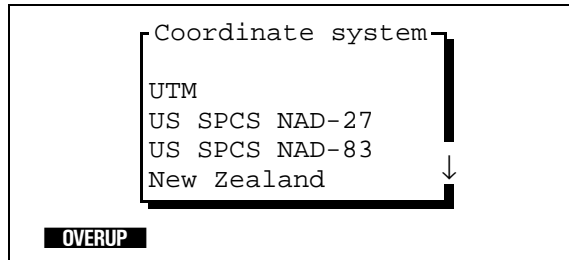

You can select a coordinate system from this menu by highlighting the entry and pressing  (or by using a first-letter search). After selecting a coordinate system you can select a specific *zone* *within* that coordinate system.



Tip – The Asset Surveyor software disk contains a predefined coordinate system file (ASCOORD.DAT) which you can load into your TDC2 using Pathfinder Office. You can edit this file on your PC using the ASSETED utility. Some of the pre-defined coordinate systems are described in the following sections. The creation and editing of coordinate systems, datums and zones using ASSETED is described in the *TDC2 Asset Surveyor Operation Manual*.



Note – The **OVERUP** softkey lets you configure and enable display of coordinates using the Trimble *Over and Up*TM map referencing system.

Configuration/ Coordinate System/ Selection/ Latitude/Longitude

The Asset Surveyor system supports a *Latitude/Longitude* coordinate system, whether or not you have loaded the file of pre-defined coordinate systems.

When you select *Latitude/Longitude* from the menu of available coordinate systems, you will be asked to select the datum relative to which latitudes and longitudes should be displayed:

Latitude/Longitude
Datum:

The *Datum* field lets you pop up a menu of available datums. Once you have selected a datum, press to save your selection of the *Latitude/Longitude* coordinate system.



Note – If you have not loaded the file of pre-defined coordinate systems, the only datum available will be WGS-84.

The *Latitude/Longitude* coordinate system is unique in that it has no ‘zones’, as such. Once you have chosen this coordinate system and have selected a datum, all positions displayed by Asset Surveyor will be shown as latitudes and longitudes relative to the selected datum.

Configuration/ Coordinate System/ Selection/ UTM

The Asset Surveyor system supports a *UTM* coordinate system, whether or not you have loaded the file of pre-defined coordinate systems.

UTM is an abbreviation for ‘Universal Transverse Mercator’, a system which uses Transverse Mercator map projections and a set of country-wide datums to span most of the earth’s surface. In order to use UTM at a specific location, you need to know which datum to use, which UTM *zone* you are in, and which hemisphere (north or south) you are in. There are 60 UTM zones, numbered 1 to 60, starting at the International Date Line and proceeding in an easterly direction around the earth, in steps of 6°.

When you select *UTM* from the menu of available coordinate systems, Asset Surveyor displays a form where you can specify the zone, the datum, the hemisphere and the scale factor:

UTM	
Zone:	
Datum:	?
Hemisphere:	Northern
Scale:	0.999600000

AUTO

When you first select a UTM coordinate system, Asset Surveyor will use the most recent GPS position (or the specified *Initial position*, if a current GPS position is unavailable) to ‘guess’ which UTM zone you are in. You should check that it has guessed correctly, and modify any field which is incorrect.



Tip – You can press **AUTO** to get Asset Surveyor to take a new guess at your UTM zone, based on the most recent GPS position (or the *Initial position* if a current GPS position is unavailable).

If you wish to manually enter a zone, you should type a number between 1 and 60 (inclusive) into the *Zone* field. You should then select a datum from the menu in the *Datum* field, and select the appropriate *Hemisphere*.

The *Scale* field is used to specify the scale factor which should be used for this UTM zone. The default value of 0.9996 is very common for UTM zones, but certain zones and applications use different scale factors.



Caution – It is very important that you specify the correct datum when using UTM. Traditionally, the NAD-27 datum has been used for UTM throughout the United States, but recently the NAD-83 datum has been used as the U.S. base for UTM in some applications. If you wish Asset Surveyor to display GPS positions which are compatible with UTM maps produced by your GIS, you must ensure that the UTM zone, datum and scale factor used by the GIS are all entered into Asset Surveyor correctly.

Once you have checked that Asset Surveyor's guess is correct, or entered the zone manually, press to save your choice of UTM zone. Once you have chosen the UTM coordinate system and accepted a zone, all positions displayed by Asset Surveyor will be shown in UTM coordinates.





Note – Asset Surveyor will warn you if you to specify a UTM zone which is further than two zone widths (i.e. 12°) of longitude from the current GPS position. You can still save the configuration form, but before doing so you should check that the zone which you have specified is indeed correct.

Configuration/ Coordinate System/ Selection/ Other

Apart from the special *Latitude/Longitude* and *UTM* coordinate systems, your Asset Surveyor system comes with a selection of pre-defined coordinate systems which can be loaded onto your TDC2, as described on page 7-51. You can also edit these pre-defined coordinate systems, or create new ones using the ASSETED utility program.

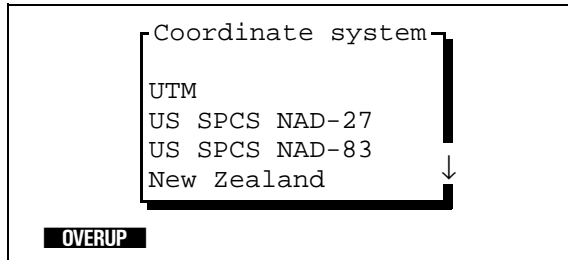
The following examples presume a selection of Trimble's pre-defined coordinate systems have been loaded onto your TDC2:



To select a coordinate system from this menu, move the highlight to the entry you require and press . If, for example, you wished to use a U.S. State Plane coordinate system under the NAD-83 datum, highlight 'US SPCS NAD-83' and select it. Once you have selected a coordinate system, Asset Surveyor will ask you to select a zone within that coordinate system, by popping up a menu of applicable zones. For the US SPCS NAD-83 coordinate system, these range from:

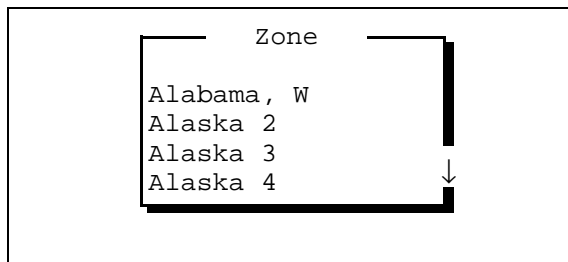

to:

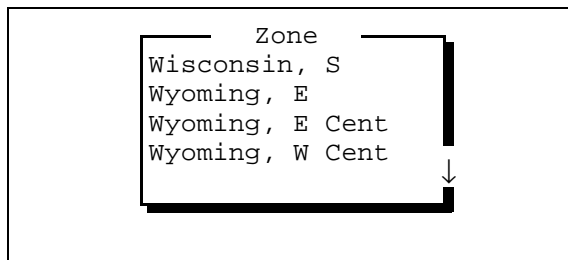

You should be able to easily identify the correct U.S. State Plane zone from this menu. Select it using , and from that point on Asset Surveyor will display positions as coordinates in the selected State Plane zone.



Note – After selecting the appropriate coordinate system and zone, you should also select the *Units* in which you wish Asset Surveyor to display coordinates, page 5-75 describes how to configure Asset Surveyor's *Coords* units.

Configuration/ Coordinate System/ Selection/ Over and Up

The Trimble *Over and Up*TM map referencing system is a very convenient way to represent coordinates on a paper map. Rather than viewing or entering coordinates as latitudes and longitudes, or as northings and eastings, all coordinates are expressed as paper distances from a reference position somewhere on your map.

If you press the **OVERUP** softkey *after* selecting a coordinate system, the *Over and Up* configuration form will appear:

Over and Up	
Mode:	
Reference position	
North:	?
East:	?
Scale (1:):	?
WAYPT	

By default, *Over and Up* mode is disabled. You can enable it by changing the *Mode* field from Off to On. Asset Surveyor will allow you to enable *Over and Up* mode only if you supply non-null coordinates for the *Reference position* and the map's *Scale*.



Note – The Reference position waypoint coordinates must be entered in terms of the **currently selected** coordinate system. The **WAYPT** softkey can be used to select a pre-entered waypoint as the reference position for your map.

Once you have entered appropriate values, press **OK** to save the *Over and Up* settings.

When you subsequently view positions (e.g. the current GPS position, the position of a captured feature, or that of a waypoint), Asset Surveyor will show these positions relative to the *Over and Up* reference position, in paper units. The position will be shown as Left or Right of the reference position, and either Up or Down from the reference position. If your configured distance units (see the *Units and Display* configuration form) are metric, the *Over and Up* distances will be shown in centimeters (cm); otherwise they will be shown in inches (in).



Note – *Over and Up* mode will only work with maps which are aligned to True north.



Caution – Remember to change your *Over and Up* settings whenever you change maps!

Configuration/ Units and Display

When you select the *Units and display* entry from Asset Surveyor's *Configuration* menu, the following configuration form will appear:

Units and display	
Units	
Coords:	Meters (m)
Height:	Meters (m)
Distance:	Meters (m)
Velocity:	Km / Hour
Angles:	Degrees (°)
Angle fmt:	DD.MMSSss
Order:	North/East
Altitude ref:	MSL
North ref:	True
Magnetic decl:	Auto
Null string:	?
Language:	English
Keypad:	ABC...XYZ

Asset Surveyor lets you configure many of the ways in which it will display information on the TDC2's screen. The default values for each field are as illustrated above. The configurable unit and display style fields are described in detail in the following sections.

Configuration/ Units and Display/ Units

Asset Surveyor displays units on a number of fields, and permits the specification of units when values are entered into these fields. Five classes of units can be configured:

- *Coords* units
- Vertical *Height* units
- Horizontal *Distance* units
- *Velocity* units
- *Angle* units.

If you position the highlight on any of these fields in the *Units and display* configuration form and press , Asset Surveyor will pop up the menu of units available for that field.

For *Coords* values, the permitted units are:

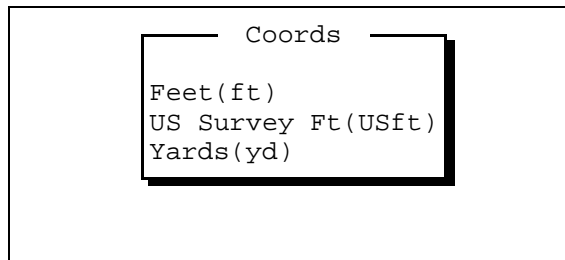

The image shows a screenshot of a software menu. At the top, the word "Coords" is centered. Below it, a list of three options is displayed: "Feet (ft)", "US Survey Ft (USft)", and "Yards (yd)". The list is enclosed in a rectangular box with a thick border.

For *Height* values, the permitted units are:

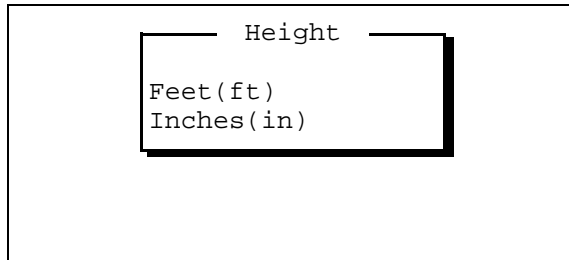

For *Distance* values, the permitted units are:

For *Velocity* values, the permitted units are:

Velocity
Feet/Second (ft/s)
Km/Hour (km/h)
Miles/Hour (mph)
Knots (kt)

For *Angular* values, the permitted units are:

Angles
Gradians (gon)
Rhumbs (rh)
Mils (mil)



Note – The configured units for *Angles* affect only the angles displayed when navigating, measuring between waypoints and entering offsets. They do not affect the bearings shown in the GPS *Satellite info* form and they have no effect on the entry or display of latitudes or longitudes (which are always entered and displayed in degrees with optional minutes and/or seconds).

You can select convenient units for *Coords*, *Height*, *Distance*, *Velocity* and *Angles*, and then move on to the other *Units and display* fields.

Configuration/ Units and Display/ Angle Format

You can configure the format for the entry of angles which use degrees (including latitudes and longitudes) into Asset Surveyor fields. The available formats are:

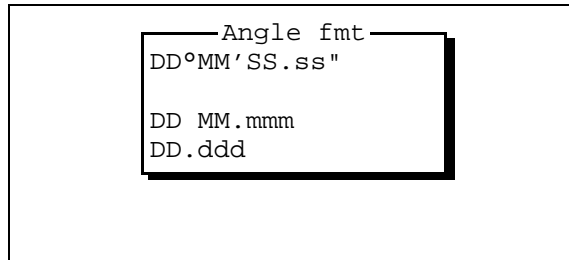

All full angles are *displayed* in the *DD°MM'SS.ss* format. Angles can also be entered in this format by typing each punctuation character, by selecting them from the **UNITS** menu, or by separating each of the components of the angle by a space.

The default *DD.MMSSss* format lets you enter a full angle in degrees, minutes, and seconds with the minimum of additional punctuation.

The *DD MM.mmm* format lets you enter an angle as degrees and decimal minutes, with a space character as punctuation to separate the two components.

The *DD.ddd* format lets you enter an angle in decimal degrees.



Tip – When entering latitudes and longitudes, remember that these are signed values, with the sign being used to indicate the hemisphere (North or South for latitudes, East or West for longitudes). You can enter the sign as '+', '-', 'N', 'S', 'E' or 'W', at either the start or end of the field. If you do not specify a sign then Asset Surveyor will default to the hemisphere in which you are currently operating, as determined by your most recent GPS position.

Configuration/ Units and Display/ Order

Whenever Asset Surveyor displays a position, it will show *North*, *East* and *Altitude* fields (or *Latitude*, *Longitude* and *Altitude* fields, if the current coordinate system is *Latitude/Longitude*).

You can choose the order of the first two fields of each position (i.e. *North/East* versus *East/North*, or *Lat/Long* versus *Long/Lat*) by changing the value in the *Order* field of the *Units and display* configuration form:

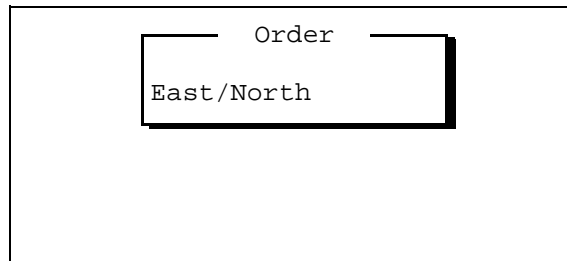

The image shows a screenshot of a configuration form. It features a large rectangular box with a thin border. Inside this box, centered, is a smaller rectangular box with a thick border. Above this inner box, the word "Order" is written. Inside the inner box, the text "East/North" is displayed, indicating the selected configuration for the order of the first two fields.

The default order is *North/East* (or *Lat/Long*).

Configuration/ Units and Display/ Altitude Reference

When Asset Surveyor displays a position, the altitude component of that position will be displayed as a height above (or below) either the current ellipsoid (i.e. datum) or mean sea level. Altitudes relative to the ellipsoid are precise, but may be meaningless for many applications, as altitudes shown on maps are usually relative to mean sea level. When Asset Surveyor displays altitudes relative to mean sea level these are approximate, having been derived from Asset Surveyor's internal mean sea level model. This model is typically accurate to within 2 to 5 meters.

You can change the altitude reference by changing the value of the *Altitude ref* field in the *Units and display* configuration form:

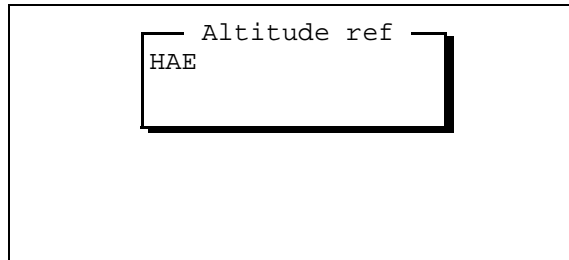

A screenshot of a configuration form. The form has a rectangular border. Inside, there is a label 'Altitude ref' at the top. Below the label is a text input field containing the text 'HAE'.

The abbreviation for height above ellipsoid is *HAE*, and that for mean sea level is *MSL*. The default altitude reference is mean sea level.

Configuration/ Units and Display/ North Reference

Whenever Asset Surveyor displays a *bearing* (i.e. an angle other than a latitude or a longitude), it does so relative either to true north or to magnetic north. True north is more useful if you are navigating relative to a background map, while magnetic north is best if you are navigating with the assistance of a magnetic compass. You can change the north reference via the *North ref* field in the *Units and display* configuration form:

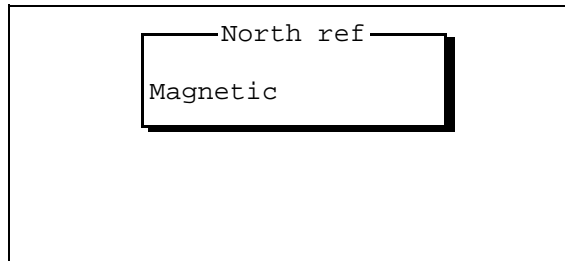

The image shows a screenshot of a configuration form. A rectangular box contains a dropdown menu. The text 'North ref' is positioned above the dropdown. The dropdown menu is open, showing the word 'Magnetic' as the selected option.

By default, the *North ref* is True. The difference between true and magnetic north depends on where you are on the earth's surface, and is called the magnetic declination. You can tell Asset Surveyor the current magnetic declination using the following field on the *Units and display* form.



Caution – Remember to set the *North ref* field to Magnetic before using a magnetic compass to enter offsets for features manually.

Configuration/ Units and Display/ Magnetic Declination

If you know the magnetic declination for your area (it is printed on most accurate maps), you can type it into the *Magnetic decl* field of the *Units and display* configuration form.



Note – If you move a significant distance you may need to update a manually-entered magnetic declination.

Because you may not always know your magnetic declination, or may prefer not to have to update it as you move about, Asset Surveyor provides an **AUTO** softkey when you are entering a value into the *Magnetic decl* field, for example:

Units and display	
Units	
Coords:	Meters (m)
Height:	Meters (m)
Distance:	Meters (m)
Velocity:	Km / Hour
Angles:	Degrees (°)
Angle fmt:	DD.MMSSss
Order:	North/East
Altitude ref:	MSL
North ref:	True
Magnetic decl:	<input type="checkbox"/>
Null string:	?
Language:	English
<div style="display: flex; justify-content: space-around; margin-top: 10px;"> AUTO UNITS - </div>	

When you press **AUTO**, Asset Surveyor inserts the special value Auto into the *Magnetic decl* field. From then on, whenever Asset Surveyor requires the magnetic declination, it will consult its internal magnetic declination table, based on your current location.



Tip – You should only need to enter explicit declinations when you are navigating over reasonable distances, entering magnetic offsets for features (with or without a laser rangefinder) or when there is a local variation in the earth’s magnetic field. Asset Surveyor’s declination table models the earth’s overall magnetic field. It does not take any account of local variations due to such things as mineral deposits, etc. If you need to temporarily enter a precise declination for a particular area, remember to change back to *Auto* when you leave that area.



Note – In order to compute your magnetic declination automatically, Asset Surveyor needs to know where in the world you are. It uses the most recent GPS position, or the configured *Initial Position*, if no GPS positions are currently available. Until Asset Surveyor knows your *Initial Position*, it will treat True and Magnetic north as being identical.

Configuration/ Units and Display/ Null String

Whenever Asset Surveyor has no value for a particular field in a form, it displays the *Null* character string, which by default is the single character '?'. Usually, you will not be permitted to save a form if one or more of its fields still have the null value, but occasionally a field will be permitted to remain null.

You can change the null character string by editing the *Null string* field in the *Units and display* configuration form. You can use any character string for the null value, but the null string should be distinctive and preferably brief.

When you are editing the *Null string* field, Asset Surveyor displays two softkeys:

- You can press **SPACE** to change the *Null string* to a single space character.
- You can press **SYMB** to insert a special character into the *Null string*.

Configuration/ Units and Display/ Language

The Asset Surveyor software has been translated into a number of languages. Once these languages have been loaded onto the TDC2 you can change the language. With the *Language* field highlighted, press  to pop up the menu of languages available on your TDC2:

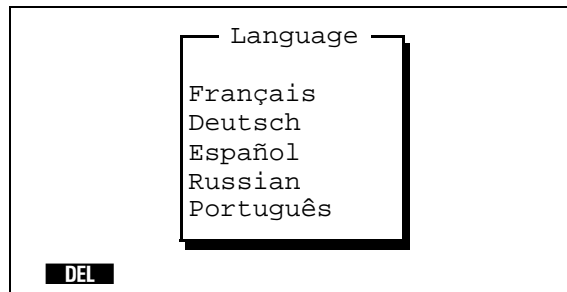

You can change languages by selecting another language from this menu.

The distribution disk for the Asset Surveyor software contains each of the language files supported at the time of purchase. If the language you require is not on that disk, please contact your Trimble distributor, as new translations of the Asset Surveyor software may be available. Refer to the *Data Transfer Utility Software User Guide* for instructions on how to load new language files into your TDC2.

To delete an unwanted language, highlight it and press **DEL**. You cannot delete the default language, which is English.

Configuration/ Units and Display/ Keypad

The Asset Surveyor software can be displayed in languages which do not use the normal Roman alphabet (i.e. A, ..., Z). For example, the Russian language uses the Cyrillic alphabet.

In order to use Asset Surveyor when running in a language such as Russian, it is necessary to map the TDC2's , , , ..., keys to letters in the Cyrillic alphabet. The *Asset Surveyor release notes* illustrates the mapping from Roman to Cyrillic letters.

When running Asset Surveyor in Russian, you will generally wish to enter all information using the Cyrillic alphabet. Occasionally, however, it will be necessary to enter Roman letters (e.g. when entering attributes for certain features, perhaps).

If you select a language such as Russian which uses the Cyrillic alphabet, the Asset Surveyor software will add a *Keypad* field to the *Units and display* configuration form. The *Keypad* field takes one of two values, the first being 'ABC...XYZ', and the second being the alphabet used by the selected language. In the case of the Russian language, this is **АБВ...ШЮЯ**.

You can switch between the Roman alphabet and the native alphabet of your selected language by changing the value of the *Keypad* field. This lets you mix the Roman and native alphabets freely when entering information on your TDC2's keypad.

Configuration/ Time and Date

When you select the *Time and date* entry from Asset Surveyor's *Configuration* menu, the following configuration form will appear:

Time and date	
24-hour clock:	
Time:	09:23:34 pm
Date fmt:	MM/DD/YYYY
Date:	10/02/1996 Wed

Asset Surveyor lets you check or set the local time and date, which is maintained by the clock hardware inside your TDC2. In addition, you can configure the formats in which times and dates will be displayed and entered.



Note – GPS time is extremely accurate, and Asset Surveyor will use GPS time to correct any errors in the TDC2's internal clock. It also applies an offset to obtain UTC (or GMT) time. Because Asset Surveyor does not know which time zone you are using, the TDC2's date will be aligned to within one day of the local date. Because some time zones are only 15 minutes 'wide', the TDC2's time will be aligned to the time zone that is within 7½ minutes of the TDC2's accurate clock. If you do not use the TDC2 with GPS for a long period, the TDC2's clock will drift away from the correct time; when you eventually reconnect to GPS, Asset Surveyor will realign the TDC2's clock again.

24-hour Clock

Asset Surveyor can operate using either a 12-hour clock (where 'am' and 'pm' are used to distinguish times in the morning from those in the afternoon) or a 24-hour clock. By default, Asset Surveyor will operate in 12-hour mode, but if you wish to view and enter times in 24-hour format, you can change the value of the *24-hour clock* field to Yes.



Note – Remember that even if you view times in 12-hour format, you can enter them in 24-hour format. Asset Surveyor will automatically convert them to 12-hour format before displaying them.

Time

The *Time* field is used for setting the local time of the TDC2. When you arrive in the *Time and date* configuration form, this value will be ticking over in pace with the TDC2's internal clock. If you change the time it will cease to tick over, and whatever time you have entered will be used to set the TDC2's clock hardware, but not until the form is saved.

When you are entering a new time Asset Surveyor will make a number of useful softkeys available (see Time Fields, page 4-29).



Caution – Take care that you enter the time correctly. If you are using a 12-hour clock, ensure that you have specified pm if appropriate.



Note – You can either configure the *Time* and *Date* fields to show the *local* time and date, or you can configure these fields to show *UTC time* (also known as GMT). Local time and date are generally more useful, especially if you wish to record the current time and date as attribute values. You can choose whether to name data files using local or UTC time by pressing the **TIME** softkey in any of the *Create file* forms.

Date Format

The three supported date formats are:

- DD/MM/YYYY
- MM/DD/YYYY (the default)
- YYYY/MM/DD

To change Asset Surveyor's date format edit the *Date fmt.* field of the *Time and date* configuration form.

Date

The *Date* field is used for setting the local date of the TDC2.

When you are entering a new date Asset Surveyor will make a number of useful softkeys available (see Date Fields, page 4-28).

Configuration/ Quickmarks

When you select the *Quickmark* entry from Asset Surveyor's *Configuration* menu, the *Quickmark options* configuration form appears:

Quickmark options	
Attributes:	
Confirm:	No

These two configurable fields are used to determine how the capture of point features using quickmarks should proceed.

Attributes

The *Attributes* field takes one of the values *Default* or *Repeat*. This field determines the source of the attribute values associated with the quickmarked feature. They will either be the default values specified when the data dictionary was defined (*Default*), or they will be the attributes of the most recent feature of that type (*Repeat*).

Confirm

Often when capturing point features using quickmarks you will not be able to enter attributes for these features at all (as you will be moving too rapidly). Sometimes, however, there are few enough attributes and the features can be clearly seen at speed, and it then becomes practical to record one or more attributes for quickmarked features. If the *Confirm* field's value is Yes, then just after each quickmark is recorded you will be given an opportunity to review and possibly edit the feature's attributes. If the *Confirm* field's value is No (the default), the quickmark will be immediately saved with default attributes determined solely by the *Attributes* field described above.



Note – When capturing point features by quickmarking them, Asset Surveyor will have fixed the feature's position and saved its default attributes **before** allowing you to edit these attributes (if the *Confirm* field's value is Yes). If, you then press (Esc) to exit the attribute review/editing form, the feature will not be abandoned or deleted. It will simply retain its default attributes.

Configuration/ Constant Offsets

When you select the *Constant offset* entry from Asset Surveyor's *Configuration* menu, the following menu of configurable constant offsets appears:

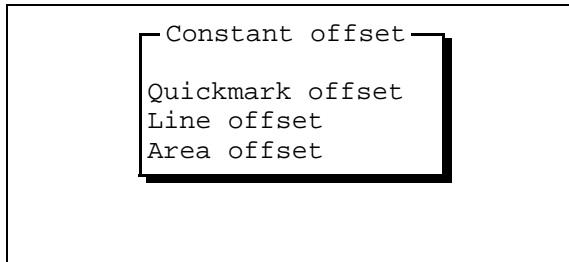

Asset Surveyor lets you specify a constant offset for point features, quickmarks, line features and area features.

You should configure a constant offset if most or all of the features you intend to capture can most conveniently be recorded by standing or moving past the feature at a distance. You can easily override the constant offset for the few features which may differ from the norm.

Point Features

A constant offset for a point feature consists of a bearing (an angle from either true or magnetic north), a range (slope distance), and an inclination (to the horizontal). If you select *Point offset* from the above list, the *Point offset* configuration form appears:

Point offset	
Bearing:	
Slope dist:	0.000m
Inclination:	0.0°
<input type="button" value="RESET"/> <input type="button" value="FORMAT"/>	

A constant offset can also be displayed and entered as a bearing, a horizontal distance, and a vertical distance:

Point offset	
Bearing:	
Horz. dist:	0.000m
Vert. dist:	0.000m
<input type="button" value="RESET"/> <input type="button" value="FORMAT"/>	

You can toggle between these two modes of offset display and entry by pressing the **FORMAT** softkey.

The default offset, as always, will be essentially no offset at all (i.e. zero). Once a non-zero *Constant offset* has been configured for point features, this will be automatically applied to each (normal, nested or carrier phase) point feature which is subsequently recorded.



Tip – You can use a laser rangefinder to fill in the three fields for a constant point feature offset, provided you configure constant offsets when the laser interface is active (i.e. under the *External sensors* entry in the *Utilities* menu, or under the **EXT** softkey in data capture).

Quickmarks, Lines and Areas

A constant offset for a quickmark, line feature, or area feature consists of a direction (left or right) relative to the direction of travel at the time the feature is recorded, a range (slope distance) and an inclination. If you select one of the *Quickmark offset*, *Line offset* or *Area offset* entries from the *Constant offset* menu then the following configuration form (with an appropriate heading) appears:

Line offset	
Direction:	
Slope dist:	0.000m
Inclination:	0.0°
<input type="button" value="RESET"/> <input type="button" value="FORMAT"/>	

A constant offset can also be displayed and entered as a direction, a horizontal distance and a vertical distance:

Line offset	
Direction:	
Horz. dist:	0.000m
Vert. dist:	0.000m
<input type="button" value="RESET"/> <input type="button" value="FORMAT"/>	

You can toggle between these two modes of offset display and entry by pressing the **FORMAT** softkey.

As with normal point features, once a non-zero offset has been configured, this will be applied to each feature of the corresponding type which is subsequently recorded.



Tip – You can use a laser rangefinder to fill in the last two fields for a line, area or quickmark constant offset, provided you configure constant offsets when the laser interface is active (i.e. under the *External sensors* entry in the *Utilities* menu, or under the **EXT** softkey in data capture). You must always enter the *Direction* field manually.



Note – Although a constant offset determines the default offset value which will be stored for a feature, this default offset can always be edited, either during the capture of that feature or later, when reviewing data.

The **RESET** softkey can be used to reset a configured constant offset to the default value (a zero offset).



Caution – If you forget to reset a constant offset when it ceases to be required, you may inadvertently record features which are offset when they should not be.

Configuration/ External Sensors

Asset Surveyor can interface to a wide range of external sensors and laser rangefinders equipped with an RS232 serial port. When Asset Surveyor receives a data message from an external sensor, it can log this data together with an associated GPS position, or it can log the sensor data as an attribute value for a feature.

Storage of Sensor Data

If data from a sensor is logged together with a GPS position, each sensor data message is logged as a separate UNINTERPRETED_SENSOR_DATA record in the Trimble SSF file format. You can use Pathfinder Office's Export Utility to output UNINTERPRETED_SENSOR_DATA records together with their associated GPS position. To ensure that the GPS position associated with each sensor message is as accurate as possible, Asset Surveyor records two GPS positions to 'bracket' the sensor message (just as it does for quickmarks) and Pathfinder Office uses a GPS time tag which is fixed to each UNINTERPRETED_SENSOR_DATA record to compute an interpolated GPS position for that record.

If a sensor message is stored as an attribute of a feature, it is stored in the same way as any other attribute. From that point on, Asset Surveyor and Pathfinder Office treat it as if you had typed it in, and you are free to edit the message if you wish.

Sensor messages are not actually interpreted by Asset Surveyor, whether they are stored as UNINTERPRETED_SENSOR_DATA records or as the attributes of features. You may need to edit these messages after producing ASCII or GIS output from Pathfinder Office, or it may be possible for you to write a program or script which will transform the raw sensor data into a more readable or usable format once the data has been imported into your GIS, database or CAD package.

Limitations of Asset Surveyor's ESP Interface

Asset Surveyor may not work with a particular external sensor unless each of the following conditions is met:

- The sensor must emit ASCII (7- or 8-bit) characters; Asset Surveyor does not support the use of an RS232 line to transmit other electronic pulses.
- The sensor must emit distinct messages of no more than 256 characters each. Each 'message' can be as small as a single character.
- The sensor must emit messages which can be delimited either by a recognizable prefix, a recognizable suffix, a maximum length or an elapsed period of time between messages. If the sensor emits messages whose format cannot be described in terms of these factors, Asset Surveyor will not be able to determine where one message ends and the next begins.
- The sensor must not emit messages faster than Asset Surveyor can process them. The actual throughput which can be handled by Asset Surveyor depends on a number of factors, including:
 - The connected GPS receiver,
 - The prevailing GPS conditions (i.e. number of visible satellites),
 - The amount of GPS data being logged,
 - The nature of the messages being received from the external sensor (i.e. the way in which they are delimited, the length of each message, etc.).



Tip – Trimble recommends that before purchasing an external sensor, you should always test the sensor with your Trimble Asset Surveyor/GPS system under a range of conditions to ascertain that the combination performs acceptably.

Configuration/ External Sensors/ Sensor 1/2



Tip – Configuration of the Asset Surveyor external sensor interface requires a reasonable understanding of how your sensor communicates via its RS232 port. You should always allow plenty of time for configuring and testing a sensor with Asset Surveyor before beginning data capture. There are often a number of ways in which to configure the external sensor interface to work with a particular sensor, and usually one way will be better than the others for a given application.

To configure Asset Surveyor to receive data from an external sensor, select *External sensors* from the *Configuration* menu; the following menu of sensors appears:

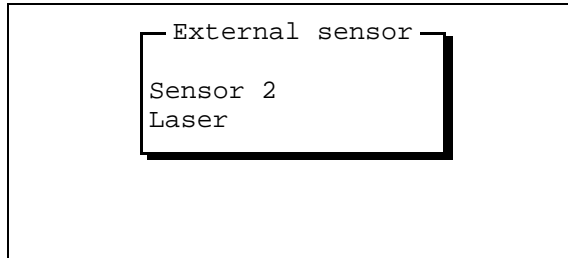

The Asset Surveyor software supports up to two configurable external sensors, which by default are named *Sensor 1* and *Sensor 2*. It also supports a single laser rangefinder interface, as described later in this chapter.



Note – Although you can pre-configure two external sensors, you can only connect and use one at a time.

If you select one of the two configurable sensor entries from the *External sensors* menu, Asset Surveyor will display that sensor's configuration form, which looks as follows:

Sensor 1	
Auto connect:	
Name:	Sensor 1
Channel:	0
Connect:	?
Disconnect:	?
Data request:	?
Intervals	
Point feature:	None
Line/area:	None
Not in feature:	None
Attribute:	None
Data received	
Prefix:	?
Suffix:	?
Max bytes:	?
Timeout:	0.100s
Audible click:	No
Status line:	No
COMMS	

The following sections describe each of these fields in detail:

Auto Connect

An external sensor can be activated manually, each time data capture commences. If the same external sensor is to be used every time you use your Asset Surveyor system, it may be more convenient to configure this sensor interface to automatically connect (i.e. activate) whenever data capture commences. This can be achieved by setting the value of the *Auto connect* field to Yes.

Name

Each external sensor can be assigned a more meaningful name than *Sensor 1* or *Sensor 2*. If, for example, you configured the first external sensor to interface to a Geiger counter, you might wish to rename it *Geiger counter*. The menu of external sensors would then look like:

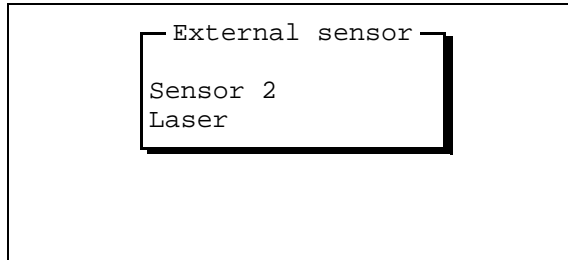

Channel

The *Channel* field lets you allocate a number in the range 0 ... 32767 to this sensor. The channel number will be attached to every UNINTERPRETED_SENSOR_DATA data record logged from this sensor, and could be used by Pathfinder Office or other postprocessing software to identify the sensor which originated a particular data record.

The default channel number is 0.



Note – The channel number is not related to the number of channels in your GPS receiver, and neither is it related to radio frequency channels. It is simply a number which you can assign to data received from a particular external sensor.

Connect and Disconnect

The *Connect* field specifies a character string which will be automatically sent by Asset Surveyor to the external sensor when the interface with that sensor is activated. It might be used to reinitialize the sensor, or to set it into the correct mode.

The *Disconnect* field specifies a character string which will be automatically sent by Asset Surveyor to the external sensor when the interface with that sensor is deactivated. It might be used to switch off the sensor, or reset its mode.



Tip – If either the *Connect* or *Disconnect* fields have a null value, they will not be sent to the external sensor. If you need to send to the sensor the same character(s) that make up your configured null string, you will have to enter them as hexadecimal codes, as described below.

As with all configurable character strings which can be sent to or received from the external sensor, the *Connect* and *Disconnect* fields allow you to include both printable and non-printable ASCII characters. Non-printable ASCII characters can be included in a field's value using a special *escape* character (the backslash character, '\').

When the backslash character is followed by two *hexadecimal* (base 16) digits, it is treated as a single ASCII character with a value equivalent to that two-digit hexadecimal number. For example,

- \01 is the hexadecimal value 01_{16} , or ASCII character 1.
- \4C is the hexadecimal value $4C_{16}$ or ASCII character 76. This character corresponds to the letter 'L'.
- \FF is the hexadecimal value FF_{16} , or 255. This is the largest ASCII character that can be specified.

Because it is difficult remembering the ASCII codes corresponding to special characters like carriage-return and line-feed, and because it is even more difficult converting these values to hexadecimal codes, Asset Surveyor provides a special **CODE** softkey. When you press this softkey, a menu of the first 32 ASCII characters appears:

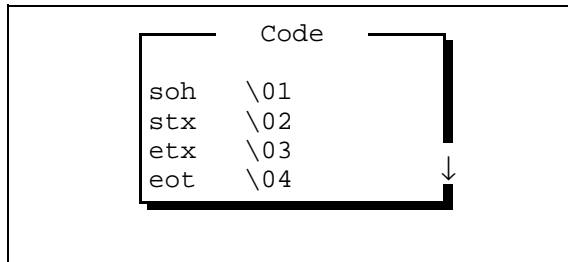

	Code
soh	\01
stx	\02
etx	\03
eot	\04

Each line of the menu shows an ASCII character's mnemonic name and the \XX code which is associated with that character. When you select a character code from this menu, Asset Surveyor inserts the \XX code into the field which you were editing when you pressed **CODE**.

The usual **SYMB** softkey will also be available for convenient entry of other printable characters (e.g. punctuation).

Data Request

The value of the *Data request* field is a character string which, if non-null, will be periodically sent to the external sensor. This is used to request data from the sensor if it requires an explicit request (many sensors emit data continuously, or when triggered by the user, and for these sensors the *Data request* field should be left null).

When entering a value for the *Data request* field, Asset Surveyor will make **SYMB** and **CODE** softkeys available, as described above.

If non-null, the *Data request* string will be periodically sent to the external sensor as determined by the *Intervals* fields, described on the following page. All data emitted by the external sensor will then be logged by Asset Surveyor.

If the *Data request* string is null, then whatever data is emitted by the external sensor will be logged at a rate determined by the *Intervals* fields, described below.

Intervals

There are three intervals applying to point features, line or area features, and when not recording a feature. These intervals are used for one of two purposes, depending on the value of the previous *Data request* field:

- If *Data request* is non-null, then depending on the context (whether in a feature or not, and if so, which type of feature), the appropriate interval will be used to periodically send the *Data request* character string to the external sensor. In this case, any response from the sensor will be logged.
- If *Data request* is null, then data which just arrives from the external sensor unsolicited will be logged at the interval appropriate to the context (whether in a feature or not, and if so, which type of feature).



Tip – If you have a sensor which emits data unsolicited, you do not need to set up any kind of *Data request* string. It is easy to forget that you **do** need to set one or more of the *Interval* fields to a value other than *None*, otherwise Asset Surveyor will not log any data received from the sensor. ***When all intervals are None, Asset Surveyor will not log any data from an external sensor.***



Note – As with all interval fields in Asset Surveyor, these fields can be filled in by pressing **ALL** or **NONE** or by typing an interval in seconds (or some other convenient unit of time).

Attribute

Data from an external sensor can be stored by Asset Surveyor in one of two ways:

- As independent UNINTERPRETED_SENSOR_DATA records. These can be output from the Pathfinder Office Export Utility with interpolated GPS positions, and fed into processing software such as a contouring package. An example of an application which might store sensor data for contouring is a radiation survey where a Geiger counter is passed backwards and forwards over a nuclear waste storage site.
- As attributes of a feature. When sensor data is stored as an attribute, it is tied to a particular geographic feature. It can be output to a GIS along with all of the other attributes of that feature. An example of an application where sensor data should be stored as attributes is a forestry survey where each tree has a number of attributes, one of which is the tree's trunk diameter, which is measured using an electronic tree-caliper.

You specify which of these two methods of sensor data storage you require by configuring the *Attribute* field of the external sensor configuration form.

By default, the *Attribute* field will have the special value None, which means that sensor data is not to be stored as an attribute, but rather is to be stored as independent UNINTERPRETED_SENSOR_DATA records.

You can specify that you wish sensor data to be stored as an attribute by typing the name of the attribute to which you wish to associate this data. For example, the forestry application mentioned above might involve recording the following attributes for each tree:

	<<Tree>>
Species:	
Diameter:	?
Pruned:	Yes
To height:	3m
Date:	1/6/1994 Wed

To ensure that each measurement from the tree-caliper sensor goes into the *Diameter* attribute, you should configure the sensor's *Attribute* field to contain the character string *Diameter*.

When a message from an external sensor is received by Asset Surveyor, it is stored as an attribute value provided you are currently capturing a feature which has an attribute of the specified name, and provided:

- This attribute is a character string attribute which is long enough to hold the data,
or
- This attribute is a numeric attribute and it is possible to interpret the data from the sensor as a number (which must comply with the ranges permitted for this attribute).



Tip – Typically it is easiest to use a character string attribute to store sensor data. Remember to make the character string as long as the longest possible message from your sensor.



Caution – You must take care to ensure that the character string which you enter into the *Attribute* field exactly matches an attribute name in your current data dictionary. If it does not, Asset Surveyor will fail to store data from your external sensor into any attribute field. Attribute name-matching is not case sensitive.



Note – It is possible that more than one sensor data message may arrive during the capture of a particular feature. Each time a message arrives, Asset Surveyor will overwrite the value stored in the named *Attribute*. Therefore only the last sensor message per feature will actually be saved (when the feature itself is saved).



Note – When *Attribute* is set to None, and Asset Surveyor is storing ESP data as UNINTERPRETED_SENSOR_DATA records, the Asset Surveyor software will attempt to bracket each such record with at least two GPS positions (just as it does for quickmarks). This enables the Pathfinder Office software to compute an interpolated GPS position for each ESP data record, based on the time at which that record was recorded.

Data Received

The most complex part of configuring an external sensor interface is the description of the data stream which is emitted by the sensor. Data can be received from the sensor in response to a request, in a continuous stream, or when a switch or trigger is pressed on the sensor itself.

In order to correctly separate the messages which are emitted by the sensor, Asset Surveyor lets you describe how messages are structured using any combination of the following four fields:

- The *Prefix* field can be used to specify that each message from the sensor is prefixed with a constant sequence of characters. For example, all NMEA-compliant sensors output messages preceded with a '\$' character and one or more characters which identify the specific sensor. Enter the null string if you do not wish to specify a prefix.
- The *Suffix* field can be used to specify that each message from the sensor ends with a constant sequence of characters. For example, all NMEA-compliant sensors output messages terminated by carriage-return and line-feed characters. Enter the null string if you do not wish to specify a suffix.
- The *Max bytes* field can be used to limit the length of each message to a specific number of bytes. This length includes the length of any defined *Prefix* or *Suffix* strings, and Asset Surveyor will not allow you to specify a maximum number of bytes which is less than the combined length of the prefix and suffix. Enter the null string (by pressing **NULL**) if you do not wish to specify a maximum number of bytes. The maximum value permitted for the *Max bytes* is 242 (this is the limit permitted for UNINTERPRETED_SENSOR_DATA SSF records).

The *Timeout* field can be used to distinguish separate messages by a certain amount of elapsed time between them. When Asset Surveyor receives a character from the sensor, it starts a timer. If another character is not received from the sensor before the timer expires (i.e. before *Timeout* seconds have elapsed), Asset Surveyor considers the message is complete, and logs the characters it has received. If a character arrives before the timer expires, the timer is reset and the procedure repeats.

The default value for the *Timeout* field is 0.1 seconds (100 ms); the maximum permitted value is 0.5 seconds and the minimum is 0.0 seconds.



Caution – While Asset Surveyor is waiting for a *Timeout* period, it is unable to communicate with the GPS receiver. You should not specify a large *Timeout* value unless that is strictly necessary in order to process data from a particular external sensor.

Asset Surveyor uses a combination of the above fields to separate messages from an external sensor.



Note – You do not necessarily need to fill in all of these fields. A field is ignored by Asset Surveyor if its value is null.

Audible Click

If you want the TDC2 to ‘click’ each time data from an external sensor is received and logged, set the value of the *Audible click* field to Yes. The click is similar to, but audibly distinct from, the click emitted by the TDC2 when it logs a GPS position.

Status Line

To make the most of the TDC2’s screen, you will not usually want a separate status line for an external sensor. However for some applications, it may be crucial to be able to see when data is received from the sensor. In this case, set the *Status line* field to Yes in order to display a status line for the external sensor being configured.

The sensor's status line appears just above that for GPS (if GPS is running):

SensorName	4 / 6
SV 4/6 PDOP 2.4 # 23	

The sensor's status line shows the name of the sensor, followed by two numbers, separated by a slash ('/') character. The first of these is the number of messages received from the sensor and logged since the start or end of the last feature; the second number is the total number of messages received from the sensor and logged since Asset Surveyor started communicating with the sensor.

COMMS Options

At the bottom of the external sensor configuration form is a **COMMS** softkey. Press this to configure the RS232 communications protocol to be used when Asset Surveyor and the sensor are communicating.



Note – The **COMMS** softkey will not be available when the sensor has already been activated.

	Sensor 1
Serial port:	
Baud rate:	9600
Data bits:	8
Stop bits:	1
Parity:	None

This RS232 communications configuration form lets you specify all of the standard RS232 parameters:

- The *Serial port* field can be set to either *COM1:* or *COM2:*. The default serial port for external sensors is **COM1:**.
- The *Baud rate* field is a menu of available baud rates, up to a maximum of 38400 baud.
- The *Data bits* field is a menu permitting between 7 and 8 data bits to be specified.
- The *Stop bits* field is a menu permitting 1 or 2 stop bits to be specified.
- The *Parity* field is a menu permitting values of None, Odd and Even to be specified.

The RS232 configuration form requires a reasonable understanding of the RS232 concepts. If you enter any of these fields incorrectly, it is unlikely that Asset Surveyor will be able to communicate with your sensor.



Caution – It is easy to make an error when specifying the RS232 parameters for an external sensor. Be sure to test any configuration changes.

When you have entered values for each field, press to save the contents of this form and return to the external sensor configuration form.

Press again to save the entire definition of the external sensor, ready for use.

Configuration/ External Sensors/ Laser

If you select *Laser* from the *External sensors* configuration menu, Asset Surveyor will display the configuration form for laser rangefinders, which looks as follows:

Laser rangefinder	
Type :	
Auto-connect :	No

The laser *Type* can be Criterion 300, Criterion 400, ProSurvey 1000, Atlanta Advantage or Ledha-Geo. The laser interface can be configured to *Auto-connect* whenever you create or reopen a rover data file; this can be useful if you often or always use Asset Surveyor together with a laser rangefinder.

Having selected the type of laser rangefinder, and specified whether or not it should automatically 'connect', no further configuration of the laser rangefinder interface is required. Press to save the laser interface configuration form and return to the menu of external sensors.

Configuration/ TDC2 Hardware

If you select *Hardware (TDC2)* from the *Configuration*, Asset Surveyor displays the hardware configuration form:

Hardware (TDC2)	
LCD contrast:	32%
Backlight:	Off
Auto shutoff:	20
Key click:	On
Beep volume:	High
Free space:	986kB
TDC2 power	
Source:	External
External:	12.3V
Software ver:	3.30

The various configurable aspects of the TDC2 hardware are described in detail in the following sections.

LCD contrast

You can vary the contrast of the TDC2's LCD by changing the value of the *LCD contrast* field. You can also increase the contrast using `[Func] [B]` and `[Func] [A]` key sequences. Each time you press `[Func] [B]` the contrast will increase by 10%, and each time you press `[Func] [A]` the contrast will decrease by 10%.

Backlight

You can turn the TDC2's backlight on or off by changing the value of the *Backlight* field. You can also turn the backlight on or off by pressing `[Func] [E]`.

Auto shutoff

In order to maximize battery life, the TDC2 will switch off if no key is pressed for a period of time (unless it is operating as a GPS base station, navigating or capturing data to a rover file, in which case it will *not* turn off automatically). The value of the *Auto shutoff* field determines how long the TDC2 will wait after you last pressed a key on its keypad, before turning off. The minimum value permitted for *Auto shutoff* is one minute, and the maximum is 60 minutes.



Note – The *Auto shutoff* setting will not cause the TDC2 to turn off in File transfer mode, but after 10 minutes of inactivity Asset Surveyor will exit File transfer mode and return to the *Main menu*. Once File transfer mode has been exited, the *Auto shutoff* setting again becomes active and will switch off the TDC2 after the specified time has elapsed unless you press a key.

Key click

Whenever you press a key on the TDC2's keypad, the TDC2 will emit a 'click' to provide audible feedback. You can turn key clicks off by changing the value of the *Key click* field to *Off*.

Beep volume

Whenever Asset Surveyor emits a beep of any kind, it will do so either at high or low volume. You can select the volume by changing the value of the *Beep volume* field.

Free space

The *Free space* field shows you how much data file storage space remains on your TDC2. You cannot edit this field.

TDC2 Power

The next four fields provide information regarding the power source and external battery level currently detected by the TDC2 hardware and are not editable.

The *Source* field has values of Internal (if the TDC2 is running on its own internal batteries) or External (if an external source of power, such as the GPS receiver's battery, is being used to run the TDC2).

Software version

The *Software ver* field shows the Asset Surveyor software version currently loaded on the TDC2. You cannot edit this field.

6 GPS Operations Menu

This chapter describes the use of the Asset Surveyor software with Trimble GPS receivers. There are a number of variations between specific GPS receivers, some of which are noted here and others of which are described in the appendixes of the *TDC2 Asset Surveyor Operation Manual*.

GPS/ Activating

If you connect a supported Trimble GPS receiver to your TDC2 using the correct cabling and batteries, Asset Surveyor will start to communicate with the GPS receiver immediately after the TDC2 is turned on.

When communication with a GPS receiver is not already established, you can press **GPS** to cause Asset Surveyor to begin communicating with the GPS receiver.

If, for some reason, the Asset Surveyor software cannot communicate with the GPS receiver, the following message appears:

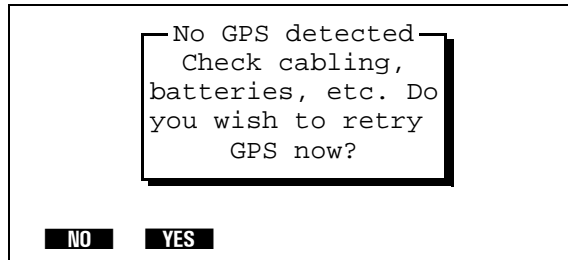

In this case, check that the cabling is connected firmly and correctly, that the batteries are connected and charged, and that your GPS receiver is switched on (if appropriate). Then press **YES** to the above question.

If the Asset Surveyor software and GPS receiver still do not establish communication, consult the Appendix referring to the receiver you are using, in the *TDC2 Asset Surveyor Operation Manual* or your receiver's *Operation Manual* for cabling and configuration details specific to the GPS receiver you are trying to use.

GPS/ Status Line

Once communication with a GPS receiver is established, Asset Surveyor beeps and displays the GPS status line. This single line (just above the line of softkeys) provides you with up-to-date information regarding the status of the GPS receiver:

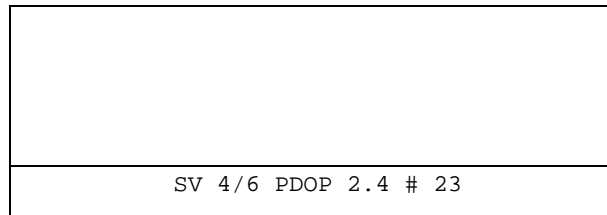

The various components of the GPS status line are as follows:

- ‘SV n/m ’ at the left of the status line shows the number of GPS satellites (‘space vehicles’, or SVs) being used to compute positions (n) and the number of satellites from which signals are being received (m). The number m is always at least as great as the number n .



Note – With the GPS receivers, there are circumstances under which one or more satellites will be unused. The most likely circumstance is when the signal from a particular satellite is weak (that is, below the SNR mask), or when a satellite has been marked as ‘unhealthy’ by the GPS Control Segment.

- ‘PDOP $xx.x$ ’ in the middle of the status line shows the current value of the PDOP heuristic. As discussed in the *Mapping Systems General Reference*, this provides an approximation to the accuracy of the GPS system, based on the geometry of the GPS constellation at any point in time. The smaller the PDOP value the more accurate GPS positions tend to be.

- ‘# yyy’ at the right of the status line shows the number of GPS positions that have been logged by Asset Surveyor for the current feature (if you are currently capturing data to a point, line or area feature), or the number logged since the end of the last feature (if you are logging data when not in a feature). When you are capturing a point feature and the number of logged positions for that feature ticks past the configured *Minimum posns* value, Asset Surveyor will emit a success beep.



Note – When RTCM differential corrections are being received, the ‘#’ character on the status line changes to an ‘R’. When P(Y)-code (i.e. PPS) positions are being received from a P(Y)-capable GPS receiver such as the Trimble Centurion, the ‘#’ character on the status line changes to a ‘P’ (for P-code).

When operating Asset Surveyor in carrier phase mode, the GPS status line will display the amount of carrier phase data collected at the current feature logging interval.

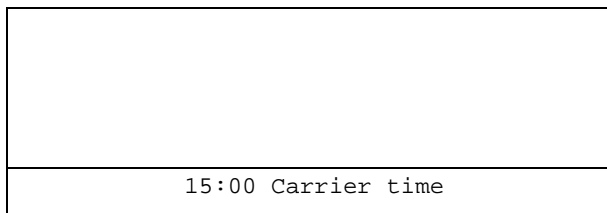

The GPS status line will also periodically flash messages such as:

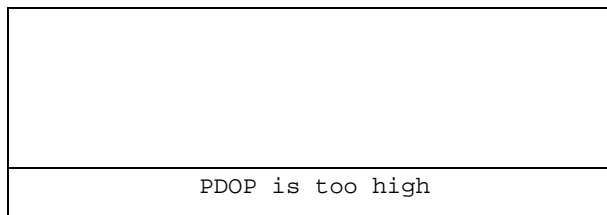

or:

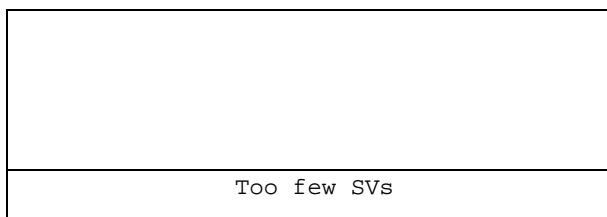

Most messages flashed on the GPS status line inform you of a condition which is preventing the computing or logging of GPS positions. When these conditions arise, Asset Surveyor will emit a warning beep and start to flash the appropriate message. When the condition ceases, Asset Surveyor emits a success beep to indicate that you can proceed with your survey and removes the flashing message from the status line.



Note – There can be more than one message flashing alternately with the regular contents of the GPS status line. Often conditions like high PDOP and insufficient satellites occur together, for example when driving beneath trees.

GPS/ 2D Altitude

If you activate the GPS receiver and have configured Asset Surveyor to use a two-dimensional position mode such as *Auto 2D/3D* or *Manual 2D*, Asset Surveyor will ask you to provide a 2D altitude before it proceeds to establish communications with the GPS receiver.

```
                2D altitude
Alt (MSL):
Entered at
Time:                11:15:23 am
Date:                03/02/1993 Wed
```

You must either enter a new 2D altitude or accept the previous value. Press to accept the 2D altitude and proceed with the GPS connection.

See page 5-14 for a description of configuring Asset Surveyor to use a 2D mode, and page 6-30 for a further description of entering 2D altitudes.

GPS/ Almanac

Most Trimble GPS receivers have internal battery-backed memory, in which is stored a current GPS almanac. This almanac describes the orbits of each of the GPS satellites in fine detail, and is used by the GPS receiver to determine which satellites it can expect to receive signals from at any point in time, and where these satellites will be in the sky at that time. Even now that the GPS satellite constellation is essentially complete, satellites are regularly removed from operation for servicing and testing, and it is important that your GPS receiver has an up-to-date almanac to ensure rapid acquisition of signals from all available satellites on startup.

Without an almanac, a GPS receiver can still acquire satellites and compute positions, but the initial acquisition of satellites will be slower (3–15 minutes) than it will be with an up-to-date almanac (30–45 seconds or less).

When operating with a Pathfinder GPS receiver, Asset Surveyor will record an almanac each time a GPS session takes place. When Asset Surveyor is subsequently used with a Pathfinder GPS receiver that does not have an almanac, it will load the pre-recorded almanac into the receiver's memory at the start of the session, thereby enabling the receiver to rapidly acquire satellites. While sending the almanac to a GPS receiver, Asset Surveyor will flash the message:

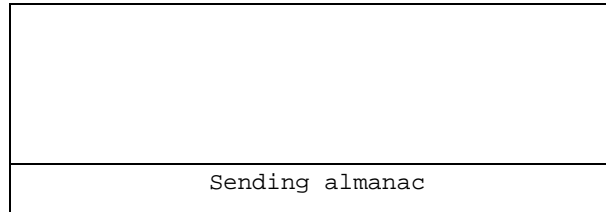

Asset Surveyor will not record an almanac from a Pathfinder GPS receiver until it can be sure that the receiver has a complete and up-to-date almanac. While it is recording an almanac from the receiver, Asset Surveyor will flash the message:

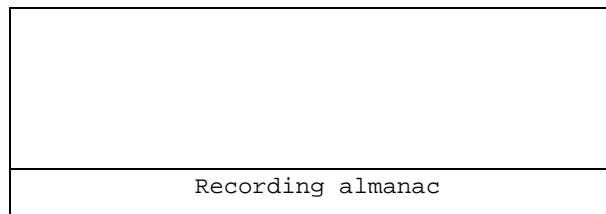

Tip – You can continue to use Asset Surveyor while it is recording an almanac; there is no need to stop and wait for the procedure to complete.



Note – Almanacs recorded by Asset Surveyor when operating with a Trimble Pathfinder GPS receiver can be transferred to Pathfinder Office for use in mission planning.

Initial Position

In addition to an almanac, a GPS receiver requires an approximate initial position and an accurate time if it is to rapidly acquire satellites on startup. Asset Surveyor can use the TDC2's accurate clock to ensure that it sends an accurate time to the GPS receiver, but it cannot determine your position without the aid of a GPS receiver. In order to avoid a Catch-22 situation, Asset Surveyor maintains an Initial position as part of the GPS configuration form (see page 5-26). The most recent GPS position obtained by Asset Surveyor will be stored as the initial position, and will be used when Asset Surveyor next starts communicating with a GPS receiver. If you travel a considerable distance (200 km or more) between GPS sessions, you might wish to enter a new initial position, in order to ensure a rapid GPS startup in your new location. The initial position need only be approximate, so even a position in the right State is better than nothing.

If you have traveled a considerable distance since last using GPS, and don't have any idea of your approximate position, do not worry. Your Trimble GPS receiver will still be able to initialize itself and acquire satellites, but may take up to 15 minutes to do so.



Note – A reasonable initial position should be entered **before** the GPS receiver is activated. Once the almanac, time and initial position have been sent to the receiver, it immediately starts searching for satellites on the basis of that information.

GPS/ Operations

The Asset Surveyor software acts as a control panel for your Trimble GPS receiver. Some receivers are even switched on and off by Asset Surveyor. The GPS receiver is controlled primarily by the way it is configured (see Chapter 5, Configuring the Asset Surveyor Software).

Apart from the GPS status line, which will be visible whenever a GPS receiver is active and communicating with Asset Surveyor, your interaction with the GPS receiver will take place through the *GPS operations* menu, described below.

The GPS Operations Menu

When the Asset Surveyor software and a GPS receiver have established communications, you can press **[GPS]** to pop up the *GPS operations* menu:

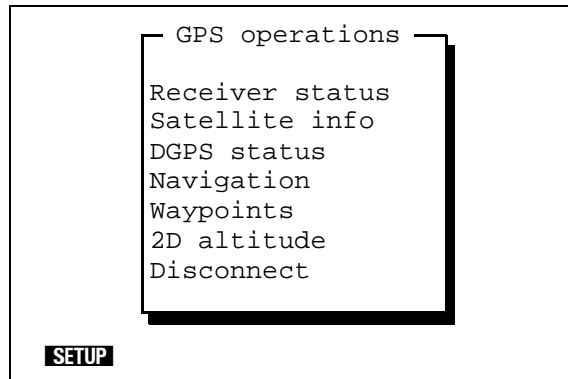

Note – The *DGPS status* option in the *GPS Operations* menu will only appear if you are connected to either a Pro XR or a Pro XRS receiver.

Each of the entries in the *GPS operations* menu is described in the following section.

Configuring GPS

The **SETUP** softkey on the *GPS operations* menu lets you conveniently configure your GPS receiver. It leads to the *Rover options* and *Base stn options* configuration forms described in *Rover Options*, page 5-3 and *Base Station Options*, page 5-51, respectively.

GPS/ Operations/ Position

If you select the *Position* entry from the *GPS operations* menu, Asset Surveyor will display the current GPS position, if available, or the most recent GPS position, if none is currently available.

Position	
Lat:	43°31'12.134"
Lon:	172°36'59.202"
Alt (MSL):	55.00m
Datum:	WGS 1984
Zone:	N/A

WAYPT

When Asset Surveyor is unable to obtain a current GPS position from the GPS receiver (e.g. due to a high PDOP value, or insufficient satellites), the title of this form changes to *OLD position*, which will flash on and off.

If you have selected a local coordinate system, the GPS position form might look more like:

If you are using *Over and Up* mode, the GPS position form will display paper units, and might look like:

Position	
Left:	5.6cm
Up:	12.4cm
Alt (MSL):	74.17m
Datum:	NAD-83
Zone:	Over and Up
WAYPT	

When current GPS positions are available, Asset Surveyor updates the contents of the GPS position form every 1–2 seconds. This is independent of the interval at which GPS positions might be logged to a data file.



Tip – You cannot edit any of the fields in the GPS position form; it is for viewing only. If you wish to change your coordinate system, press **Config** and select *Coordinate system* from the *Configuration* menu. If you wish to change your altitude reference from mean sea level (MSL) to height above ellipsoid (HAE), or vice versa, select *Units and display* from the *Configuration* menu. The order of the *Lat/Long* or *North/East* fields can also be configured under *Units and display*, as can the units in which *North/East* coordinates are displayed (see page 5-75 and page 5-79).

You can press the **WAYPT** softkey to save the current GPS position (or an old one, if no current one is available) as a waypoint. For details of creating a new waypoint see page 7-56.



Note – The GPS *Position* form takes the currently configured antenna details into account, and subtracts the height of the GPS antenna from the GPS positions supplied by your receiver before displaying them. The displayed positions apply therefore to the ground beneath the antenna, rather than to the Antenna Phase Center itself.

GPS/ Operations/ Receiver Status

If you select the *Receiver status* entry from the *GPS operations* menu, Asset Surveyor will display information regarding the status of the connected GPS receiver:

Receiver status	
Mode:	Manual 3D
SVs:	12,13,22,29,31
PDOP 3.6	HDOP 1.8
VDOP 3.1	
Receiving RTCM:	Yes
Receiver info	
Receiver:	4000SE
Nav version:	5.60
Sig version:	1.24
Battery:	12%
Status:	Doing fixes

The contents of the *Receiver info* section of the form describes the actual GPS receiver which is currently connected. The example above illustrates status for a Series 4000 receiver, while the example below shows status for a Pro XRS receiver:

Receiver status	
Mode:	Manual 3D
SVs:	4,6,22,25,15
PDOP 2.1	HDOP 1.6
VDOP 1.3	TDOP 0.3
Receiving RTCM:	Yes
Carrier time:	0:00:00
Receiver info	
Receiver:	Pro XRS
Nav version:	78.04
Sig version:	253.10
Battery:	12.3V
Status:	Doing fixes
User access:	Enabled
Landstar ID:	5001
Omnistar ID:	34000

The various fields of the *Receiver status* form are described in the following sections. Their values will be updated periodically to ensure that they accurately portray the status of the GPS receiver.

You can press  at any time to exit the *Receiver status* form and return to the *GPS operations* menu.

Mode

The *Mode* field shows the receiver's current position mode. This will remain constant if you have selected *Manual 2D*, *Manual 3D* or *Overdet. 3D* or may vary if you have configured your GPS receiver to use the *Auto 2D/3D* position mode, depending on the number of available satellites.

When the mode value ends in '2D', the GPS receiver will compute two dimensional positions, and when it ends in '3D' the GPS receiver will compute three dimensional positions.

SVs

The *SVs* field lists the satellites which are currently being used to compute positions. The abbreviation 'SV' refers to 'space vehicles', the official term for the physical GPS satellites. The numbers listed are the PRNs (Pseudo-Random Numbers) of the satellites. Satellite PRNs are described in the glossary to this manual, and in the *Mapping Systems General Reference*.



Note – The number of satellite PRNs in this list is the number which appears in front of the '/' character at the left-hand side of the GPS status line (i.e. the number *n* in 'SV *n/m*').

PDOP, HDOP, VDOP and TDOP

These four dilution of precision (DOP) values are shown on the next two lines of the *Receiver status* form.

The PDOP (position dilution of precision) value is a measure of positional accuracy, and PDOP values can generally be categorized by Table 6-1.

Table 6-1 PDOP Value Categories

PDOP level	Quality
1 to 4	Excellent
4 to 6	Good
6 to 8	Fair
8 to 12	Poor
12 and above	Unusable

The PDOP value also appears in the center of the GPS status line.

The VDOP (vertical dilution of precision) value is a measure of vertical accuracy; HDOP (horizontal dilution of precision) is a measure of horizontal accuracy. PDOP is a combination of VDOP and HDOP.

The TDOP (time dilution of precision) value is a measure of the accuracy of the GPS receiver's internal clock and those in the GPS satellites.



Note – When connected to a Series 4000 GPS receiver, the TDOP value will not be shown, as the Series 4000 receiver does not make a TDOP value available to Asset Surveyor. Also, whenever the current PDOP value is above the PDOP mask, the Series 4000 receiver ceases to supply up-to-date HDOP or VDOP values, which will then be shown as 0.0 by Asset Surveyor.

Refer to the *Mapping Systems General Reference* manual for a more detailed discussion of DOP values and their significance.

Receiving RTCM

The value of the *Receiving RTCM* field indicates whether or not the GPS receiver is currently using RTCM input (from a telemetry link) to differentially correct positions in real time. When RTCM is being received, the '#' character on the GPS status line will change to an 'R'.

Carrier time

The *Carrier time* field shows the time in hours, minutes and seconds since the last time the receiver lost lock on the required number of satellites to provide accurate carrier phase information. The *Carrier time* field will reset to 00:00 if the number of satellites used by the receiver drops below four.



Note – The number of satellites locked onto for carrier phase data may differ from the number of satellites used by the receiver to compute positions using code-phase GPS information.

If the *Carrier time* field resets to 00:00, the features you have captured may not achieve the desired precision. Refer to Appendix F in the *TDC2 Asset Surveyor Operation Manual* for further instructions on collect in carrier phase data.



Note – When connected to a receiver that does not support carrier phase data, the *Carrier time* field will not be shown. The Series 4000 GPS receiver does not support carrier phase logging with Asset Surveyor.

The *Carrier time* field will display N/A if you are attached to a receiver that supports carrier phase, but you are collecting only code-phase positions.

Receiver Info

The *Receiver Info* section contains a number of fields describing the currently connected GPS receiver:

- The *Receiver* field, shows the name of the GPS receiver. For example, 4000SE, ProXL. Do not be disconcerted if the name shown here does not precisely match the name which you might use to refer to the receiver. Asset Surveyor shows the receiver's internal name.
- The *Nav version* shows the GPS receiver's navigation firmware version number. If you call a Trimble Assistance Center, you will probably be asked for the navigation firmware version of your GPS receiver, as this can often assist Trimble's support staff to diagnose and fix a problem.
- The *Sig version* field shows the GPS receiver's signal processor firmware version number.
- The *Battery* field shows the current level of charge in the GPS receiver's battery, if available. This value may appear as a voltage, a percentage, or as a discrete value such as Good or Low, depending on the connected GPS receiver.
- The *Status* field shows the current status of the GPS receiver. This field can take one of the following values:
 - *No GPS time*. The GPS receiver has not yet acquired a signal from one GPS satellite, and has therefore not acquired accurate GPS time.
 - *PDOP too high*. The current PDOP value is in excess of the PDOP mask, and consequently the GPS receiver will not compute GPS positions.

- *No usable satellites.* The GPS receiver is unable to find any usable (both visible and healthy) satellites, or has lost signals from all satellites (perhaps due to an obstruction).
- *Too few SVs.* The GPS receiver has acquired satellites, but too few to compute a position in the current position mode (i.e. less than three satellites in a 2D mode, less than four satellites in Manual 3D mode, or less than five satellites in Overdetermined 3D mode).
- *Satellite unusable.* The GPS receiver has just rejected a particular satellite, probably because it has become unhealthy.
- *Doing fixes.* The receiver is computing GPS position fixes. The current satellite constellation is therefore acceptable.
- *User Access.* This field shows whether the LandStar or OmniSTAR DGPS satellite correction service has been enabled for the Pro XRS receiver. If the receiver has not been activated for DGPS satellite corrections, this field will display unknown.
- *Landstar ID.* This field shows the LandStar activation code. You will need this code when contacting your LandStar provider for activation.
- *Omnistar ID.* This field shows the OmniSTAR activation code. You will need this code when contacting your OmniSTAR provider for activation.



Note – The *User Access*, *Landstar ID* and *Omnistar ID* fields are displayed only when connected to a Pro XRS receiver.



Note – For further details on activating the satellite DGPS component of your Pro XRS receiver refer to the *Pro XR/XRS Receiver manual*.

GPS/ Operations/ Satellite Information

If you select the *Satellite info* entry from the *GPS operations* menu, Asset Surveyor will display information for each satellite in the GPS receiver's tracking set:

PRN	SNR	Ele	Br(T)	URA
✓14	21	51°	312°	32
18	0.0	25°	236°	–
25	3.6	23°	112°	32
✓29	7.1	67°	229°	4.0
✓03	8.6	68°	77°	2.8
SV 3/4 PDOP 6.2 #				

This form displays five columns of information, and spans as many pages as required to display information for all satellites in the receiver's current tracking set. The columns are:

- **PRN.** Each satellite's PRN is listed to identify that satellite uniquely. If the satellite is currently being used by the GPS receiver to compute positions, then a tick (✓) character appears to the left of the PRN. In the example above, satellites 14, 29 and 3 are being used to compute positions.
- **SNR.** The current signal-to-noise ratio of each satellite is indicated in the SNR column. The number of satellites with a non-zero SNR is the number to the right of the '/' in the GPS status line (i.e. the number *m* in 'SV *n/m*'). These are the satellites which the GPS receiver could use for computing positions. A given satellite may not be used for a number of reasons, including:
 - The satellite's SNR is beneath the configured SNR mask.
 - Using this satellite to compute positions would increase the PDOP value, possibly to the point where it would exceed the PDOP mask.

- The satellite's elevation is beneath the configured elevation mask.

If a satellite has been marked as 'unhealthy' by the GPS Control Segment, the characters 'U/H' will appear in the SNR column for that satellite. The GPS receiver will not attempt to use unhealthy satellites for computing positions.

- *Ele.* This column shows the current elevation of each satellite above the horizon. Typically, satellites which are far below the configured elevation mask are dropped from the receiver's tracking set, so that the receiver can concentrate on satellites which are currently visible.
- *Br(T).* This column, which can be labeled either 'Br(T)' or 'Br(M)', shows the current bearing to each satellite in the tracking set. This bearing is shown relative to either true north (T) or magnetic north (M), as determined by the currently configured *North ref.*



Tip – You can change the value of the *North ref* field in the *Units and display* configuration form, under the *Configuration* menu.

- *URA.* This column shows the *User Range Accuracy* value for each satellite in the tracking set. URA is an estimate of the accuracy of the pseudo-range measurement to each satellite. It is based on a number of factors, including the age of the data, the type of clock in the satellite, the satellite orbit and clock behavior, and whether Selective Availability (SA) is activated for that satellite.

These values and their interpretations are shown in Table 6-2.

Table 6-2 Interpretation of URA Values

URA value	Interpretation
Below 6	Accuracy is good
6 to 15	Accuracy may be poor
16 to 30	SA may be activated
31 to 64	SA is activated
Above 64	SA is activated to an abnormal extent, or a problem exists with this satellite. (Satellite problems usually cause a satellite to be set 'unhealthy').

The contents of the *Satellite info* form will be updated every eight seconds.

You can exit this form by pressing (Esc) at any time.

GPS/ Operations/ DGPS status

If you select the *DGPS status* entry from the *GPS operations* menu, Asset Surveyor will display information regarding the status of the integrated DGPS component of the connected Pro XR or Pro XRS receiver

DGPS status	
DGPS mode:	Beacon
Status:	Lock
Frequency:	314.0 kHz
Error rate:	0.000
SNR:	23.9 dB
Input level:	66.5
Data rate:	100 b/s
Health:	Healthy
SETUP	



Note – This option is only available if the connected receiver is a Pro XR or Pro XRS receiver. If any other receiver is connected, the *DGPS status* option will not appear in the *GPS operations* menu.

The status information displayed in the form will depend upon which source of real-time corrections is being used. The screen above shows the *DGPS status* form when the source of real-time is a beacon.

The following screen shows the form when the source of real-time corrections are received from a DGPS.

DGPS status	
DGPS mode:	Satellite
Status:	Lock
Frequency:	1556.255 MHz
Last RTCM:	0.000
SNR:	240.0dB
Input level:	50.0
Data rate:	1200 b/s
SETUP	

The various fields of the *DGPS status* form are described in the following sections. Their values are updated periodically to ensure that they accurately portray the status of the DGPS component of the Pro XR or Pro XRS receiver. You can press (Esc) at any time to exit the *DGPS status* form and return to the *GPS operations* menu.

DGPS mode

The *DGPS mode* field shows the current source of DGPS corrections used by the Pro XR and Pro XRS receivers. The possible values for this field are *Beacon* or *Satellite*.

When connected to a Pro XR only the *Beacon* mode is available.

Status

The *Status* field shows the current operating DGPS status of the Pro XR and Pro XRS receivers. The possible modes of operation for this field are:

- *Idle*. The DGPS component of the receiver has just powered on, or you have changed the *Mode* to another setting in the *Integrated DGPS* form.
- *Disabled*. The DGPS component of the receiver has been turned off in the *Integrated DGPS* form.

- *Search.* The DGPS component of the receiver is currently searching the frequency range for a usable DGPS signal.
- *Track.* The DGPS component of the receiver has detected a usable DGPS signal, but no corrections are being received.
- *Lock.* The DGPS component of the receiver has detected a usable DGPS signal, and is receiving corrections to compute real-time positions.

Frequency

This field displays the current frequency being tracked/locked onto. The available frequencies are between 283.5 kHz and 325 kHz for the beacon. A available frequencies for the integrated satellite DGPS receiver are between 1525 MHz and 1559 MHz.

Error rate

This field shows the RTCM Word Error Rate. This is the number of RTCM words with parity errors, expressed as a decimal fraction. An error rate below 0.1 is acceptable. This field is applicable only when using beacon corrections.

Last RTCM

The *Last RTCM* field appears only when using the integrated satellite DGPS component of the Pro XRS receiver. This field indicates the time, in amounts of 0.1 seconds, since the last RTCM message for a DGPS satellite was received by the integrated DGPS receiver component of the Pro XRS.

SNR

The signal-to-noise ratio, measured in decibels (dB), at the beacon or satellite DGPS frequency. An SNR above 6.0 dB for the beacon frequency indicates that the signal is usable. An SNR above 3.0dB for the Satellite DGPS frequency indicates that the signal is usable.

Input level

This field displays the intensity level of the electro-magnetic field, measured in decibels above one microvolt per meter (dB μ V/M). An input level above 10 dB μ V/M is acceptable.

Data Rate

This field identifies the data modulation rates from the integrated real-time component (Beacon or Satellite) currently being used by the Pro XR or Pro XRS receivers.

Health

This field shows whether the signal received from the integrated beacon component currently being used is *Healthy*, *Unhealthy*, or *Unmonitored*. This field does not display when receiving corrections from the satellite DGPS component of the Pro XRS receiver.

GPS/ Operations/ Navigation

You can use any supported Trimble GPS receiver for navigating. Together with Asset Surveyor you can use GPS to navigate to prerecorded waypoints, features, or coordinates entered from maps or databases.

Navigation with the Asset Surveyor software is described on page 7-42.

GPS/ Operations/ Waypoints

A waypoint is a named 3-dimensional position, which you can record using GPS or enter from a map, for the purposes of navigating (back) to that point in the future.

Asset Surveyor's waypoint management facilities are described in detail on page 7-54.

GPS/ Operations/ 2D Altitude

When you operate a GPS receiver in either *Auto 2D/3D* or *Manual 2D* position mode, Asset Surveyor will ask you to provide a 2D altitude before it activates the GPS receiver. When operating in one of these modes, you can view the current 2D altitude or enter another by selecting 2D altitude from the *GPS operations* menu.

2D altitude	
Alt (MSL):	
Entered at	
Time:	11:15:23 am
Date:	08/22/1995 Tue

You can press **(Esc)** to continue with the previous 2D altitude, or you can enter a new altitude and press **(OK)** to send that new altitude to the GPS receiver.

Only the first field on this form is editable. The other fields show when the last 2D altitude was recorded, and whether it was entered manually (*Entered at*) or computed by the GPS receiver (*Computed at*).

The 2D altitude which is sent to the receiver will be converted to an altitude above or below the WGS-84 datum. The value which you enter will be relative either to mean sea level (MSL) or the local ellipsoid (HAE).



Caution – You must ensure that any 2D altitude which you enter is accurate, otherwise it will have a detrimental effect on the accuracy of positions computed by your GPS receiver when operating in a 2D mode.



Tip – You can change the value of the *Altitude ref* field in the *Units and display* configuration form, accessible from the *Configuration* menu.



Note – The altitude you specify is that of the ground, not the altitude to the GPS receiver's antenna. Asset Surveyor will take the currently configured antenna height into account when converting the altitude you supply into an altitude above the WGS-84 datum.

GPS/ Operations/ Disconnect

When you select *Disconnect* from the *GPS operations menu*, Asset Surveyor will cease communications with the GPS receiver and will shut down all GPS logging operations, etc. Before doing so, it will ask you to confirm that you have not selected this option by mistake:

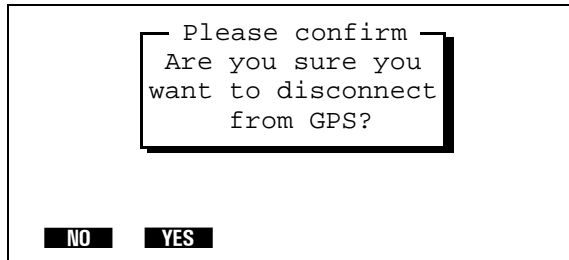

If you press **YES**, the GPS receiver will be turned off, if possible, and Asset Surveyor will close down its GPS operations.

Normally, you will have no need to *Disconnect* (deactivate) the GPS receiver; you can just turn the TDC2 off when you finish using it. If you wish to use the Asset Surveyor software for a while without needing GPS and wish to preserve the GPS receiver's batteries, you may choose to deactivate the receiver. You must physically disconnect the receiver before transferring files to or from the PC, as Asset Surveyor uses the same serial port for these operations as it uses to communicate with the GPS receiver.



Tip – To re-activate the GPS receiver, press **GPS**.



Note – When Asset Surveyor deactivates and turns off a Series 4000 GPS receiver, it will not be able to turn the receiver back on remotely. You will have to turn the Series 4000 receiver on by pressing the POWER button on the receiver's front panel, before Asset Surveyor can re-establish communications with the receiver.

7 The Main Menu

The heart of the Asset Surveyor system is its *Main menu*:

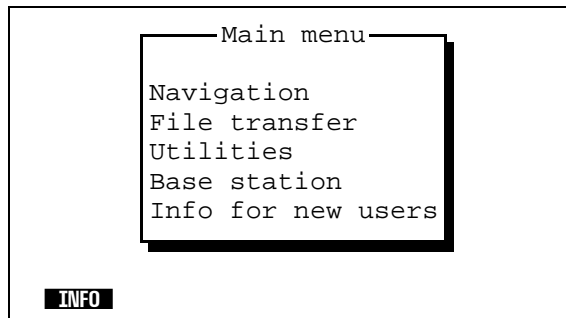

Although you will spend very little time at the *Main menu*, you will occasionally return here to switch between major operations such as data capture and file transfer.

When the Asset Surveyor software is first started, it will display the *Main menu* and await your choice of operation. You can generally return to the *Main menu* from wherever you are in the system by pressing (Esc) several times (possibly answering questions along the way).

The following sections describe each entry in the *Main menu* in detail.

Main Menu/ Data Capture

If you select *Data capture* from the *Main menu*, Asset Surveyor displays the data file management menu:

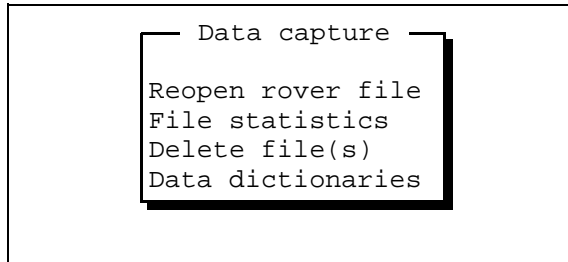

The following sections describe in detail each operation which can be performed from this menu.

Main Menu/ Data Capture/ Creating Rover Files

When you select *Create rover file*, Asset Surveyor will display the *Create file* form:

Create file	
File:	
Data dict:	Generic
Carrier mode:	Off
Free space:	490kB
TIME	

Asset Surveyor suggests a default file name, as described in File Naming Conventions, page 4-32. The default name appears in the *File* field. You can accept this default name, edit it, or enter a new name altogether. File names can be at most eight characters long, and can be composed of letters and digits only (i.e. no spaces or punctuation characters).

After accepting the default file name or entering a new one, you can select a data dictionary from the menu of data dictionaries which have been loaded onto your TDC2. The default *Data dict* is the data dictionary which was most recently used to create a data file. There is always a Generic data dictionary available, which lets you record point, line and area features, each with a simple description attribute.



Note – The data dictionary you choose when you create a data file will be associated with that file for the duration of its 'life'. The data dictionary determines the types of features which can be recorded to this file, as well as the attributes these features will have.

The third field of the *Create file* form lets you choose whether to log carrier phase data or not. By default, *Carrier mode* is set to Off.



Note – If you are connected to a GPS receiver that does not allow carrier phase data collection with Asset Surveyor, the *Carrier mode* field will not be displayed.

The last field of the form, *Free space*, reminds you how much data file storage space remains on your TDC2. You cannot edit this field.

You can use the **TIME** softkey to switch between UTC and local time for the default file name, as described on page 4-26.

Once you have accepted a file name and data dictionary and chosen whether or not to record carrier phase data, press **OK** to create the new data file. Asset Surveyor will check to see that the file's name is unique before creating the file. If it is not (i.e. a file with that name already exists), Asset Surveyor displays the following message:

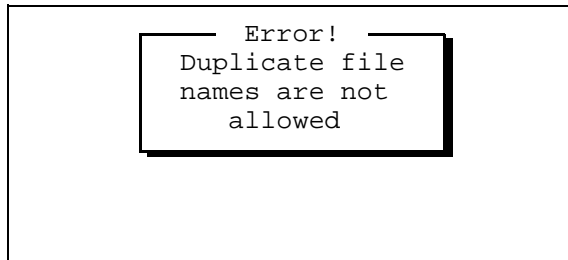

You will have to think of another name for your new file, or if you are happy to append to the existing file with the same name then you can exit the *Create file* form by pressing **(Esc)** and just select the file with that name from the *Reopen rover file* menu.



Note – The data dictionary associated with the existing file will be the data dictionary which was selected when that file was created. It will not necessarily be the data dictionary which you selected when attempting to create a data file with the same name.



Note – Once the file has been created, the *Carrier mode* cannot be altered from this point.

If there is insufficient data space to create a new file, or if Asset Surveyor cannot create the new file for some other reason, the program will display a message and then reboot the TDC2. If the problem is simply one of insufficient space, you should transfer some or all data files to your PC, then delete them from the TDC2 before attempting to create any new data files.

When you create a new rover file and press , Asset Surveyor will automatically open the newly created file, ready to log data to it.

Main Menu/ Data Capture/ Reopening Rover Files

You can reopen an existing data file by selecting *Reopen rover file* from the *Data capture* menu and selecting from the list of available rover files:

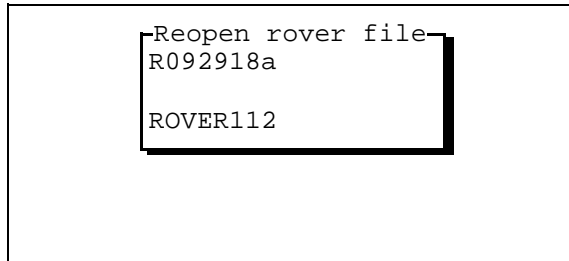

If a data file was created more than seven days ago, Asset Surveyor will not let you reopen that file for further logging of data (although you will be allowed to review and edit it). This is due to a technical limitation related to the way in which GPS times are stored. In order to maintain full accuracy of storage, it is necessary to limit the time-span of a data file to seven days. If Asset Surveyor displays the following message:

then you should create a new data file and capture data to that instead.

Main Menu/ Data Capture/ Data File Statistics

If you select *File statistics* from the *Data capture* menu, Asset Surveyor will display a list of existing rover and base files:

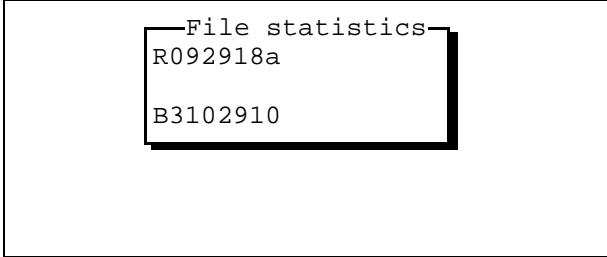

The screenshot shows a menu titled "File statistics" with a list of two files: "R092918a" and "B3102910". The menu is displayed within a rectangular frame.

To view statistics for a particular data file, select it from this list:

This form provides a variety of interesting statistics about the data file:

- The *File* field shows the data file's name.
- The *Data dict* field shows the name of the data dictionary which is associated with this data file.
- The *No. of features* field shows the number of point, line and area features in the data file.
- The *File size* field shows the size of this data file in kilobytes.

- The *Free space* field shows the remaining amount of data space, in kilobytes, on the TDC2.
- The *File start* fields show the time and date when this file was created. This is not the same as the time when the file first had data logged to it, but these two events normally occur one after the other.
- The *File end* fields show the time and date when this file last had data logged to it.



Note – If you select *File statistics* when there are no data files in the TDC2's memory, the *File statistics* form will be immediately displayed with only the *Free space* field visible.

Main Menu/ Data Capture/ Deleting Data Files

If you select *Delete file(s)* from the *Data capture* menu, Asset Surveyor displays a menu of rover and base files:

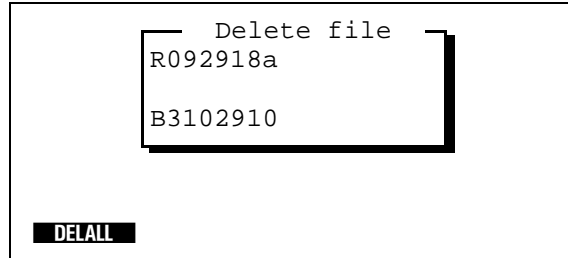

To delete a single data file, select it from the *Delete file* menu by highlighting the file's name and pressing . To delete all data files at once, press **DELALL**.

When you select a single data file to delete, Asset Surveyor will ask you to confirm that you wish to delete the file:

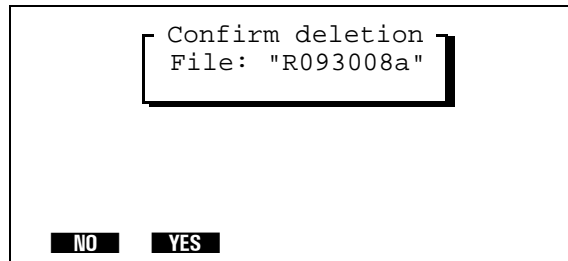

When you press **DELALL**, Asset Surveyor will beep and ask you to confirm that you wish to delete all data files:

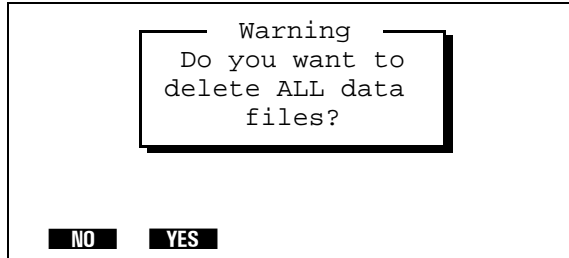

For each data file which it is about to delete, Asset Surveyor will check whether the file has been transferred to your PC. If it has not yet been transferred, Asset Surveyor warns you of that fact and asks you confirm once more that you wish to delete it:

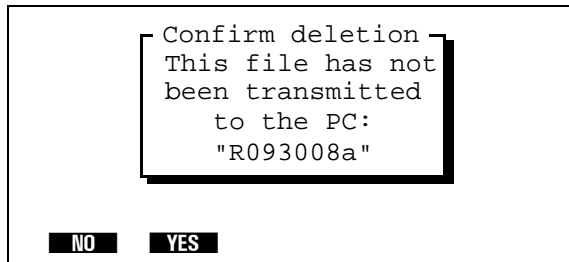

If you press **YES** to this question, or if the file had previously been transmitted to your PC, Asset Surveyor will delete the data file and recover the space which had been consumed by it.

Main Menu/ Data Capture/ Data Dictionaries

If you select *Data dictionaries* from the *Data capture* menu, Asset Surveyor will display a menu of data dictionaries:

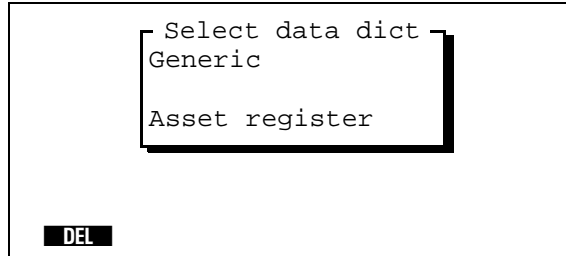

The currently highlighted data dictionary is that which was used when you last created a data file. If you select a different data dictionary from this menu, the new data dictionary will become the current data dictionary, and will be offered as the default when you next create a data file.

The Asset Surveyor software lets you have a number of data dictionaries available for performing different kinds of surveys. You can maintain two or more current data files, with possibly different associated data dictionaries, and can swap between them very easily.

You can press the **DEL** softkey to delete the currently highlighted data dictionary from the TDC2. If you attempt to delete a data dictionary which is still associated with a data file on the TDC2, Asset Surveyor will refuse to delete that dictionary:

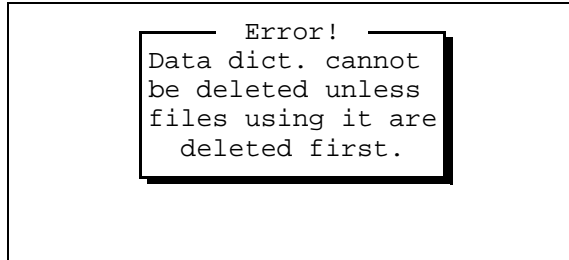

You must delete all data files associated with a data dictionary before you can delete the data dictionary itself.



Note – You cannot delete the *Generic* data dictionary, which is always available in Asset Surveyor. This is the data dictionary associated with base station data files, and it can also be used for creating rover files for off-the-cuff data capture.

Select a new data dictionary from the menu or press **Esc** to return to the *Data capture* menu.

Main Menu/ Data Capture/ Starting to Log Data

When you create a new data file or reopen an existing one, Asset Surveyor will prepare to log data to that file, as described in this section.

When a data file is opened, Asset Surveyor will spend a few seconds writing initial data to the file, and reading its associated data dictionary, before displaying a menu of features (as determined by the data dictionary) which can be captured to this file.

If you open a data file and have previously configured the *Confirm* field in the Antenna options to 'per field' or 'per feature', Asset Surveyor will pop up the *Antenna options* form:

Antenna options	
Height:	
Measure:	Vertical
Type:	EC
Confirm:	Per feature

You should verify that the configured antenna height and type are correct before pressing to proceed to capture data to this file. See Table 5-1, page 5-41 for a list of antenna types.



Tip – Remember that you should enter a new antenna height, via the **ANTENNA** softkey in the GPS *Rover options* configuration form, whenever you alter the height of your GPS antenna.



Note – When a data file is opened, Asset Surveyor will activate any external sensor or laser rangefinder interfaces which have been configured to automatically connect.

If you have configured Asset Surveyor to capture carrier phase data, the following message will appear briefly on the status line to confirm that carrier phase logging is on.

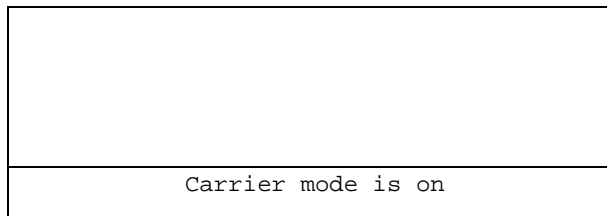

If you have configured the file not to capture carrier phase information then the following message will display when you open the file.

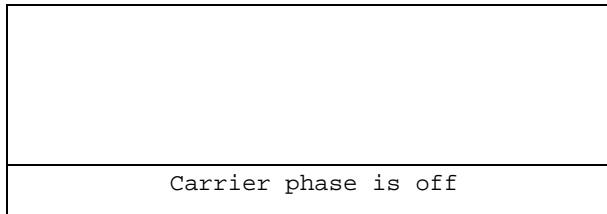

Main Menu/ Data Capture/ Logging Notes

When logging to a data file commences, Asset Surveyor writes a note to the data file recording the time and date. For example:

```
Review note  
  
09:16:20 am  
09/30/1993 Thu  
(Local time)
```

When you exit data capture and logging to that data file stops, Asset Surveyor writes another note. For example:

Main Menu/ Data Capture/ Starting Features

The menu of available features might look as follows:

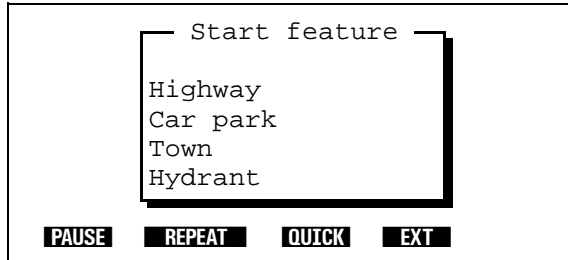

You can choose a feature to capture by selecting it from the menu. You can also perform a number of other operations using the four softkeys.



Note – Features are captured one at a time; you normally end a feature before starting the next. A useful exception to this rule is the embedding of point features within line or area features using the quickmarking (see page 7-26) and nesting (see page 7-30) techniques.

Selection of a Feature to Capture

When you select a feature from the menu above, Asset Surveyor will start to capture data for the feature. A feature's data includes:

- Its GPS position(s),
- An optional offset to the GPS position(s),
- Its attributes, which can be entered using the TDC2's keypad or using a barcode wand, and
- Any external sensor data which might be recorded for that feature.

Provided a GPS receiver is connected and operational, Asset Surveyor will record GPS positions automatically for the feature, according to the way in which you have configured the GPS interface. If you have configured and activated an external sensor, ESP data will also be recorded automatically. If you have configured and activated a laser rangefinder, you can record an offset for the feature by aiming and firing the rangefinder. Alternatively, you can measure and enter the offset manually.

By taking care of GPS and ESP data capture, and by integrating the recording of an optional offset to each feature, the Asset Surveyor software enables you to concentrate on entering attribute values for the feature.



Note – If you have selected 'per feature' for the *Confirm* field in the *Antenna options* form, the *Antenna options* form will be displayed prior to the collection of each feature.

The attributes describing each feature are determined when you create your data dictionary using Pathfinder Office. The following diagrams illustrate attributes for three of the features in the menu shown above. They are a point feature:





<<Town>>	
Name:	
Population:	?
Gas stations:	?
Any open 24 Hrs?:	No
Banks:	?
PAUSE EXT OFFSET	

a line feature:



<<Highway>>	
Name :	
Number :	?
Interstate? :	No
Lanes :	6
PAUSE NEST SEG QUICK EXT OFFSET	

and an area feature:

Main Menu/ Data Capture/ Entering Attribute Values

The attribute entry form for a feature behaves identically to other Asset Surveyor forms. You enter values for each field, according to its type (menu, numeric, character string, time or date), and move from field to field using , , ,  and  keys.

You can also enter attribute values (for menu attributes) using a barcode wand.

When you have finished entering attribute values, press  to save the feature. You can press  to abandon the feature without saving it, but Asset Surveyor will always ask you to confirm this:

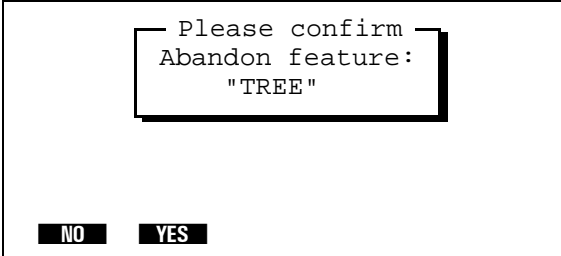

```

Please confirm
Abandon feature:
"TREE"

NO YES

```



Caution – When you abandon a feature, Asset Surveyor will discard not only the partially entered attribute values but also any GPS positions and/or ESP data records which have been recorded for that feature. The only exception to this rule is a line or area feature, in which case the GPS positions are not discarded, but are treated as not-in-feature positions. These provide a trail showing the path which you traveled.

Main Menu/ Data Capture/ Saving Features

As with a normal Asset Surveyor form, you can press to save the attribute entry form's contents, but you will probably not press the moment you finish entering attributes for the feature. This is because, while the feature is 'active', any GPS positions and ESP data which are logged will be associated with that feature. If this is a point feature, you should remain stationary at that feature until the configured minimum number of positions have been logged before pressing . If it is a line or area feature you should continue to walk or drive along the feature (or around its perimeter, if it is an area feature). Only when you have traversed it completely should you press .



Tip – Because, when traversing a line or area feature, you can often pass points of interest, Asset Surveyor allows a number of convenient ways to capture point features *within* a line or area feature. These are discussed under the titles of *Quickmarking Point Features* and *Nesting Point Features*, on page 7-26 and page 7-30, respectively.

If you are capturing a point feature and press before the configured *Minimum posns* have been logged, Asset Surveyor will warn you:

```

Please confirm
Insufficient GPS
positions; do you
want to store this
feature now?
NO YES

```

Press to store the point feature with fewer than *Minimum posns* GPS positions, or press to return to the feature and wait for more positions to be logged.

If you are logging carrier phase data and attempt to close a file before the *Minimum time* carrier phase field has been exceeded, and you have logged a position during that time, Asset Surveyor will prompt you to confirm that you do wish to close the file:

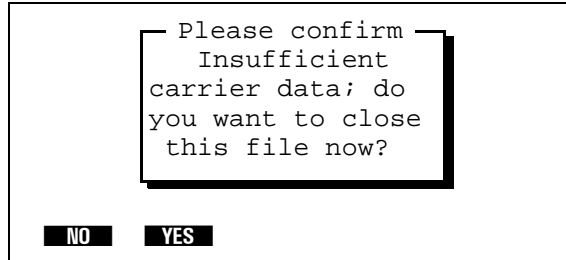

Press **YES** to close the file now, or press **NO** to leave the file open and wait for further carrier phase data to be logged.

The various other operations which can be performed, by pressing softkeys during the capture of features and/or the entry of attributes, are described in the following sections.

Main Menu/ Data Capture/ Pause and Resume Logging

When you are entering attributes for a feature or are at the *Start feature* menu, Asset Surveyor provides a **PAUSE** softkey. When you press **PAUSE**, Asset Surveyor will cease to log GPS positions. While logging is paused, the message:

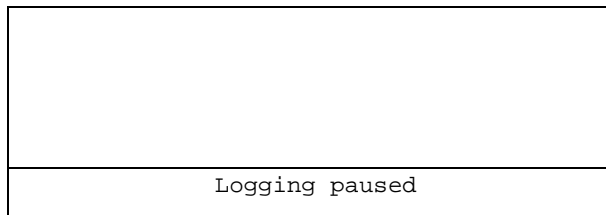

will be displayed periodically on the GPS status line, and the **PAUSE** softkey will change to **RESUME**. When you press **RESUME**, Asset Surveyor will resume logging and the softkey will revert back to **PAUSE**.



Note – Pausing logging will not pause the logging of carrier phase data.



Tip – Press **PAUSE** whenever you want to stop briefly, or if you are capturing a line or area feature and have to travel around some obstacle before picking up the line or area perimeter again. You should also use **PAUSE** if you want to *nest* a point feature within a line or area, and the point lies some way off the line or area perimeter. You can then nest the point without ending up with a 'spike' in the line or area.

When GPS logging is paused, Asset Surveyor will not record GPS positions, velocities or raw GPS measurements, but it will continue to record certain critical GPS information which is required for postprocessing. This additional information is quite small, and will be recorded infrequently, but it is possible that even when logging is paused your TDC2 may eventually run out of data storage space.

Each time you resume logging while capturing a line or area feature, Asset Surveyor will log a GPS position (irrespective of the logging interval for line/area features).



Tip – You can use this feature to explicitly force Asset Surveyor to log a GPS position when you come to a corner or a point of interest while capturing a line or area feature. Press **PAUSE** and then **RESUME** to cause the current GPS position to be logged. After **RESUME** is pressed, Asset Surveyor will continue to log GPS positions at the configured line/area logging interval.

Main Menu/ Data Capture/ Repeating Features

Usually, you select a feature to capture using normal menu selection techniques (i.e. highlighting a feature and pressing , or using a first-letter selection method). You can also select the currently highlighted feature on the *Start feature* menu by pressing **REPEAT**.

The difference between normal selection of a feature and selecting using **REPEAT** lies in the default attribute values given to the feature. If you select the feature by the 'normal' method, the default attribute values are determined by the data dictionary, which specifies a default value for each attribute belonging to each feature. If you select a feature using **REPEAT**, the attribute values will be copied from the last recorded feature of that type.



Tip – **REPEAT** enables you to record a sequence of similar features very efficiently. You don't have to re-enter the values for all of the attributes, but can just page through checking that each attribute value is correct for the current feature, and change only those that differ.

If you press **REPEAT** and a feature of the currently highlighted type has not yet been recorded to the current data file, Asset Surveyor will inform you that it cannot repeat this feature type:

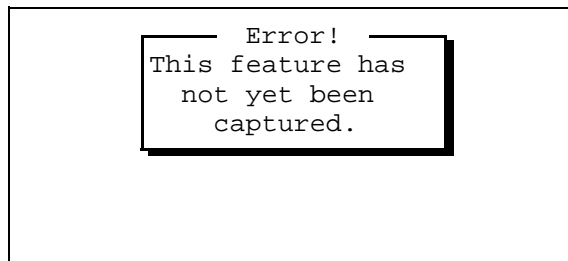

You must first capture a feature using the normal method before you can **REPEAT** it.



Note – Offsets, except those configured as constant offsets, will not be repeated when the **REPEAT** softkey is pressed.

Main Menu/ Data Capture/ Quickmarking

The Asset Surveyor software provides two ways to capture the GPS position of a point feature. The regular way is to select a point feature from the *Start feature* or *Nest feature* menus, and to stay at that feature for long enough to log sufficient GPS positions or carrier phase measurements. Another way is to record a quickmark.

A quickmark is recorded by simply pressing a button on the TDC2 as you drive, fly or move past a feature. With quickmarks, Asset Surveyor cannot record a number of positions to average together, and in fact cannot necessarily even record a single GPS position at exactly the moment that you pass the feature. It therefore records an accurate time (using the very precise GPS satellite timers to keep the TDC2's clock perfectly synchronized), which is used to compute an interpolated position for the quickmark based on two GPS positions, one logged before you passed the feature and one logged after.

The accuracy of quickmarks will not be as good as you can achieve by standing at a point and logging positions for some time, but you can use quickmarks to rapidly record reasonably accurate GPS positions for a large number of features. Quickmarking is especially useful if the features all lie along a road or path, and are a reasonable distance apart, so that even with quickmark accuracy, their interpolated positions clearly identify them.

You can record quickmarked point features when not capturing any other feature, or you can nest them within line or area features. To gain access to the quickmark recording menu, press **QUICK**. Asset Surveyor pops up a menu containing only point features:

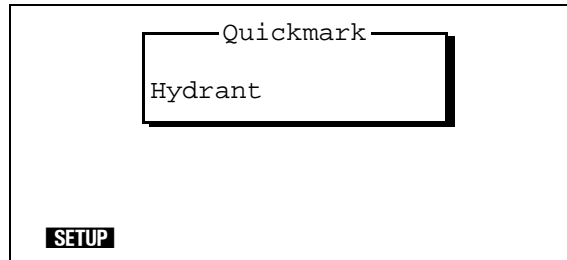

Note – You can only quickmark point features. It makes no sense to instantaneously record a single position for a line or area feature.

The **SETUP** softkey provides a short-cut to the *Quickmark* configuration form. As described on page 5-90, you can choose whether quickmarked features should be assigned default attribute values based on the data dictionary, or whether their attributes should be repeated from previous features, and you can also choose whether or not Asset Surveyor should permit you to confirm or edit the attribute values associated with each quickmark as it is recorded.

When you select a point feature from the *Quickmark* menu, Asset Surveyor records the precise time at which you selected that feature, and ensures that bracketing GPS positions will be logged for use when interpolating. It will determine the appropriate source for default attribute values (the data dictionary or a previous feature) and will log the feature's default attributes (if any).

Finally, if the *Confirm* configurable field in the *Quickmark* configuration form has been set to Yes, Asset Surveyor will automatically let you review and possibly edit these attributes. By default, the *Confirm* field's value is No, and Asset Surveyor will simply beep and display a message on the GPS status line, such as:

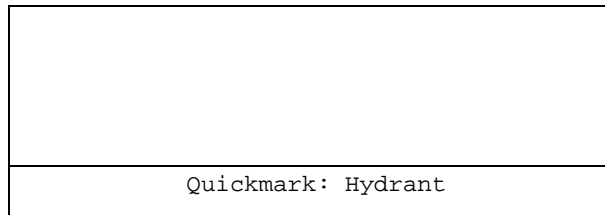

Quickmark: Hydrant

to confirm that it has recorded the quickmark.



Note – If you choose to confirm and edit attribute values for quickmarks, remember that even though it takes time to confirm or edit the attribute values, the quickmark position for the feature was recorded the instant you selected the feature. The fact that you have traveled some distance from that point by the time you press to save the edited attributes has no bearing on the feature's position.



Note – The quickmark and its attributes are saved the moment you select the feature from the menu. If you have *Confirm* set to Yes but then press on the attributes form, the feature will still have been recorded (but with unedited default values for its attributes). If you wish to delete the feature (perhaps because you selected it at the wrong moment), you must review the data file and delete it from the list of recorded features (see Chapter 8, Other Operations).



Tip – It is often not possible to drive directly over a feature, so when capturing data in a vehicle you may wish to configure a constant offset for quickmarks. You can then drive past each feature at the pre-specified distance and record offset quickmarks.

Main Menu/ Data Capture/ Nested Features

When recording a line or area feature, you will often come across point features which you would like to record. You do not have to complete the whole line or area before returning to record the point features; you can just nest the point within the line or area.

When you are capturing a line or area feature, press **NEST** to pop up a menu of point features which can be nested within that line or area feature.

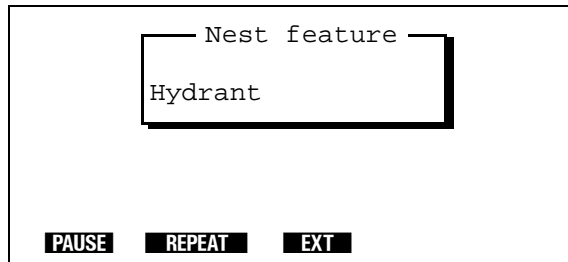

Until you actually select a point feature to nest, any GPS positions which are logged will belong to the outer line or area feature. If you wish to nest a point feature which lies off the line or area feature's perimeter, follow this procedure.

To nest a point feature outside the line or area's feature

1. Pause logging to the line or area by pressing **PAUSE**.
2. Travel to the point feature in question.
3. From the *Nest feature* menu select the appropriate point feature. (Enter height of antenna if necessary.)

When you are ready to record GPS positions for this feature, press **RESUME**. Logging will commence and continue until you save the nested feature or until you press **PAUSE** again.

4. When you have finished recording attributes for the point feature and have logged sufficient GPS positions, press **OK** to save the feature.

Asset Surveyor will automatically pause logging and will return you to the attribute entry form for the outer line or area feature. You can now press **NEST** again to nest another point feature (and repeat steps 2 to 4) or you can walk back to the line or area's perimeter and press **RESUME** to resume logging of GPS positions for the line or area.

You can nest as many point features within a line or area as you wish (limited only by storage space on the TDC2).

When you eventually complete the traversal of the line or area's perimeter, press **OK** to save that feature.



Tip – If you are traveling rapidly along a line or area's perimeter, and the points you wish to nest have few attributes, and their positions need not be quite as accurately recorded as averaged point features, you should consider quickmarking them instead of nesting them, as the recording of quickmarks is very rapid and time-efficient.

If you select a point feature to nest from the menu, it will have default attribute values as defined in the data dictionary. You can nest a point feature with the same default attributes as the previously-recorded feature of that type by highlighting the feature in the *Nest feature* menu and pressing **REPEAT**.



Note – Pausing logging will stop the logging of positions to the data file. Carrier phase data will continue to be logged (if configured)

Main Menu/ Data Capture/ Segmented Line Features

When capturing line features, it is often convenient to divide a line into a number of segments. Segmentation of lines lets you specify differing attribute values for parts of the same physical line. Segmentation also enables you to end one line feature and immediately start another (of the same type), while you are still moving. This is very useful if you are mapping roads or highways where it can be difficult or even illegal to stop at a point where one feature ends and the next feature starts.

To segment a line feature, press the **SEG** softkey. The current line feature will be saved and another line feature of the same type will be immediately started, with the same attribute values as the previous feature. The last GPS position of the first segment will be identical to the first GPS position of the second segment, so that adjacent segments will be joined end-to-end in your GIS.



Caution – When you press **SEG**, Asset Surveyor will validate the first line feature's attributes. If you have not finished entering the attributes for that line segment, Asset Surveyor will not let you save the feature. You will be required to complete attribute entry before pressing **OK** or **SEG** again to save that feature and possibly start another. In the meantime, you will have to come to a halt until the first feature has been completed.



Caution – If, when you press **SEG** and there is no current GPS position available (due, for example, to a high PDOP situation), then Asset Surveyor will **not** start the new line segment with the last GPS position of the previous line segment. Instead, the new line segment will start from the first GPS position which becomes available **after** **SEG** is pressed. Asset Surveyor may also start the new line segment at a position other than the precise end of the previous line segment if a satellite constellation change occurs at the moment **SEG** is pressed.



Caution – Segmenting when collecting carrier phase data will not force the receiver to log extra **carrier phase** information.

Main Menu/ Data Capture/ Offsets

The attribute entry forms for each type of feature include an **OFFSET** softkey. You can press this to view or enter the offset for the feature being captured. If you have configured a non-zero constant offset for the class of feature being captured, then the default offset value for that feature will be as configured.

For example, the attribute entry form for a point feature might look like:

<<Tree>>	
Type:	
Height (m):	24.5
Condition:	Poor
Age:	6
Access:	Private
PAUSE EXT OFFSET	

Pressing **OFFSET** will pop up the *Point offset* form as follows:

Point offset	
Bearing:	
Slope dist:	46.230m
Inclination:	3.4°
RESET FORMAT	

You can press the **FORMAT** softkey to toggle between the slope distance/inclination method of display and the horizontal/vertical distance method. For example:

Point offset	
Bearing:	
Horz. dist:	46.149m
Vert. dist:	2.742m
<div style="display: flex; justify-content: space-around;"> RESET FORMAT </div>	

You can change the configured constant offset for the current feature by measuring and entering a new offset, or by pressing the **RESET** softkey to indicate that there is no offset to apply to this feature.



Note – All Asset Surveyor features (be they points, lines, areas or quickmarks) can have only **one** offset associated with them. It is not possible to have two or more offsets for a single feature. In particular, this means that in order to record a line feature with a given offset and then to change the offset part-way through the line feature, it is necessary to segment the line at that point (each segmented line feature has its own offset). You must carefully plan how to capture an area feature using offsets, as the same offset value must apply to the entire area feature.

You can fill in the three offset fields for a point feature using a laser rangefinder. In the case of a line, area or quickmark feature, a laser rangefinder can only be used to fill in the last two fields; the first field (*Direction*) must always be filled in manually.



Note – When using a laser rangefinder, you do not have to visit the offset form for a point feature; simply use the laser to record the offset and watch for an 'Offset received' message on the GPS status line. For line, area and quickmark features, however, you must visit the offset form before you can record an offset using a laser rangefinder. This is because of the need for you to specify the *Direction* of the offset relative to your current direction of travel.

Main Menu/ Data Capture/ External Sensors

EXT Softkey

When capturing data to a rover file, you can press **EXT** at any time to pop up the menu of external sensors. You can activate or deactivate a sensor or laser from this menu, and once a sensor interface is active, you can check the status of a sensor, or manually initiate a reading from a sensor. You can also reconfigure a sensor from this menu if necessary.

Automatic Activation of Sensors

If you have preconfigured an external sensor interface and have set the *Auto-connect* configuration field to Yes, then Asset Surveyor will automatically attempt to activate the sensor interface when you create or reopen a rover data file.

If you have not preconfigured the sensor to automatically connect (i.e. activate), then you can manually activate it via **EXT**.

Automatic Deactivation of Sensors

If you press **EXT** to access the *External sensors* menu, active sensors will remain active when you exit the *External sensors* menu. When you exit data capture, however, all active external sensors will be automatically deactivated.

Status, Reading and Configuration

When capturing data, you can check the status of a sensor, manually take a reading from the sensor, or reconfigure the sensor using the methods described for testing the sensor interface in Chapter 5, *Configuring the Asset Surveyor Software*.

Activation and configuration of a laser rangefinder is also accessed via the **EXT** softkey.

Automatic Activation of the Laser Interface

If you have preconfigured the laser interface and have set the *Auto-connect* configuration field to Yes, then Asset Surveyor will automatically attempt to activate the laser interface when you start a data file.

If you have not preconfigured the laser interface to automatically connect (i.e. activate), then you can manually activate it via **EXT**.

Automatic Deactivation of the Laser Interface

If you press **EXT** to access the *External sensors* menu, an active laser interface will remain active when you exit the *External sensors* menu. When you exit data capture, however, the laser interface will be automatically deactivated.

Status, Reading and Configuration

When capturing data, you can check the status of the laser, take a reading from the laser, or reconfigure the laser interface using the methods described for testing the laser interface in Chapter 5, *Configuring the Asset Surveyor Software*.

Recording Laser Offsets

When the laser rangefinder interface is activated inside data capture, data received from the rangefinder can be logged to the current data file as an offset for the current feature.

If you activate a laser rangefinder within data capture and then take a laser reading, Asset Surveyor will respond in one of three ways:

- If you are capturing a point feature, Asset Surveyor will display the message 'Offset received' on the GPS status line. The offset for the current feature will be updated accordingly. This can be viewed or edited by pressing the **OFFSET** softkey.
- If you are capturing a line or area feature, Asset Surveyor will display the following warning message:

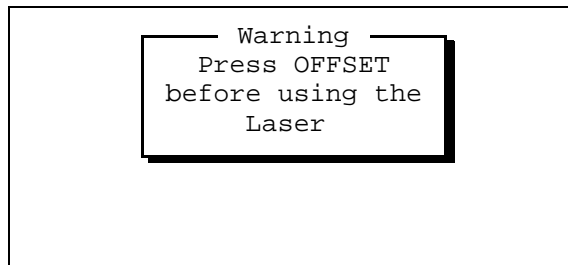

You must press **OFFSET** to pop up the offset entry form before recording an offset for a line or area feature with the laser rangefinder. You must then manually specify the direction of the offset (to the left or right of your direction of travel) and press **OK** to save the offset.

- If you are not currently capturing a feature at all, Asset Surveyor will display the following warning message:

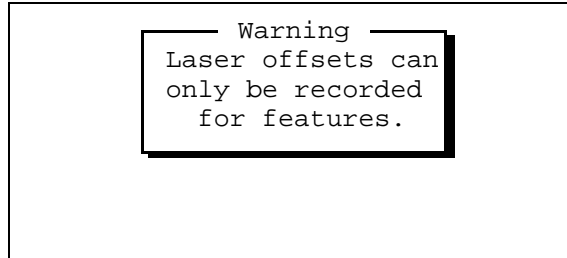

You can record as many offsets as you like for a feature, but only the last offset you record will actually be stored by Asset Surveyor. A feature only has *one* associated offset.



Tip – If you are recording a line feature using an offset (to travel along parallel to the line) and you reach a point where you are forced to use a different offset (e.g. you can no longer travel the same distance from the line feature), you should segment the line feature (using **SEG**) and then enter a new offset for the second segment of the line.

Main Menu/ Data Capture/ Exiting

When you have finished capturing features to a data file, you can exit data capture by pressing **Esc** on the *Start feature* menu. When you do, Asset Surveyor asks you to confirm your intentions:

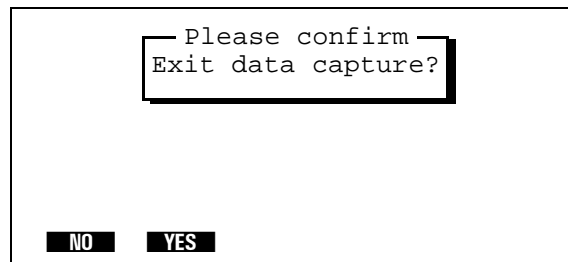

Main Menu/ Navigation

You can use the Asset Surveyor software together with a Trimble GPS receiver to determine and record your current position. You can also use Asset Surveyor and a GPS receiver to navigate to a position of interest. This can be a position which you have keyed in from a map, a waypoint which has been loaded into the TDC2 from Pathfinder Office, or the position of a feature in an Asset Surveyor data file.

Navigation is traditionally associated with ensuring that an aircraft or ship follows a prescribed course when traveling from A to B, but you can also use navigation to re-visit features which have been previously surveyed, and to identify a specific feature which may require maintenance.

As with other Trimble products, Asset Surveyor maintains a list of waypoints: positions which you can name for future reference and for navigating to or from.

Even if you are not wishing to navigate to a particular point, you can use Asset Surveyor's navigation screens to view your current speed and heading.



Note – Navigation using GPS is effective only within the limits of real-time GPS accuracy. With RTCM real-time differential corrections, you can navigate to an accuracy of 1–10 m (depending on your GPS receiver, GPS conditions, the frequency at which RTCM corrections are received, etc.). Without any form of real-time differential corrections, you are at the mercy of Selective Availability (SA), which means that you can only navigate to an accuracy of 15 to 100 m or more. Autonomous navigation (without real-time corrections) can still be useful to get you to the right suburb, or the right end of a long street, but it may be less useful for locating a specific feature, especially if similar features are near to each other.

The NAV1, NAV2 and NAV3 Forms

The Asset Surveyor software provides three navigation forms, called **NAV1**, **NAV2** and **NAV3**. Whenever you enter Asset Surveyor's navigation system, by selecting the *Navigation* entry in either the *Main menu* or the *GPS operations* menu, Asset Surveyor will display whichever of the three navigation forms you were last using. When you first use Asset Surveyor to navigate, the default form is **NAV1**.

The three navigation forms differ only in their first two fields. The heading of each form shows the start and end waypoints, both of which are optional. The three navigation forms are:

NAV1:

Dist to go:				
Brng to go:				?
Heading:			102°T	
Time:		?	24km/h	
Change course:				?
NAV1	NAV2	NAV3	START	END

NAV2:

Go:		North	2478m	
Go:		East	1276m	
Heading:			34°T	
Time:	00h47m		4km/h	
Change course:			5°→	
NAV1	NAV2	NAV3	START	END

NAV3 :

Dist to go:		2492m
X-track go:		←3m
Heading:		36°T
Time:	01h14m	2km/h
Change course:		←2°
NAV1 NAV2 NAV3 START END		

You can use the **NAV1**, **NAV2** and **NAV3** softkeys to switch between the three navigation forms.

The **NAV1** and **NAV2** navigation forms are generally used as two alternative methods of navigating to an end waypoint; the optional start waypoint is not used by these two forms. The **NAV1** form is best when you are navigating with a compass across open countryside; the **NAV2** form is best when you are navigating in a built-up area and your movement is restricted to rectangular city blocks. The **NAV3** navigation form shows cross-track error and enables you to travel along the shortest path between two waypoints without the need for a compass.

The fields of the three navigation forms are as follows:

- *Dist to go.* The distance remaining between the current GPS position and the end waypoint. This is the shortest great-circle distance to the end waypoint, computed on your local datum. If the end waypoint has not been selected this first field will be null.



Note – The great-circle distance is the shortest distance between two points on the surface of a sphere. It does not precisely match the approximations used for compass navigations, but the differences for distance computed less than 500 km are negligible.

- *Brng to go.* The bearing (angle) which you should follow in order to take the shortest path between the current GPS position and the end waypoint. The bearing will be displayed with a trailing 'T' if it is relative to true north or an 'M' if it is relative to magnetic north. If the end waypoint has not been selected this field will be null.
- *Heading.* Your current direction of travel. This is the angle between the last two GPS positions computed, and is therefore likely to be most accurate if you are receiving RTCM differential corrections or if you are traveling fast enough to nullify the effects of SA. This field is also shown with a trailing 'T' or 'M', which indicates that the heading is relative to either true or magnetic north. The heading will be displayed whether or not you have chosen any waypoints.
- *Time to go and Velocity.* The field labeled *Time* shows both the expected time to reach the target waypoint (if any) and the current velocity across the ground. The time to go field takes your current heading into account and will show a larger value if you are not heading directly toward the target waypoint. The velocity is three-dimensional, taking into account change in altitude as well as horizontal velocity. The current velocity will be displayed whether or not you have chosen any waypoints.
- *Change course.* The modification to your current course which will bring you back onto the shortest path to the end waypoint. The ← and → arrows indicate whether you should veer to the left or to the right, while the numeric value indicates the magnitude by which your course should vary. As with the heading field, this value is susceptible to the effects of SA, and will be most useful if you are receiving RTCM differential corrections or are traveling at a reasonable speed.

- *Go North/South, Go West/East.* The first two fields of the **NAV2** form indicate the distance from the current GPS position to the end waypoint as two Cartesian distances, with directions as indicated. If the end waypoint has not been selected this field will be null.
- *X-track go.* The direction and distance to the shortest line between the start and end waypoints. The direction (left or right) is indicated by ← or → arrows; the numeric value indicates the distance you should travel in that direction to get back on line. Unless both start and end waypoints have been selected, this field will be null.



Tip – You can change any of the above units or the style of display in the *Units and display* configuration form.

When GPS position information is temporarily unavailable (e.g. due to one or more satellites being obscured, or due to a high PDOP), Asset Surveyor will still display the most recent navigation information, but will flash the following message on the title of the navigation form:

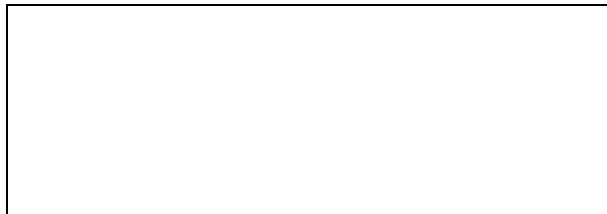

Main Menu/ Navigation/ Waypoints

For a detailed description of how to create and manage waypoints in Asset Surveyor, refer to page 7-54 of this chapter. This section describes how to select waypoints for navigation purposes.

Selecting Waypoints

When navigating, you can select the start waypoint by pressing **START** and the end waypoint by pressing **END**.

When you press either **START** or **END**, Asset Surveyor pops up the menu of current waypoints, which includes (at the end of the menu) the null waypoint (designated by the currently configured null string: '?', by default).

You can select a waypoint from this menu or you can 'clear' the start or end waypoint by selecting the null waypoint.

When you first use Asset Surveyor to navigate, the start and end waypoints will be null. Once you have selected **START** and/or **END** waypoints, these remain the selected waypoints for subsequent navigation sessions, until you change them.

Navigating to a Waypoint from your Current Position

If you have neither start nor end waypoints selected (i.e. both are the null waypoint), the title of each navigation form will be:

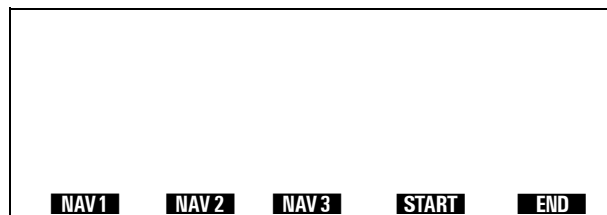

If you wish to navigate to a specific waypoint from wherever you happen to be at the time, press **END** and select that waypoint from the menu. The title of the navigation form will change to:

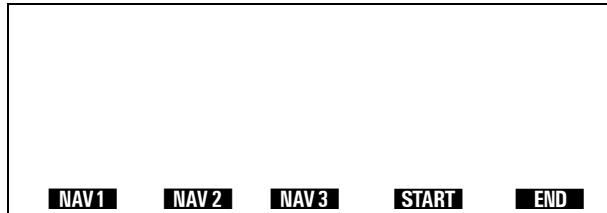

where the end waypoint's name is shown. Navigation using an end waypoint only is usually carried out using either the **NAV 1** or **NAV 2** navigation forms.

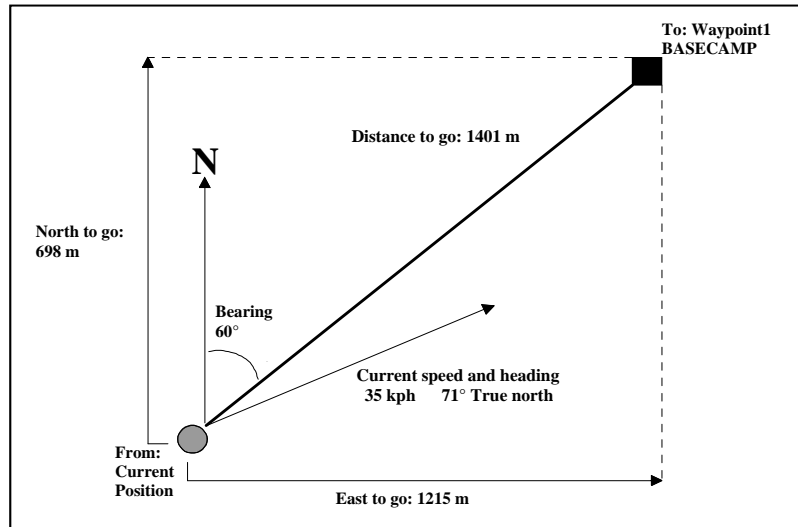
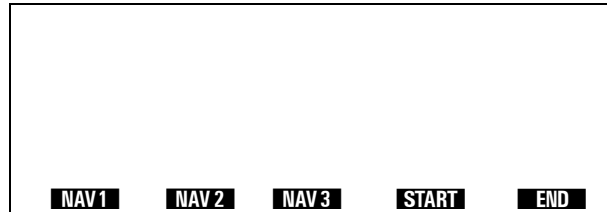

Figure 7-1 Navigation from your Current Position

Navigating from Waypoint to Waypoint

If you wish to navigate from a specific waypoint to another specific waypoint, select start and end waypoints from the menu (using **START** and **END**). The title of the navigation form will change to:



where both the start and end waypoints' names are shown. Navigation from waypoint to waypoint lets you take advantage of the **NAV 3** form's cross-track error indicator.

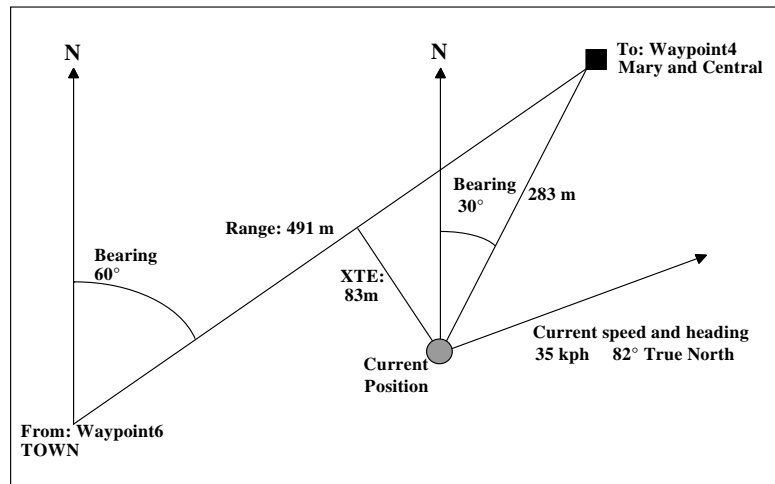
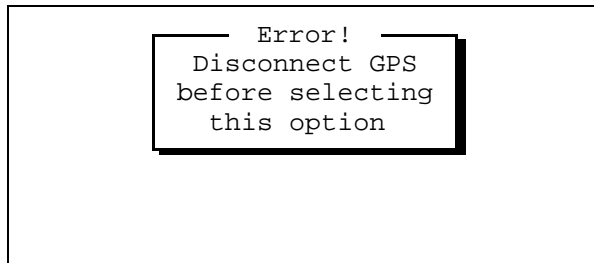

Figure 7-2 Navigation from Waypoint to Waypoint

Main Menu/ File Transfer

If you select the *File transfer* entry from Asset Surveyor's *Main menu*, Asset Surveyor will enter file transfer mode. You can use this mode to transfer data files, data dictionaries, language files, waypoints, almanacs and coordinate system files between the Asset Surveyor software and Pathfinder Office.

File transfer mode uses the same serial port as the GPS interface, so you must disconnect GPS before selecting *File transfer*. If you do not, Asset Surveyor pops up the message:



Once GPS is disconnected, ensure your TDC2 is connected to your PC, and select *File transfer* again. Asset Surveyor then displays the file transfer status form:

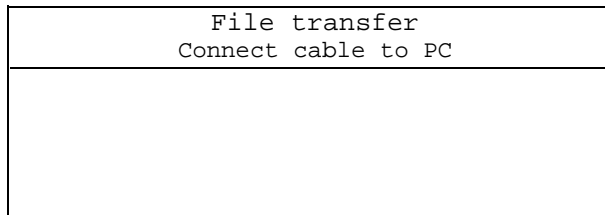

Throughout the file transfer session, Asset Surveyor will display status information on the second line of this form, indicating whether or not the file transfer operations are proceeding correctly.

All file transfer operations are controlled from the Pathfinder Office, Data Transfer Utility. You can exit file transfer mode at any time by pressing (Esc) on the TDC2. If a transfer operation was in progress at the time, this will be aborted.

Transferring Data Files to and from the PC

Refer to the Pathfinder Office documentation for details of how to transfer files to and from the Asset Surveyor.

Table 7-1 shows the data types that are available for transfer between your office computer and an Asset Surveyor datalogger.

Table 7-1 Data Types

Data Type	Receive	Send
Almanac	No	Yes
Data	No	Yes
Data Dictionary	Yes	No
Other	Yes	No
Waypoint	Yes	Yes

Types of other files

- *ASCOORD.DAT*. A file containing coordinate system definitions. This can be edited on your PC using the supplied ASSETED.EXE program, and then loaded onto a fleet of TDC2's to ensure that they all have the same coordinate systems (and only those coordinate systems which are required for your application).

- *.LNG. A number of specific Asset Surveyor language files (see Table 7-2). You can load the language(s) you require onto your TDC2, and then change the language used by the Asset Surveyor software via the *Language* menu in the *Units and display* configuration form.

Table 7-2 Languages

Language File	Language
DEUTSCH.LNG	German
ENGLISH.LNG	English (default language)
ESPANOL.LNG	Spanish
FRANCAIS.LNG	French
PORTUGAL.LNG	Portuguese
RUSSIAN.LNG	Russian

Main Menu/ Utilities Menu

The *Utilities* menu, which is accessed from the Asset Surveyor software's *Main menu*, provides a number of miscellaneous operations:

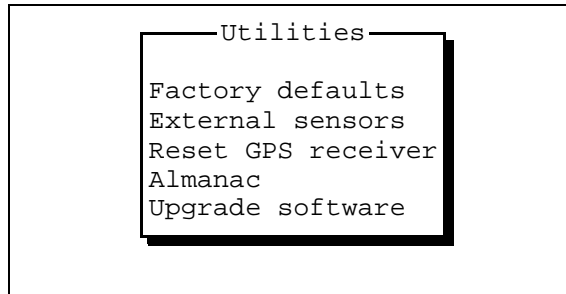

The following sections describe the entries in the *Utilities* menu.

Main Menu/ Utilities/ Waypoints

An Asset Surveyor waypoint is a named three-dimensional position. A waypoint can be used to record a geographic point of interest such as a survey mark, an excavation site, or a previously-surveyed feature.

Waypoints can be specified in local coordinates (i.e. as north, east and altitude in a local coordinate system), but Asset Surveyor stores all waypoints as latitudes, longitudes and altitudes on the WGS-84 datum. This enables you to export and use waypoints in other coordinate systems.

The Asset Surveyor software maintains a single waypoint file, which contains a list of waypoints. There is no fixed limit to the number of waypoints you can record in Asset Surveyor, apart from the limit of available data storage space on the TDC2.

You can view the menu of waypoints and perform waypoint management operations in a number of ways:

- By selecting the *Waypoints* entry from the *Utilities* menu.
- By selecting the *Waypoints* entry from the *GPS operations* menu.
- Whenever you are selecting a start or end waypoint for navigation.
- Whenever you are selecting a waypoint as a reference position for a GPS base station.
- Whenever you are selecting a waypoint as a reference position for *Over and Up* mode.

The menu of waypoints looks as follows:

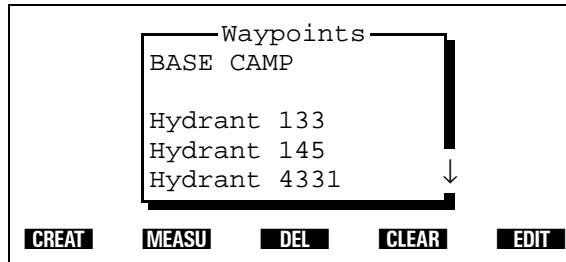

You can select a waypoint by using the normal menu selection methods described on page 4-8. You can perform various waypoint management operations using the softkeys. These operations are described in the following sections.

Main Menu/ Utilities/Waypoints/ Creating

You can create a waypoint and add it to the *Waypoints* in a number of ways:

- By pressing **CREATE** on the *Waypoints* menu.
- By pressing **WAYPT** on the GPS *Position* form. This creates a waypoint using the current GPS position and lets you name the waypoint and possibly edit the position before saving it to the waypoints file and adding it to the *Waypoints* menu.
- By pressing **WAYPT** on one of the position forms when reviewing data (see page 8-11). This creates a waypoint using a particular feature's position and lets you name the waypoint and possibly edit the position before saving it to the waypoints file and adding it to the *Waypoints* menu.

The waypoint creation form is as follows:

Create waypoint 23	
Name:	
North:	?
East:	?
Alt (MSL):	?
Datum:	NZGD 1949
Zone:	UTM Zone 59
HERE	

The title of the form indicates the number of this new waypoint. As waypoints are created, they are added to the end of the *Waypoints* menu, so this number informs you how many waypoints are currently in the menu. However, the waypoint numbers will vary as waypoints are deleted, so you cannot rely on a particular waypoint retaining the same number.

You can enter the waypoint's name and location into the remaining fields on this form. You must supply non-null values for all fields before pressing to save the waypoint and add it to the *Waypoints* menu.



Note – When entering waypoints from a map, you may have to estimate the waypoint's altitude, using the map's contours, or using your knowledge of the area; you cannot leave the altitude field empty.



Tip – If you normally use one coordinate system and wish to enter waypoints from a map which uses a different coordinate system, switch to the map's coordinate system (using the *Coordinate system* entry of the *Configuration* menu), enter the waypoints, then switch back to your normal coordinate system. Because Asset Surveyor projects all waypoints back to the WGS-84 datum, the positions can be used in any coordinate system defined for that area; although the actual coordinates of a waypoint will change when the coordinate system is changed, the physical position of the waypoint on the earth's surface will be preserved.

The *Create waypoint* form supplies a **HERE** softkey which, when GPS is active, can be pressed to fill in the waypoint's location with your current GPS position.



Note – Unless you are receiving RTCM differential corrections or are using a P(Y)-code receiver, the accuracy of the current GPS position will be subject to Selective Availability (SA).

Main Menu/ Utilities/Waypoints/ Editing

You can view the details of a particular waypoint, and optionally edit them, by highlighting that waypoint in the *Waypoints* menu and pressing **EDIT**. The *Edit waypoint* form is very similar to that for creating new waypoints, but is filled in with details of the selected waypoint:

Edit waypoint 3	
Name:	
North:	5742765.70m
East:	2479077.53m
Alt (MSL):	41.32m
Datum:	NZGD 1949
Zone:	UTM Zone 59
HERE	

When you have finished viewing or editing the waypoint, press **OK** to save it and return to the *Waypoints* menu, or press **Esc** to return to the menu without saving any changes.



Tip – Selecting a waypoint from the menu is equivalent to pressing **EDIT**, if you have accessed the *Waypoints* menu from the *Utilities* or *GPS operations* menu.

The *Edit waypoint* form supplies a **HERE** softkey which, when GPS is active, can be pressed to fill in the waypoint's location with your current GPS position.



Note – Unless you are receiving RTCM differential corrections or using a P(Y)-code receiver, the accuracy of the current GPS position will be subject to Selective Availability (SA).

The *Datum* and *Zone* fields are displayed to remind you of the currently configured coordinate system; they are not edible in the *Edit waypoint* form.

Main Menu/ Utilities/Waypoints/ Deleting

Deleting Single Waypoints

You can delete a particular waypoint from the *Waypoints* menu (and the waypoints file) by highlighting that waypoint and pressing **DEL**. Asset Surveyor asks you to confirm your intention:

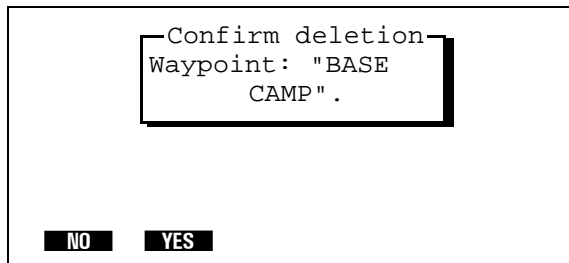

Press **YES** to delete the waypoint, or **NO** to retain it.

Deleting All Waypoints

You can delete all waypoints from the *Waypoints* menu (and the waypoints file) by pressing the **CLEAR** softkey. Asset Surveyor asks you to confirm your intention:

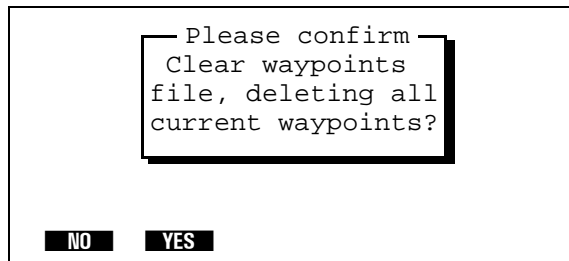

Main Menu/ Utilities/Waypoints/ Measuring Between

Asset Surveyor provides a facility for measuring the distance and bearing between selected waypoints. Press **MEASURE** to pop up the *Measure* form:

Measure	
Start waypt:	
End waypt:	Fuel dump
Distance:	2500.51m
Bearing:	146°43'18" T
PREV NEXT STEP	

When you select a waypoint for either the *Start waypt* or *End waypt* field, Asset Surveyor computes and displays the distance and bearing from *Start waypt* to *End waypt*.

You can change the value of the *Start waypt* or *End waypt* menu fields in the usual way, or by making use of the three softkeys provided by this form:

- You can press **PREV** to select the previous waypoint in the waypoint menu.
- You can press **NEXT** to select the next waypoint in the waypoint menu.



Note – If you press **PREV** or **NEXT** when the *Start waypt* field is highlighted, it is this waypoint which will be changed. If you press **PREV** or **NEXT** when any other field of the *Measure* form is highlighted, it is the *End waypt* which will be changed.

- You can press **STEP** to put the *End waypt* value into the *Start waypt*, and the next waypoint in the waypoint menu into the *End waypt* field.



Tip – You can use **STEP** to step through a route (a sequence of waypoints recorded in the order that you wish to visit them) and see the distance and bearing for each leg of the route.



Tip – You can change the units in which the *Distance* field is displayed by changing the value of the *Distance* units in the *Units and display* configuration form (see page 5-75). In that same configuration form, you can also change the north reference from True to Magnetic, or vice versa, by changing the value of the *North ref* field (see page 5-81).

Main Menu/ Utilities/ Factory Defaults

You can reset all of the Asset Surveyor software's configurable aspects to the Trimble factory defaults by selecting the *Factory defaults* entry from the *Utilities* menu. If you select *Factory defaults*, Asset Surveyor will ask you to confirm that this is your intention:

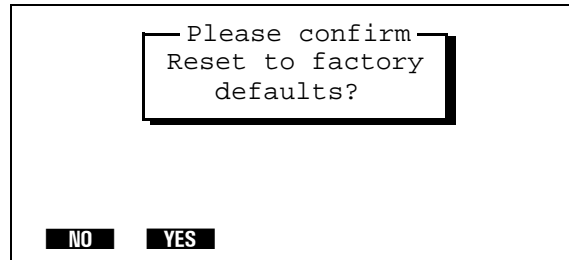

If you press **NO**, you will be returned to the *Utilities* menu and the system configuration will remain as it is.

If you press **YES**, Asset Surveyor will delete its configuration files and rebuild them with factory default values, then it will reboot the TDC2 to ensure that the factory default settings take effect. If Asset Surveyor has previously recorded an almanac from a Pathfinder GPS receiver, this will also be deleted.



Note – Resetting to factory defaults will **not** delete data dictionaries, data files, languages, coordinate systems, barcode wand drivers or waypoints. However it **will** reset Asset Surveyor to the default language (English), the default coordinate system (latitude/longitude on the WGS-84 datum) and the default data dictionary (Generic).

Main Menu/ Utilities/ External Sensors

Testing an External Sensor

Asset Surveyor lets you pre-configure and pre-test an external sensor interface via the *External sensors* entry in the *Utilities* menu.



Tip – You should always test an external sensor interface before attempting to use the sensor for data capture. Configuration of a sensor interface is relatively complicated, and there are usually a number of ways in which the interface can be configured for a particular sensor. Only by testing the interface can you be sure that the sensor and Asset Surveyor will communicate correctly, and that the interaction is workable under field conditions.

Configuration of an external sensor interface was described in Chapter 5, Configuring the Asset Surveyor Software. The examples in the following sections presume that you have already configured two external sensors as follows:

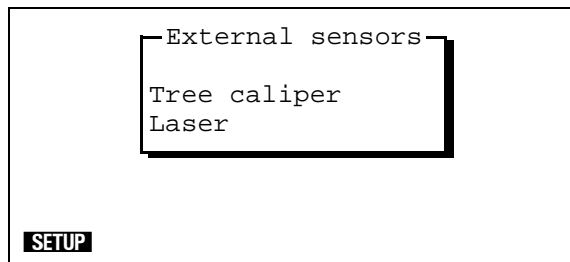

The *Geiger counter* is a sensor which records radiation levels. It outputs a reading to its RS232 port if requested by Asset Surveyor. The *Tree caliper* is a sensor which is used to measure the diameter of tree trunks. It emits a reading to its RS232 port whenever you press the *Measure* button on the caliper itself.



Note – Although you can pre-configure two external sensors, you can only connect and use one of them if you wish to use a barcode wand for attribute entry.

Activating a Sensor Interface

You can manually activate an external sensor by selecting it from the *External sensors* menu (accessed either from the *Utilities* menu or via an **EXT** softkey when capturing data). To activate a sensor, highlight its entry in the menu and press . When a sensor is active, a check mark (✓) will appear to the left of its name in the *External sensors* menu. For example, if you wish to activate the *Tree caliper* sensor, highlight it and press . The *External sensors* menu will then look as follows:

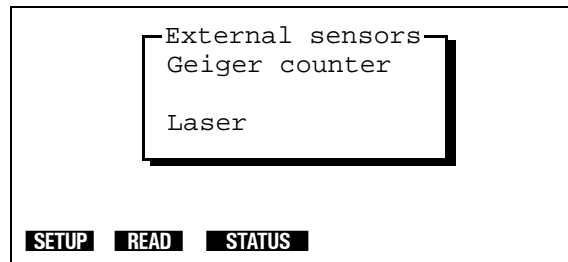

When a sensor is active (and highlighted), two further softkeys (**READ** and **STATUS**) appear.

When a sensor is activated, Asset Surveyor starts to communicate with it. If you have configured Asset Surveyor to display a status line or to emit an audible click whenever it logs data from the sensor, then you may begin to see or hear Asset Surveyor and the sensor communicating.

If you attempt to activate an external sensor on a serial port which is already in use by GPS, a barcode wand, the laser rangefinder interface or another sensor, Asset Surveyor displays the following message:

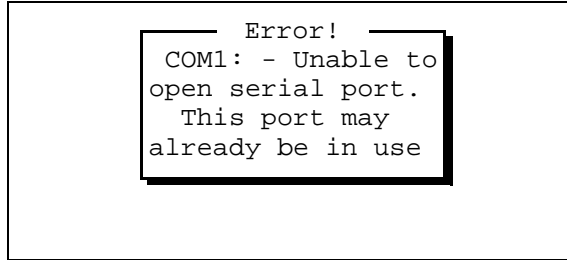
A screenshot of an error message box. The text inside the box is: "Error!
COM1: - Unable to
open serial port.
This port may
already be in use". The text is centered and appears to be in a monospaced font. The box has a thin black border.

```
      Error!  
  COM1: - Unable to  
  open serial port.  
  This port may  
  already be in use
```

and refuses to activate the new sensor.

Deactivating a Sensor Interface

You can manually deactivate an active external sensor by again highlighting and selecting it from the *External sensors* menu. When a sensor is deactivated, the check mark (✓) to the left of its name disappears, as do the **READ** and **STATUS** softkeys.

When you exit the *External sensors* menu and return to the *Utilities* menu, all active external sensors will be deactivated automatically.

Configuring a Sensor

The configuration of external sensors is described in detail in Chapter 5, Configuring the Asset Surveyor Software.

You can change the configuration of an external sensor while it is active by pressing **SETUP**. The only aspects of an external sensor which cannot be configured while it is active relate to the serial port it is using. Asset Surveyor will not provide a **COMMS** softkey on the sensor's configuration form while the sensor is active. If you wish to change the serial port or reconfigure the RS232 parameters for the sensor, you must deactivate it, configure it, and then re-activate it.

Reading from a Sensor

If an active sensor emits data unsolicited, you will be unable to manually request data from the sensor; Asset Surveyor will log data as it is received, using the configured logging *Intervals* for that sensor. As an example, most depth-sounders operate in this fashion, emitting one or more readings per second.

If an active sensor emits data only when a trigger or button is pressed on the sensor itself, you will also be unable to manually request data from the sensor using Asset Surveyor. A typical example of a triggered sensor is an electronic tree caliper.

If the sensor emits data only when requested via its RS232 line, Asset Surveyor can obtain data from the sensor by sending the configured *Data request* string. This is sent to the sensor in two circumstances:

- As determined by the configured *Interval* fields. (When you activate an external sensor from the *External sensors* entry in the *Utilities* menu, the *Not in feature* interval will be used.)
- When you press the **READ** softkey.



Tip – If the sensor is of the type where you wish to take only one (or very few) reading(s) per feature, and you need to be able to trigger the readings at precise moments, you should configure the sensor with intervals of None, and use the **READ** softkey to take readings when required.

Sensor Status

When an external sensor is active (and highlighted), you can press **STATUS** to pop up a status form for that sensor. For example:

Records:	Geiger counter	12
Display as:	512.34,332.13\0D\0A	

The first field of this form shows the number of data ‘records’ (or messages) which have been received from the sensor since it was activated, while the third field shows the content of the most recent record (using ‘\XX’ escape sequences to show any non-printable characters).

If the sensor to which you are connected emits purely binary data (i.e. no part of the data is ASCII text), you should change the value of the *Display as* field from ASCII to Binary. The third field of the form will then display every byte of data using a ‘\XX’ escape sequence.



Note – The Asset Surveyor software does not know when to expect data from an external sensor. It cannot, therefore, warn you when nothing is received from the sensor; its status form only shows you what *has* arrived from the sensor.

Main Menu/ Utilities/ External Sensors/ Laser

The Asset Surveyor software lets you activate and test a laser rangefinder via the *External sensors* entry in the *Utilities* menu. When you select *External sensors* from the *Utilities* menu, or press **EXT** Asset Surveyor pops up the menu of external sensors, containing the *Laser* entry:

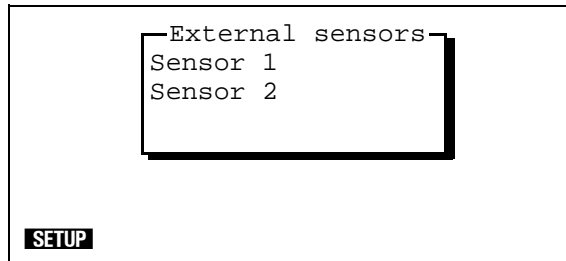

The **SETUP** softkey leads to the configuration form for the highlighted sensor.

Activating the Laser Interface

You can manually activate the laser rangefinder by selecting the *Laser* entry from the *External sensors* menu (i.e. highlight the *Laser* entry and press ) . When the rangefinder interface is active, a check mark (✓) will appear to the left of the *Laser* entry in the *External sensors* menu. For example:

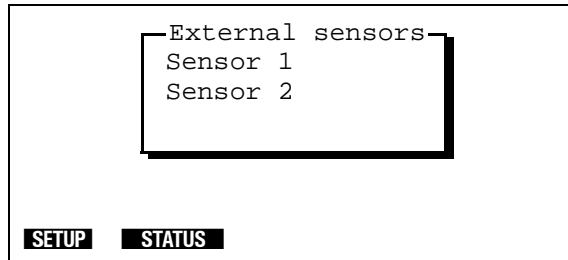

When the laser rangefinder interface is active (and highlighted), a **STATUS** softkey also appears. Once the laser rangefinder interface has been activated, Asset Surveyor will accept communications from the laser.

You can configure Asset Surveyor to automatically activate a laser rangefinder on entry to data capture, as described in Chapter 5, *Configuring the Asset Surveyor Software* for general details of how to connect a laser rangefinder to your TDC2. See also the section covering your particular laser rangefinder for cabling and connector diagrams.

Deactivating the Laser Interface

You can manually deactivate an active laser interface by again highlighting and selecting the *Laser* entry from the *External sensors* menu. When the laser interface is deactivated, the check mark (✓) to the left of the *Laser* menu entry disappears, as does the **STATUS** softkey.

When you exit the *External sensors* menu and return to the *Utilities* menu, Asset Surveyor will automatically deactivate the laser interface.

Reading Laser Offsets

You take a reading from a laser rangefinder by aiming at a target point and pressing the trigger on the rangefinder. You may also need to press a button on the rangefinder to send the measurement to the datalogger. Consult the section in Appendix G of the *TDC2 Asset Surveyor Operation Manual* that covers your particular rangefinder for further details.

Laser Status

When the laser rangefinder interface is active (and the *Laser* entry is highlighted in the list of external sensors), you can press **STATUS** to pop up a status form for the rangefinder:

Criterion 300	
Bearing:	
Slope dist:	6.230m
Inclination:	0.0°

This form shows the most recent offset received from the laser rangefinder. If you take further readings using the rangefinder, these will appear on the status form, replacing the previous reading. You cannot edit the fields in the laser rangefinder's status form.



Note – If you take a laser measurement in the laser status form when a data file is open, this offset will be recorded to the data file if a point feature is currently open.

Main Menu/ Utilities/ Reset GPS Receiver

You can reset the memory of a Pathfinder GPS receiver using the *Reset GPS receiver* entry in the Asset Surveyor software's *Utilities* menu.

It will normally be quite unnecessary to reset the GPS receiver's memory, but if for some reason the receiver firmware malfunctions, resetting its memory can often fix the problem.



Caution – Resetting the GPS receiver's memory will force the receiver to perform a cold restart. The receiver may take up to 15 minutes to reacquire signals from the GPS satellites.

When you select *Reset GPS receiver*, Asset Surveyor will check the currently connected GPS receiver. Asset Surveyor will beep and return to the *Utilities* menu if there is none, or if the connected GPS receiver is one of the following:

- a Series 4000 receiver,
- a Centurion or Trimpack III.

If the currently connected GPS receiver does not appear in the list above, Asset Surveyor will ask you to confirm that you wish to reset its battery-backed memory:

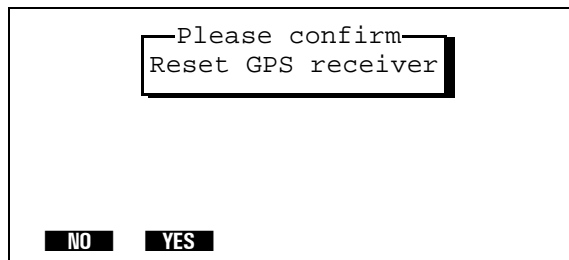

If you press **YES**, the receiver's memory will be reset. After answering this question, you will be returned to the *Utilities* menu.

If, after resetting your GPS receiver's memory, the receiver still fails to acquire GPS satellite signals within 15 minutes, you should contact your nearest Trimble Assistance Center for advice.



Note – If your GPS receiver is one of those listed above, consult the receiver's Operation Guide for instructions on how to manually reset the receiver's battery-backed memory.

Main Menu/ Utilities/ Almanac

You can check the date on which Asset Surveyor last recorded an almanac from a Pathfinder GPS receiver by selecting the *Almanac* entry in the *Utilities* menu. Asset Surveyor will display the following information form:

	Almanac
Date:	03/13/1995 Mon

If Asset Surveyor has never recorded an almanac (since the software was installed, or since you last reset it to *Factory defaults*), it will display ‘?’ instead of the almanac date.



Note – Asset Surveyor will not record an almanac from a Series 4000 GPS receiver.

**Main Menu/
Utilities/
Upgrading the Asset
Surveyor Software**

The *Upgrade software* entry in the Asset Surveyor software's *Utilities* menu lets you upgrade to a new version of the Asset Surveyor software, or to another Trimble TDC2 software product.

Chapter 3, Installing the Asset Surveyor Software, describes the equipment required to upgrade the TDC2 and provides complete instructions for the upgrading procedure.

Main Menu/ Base Station

If you select the *Base station* entry from Asset Surveyor's *Main menu*, Asset Surveyor will act as a GPS base station in conjunction with a Pathfinder GPS receiver.



Note – The Asset Surveyor software cannot act as a base station with a Series 4000 GPS receiver. If you wish to use a Series 4000 receiver as a base station, you should contact Trimble and request information on the 'Universal Reference Station' PC software.

When you select the *Base station* entry from the *Main menu*, Asset Surveyor first checks that it is connected to and able to communicate with a Pathfinder GPS receiver. If it is connected to a Series 4000 GPS receiver, or is not connected to a GPS receiver at all, it will not continue with the Base Station session.

Configuring Base Station Options

The first step in setting up a GPS base station is to configure the GPS *Base stn options*, as described on page 5-51.

You can re-configure the base station options once the base station has started operating, but it is good practice to configure Asset Surveyor first, so that when a base station is started it can immediately log the data you require.

Main Menu/ Base Station/ Creating a File

After you have selected *Base station* from the *Main menu*, and Asset Surveyor has confirmed that you have a Pathfinder GPS receiver connected, the *Create file* form appears:

```
                Create file
File:                               B5010613
Free space:                           490kB

[TIME]
```

Asset Surveyor suggests a default file name, as described in the File Naming Conventions section of Chapter 4. The default name appears in the *File* field. You can accept this default name, edit it, or type in a new name altogether. File names can be at most eight characters long, and can be composed of letters and digits only (that is, no spaces or punctuation characters).

The other field of the form, *Free space*, reminds you how much data file storage space remains on your TDC2. You cannot edit this field.

Press when you have entered a different file name, or to accept the default name. Asset Surveyor checks that the name of the new file is unique. If it is not, Asset Surveyor warns you:

```
      Please confirm
      A file with this
      name exists. Do
      you want to append
      to it?

[NO] [YES]
```

If you press **YES**, Asset Surveyor will re-open the existing file and log base station information to it. If you press **NO**, you will be returned to the *Create file* form where you can enter a new file name.



Note – When operated as a base station, Asset Surveyor always opens a data file to which it can log GPS measurement data for subsequent postprocessing. If you wish to operate an exclusively real time base station, and do not wish to log data to the TDC2, you should configure the *Position and Measurement* logging intervals for the base station to None.

Main Menu/ Base Station/ Antenna Options

After creating or selecting a base station file, Asset Surveyor will pop up the *Antenna options* form:

Antenna	
Height:	
Measure:	Vertical
Type:	EC

You should verify that the configured antenna height and type are correct before pressing to proceed. See Table 5-1, page 5-41 for a list of antenna types.

Main Menu/ Base Station/ Reference Position

Once you have accepted a file name, Asset Surveyor lets you enter a *Reference position* for the base station. This is the known position at which the base station is situated. The default given is the value which was last specified as a reference position:

Reference position		
North:		
East:	?	
Alt (MSL):	?	
Datum:	NAD-83	
Zone:	California-6	
WAYPT	UNKNOWN	HERE

You can enter the reference position from a map, or from the results of a previously-conducted control survey. If you provide a reference position for the base station, you must enter values into all three fields in the *Reference position* form. If you do not know the location of your base station, you can press  or **UNKNOWN** to proceed.



Note – You do not have to enter a reference position for a base file in the field, unless you are operating a real time base station. You will have to specify a reference position (using Pathfinder Office) before using a base file to differentially correct rover files. You can also use Pathfinder Office to change a base file's reference position.



Note – The reference position you enter will typically be the position of some reference mark on the ground. Asset Surveyor combines this with the Antenna height which you previously specified to calculate the position of the GPS antenna's phase center (APC). This is the position which will be logged in the base station file.

If you have previously recorded the location of the base station as a waypoint, you can press **WAYPT** to pop up the menu of waypoints. Selecting a waypoint from this menu automatically fills in the *Reference position* fields with the location of that waypoint.



Tip – If you regularly operate a base station on more than one location, you can set up waypoints for each base location. This makes selection of the reference position very easy. You can also use Asset Surveyor’s navigation abilities to assure yourself that you are specifying the correct waypoint as the reference position for a base station.

You can press **HERE** to fill in the reference position with the current GPS position (if any).



Note – Unless you are receiving RTCM differential corrections, the accuracy of the current GPS position will be subject to Selective Availability (SA).



Note – If you choose to append to an existing data file, Asset Surveyor will not permit you to specify a new reference position. If you have moved to a different location, you *must* create a new base file.

Main Menu/ Base Station/ Status Form

Once you have created a base station file and (optionally) entered a reference position for the base station, Asset Surveyor will start logging base station information. When operating as a base station, Asset Surveyor displays the *Base station* status form:

Base station	
	481kB
Start	
Time:	02:14:01 pm
Date:	10/06/1993 Wed
Logging for:	1h26m
SETUP	

The fields on the *Base station* status form are as follows:

- *Free space.* The amount of available data storage space remaining on the TDC2.
- *Start.* The time and date that the base station started logging to this data file.
- *Logging for.* The time, in hours and minutes, for which Asset Surveyor has been logging base station data to this data file (in the current session).



Note – The title of this form will be *RTCM base station* if RTCM output has been enabled.

This form simply displays the status of the base station; none of these fields are editable.

You can press **SETUP** to reconfigure GPS *Base stn options*.



Note – You cannot turn RTCM output on **after** starting a base station. If you wish to turn RTCM output on, you must exit base station mode, enable RTCM output and then re-start your base station.

You can press **[GPS]** to pop up the *GPS operations* menu. The only entry missing from this menu when in base station mode is the *Navigation* entry, which is unnecessary given that a base station must be stationary.

If you want to operate the Pro XR or Pro XRS receiver as an Unattended Real-Time Base Station, remove the datalogger at this stage and attach the battery to the Unattended Real-Time Base Station power cable (P/N 32247). The receiver will re-power on and begin transmitting the RTCM corrections soon after.



Note – When the Pro XR or Pro XRS receiver is operated as an Unattended Real-Time Base Station, there is no base data stored on the receiver. If you wish to be able to differentially correct your rover data, you must leave a TDC2 connected to the receiver.

When you have finished operating the Asset Surveyor software as a GPS base station, you can exit base station mode by pressing **[OK]** or **[Esc]**.

Main Menu/ Information for New Users

The *Info for new users* menu entry, and the **INFO** softkey on the *Main menu*, provide access to a number of pages of information for new users of the Asset Surveyor software.

Func then GPS key	=	Configuration
Func Y	=	Review file
Func X	=	Enter note
Func A	=	Contrast <
Func B	=	Contrast >

Func E	=	Backlight
Func C	=	Home
Func D	=	End
Func K	=	Page up
Func Q	=	Page down

8 Other Operations

The following sections describe additional Asset Surveyor features which are *not* accessed using the *Main menu*.

Entering a Note

Whenever you are capturing data to a file, you can press **Note** to enter a note. Asset Surveyor lets you type any characters at all into a note, which can be up to 80 characters long.

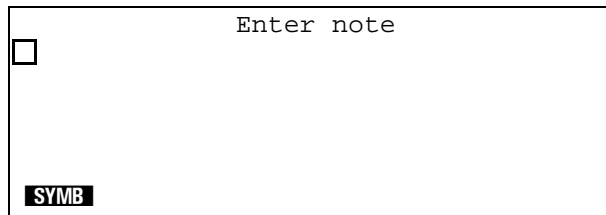

You can make use of **SYMB** to enter any special characters. Pressing **Enter** or **↓** moves the cursor to the next line of the note; pressing **↑** moves the cursor to the previous line of the note. Pressing **Home** moves the cursor to the start of the current line, and **End** moves the cursor to the end of the current line.

When you have finished entering the note, press **OK** and Asset Surveyor will store the note at the end of the current data file. If you decide that you no longer wish to save the note, press **Esc**.

Notes can be reviewed and edited as described in the following section. When the data file is output to Pathfinder Office, the resulting SSF file will contain any notes which you entered, as well as some which Asset Surveyor writes to the data file itself (e.g. 'Logging started' and 'Logging stopped').

Other Operations/ Reviewing and Editing Data

Unless you are already reviewing a data file, you can press **View** to review (and optionally edit) an existing data file.

If you press **View** outside of data capture, Asset Surveyor pops up a menu of data files:

```

Review file
R100418a
R100509a
R100613a
B3100615
  
```

Select a file to review from this menu. The file in this menu which is highlighted initially is the file which was most recently reviewed or used for capturing data.

If you press **View** while capturing data to a file, or select a specific file to review from the *Review file* menu, Asset Surveyor scans the file for features and notes and then displays the following form:

```

Review <<R100509a>>
1:          Logging started ...
2:                               Town
3:                               Gas station
4:                               Bank
5:                               Highway
6:
SEARCH  POS  DEL  UNDEL
  
```



Tip – It may take Asset Surveyor some time to scan a large data file. If you intend to review and edit data files frequently, you should consider creating and maintaining smaller data files (perhaps starting a new one every few hours) in order to minimize the amount of time you must wait before reviewing your data.

Asset Surveyor will highlight the last feature or note which was recorded to the data file being reviewed. You can move the highlight up and down the list of features and notes.

You can view the attributes of a particular feature or the contents of a particular note by positioning the highlight on that feature or note and pressing **Enter**. The forms for reviewing attributes and notes are very similar to the forms for originally entering attributes and notes, e.g.

Review<<Town>>	
Name:	
Population:	1035
Gas stations:	2
Any open 24 Hrs?:	No
Banks:	0

and

Review note
09:16:20 am
09/30/1993 Thu
(Local time)

You can edit any attributes of a reviewed feature, or the contents of a note, then press **OK** to save the feature or note. If you are just viewing the feature or note, press **Esc** to return to the list of features and notes for the data file which is under review.

You can view the position(s) of a feature by pressing **POS**, and you can also view and/or edit a feature's offset by pressing **OFFSET** in the position review form.



Note – If you review a file while you are capturing data to it, Asset Surveyor may continue to log GPS positions and/or ESP data to that file during the review session. This data will be associated with whichever feature was being captured at the time you pressed **View**.
You cannot update the GPS position or ESP data associated with a previously-recorded feature.



Tip – If you have entered a feature's attributes correctly but have recorded the wrong position, you can review that feature, then return to the list of features in data capture and press **REPEAT**. The attribute values of the incorrect feature will become the default values for the new feature, and you can then correctly record the feature's GPS position. The original feature should then be deleted.

You can press **Esc** to exit data review, or you can press a softkey to perform another operation. When you press **Esc**, Asset Surveyor asks you to confirm your intention.

```

  Please confirm
  Exit review?
  NO      YES

```

The four softkeys on the list of features and notes are described in the following sections.

Other Operations/ Review/ Searching

The **SEARCH** softkey initiates a search through the current data file. Asset Surveyor asks you to specify a pattern to search for, and a direction:

	Search	
Pattern:		
Direction:		Backwards

The fields on this form are as follows:

- *Pattern.* A character string for which Asset Surveyor should search. This can contain any characters; a **SYMB** softkey is made available to assist with the specification of characters which are difficult to type on the TDC2's keyboard. You must specify a non-null pattern before Asset Surveyor will attempt a search.
- *Direction.* Because Asset Surveyor initially positions the highlight on the last feature or note in the data file, the default search direction is Backwards. If you have re-positioned the highlight at or near the top of the data file, you may wish to change the direction to Forwards.

When you have entered a pattern and a direction, press . The search will commence from the currently highlighted feature or note. Asset Surveyor searches through each feature and note in turn, comparing the specified *Pattern* to each feature name, attribute value and note. Any partial match will result in Asset Surveyor highlighting the feature or note in which the match was found, and halting the search:

```

Review <<R100509a>>
1:          Logging started ...
2:
3:          Gas station
4:          Bank
5:          Highway
6:          Car park
SEARCH  POS  DEL  UNDEL

```

If Asset Surveyor searches right to the beginning of the data file (or the end, if the search direction is forwards) without finding a match for the pattern, it pops up the following message:

```

Error!
Not found:
"Memphis".

```



Note – When searching, Asset Surveyor only requires a partial match, and you do not need to specify the case of the pattern correctly. For example, a pattern of 'pot' will match attribute values like 'Pottsville' and 'spotted'.

Press again to continue the search, or to change the pattern or direction and search again.



Note – Asset Surveyor will not search for a match in any deleted features or notes.



Tip – Searching Asset Surveyor's database can take quite some time, especially if the features you have captured each have many attributes. If you decide not to continue with a search which has been running for a while, press (Esc) to abort the search.

Other Operations/ Review/ Positions

In the list of features and notes for a data file, you can view the GPS position(s) recorded for a feature by highlighting it and pressing

POS



Note – Unless you have used an RTCM link to differentially-correct your GPS positions in real time, or have used a P(Y)-code receiver, the positions displayed by Asset Surveyor will be subject to the effects of Selective Availability (SA).

Point Features

If you press **POS** when a regular point feature is highlighted, Asset Surveyor averages the GPS positions recorded for the feature and displays the averaged position:

Averaged position	
Feature:	
North:	5742788.71m
East:	2479065.09m
Alt (MSL):	381.27m
Datum:	NZGD 1949
Zone:	UTM Zone 59
WAYPT	OFFSET

If the point feature was recorded as a quickmark, Asset Surveyor displays the interpolated position for the feature:

Quickmark position	
Feature:	
North:	5742796.86m
East:	2479062.88m
Alt (MSL):	382.01m
Datum:	NZGD 1949
Zone:	UTM Zone 59
WAYPT	OFFSET

Line Features

If you press **POS** when a line feature is highlighted, Asset Surveyor asks you to specify whether you wish to see the start or end position for the line feature:

```

Which position?
End of line
  
```

Once you have chosen either the start or end position of the line, Asset Surveyor displays that position, for example:

```

                Start of line
Feature:
North:          5742804.07m
East:          2479065.37m
Alt (MSL):     381.26m
Datum:         NZGD 1949
Zone:          UTM Zone 59
WAYPT  OFFSET
  
```

Area Features

If you press **POS** when an area feature is highlighted, Asset Surveyor asks you to specify whether you wish to see the start, centroid or end position for that area feature:

```

Which position?
Start of area
End of area
  
```

Once you have chosen one of these three positions, Asset Surveyor display that position, for example:

Centroid of area	
Feature:	
North:	5742877.58m
East:	2478978.38m
Alt (MSL):	360.52m
Datum:	NZGD 1949
Zone:	UTM Zone 59
<div style="display: flex; justify-content: space-around;"> WAYPT OFFSET </div>	

Waypoints from Features

Each of the above forms which displays a particular position supplies a **WAYPT** softkey. You can press **WAYPT** to create a waypoint from the displayed position (and therefore a waypoint can be created for a particular feature):

Create waypoint 8	
Name:	
North:	5742877.58m
East:	2478978.38m
Alt (MSL):	60.52m
Datum:	NZGD 1949
Zone:	UTM Zone 59



Tip – By creating a waypoint for a feature, you can navigate back to that feature at a later date. You can also create a waypoint for a feature in Pathfinder Office after the feature's GPS position has been differentially corrected by postprocessing, and then load this waypoint back into the TDC2.



Note – Asset Surveyor provides the type of feature as a suggested name for the waypoint, but you will probably want to enter a new name which identifies the feature more precisely.

Other Operations/ Review/Positions/ Offsets

Each of the position forms which can be accessed to view the GPS position of a feature contains an **OFFSET** softkey. You can press this softkey to view and/or edit the offset for this feature.



Note – If a feature has a non-zero offset then the position(s) displayed for that feature will have the feature's current offset applied to it. **All** features have an associated offset, but by default (and typically) this offset will be zero.

Point Feature Offsets

If you press **OFFSET** when viewing the position of a normal, carrier phase or nested point feature, Asset Surveyor displays the current offset for that feature, for example:

Point offset	
Bearing:	
Slope dist:	6.230m
Inclination:	0.0°
RESET	FORMAT

You can simply view this offset, or you can edit it if you wish.



Note – Asset Surveyor lets you record a new offset for this point feature automatically using a laser rangefinder, provided you have activated the laser rangefinder interface (i.e. via the *External sensors* entry in the *Utilities* menu, or via the **EXT** softkey in data capture). You must be viewing the feature's offset form when you record the new offset. If you are not, then Asset Surveyor will apply the newly recorded offset to the feature which is currently being **captured**, if any.

Quickmark Offsets, Line Offsets and Area Offsets

If you press **OFFSET** when viewing a position for a quickmark, line (start or end) or area (start, centroid or end) feature, Asset Surveyor displays the current offset for that position, for example:

Line offset	
Direction:	
Slope dist:	3.500m
Inclination:	-2.3°
RESET	FORMAT

You can simply view this offset, or you can edit it if you wish.

Using a Laser to Update Offsets when Reviewing Data

When reviewing a data file, you can view and/or edit the offsets associated with each feature. You can use a laser rangefinder to update the offset associated with a feature using the following procedure.

To update an offset associated with a feature

1. Activate the laser rangefinder under the *External sensors* entry in the *Utilities* menu and then review the file.

You must review the data file in a context where the laser rangefinder interface can be activated in order to use a laser rangefinder to update a feature's offset.

2. Highlight the feature whose offset you wish to update in the review list. For example:

```

Review <<R100509a>>
1:                               Logging started:..
2:                               Town
3:                               Gas station
                               Bank
5:                               Highway
6:                               Car park
SEARCH  POS  DEL  UNDEL

```

3. Press **POS** to display the *Position* review form for that feature.

If the feature is a line, Asset Surveyor will require you to select the start or end of the line. If the feature is an area, Asset Surveyor will require you to select the start, centroid or end of the area. For the purposes of updating the feature's offset, it does not matter which of the feature's positions you choose to view.

For example, the *Position* review form for the *Bank* feature might be as follows:

Averaged position	
Feature:	Bank
North:	5742788.71m
East:	2479065.09m
Alt (MSL):	381.27m
Datum:	NZGD 1949
Zone:	UTM Zone 59
<div style="display: flex; justify-content: space-around;"> WAYPT OFFSET </div>	

4. The *Position* review form features an **OFFSET** softkey. Press this softkey to view and/or edit the offset for the feature. For example:

Point offset	
Bearing:	
Slope dist:	6.230m
Inclination:	0.0°
<div style="display: flex; justify-content: space-around;"> RESET FORMAT </div>	

5. Provided the laser rangefinder interface has been previously activated (as described in step 1), you can now record an offset with the laser and this will become the new offset for the feature.



Note – When using a laser rangefinder to update the offset for a line, area or quickmark feature, you will have to enter a value for the *Direction* field manually.

6. Press **OK** to save the modified offset.



Caution – You must take care to return to the **exact** position from which you first recorded the feature's position (with GPS). It will often be safer to re-record the feature in its entirety (and delete the previously recorded feature) than to try and remember exactly where you stood when you first recorded the feature's offset.

Other Operations/ Review/ Deleting and Un-deleting

Deleting Features and Notes

You can delete a feature or a note by highlighting it and pressing **DEL**. Asset Surveyor asks you to confirm your intention:

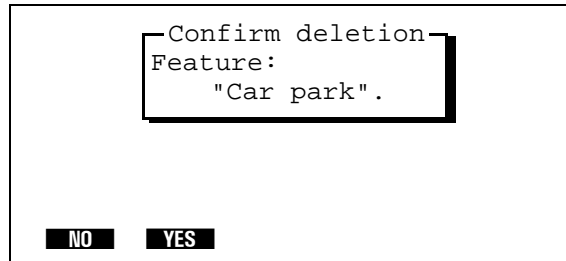

When a feature or note is deleted from an Asset Surveyor data file, it is not physically deleted. It remains in the file and can be un-deleted. A deleted feature or note will still be output to Pathfinder Office when the data file is transferred, and will appear in the resulting SSF file (where it will also be marked 'Deleted'). Pathfinder Office will not display deleted features or notes, and they will not appear in any GIS output.

When a feature is deleted from an Asset Surveyor data file, it appears in the review list as `***Deleted Point**`, `***Deleted Line**`, `***Deleted Area**` or `***Deleted Qmark**`. Similarly, a deleted note appears as `***Deleted note**`.

Un-Deleting Features and Notes

Because deleted features and notes are not physically removed from an Asset Surveyor data file, you can reverse the deletion process. You can un-delete a feature or note by highlighting it and pressing **UNDEL**.

Once a feature or note has been un-deleted, it is as if it had never been deleted in the first place. The feature or note will be treated by both Asset Surveyor and Pathfinder Office as a normal feature or note, and can be displayed and exported to a GIS.

A Troubleshooting

This appendix provides solutions to problems which may arise.

Table A-1 Troubleshooting

Symptom	Possible Cause	Fix
The receiver has not acquired a satellite within three minutes of the TDC2 being switched on.	The receiver is still looking for satellites.	Check the <i>GPS Satellite Info</i> screen to see how many satellites are being tracked by the receiver.
	The expected satellites are being obstructed.	The obstruction may be a building, tree, large vehicle, etc. Identify the obstruction and move away from it. <i>Note: GPS will not work indoors!</i>
	Your GPS receiver's external antenna (or antenna cable) has not been connected, has been connected incorrectly, or is faulty.	Check that the external antenna is connected correctly. If your receiver still fails to acquire signals from a satellite then your antenna and/or antenna cable may require servicing.
	Your GPS receiver requires an almanac to be loaded from the TDC2, but Asset Surveyor has not yet recorded an almanac and stored it on the TDC2.	Wait (for up to 15 minutes) until the GPS receiver records an almanac and makes it available to Asset Surveyor. Asset Surveyor will record the almanac and store it on the TDC2. It will be re-loaded into your GPS receiver when you next turn the TDC2 on.

Table A-1 Troubleshooting (Continued)

Symptom	Possible Cause	Fix
	<p>You have traveled a large distance (> 1000 km) since using the GPS receiver, and you have not re-configured the <i>Initial position</i>.</p>	<p>Reconfigure the <i>Initial position</i> under <i>Configuration / GPS / Rover options</i>, then turn the TDC2 off and on again to reinitialize communications with the GPS receiver.</p>
	<p>The receiver has not been used for a very long time, and an extreme change in the GPS constellation has out-dated the almanac stored in the receiver and/or the TDC2.</p>	<p>Wait (for up to 15 minutes) until a new almanac has been recorded. Subsequent restarts should then be rapid.</p>
<div data-bbox="162 821 351 972" style="border: 1px solid black; padding: 5px; width: fit-content;"> <p>No GPS detected Check cabling, batteries, etc. Do you wish to retry GPS now?</p> <p><input type="checkbox"/> NO <input type="checkbox"/> YES</p> </div> <p>appears on the TDC2.</p>	<p>The cable connecting the TDC2 to the GPS receiver has not been connected, or has been connected incorrectly, or is faulty.</p>	<p>Check that the cable is connected correctly. If it appears to be correct and all other equipment appears to be correct, the cable may require servicing.</p>
	<p>The GPS receiver's battery is dead, or has not been connected correctly.</p>	<p>Check that the battery is correctly connected, and is charged, or connect to an external power source.</p>
	<p>The GPS receiver has not been switched on.</p>	<p>The Series 4000, Centurion and Trimpack III GPS receivers must be manually turned on before Asset Surveyor can communicate with them.</p>

Table A-1 Troubleshooting (Continued)

Symptom	Possible Cause	Fix
The receiver is not able to compute a GPS position within one minute of you turning the TDC2 on.	There are not enough satellites available. <i>Three SVs are required in 2D mode, four SVs in 3D mode and five SVs in overdetermined 3D mode.</i>	Use mission planning to check that there are sufficient satellites at this time.
		Under <i>GPS Rover options</i> and/or <i>Base stn options</i> , check that the <i>Elevation mask</i> is not too high.
		Under <i>GPS Rover options</i> and/or <i>Base stn options</i> , check that the <i>SNR mask</i> is not too high.
		Under <i>GPS Rover options</i> and/or <i>Base stn options</i> , check that the <i>Position mode</i> is correct.
	The current PDOP value is too high.	Use mission planning to check that the current PDOP value is below your configured mask.
Under <i>GPS Rover options</i> and/or <i>Base stn options</i> , check that the configured <i>PDOP mask</i> and <i>PDOP switch</i> are not too low.		
The TDC2 will not turn on, or turns off immediately after being turned on.	The main TDC2 batteries are dead.	Replace or recharge the main TDC2 batteries, or power the TDC2 externally.
	The Asset Surveyor software has locked up.	Perform a reboot of the TDC2, as described in section 2.3, page 2-3. If the problem recurs, contact your Trimble Assistance Center.

Table A-1 Troubleshooting (Continued)

Symptom	Possible Cause	Fix
The display on the TDC2 is dim, or washed-out.	The TDC2's LCD contrast needs adjusting.	Adjust the LCD contrast as described in Chapter 2.
	The main TDC2 batteries are low.	If the battery level is low, replace or recharge the batteries.
TDC2 screen goes black	Has been sitting in direct sunlight.	Remove from direct sunlight and wait until the screen returns to normal.
The TDC2 does not accept a scanned barcode.	The barcode wand has not been connected correctly.	Connect the barcode wand correctly, as described in section 2.11, page 2-13.
	The barcode is unreadable. The barcodes may be printed at the wrong size or with a low-quality printer. The barcodes may have been photo-reduced or smudged.	Reprint the barcodes. Refer to the Pathfinder Office documentation for details of barcode printing options.
	The barcode is inappropriate in the current context.	You can only swipe a menu value when capturing a feature of the correct type. You can only swipe a feature name when a menu of features is displayed.

Table A-1 Troubleshooting (Continued)

Symptom	Possible Cause	Fix
	The angle of the wand is wrong, or the barcode was swiped too quickly or too slowly.	Change the angle at which you swipe the barcode. Move the wand smoothly across the barcode. Vary the speed at which you swipe the barcode. Try re-printing the barcodes at a larger size.
The accuracy of recorded GPS positions is not as good as you expect.	You did not record sufficient positions to achieve the required accuracy (for a point feature).	For some GPS receivers, Trimble specifies that a certain minimum number of GPS positions be logged, differentially corrected and averaged to achieve a required level of accuracy for point features. You should configure the <i>Minimum posns</i> option (under <i>GPS Rover options</i>) to ensure that Asset Surveyor records enough positions to meet your accuracy requirements.
	You may be operating in an area of high multipath	Move to a better area of GPS coverage and use offsets.
	Your <i>PDOP mask</i> was too high.	If you record positions when the PDOP is high (i.e. the geometry of the GPS satellite constellation is poor), this will have a detrimental effect on the accuracy of these positions. You should lower your <i>PDOP mask</i> to ensure that Asset Surveyor only logs accurate positions.

Table A-1 Troubleshooting (Continued)

Symptom	Possible Cause	Fix
	Your <i>SNR mask</i> and/or <i>Elevation mask</i> was too low.	The GPS receiver will select the satellite constellation with the best geometry (i.e. the lowest PDOP). This tends to mean that satellites low in the sky are chosen, but the closer a satellite is to the horizon the weaker its signal is. You should increase the <i>SNR mask</i> and/or the <i>Elevation mask</i> to preclude the use of satellites whose signals are weak.
	You used a 2D mode and failed to specify an accurate 2D altitude.	The accuracy of 2D GPS positions is critically dependent on the quality of the 2D altitude you supply. You must specify your altitude precisely in order to use a 2D mode and still obtain accurate GPS positions. You must also specify the 2D altitude relative to the correct reference level (i.e. mean sea level or the current ellipsoid)
Your RTCM real-time differential correction link does not appear to work.	Your telemetry link has been incorrectly installed, powered, cabled or configured.	Install the telemetry link as specified by the supplier. Consult the supplier if necessary.
	You have configured the RTCM serial parameters incorrectly.	Under <i>GPS Rover options</i> , press the RTCM softkey and check that the RTCM serial parameters match the telemetry link and the transmitted RTCM data stream.

Table A-1 Troubleshooting (Continued)

Symptom	Possible Cause	Fix
	You have set the RTCM version or RTCM station ID incorrectly.	Under <i>GPS Rover options</i> , press the RTCM softkey and set the <i>RTCM version</i> and <i>RTCM station</i> fields correctly.
	You have set the RTCM input mode to Off.	Under <i>GPS Rover options</i> , press the RTCM softkey and set the <i>RTCM input mode</i> to either On (which requires RTCM to always be present) or Auto (which allows RTCM to be present or absent).
Your integrated MSK Beacon receiver does not appear to work (Pro XR and Pro XRS only)	You have set the <i>Source</i> incorrectly.	Under <i>Integrated DGPS</i> , set the <i>Source</i> field to Off.
	You have set the <i>Frequency</i> incorrectly.	Set the frequency to the correct number, or configure the <i>Mode</i> field to <i>Auto range</i> or <i>Auto power</i> to allow the receiver to select the beacon.
Your integrated Satellite receiver does not appear to work (Pro XRS only).	You have set the <i>Source</i> incorrectly.	Under the <i>Integrated DGPS</i> set the <i>Source</i> field to Off
	You have set the <i>Provider</i> field incorrectly.	Under <i>Integrated DGPS</i> , set the <i>Provider</i> field to the appropriate service.

Table A-1 Troubleshooting (Continued)

Symptom	Possible Cause	Fix
	You have not enabled your integrated Satellite receiver.	Refer to the <i>ProXR/XRS Receiver Manual</i> for further details of how to enable your integrated Satellite receiver.
You are unable to differentially correct your rover GPS positions (either in real-time or when postprocessing).	The GPS rover used satellites which were not visible to the GPS base station.	Ensure that the <i>Elevation mask</i> on the GPS rover is set sufficiently high that the rover will only use satellites which are also visible to the GPS base station.
The coordinates displayed by Asset Surveyor appear to be incorrect.	You are using the <i>Latitude/Longitude</i> coordinate system and have selected the wrong datum.	Under the <i>Coordinate system</i> configuration menu, select <i>Latitude/Longitude</i> and specify the correct datum.
	You are using the <i>UTM</i> coordinate system and have selected the wrong UTM zone or datum.	Under the <i>Coordinate system</i> configuration menu, select <i>UTM</i> and specify the correct zone and datum. <i>Note: The traditional UTM datum for the U.S.A is NAD-27.</i>
	You have selected the wrong coordinate system or zone.	Under the <i>Coordinate system</i> configuration menu, select the correct coordinate system and zone.
	You have selected the wrong coordinate units.	Under the <i>Units and display</i> configuration menu, select the correct <i>Coords</i> units.

Table A-1 Troubleshooting (Continued)

Symptom	Possible Cause	Fix
	You have defined a custom coordinate system, datum and/or zone incorrectly in ASSETED.	Check the definition of the coordinate system, datum and/or zone carefully. Ensure that values such as the scale factor have been specified correctly (as a parts-per-million value), that rotations have been specified in the correct sense (a positive rotation is counter-clockwise), and that Latitudes and Longitudes have been specified in the correct hemisphere (North/South or East/West, respectively).
Automatically-generated <i>Time</i> attributes are incorrect	The TDC2's internal clock has been set incorrectly.	Reset the TDC2's internal clock (under the <i>Time and date</i> configuration menu entry). Check that the <i>24-hour clock</i> field is set correctly.
The Asset Surveyor software does not communicate with an external sensor.	The sensor has not been connected, or has been connected to the wrong serial port, or the cabling is faulty.	Connect the sensor correctly. Check that the cabling is appropriately wired.
	The configured external sensor has the wrong RS232 settings.	Check the configuration of the RS232 settings for that sensor (press COMMS in that sensor's configuration form).



Table A-1 Troubleshooting (Continued)

Symptom	Possible Cause	Fix
	The configured sensor has the wrong <i>Data request</i> string, the wrong <i>Data received</i> settings, or the <i>Interval</i> fields are None.	Check that the configuration matches the requirements and specifications of the sensor in question.
Offsets recorded with a laser rangefinder seem inaccurate.	You have not made allowance for the local magnetic declination.	In the <i>Units and display</i> form, enter the correct local magnetic declination into the <i>Magnetic decl</i> field.
	Your laser is attempting to apply its own magnetic declination, in addition to Asset Surveyor's.	Configure the laser to output uncorrected magnetic bearings only.
	The environment in which you are working is magnetically 'hostile', and is affecting the laser's compass.	Move away from all ferrous metal objects (e.g. vehicles, buildings, bridges, overhead cables, etc.). Calibrate the compass of your laser rangefinder, if possible.
Asset Surveyor fails to communicate with a laser rangefinder.	Your cabling is faulty and/or incorrectly connected.	Check the cabling.
	Your laser is configured incorrectly for operation with Asset Surveyor.	Configure the laser, if possible, as outlined in Chapter 5, Configuring the Asset Surveyor Software.
	Asset Surveyor has not been configured to work with your laser.	Select <i>External sensors</i> from the <i>Utilities</i> menu. Highlight the <i>Laser</i> entry and press SETUP . Select from the list of supported laser rangefinders.

B Asset Surveyor Messages

This appendix lists, in alphabetical order, the various error, warning, and information messages which are displayed by the Asset Surveyor software. The cause(s) of each message is described, and suggestions of how to proceed are supplied where relevant.



Note – Error messages (which have the word 'Error!' as their title) remain on the TDC2s screen until you press . Warning messages usually time out after four seconds and disappear, but can also be dismissed by pressing .

\XX escape sequence is invalid

You have entered an invalid hexadecimal code into a field in the External Sensor configuration form. Each escape sequence must consist of a backslash ('\') character, followed by two hexadecimal digits.

To enter the backslash character itself into a field, type the following escape code: '\5C'.

4000 battery is low

The battery currently being used by the connected Series 4000 GPS receiver is low. A Series 4000 receiver can be connected to several batteries at once, and will emit the '4000 battery is low' message even if one or more batteries remain fully or partially charged. If the receiver is currently using its last battery, you should change or recharge the receiver's batteries as soon as possible after seeing this message.

4000 Nav. firmware needs upgrading

This message is displayed if the Navigation firmware in the connected Series 4000 GPS receiver is older than version 5.64. This is the earliest version of the Series 4000 receiver firmware which works with the Asset Surveyor software.

Contact your Trimble Assistance Center to obtain an upgrade to the firmware in your Series 4000 GPS receiver.

A file with this name exists. Do you wish to append to it?

This message appears in *Base station* mode, when you attempt to create a new base station file with the same name as a previous data file. Press **YES** if you wish to append base station data to the end of the existing data file or press **NO** if you wish to create a new base station file with a different name.

A NOTE may only be recorded during data capture

This error message appears if you press outside of *Data capture*. You can only record a note when capturing data to a rover file.

Abandon changes?

This message warns you that changes you have made to a form will be lost if you continue. It is displayed if you press on a form after changing the value of one or more fields. If you want to save changes to the form, press **NO**, followed by , otherwise press **YES** to abandon the changes.

Abandon feature?

This message appears if you press on the attribute entry form for a feature in *Data capture*. Press if you wish to abandon the feature. If you want to save the feature, press followed by .

If you abandon a feature, its attributes, GPS positions and any associated ESP data will be discarded by Asset Surveyor, and cannot be recovered.

Activation complete

This message will appear when the DGSP satellite has confirmed that your Pro XRS receiver has the appropriate activation to receive RTCM corrections using the integrated DGPS satellite component of the receiver.

An error was detected in the Pathfinder GPS receiver

An internal diagnostic inside the connected Pathfinder GPS receiver has detected an error. Try disconnecting the receiver from its power supply and/or removing any batteries, wait for a few minutes for any internal capacitance to discharge, then reconnect the receiver and try using it again. If the above message reappears, contact your Trimble Assistance Center.

Are you sure you want to disconnect from GPS?

This message is displayed when you select the *Disconnect* entry from the *GPS operations* menu. Press if you want Asset Surveyor to cease communicating with the currently connected GPS receiver, or press if you want to continue using the GPS receiver.

When a GPS receiver is disconnected, Asset Surveyor will turn the receiver off if it is able to. If not, you should manually turn off the receiver to avoid draining its batteries. If the connected GPS receiver is a Series 4000 receiver, remember to turn the receiver back on before attempting to re-establish communications with Asset Surveyor.

Best results are obtained by using a receiver with 12 channels

If you start a base station file with an 8-channel Pro XL or Pro XR receiver connected, Asset Surveyor warns you that you will obtain better results using a 12-channel receiver. If you wish to upgrade an 8-channel Pro XL or Pro XR to 12 channels, or to a Pro XRS, contact your Trimble Assistance Center for up-to-date pricing details.

Cannot quickmark when logging is paused

This message will be displayed if you press **QUICK** to record a quickmark when logging is paused. The quickmark is not recorded. You will have to return to the position of the feature you tried to quickmark and re-record the feature after resuming logging of GPS positions.

If you want to record a point feature which lies off a line feature or off the perimeter of an area feature, you cannot record the feature as a quickmark (without inserting a spike in the line or area feature), unless you use an offset. It is usually easiest to use the **NEST** softkey to record point features lying off a line or area feature.

Cannot specify units in a unitless domain

This message is displayed if you type any non-numeric characters (apart from sign characters) into a numeric field which does not permit units to be specified.

Carrier lost XX:XX

This message appears on the status line when the receiver has lost lock on the minimum number of satellites required for carrier phase data collection. The time displayed indicates the amount of carrier data that had been logged since the previous loss of carrier information.

Carrier mode is off

This message appears on the GPS status line when you start a file and carrier phase mode is disabled.

Carrier mode is on

This message appears on the GPS status line when you start a file and carrier phase mode is enabled.

Carrier stated

This message appears on the GPS status line when a complete carrier phase message is received after the carrier time has been reset.

XX:XX Carrier time

This message displays whenever carrier data is logged and informs you of the amount of carrier data that has been logged since the last time this counter was reset due to a loss on satellite lock.

Checking activation

This message appears on the status line when you have configured the Pro XRS receiver to receive RTCM corrections using the DGPS satellite component of the receiver. It may take up to ten minutes for the DGPS satellite component to receive confirmation from the satellite that your receiver is activated to receive these corrections.

Clear waypoints file, deleting all current waypoints?

The **CLEAR** softkey on the waypoints menu deletes all waypoints stored on the TDC2. This message is displayed when you press **CLEAR** to avoid the accidental deletion of all waypoints. Press **YES** to actually delete the waypoints or **NO** to return to the menu of waypoints.

Communications error

This error message indicates a break-down in communications between Asset Surveyor and an external sensor. This may be caused by incorrect or damaged wiring in the cable between Asset Surveyor and the sensor, or the sensor operating in an incorrect mode. Check that the communications parameters (under the **COMMS** softkey, from the external sensor configuration form) are set correctly.

This message may also appear if an external sensor emits data at such a rate that the TDC2 cannot process the incoming data fast enough to avoid a serial buffer overrun. In this situation, part or all of an incoming data record may be lost. If it is critical that the datalogger be able to log every record emitted by the sensor, it may be necessary to run the sensor at a slower rate.

Confirm deletion

Whenever you attempt to delete a data file, data dictionary, waypoint, coordinate system, datum, zone or language file, Asset Surveyor will ask you to confirm that it really is your intention to delete the indicated item. Press **YES** to delete the item or **NO** to indicate that you either selected the delete operation by mistake, or have decided not to delete the item.

Connect antenna/cable

This message appears on the GPS status line if Asset Surveyor detects that the receiver's antenna and/or cable is disconnected, improperly connected or faulty.

Connect cable to PC

This message is displayed when you select *File transfer* from the Asset Surveyor software's *Main menu*. It serves as a reminder to connect the TDC2 to the PC before attempting to transfer files between the two using Pathfinder Office.

Constant offset(s) are active

Whenever you create a new rover file or re-open an existing file, Asset Surveyor checks to see if you had previously configured one or more constant offsets. If you had, Asset Surveyor warns you by displaying the 'Constant offset(s) are active' message. If you do not wish to apply constant offsets to features which you record, select *Constant Offsets* from the *Configuration* menu and **RESET** all of the configured offsets to zero.

Corrupt data dictionary file

Asset Surveyor has detected an error in the current data dictionary that you are using. Delete that data dictionary and try re-loading it from Pathfinder Office to your TDC2. If the problem persists, contact your Trimble Assistance Center for assistance.

Data dict. cannot be deleted until files using it are deleted first

When you press **DEL** on the menu of data dictionaries, Asset Surveyor checks that there are no data files on the TDC2 which are associated with this data dictionary. If one or more data files require(s) this data dictionary, the above message will appear and you will not be permitted to delete this dictionary. You must transfer the data files concerned to Pathfinder Office and then delete these data files from the TDC2 before you will be permitted to delete this data dictionary. The *File statistics* screen shows which data dictionary is used by the selected data file.

DD read OK

This message is displayed on the *File transfer* status form when a data dictionary has been transferred from Pathfinder Office to the TDC2, and Asset Surveyor has verified that the data dictionary was transferred correctly and has been successfully stored on the TDC2.

Delete failed

An attempt to delete a data file has failed. This may be caused by a corrupted file system or faulty datalogger memory. Contact your Trimble Assistance Center for assistance.

Directory sent

This message appears on the *File transfer* status form, and indicates that Asset Surveyor has transmitted a directory of data files to Pathfinder Office.

Disconnect GPS before selecting this option

This message is displayed if you select the *File transfer* or *Upgrade software* menu entry when the GPS receiver is still connected to (and communicating with) Asset Surveyor.

You must physically disconnect the GPS receiver before attempting to perform one of these operations, as they use the same TDC2 serial port as the GPS receiver. Select *Disconnect* from the *GPS operations* menu, or simply unplug the GPS receiver and wait until Asset Surveyor detects that the receiver is no longer present.

Do you want to delete all files?

When you press **DELALL** on the *Delete file* menu, Asset Surveyor asks you to confirm that you wish to delete all data files. You will be asked to reconfirm deletion for any file(s) which have not yet been transferred to the PC.

Doing fixes

This message appears in the *Status* field of the *Receiver status* form when connected to a GPS receiver which is currently computing GPS positions (i.e. is tracking sufficient satellites, with a PDOP lower than the configured mask).

Downloading file

This message is displayed during stage 1 of the *Upgrade* procedure, when upgrading the TDC2 to a new version of the Asset Surveyor software.

Duplicate data dictionary name not allowed

Asset Surveyor has just received a new data dictionary from Pathfinder Office. However, the data dictionary name is identical to the name of an existing data dictionary on the TDC2. Delete the old data dictionary from the TDC2 before re-transferring the new dictionary.

Duplicate file names are not allowed

Asset Surveyor insists that all data files have unique names. This message is displayed if you attempt to create a new rover data file with the same name as an existing data file. The case (upper or lower) of a letter in a file's name is ignored when comparing two names for equivalence.

Entry required

If, when you create a Data Dictionary in Pathfinder Office, you specify *Entry Required* for an attribute of a feature, Asset Surveyor will not allow you to save a feature of that type without entering a value for that attribute. If you press on an attribute entry form when one or more attributes with the *Entry required* flag still have the null value, Asset Surveyor will display this error message and direct you to the first attribute requiring an entry.

Error closing file

Asset Surveyor encountered an error when attempting to close a file. This may indicate a corrupt file system or faulty datalogger memory. Contact your Trimble Assistance Center for assistance.

Error opening data dictionary

Asset Surveyor is unable to open a data dictionary for use in association with a particular data file. It is possible that the data dictionary has become corrupted, and you should try deleting that dictionary and again transferring it from Pathfinder Office to the TDC2.

It is also possible that there is too little data storage space remaining on the TDC2 to open and cache the data dictionary. In this case, try deleting one or more unwanted data files.

If the problem persists, contact your Trimble Assistance Center for assistance.

Exit data capture?

This message is displayed whenever you press **Esc** to exit *Data capture*. Press **YES** to exit data capture, or press **NO** to return to the menu of features to capture.

Exit from data capture or file transfer before switching off

You have tried to turn the TDC2 off while inside *Data capture* or *File transfer*. You must complete the current operation and exit *Data capture* or *File transfer* (by pressing **Esc**) before attempting to turn the TDC2 off.

File error

An error has occurred while Asset Surveyor was performing a file-related operation (e.g. reading a file, writing a file, creating a new file, etc.).

This message may occur when Asset Surveyor attempts to write to a data file and the TDC2's data storage memory is full. In this case, you should press any key to restart Asset Surveyor and then download and delete sufficient data files before continuing to capture data.

First and second parallels are equal

This message is displayed by the ASSETED utility. You have entered the same latitude for the first and second parallel when defining a coordinate system zone using the '2-Parallel Lambert' map projection. Re-enter one or both of the 'parallel' latitudes for the zone with the correct values.

Floating point number too large

A numeric value which you have entered into a field is too large to be stored or displayed by Asset Surveyor.

Asset Surveyor can store and display quite enormous numeric values. When this message is displayed, it usually means that you have just miss-typed a value, or possibly that you have entered a coordinate using an inappropriate coordinate system (which cannot mathematically represent the point entered).

GPS in 2D mode

This message is displayed when a GPS receiver is connected and operating in the *Auto 2D/3D* position mode, and the receiver switches from computing 3D GPS positions to computing 2D GPS positions.

Inaccurate UTM zone. Recalculate the zone from GPS?

The UTM zone that you have entered is at least two zones (i.e. 12° of longitude) away from your most recent GPS position. Press **NO** if you still want to save this zone. If you want Asset Surveyor to ‘guess’ the correct UTM zone, press **YES** and the GPS receiver will use your most recent GPS position to automatically calculate the UTM zone.

Inappropriate for feature

You have scanned a barcode for an attribute that does not belong to the feature currently being captured. Check that you are using the correct page of barcodes.

Asset Surveyor can distinguish between identical values for different attributes (e.g. the attribute value ‘Gold’ for the color of an automobile is distinct from the attribute value ‘Gold’ for the type of metal found in a particular mine).

Inappropriate location for map projection

You have entered a coordinate (North / East) which is outside the bounds of the currently selected coordinate system zone. Check that you have selected the appropriate coordinate system and zone. Check that you have entered the coordinate correctly (paying particular attention to signed values). If you are using a custom coordinate system and/or zone, check that you have defined the coordinate system, datum and/or zone correctly.

Incorrect receiver type for base stations

This message appears if you select the *Base station* entry from Asset Surveyor's *Main menu* while connected to a Series 4000 GPS receiver. Only Pathfinder GPS receivers can be used in base station mode in conjunction with the Asset Surveyor software.

Insufficient carrier data; do you want to close this file now?

This question appears if you try to close a file in carrier phase mode before the configured *Minimum time* has elapsed. Press **YES** to close the file, or press **NO** and wait until Asset Surveyor has recorded enough carrier phase data before closing the file.

Insufficient GPS positions: do you want to store this feature now?

You have pressed to store the details for the current point feature before Asset Surveyor has had time to record the required (*Minimum posns*) number of GPS positions. Press **YES** to store the point feature, or press **NO** and wait until Asset Surveyor has recorded enough positions before pressing again.

Internal error

An unexpected error has occurred in the Asset Surveyor software. Record the current contents of the TDC2's screen and contact your Trimble Assistance Center for assistance.

Invalid date

The date you have entered is invalid. Check that you have entered the date in the correct format (subject to the *Date fmt* field in the *Time and date* configuration form).

Invalid file or version

A file on your TDC2 has an invalid version number or corrupted contents. Be careful not to mix files from different versions of the Asset Surveyor software. If the problem persists, contact your Trimble Assistance Center for assistance.

Invalid time

The time you have entered is invalid. Remember to enter the time as up to three values separated by a space or a colon. You can enter times in either the 12- or 24-hour clock format. If you are entering times using the 12-hour clock, remember to specify pm if the time is after midday. You can configure the way in which times are displayed in the *Time and date* configuration form.

Invalid units

The unit you have entered is not permitted in the context of the field into which it was typed. Specify the correct units (by pressing the **UNITS** softkey if necessary).

If you type an alphabetic character into a numeric field by mistake, Asset Surveyor will mistake it for a units designator. Edit the field and remove the spurious alphabetic character.

Invalid user code: Please try again or contact your service provider

You have entered an invalid user code for the OmniSTAR DGPS satellite correction activation. You should check that the user code you entered is correct. If it is not, contact your local service provider for details.

Laser offsets can only be recorded for features

You attempted to record a laser offset when you were not capturing a feature. Asset Surveyor only associates offsets with features, so you must start a feature before recording a laser offset.

Logging paused

When you press the **PAUSE** softkey while logging GPS positions for a point, line, or area feature, Asset Surveyor will display this message on the GPS status line. The message will continue to flash on the status line until you resume logging by pressing the **RESUME** softkey.

Maximum bytes includes the length of the prefix and suffix

The *Max bytes* record length you have specified while configuring an external sensor is less than the combined length of the prefix and suffix strings. Remember that the maximum record length *includes* the length of the prefix and suffix strings.

Memory nearly full

This warning message is displayed once a minute whenever there is less than 20 kb of data storage space left. If you are currently capturing data, free up some space by deleting old data files. You can select *File statistics* from the *Data capture* menu to determine how much space a data file is using.

Min. time achieved!

This message is displayed on the status line when the *Minimum time* for carrier phase data has been exceeded.

No almanac file available

This message is displayed on the TDC2 if you try to transfer an almanac file from the TDC2 to Pathfinder Office, and no almanac file exists on the TDC2.

Asset Surveyor will record an almanac from any Pathfinder GPS receiver which has an up-to-date almanac. If you have a Series 4000 GPS receiver, Asset Surveyor will not record an almanac from the receiver, but you can record an almanac by logging data to the receiver's internal memory and then extracting it as described in the *GIS Surveyor Operation Manual*.

No corresponding data dictionary

There is no corresponding data dictionary for a particular data file. This situation can only occur if part of the data storage memory of the TDC2 has been erased or corrupted. Contact your Trimble Assistance Center for assistance.

No END waypoint

This message is displayed whenever you are in a navigation form and have not selected a target waypoint to navigate to. To select an end waypoint press **END** and choose from the menu of defined waypoints.

No features found

If you capture data to a file whose associated data dictionary contains no features at all, this message will be displayed. You can still log GPS positions and ESP data from external sensors without any associated feature or attribute information.

This message is also displayed if you attempt to review a file which does not contain any features (e.g. a base station file).

No files

This message is displayed in place of the menu of available data files when the TDC2 does not contain any data files.

No GPS detected. Check cabling, batteries etc. Do you wish to retry GPS now?

You have either just turned the TDC2 on, or have pressed , and have not connected, powered or turned on your GPS receiver. If you do not wish to use GPS, press . If you wish to use GPS, check that the receiver is connected to the TDC2, that the receiver is connected to its batteries (which must be charged) and that the receiver is turned on (if it has an external power button) before pressing to retry the GPS connection.

If the Asset Surveyor software again fails to communicate with the GPS receiver, you may have a faulty cable, battery pack or receiver. Contact your Trimble Assistance Center to have your GPS equipment serviced.

No GPS positions for feature

This message is displayed when you press the softkey in data review and the currently highlighted feature has no recorded GPS positions.

No GPS positions recorded. Do you want to store this feature now?

You have pressed on an attribute entry form while connected to a GPS receiver, but no GPS positions have been logged for the current feature. The GPS receiver will only log positions if there are sufficient satellites and the PDOP is low enough. You should press and return to the attribute entry form before allowing the GPS receiver to record GPS positions for that feature. If you press , Asset Surveyor will save the attributes you have entered for the feature, but Pathfinder Office will ignore the feature entirely (unless you can process the resulting data in such a way as to ascribe a position to that feature).

No GPS time

The GPS receiver has not yet obtained GPS time from a GPS satellite.

No index file

This error message indicates that part of a data file has been erased or corrupted on the TDC2. Contact your Trimble Assistance Center for assistance.

No more files permitted

You have reached the maximum limit on the number of data files, data dictionaries and language files permitted on the TDC2. Transfer your data files to the PC and delete from the TDC2 any that are no longer needed.

No usable SVs

This message appears in the *Status* field of the *Receiver status* form when connected to a GPS receiver and the receiver is tracking no GPS satellites. In this situation, the receiver is unable to compute a GPS position. The GPS receiver may have an old, inaccurate or missing almanac, or the receiver's antenna may be obscured.

OLD Navigation

The heading of the *Navigation* form will change to *OLD Navigation* whenever a current GPS position is unavailable (e.g. when there are too few satellites, the PDOP is too high, or the RTCM link is down).

OLD Position

The heading of the *GPS Position* form will change to *OLD Position* whenever a current GPS position is unavailable (e.g. when there are too few satellites, the PDOP is too high, or the RTCM link is down).

Out of range

The value you have entered is outside the permitted range of values allowed for this field. Most numeric fields have tight bounds on the range of values that may be entered. The bounds on numeric attribute values are specified when a data dictionary is created using Pathfinder Office.

PDOP is too high

The current PDOP is higher than the configured *PDOP mask*, and the GPS receiver is no longer computing GPS positions. See Chapter 5, Configuring the Asset Surveyor Software in the *Mapping Systems General Reference* manual for a discussion of the effect of satellite geometry on the accuracy of GPS positions.

Please configure the current time and date

Asset Surveyor displays this message every five minutes if the TDC2's internal clock is set to a time or date which is known to be incorrect because it is set prior to the release date of the Asset Surveyor software. You can reset the TDC2's internal time and date in the *Time and date* configuration form.

Please delete all files before upgrading

When you select the *Upgrade software* option from the *Utilities* menu, Asset Surveyor checks that there are no data files remaining on the TDC2. All data files should be transferred to your PC and then deleted from the TDC2 before you try to upgrade to a new version of the Asset Surveyor software, as the upgrade procedure erases the entire contents of the TDC2's data storage memory.

Please supply the TDC2 with external power

The contents of the TDC2's non-volatile memory cannot be erased and re-programmed without external power being supplied. See the cabling description and diagram in Chapter 3.

Press OFFSET before using the laser

You attempted to record a laser offset while capturing a line or area feature. Asset Surveyor requires you to be viewing the *Offset* form for this feature are the time you record the laser offset (so that it can be sure that you remember to enter a value into the *Direction* field). The *Offset* form is accessible by pressing **OFFSET**.

Press RTCM to check other serial parameters

After configuring receiver outputs (under **OUTPUT**), Asset Surveyor will display this message to remind you that other serial communications parameters (i.e. data bits, stop bits and parity) are configured in the *RTCM input options* form, which you can access by pressing **RTCM**.

Quickmark position outside five second limit

When you press **POS** to review the position of a quickmark feature, Asset Surveyor will display the above message if the GPS positions which bracket the quickmark feature are not within 5 seconds of the quickmark. This will have occurred because GPS positions were unavailable just after the quickmark was recorded (e.g. due to insufficient satellites, high PDOP or RTCM link loss).

Recording almanac

Asset Surveyor is currently recording an up-to-date almanac from the connected Pathfinder GPS receiver. The almanac contains satellite orbital information which can be sent to the receiver at a later date to ensure rapid acquisition of satellites, and can also be transferred to the PC for use in Mission Planning.

Recording ephemeris

Asset Surveyor is recording the most up to date satellite information for a particular satellite (which has either just been acquired by the receiver, or has just transmitted updated ephemeris information). Asset Surveyor briefly stops recording GPS positions while it receives and logs the up-to-date ephemeris information. This information is crucial to high-accuracy differential correction.

When you start capturing data to a file, Asset Surveyor will record ephemeris information for all visible satellites. This takes a few seconds, after which GPS positions can be logged.

RTCM link lost

Real-time RTCM differential corrections are not being received by the GPS receiver, or have not been received for a period in excess of the configured RTCM *Warning time*. Check that the telemetry link is still attached to the GPS receiver, is turned on, and is still being powered. It is possible that the telemetry link has been obstructed (e.g. by a hill, a building or other physical obstructions), that the base GPS receiver or transmitter have ceased operating, or that your roving GPS receiver is using one or more satellites which are not visible to the base receiver.

Search aborted

You have interrupted an attribute value search in data review by pressing .

Searching...

Asset Surveyor is searching through a data file for a particular feature or attribute value.

Sending almanac

This message appears on the status line when Asset Surveyor loads a pre-recorded almanac into a GPS receiver, to ensure that the receiver acquires satellites quickly.

Sorry, GPS time required before creating a data file

Before Asset Surveyor will allow you to create a data file for the first time (since installation or since you last reset the memory of your datalogger), it must align the datalogger's clock with GPS time. You should connect your GPS receiver and allow Asset Surveyor to record a GPS time before again attempting to create a new data file.

Storing data

Asset Surveyor is busy storing data for the feature which is being saved.

Switching from P(Y)

You are connected to a Trimble Centurion or Trimpack III GPS receiver which has a P(Y) description key installed and enabled. Asset Surveyor is monitoring the receiver as it switches from P(Y) mode to C/A mode. This switch may take a few seconds, during which GPS positions will be unavailable.

Switching to P(Y)

You are connected to a Trimble Centurion or Trimpack III GPS receiver which has a P(Y) description key installed and enabled. Asset Surveyor is monitoring the receiver as it switches from C/A mode to P(Y) mode. This switch may take a few seconds, during which GPS positions will be unavailable.

The external battery is dead

When the battery voltage being supplied to your GPS receiver drops below a specified level, it may begin to operate unreliably or to suffer internal damage. To avoid such problems, Asset Surveyor will cease communicating with the connected GPS receiver, and will power the receiver off, if possible.

Table B-1 lists applicable GPS receivers and their threshold voltages. Other receivers have built-in protection from low voltages.

Table B-1 Receiver Voltages

GPS Receiver	Threshold Voltage
Pathfinder Pro XL	10.5 V
Pathfinder Pro XR	10.0 V
Pathfinder Pro XRS	10.0 V

The external battery is low

The external (GPS receiver) battery is low. You should complete your current operation as quickly as is practical, and then change the GPS receiver's batteries before pressing **[GPS]** to reactivate Asset Surveyor's GPS interface.

The internal backup batteries are dead

The lithium backup batteries are dead. These *must* be replaced immediately. Any loss of power to the TDC2 caused by the removal of the main internal battery will result in the loss of all data files, waypoints and data dictionaries stored on the TDC2. Make sure you connect to external power while replacing the backup batteries.

The main internal battery is low

This warning message is displayed every two minutes when the power in the main TDC2 battery is getting low. The battery should be replaced or recharged as soon as possible so that Asset Surveyor may continue to be used.

The P(Y) key is disabled. P-code positions will not be available

When connected to a Trimble Centurion or Trimpack III GPS receiver which has a P(Y) description key installed, Asset Surveyor has determined that the key has been disabled or has expired. C/A-code positions will be available, but P-code positions will not.

This datum is currently referenced by a coordinate system

This message is displayed by ASSETED when you try to delete a datum that is in use by a coordinate system. You must delete all coordinate systems which use a datum before the datum itself can be deleted.

This feature has not yet been captured

This message is displayed when you try to repeat a feature in 'Data capture' and a feature of that type has not yet been recorded to the current data file.

This file has not been transmitted to the PC

When you select a file from the *Delete file* menu, Asset Surveyor checks that the file has been output to Pathfinder Office. If not, it displays the above message. Press **YES** to delete the file if you really do not want to output it to the PC.

Timed out

Communications with an external sensor or GPS receiver has timed out unexpectedly. This occurs when Asset Surveyor receives only part of a data record from the sensor or receiver. Check that the cabling is still connected and that the sensor or receiver is still powered and turned on.

Too close to the equator

This message is displayed by the ASSETED utility. The latitude you have entered for the indicated parallel in the 1- or 2-Parallel Lambert map projection is too close to the equator. The Lambert Conformal map projections become distorted near the equator, and can cause computational difficulties, so ASSETED imposes a limit on the distance of the parallel(s) from the equator.

Too close to the north or south pole

This message is displayed by the ASSETED utility. The origin latitude that you have entered for a zone using a Mercator map projection is too close to either the North or South pole.

Too few SVs

There are insufficient satellites (SVs) to compute a GPS position. At least four satellites are required for a 3D position, and three for a 2D position. If you have configured Asset Surveyor to use the 'Overdet. 3D' position mode, where only overdetermined positions will be logged, then at least five satellites are required to compute a position.

Transfer aborted

This message is displayed on the *File transfer* status form if you cancel the transfer of a file in Pathfinder Office.

Unable to append to a file over one week old

This error message is displayed if you attempt to capture data to a file which was created over one week ago. You must create a new data file (possibly using the same data dictionary as is associated with the older data file) and use it to capture data.

Unable to connect

Asset Surveyor was unable to connect to the indicated external sensor. Another sensor or a GPS receiver may already be connected on that serial port.

Unable to open index file

An internal file on the TDC2 has been erased or become corrupted. Contact your Trimble Assistance Center for assistance.

Unable to open serial port. This port may already be in use.

This message indicates that Asset Surveyor was unable to connect to the chosen sensor or GPS receiver, probably because that serial port is already in use by another external sensor or GPS receiver. Reconfigure the external sensor to use another TDC2 serial port.

Unable to quickmark

Asset Surveyor displays this message on the GPS status line if you press the **QUICK** softkey at a time when there is no current GPS position available (e.g. due to a high PDOP situation). In these conditions, Asset Surveyor cannot record a quickmark.

You should return to the location of the feature in question and re-record it, either as a normal or nested point feature, or (if you have altered your masks or you believe that the GPS satellite visibility has improved) by attempting to quickmark the feature again.

Use GPS key to reconnect GPS

This message appears whenever you disconnect the GPS receiver as a reminder that you can press **GPS** to cause Asset Surveyor to communicate with the GPS receiver again.

User code disabled: Please contact your service provider

This message will be displayed if your licence to use the satellite corrections from Racal LandStar or Fugro OmniSTAR has expired. This will mean that you are unable to receive real-time corrections from these services. You should contact your local service provider to re-acquire these corrections.

Validating

Asset Surveyor is busy validating the attribute values that you have entered prior to saving the feature into the data file. While most validation occurs while you are entering attributes, some checks are only possible once all the data has been entered. These checks are performed at this stage.

This message also appears when you have altered fields in a configuration form and then pressed **OK** to save the changes.

Value invalid for DD.MMSSss format

You have entered an invalid value into an angle or latitude/longitude field, and the current configured *Angles* setting is DD.MMSSss. This format for angles requires you to specify each of the components of the angle in sequence, remembering to precede values less than 10 with a 0. For example, the value 23°6'8.56" would be entered as 23.060856.

The 'DD.MMSSss' format for entry of angles should not be confused with the entry of angles as decimal degrees ('DD.ddd') or as degrees and decimal minutes ('DD MM.mmm').

Value with no associated unit

You have entered too many values, separated by spaces, into a numeric field with associated units. For example, entering '1 2 3 4' into a field that expects values as degrees, minutes and seconds will produce this error message; Asset Surveyor does not know what units to assign to the fourth value.

Waiting for input from the PC...

This message appears when you are upgrading the Asset Surveyor software in the TDC2. The TDC2 waits until the UPGRADE program, running on the PC, starts stage 1 of the upgrade procedure. See Chapter 3 for details of upgrading the TDC2.

Wait until a range has been recorded before releasing the laser trigger

When using a ProSurvey 1000 laser rangefinder, it is necessary to press and hold the trigger for 1-2 seconds to allow the laser to take a measurement to the target. If you press and release the trigger too quickly, Asset Surveyor will warn you with the above message.

Waypoint received

This message is displayed on the *File transfer* status form when a waypoint is transferred from Pathfinder Office to the TDC2.

Waypoint sent

This message is displayed on the *File transfer* status form when a waypoint is transferred from the TDC2 to Pathfinder Office.

You cannot append to a base file when RTCM output is active

This error message appears if you try to append to a base file when RTCM output is configured to On.

You cannot review multiple files concurrently

This error message appears when you press while already reviewing a file. You can only review one data file at once. Exit data review of the first file before pressing to review another data file.

You must restart base file for the RTCM changes to have effect

This error message will appear when you configure RTCM output to On while a base station file is already open.

C Asset Surveyor Limits

While the Asset Surveyor system is extremely flexible, it does operate within certain limits, imposed either by the computer on which it runs, or by its internal architecture. Most of these limits will not normally restrict your operation of the system. Even if your application stretches Asset Surveyor's capabilities to the limit, you can generally configure your Asset Surveyor system or your Data Dictionaries in such a way that you can avoid any operational restrictions.

Maximum Features per Data Dictionary

Each data dictionary can define up to 254 types of geographic feature.

Maximum Attributes per Feature

Each feature can have up to 254 attributes.

Maximum Values per Menu Attribute

Each menu attribute can have up to 254 values, not counting the optional null value.

Numeric Attribute Values

The magnitude of numbers which can be entered as attribute values can not exceed $\pm 999,999,999,999,999$. All numeric attributes actually impose a range of permitted values which may be more restrictive than this maximum range.

Character String Attribute Values

The maximum length of a character string attribute value is 100 characters. All character string attributes actually impose a limit on the length of that attribute value which may be shorter than the maximum length.

Length of Notes

A note entered in the Asset Surveyor software can be at most 80 characters long.

Data Storage Space

The TDC2s distributed by Trimble have 3 MB available for data storage. A small amount of this storage space may be used by Asset Surveyor to store waypoints, data dictionaries, language files and coordinate system files, but typically 95% of the TDC2's available memory is available for storage of data files.



Note – When the TDC2's memory becomes completely full, Asset Surveyor will display a *File error* and wait for you to press a key. It will then reboot the TDC2 to ensure that the Asset Surveyor software restarts cleanly. You should transfer your data file(s) to your office PC and delete them from your TDC2 before using Asset Surveyor for further data collection.

Maximum Data Files

Apart from the restriction imposed by the finite data storage capacity of the TDC2, Asset Surveyor permits a maximum of 120 data files at any one time.

Maximum Waypoints

The Asset Surveyor software permits a theoretical maximum of 32767 waypoints to be defined at any time. In practice, Asset Surveyor's *Waypoint manager* will begin to operate more slowly as you add more waypoints to its list. Operation of the *Waypoint manager* with up to 1000 waypoints is typically quite acceptable. You should generally try to delete unused waypoints to keep the list to a manageable size.

Maximum ESP External Sensors

The TDC2 has two serial ports available for the connection of an optional barcode wand, external sensors or a laser rangefinder.

Maximum Coordinate Systems

There can be at most 32767 coordinate systems defined, including the two built-in coordinate systems (*Latitude/Longitude* and *UTM*).

Maximum Zones per Coordinate System

There can be at most 32767 zones for each coordinate system.

Maximum Datums

There can be at most 32767 datums defined.

The total number of coordinate systems, zones and datums cannot exceed 65535.

Maximum Language Files

The theoretical maximum number of languages which Asset Surveyor could support at one time is 254.

Maximum Age for a Data File

You can capture data to a file for up to seven days after the file was created. After seven days, Asset Surveyor will not allow you to capture further data to the file (although you are allowed to review and edit it). This restriction is due to a technical limitation related to the way in which GPS times are stored. In order to maintain full accuracy of storage, it is necessary to limit the time-span of a data file to seven days. If Asset Surveyor displays the following message:

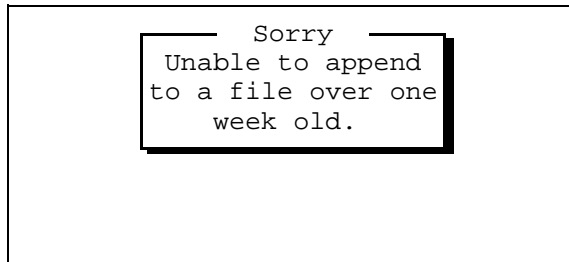

you should create a new data file and capture data to that.

Index

Numerics

- 12-hour clock 5-87
- 24-hour clock 5-87
- 2D altitude 5-14, 6-7, 6-30
- 2D mode 5-14, 6-30
- 2D position 5-14
- 3D mode 5-14, 5-20
- 3D position 5-14

A

- Abandon changes 4-16
- Accuracy
 - Auto 2D/3D mode 5-15
 - geometry 5-19
 - low satellites 5-17
 - weak signals 5-18
- Activating
 - external sensors 7-65
 - laser rangefinders 7-70
- Almanac 6-8, 7-74
 - date 7-74
- Alphanumeric fields 4-21
- Altitude 5-39
 - reference 5-80
- AM softkey 4-30

- Angle format 5-78
- Angle units 5-77
- Antenna
 - height 5-40, 7-13
 - options 5-39, 5-56, 7-79
 - type 5-41
- Antenna softkey 5-39, 5-56
- Area features 7-18, 8-10
- ASCOORD.DAT file 7-51
- Attributes 5-90, 5-104
 - default 7-24
 - entering values 7-19
 - quickmark 5-91
- Audible click 5-22, 5-108
- Auto 5-34
- Auto 2D/3D 5-14
- Auto power mode 5-34
- Auto range mode 5-34
- Auto shutoff 5-113
- Averaged position 8-9

B

- Backlight 2-11, 5-112
- Barcode wand 2-13
- Barcodes 4-31
- Base station 7-76

- creating a file 7-77
- exiting 7-83
- options 5-51
- reference position 7-80
- start 7-82
- status form 7-82

Batteries 5-114

- GPS receiver 6-19

Beacon

- control 5-33
- status 6-24

Beacon softkey 5-32

Bearing 5-81, 7-45

Beep volume 5-113

Bulletin Board System (BBS) xi

C

Carrier mode 7-3, 7-13

Carrier Phase 5-10

Carrier phase

- measurements 7-22
- options 5-33

Carrier time 6-18

Centroid 8-10

Clear softkey 7-60

Clock 5-88

Code softkey 5-102

Comms softkey 5-109

Communications

- external sensors 5-109
- GPS receiver 6-2, 6-32
- PC 7-50
- RTCM 5-27

Compass 5-81, 7-44

Configuration menu 4-4, 5-1

Configuring 7-76

- base station 7-82
- coordinate systems 5-62
- date 5-87
- display 5-74
- external sensors 5-98, 7-67
- GPS 5-2
- language 5-85
 - keypad 5-86
- laser rangefinders 5-111
- quickmark options 5-90, 7-27
- time 5-87
- units 5-74

Confirm 5-42, 5-91

Constant offsets 5-92

Contrast level 2-11, 5-112

Coordinate order 5-79

Coordinate systems 5-62

- over and up 5-66, 5-72, 6-14
- selecting 5-66
- transferring 7-51

Create softkey

- for waypoints 7-56

Creating

- a file 7-77
- base station files 7-77
- rover files 7-3
- waypoints 7-56

Cross-track error 7-44

CTS flow control 5-60

Current 4-12

D

Data

- capacity 2-4
- capture 7-2, 7-41

Data dictionaries 7-11

- deleting 7-12
- generic 7-3
- selecting 7-3, 7-11

Data files

- age of 7-6
- base station 7-77
- creating 7-3
- deleting 7-9
- editing 8-3
- end time 7-8
- initial letter 4-32
- names 4-32
- reopening 7-6
- reviewing 8-3
- start time 7-8
- statistics 7-7
- transfer 7-50

Date 5-87, 5-89

- fields 4-28
- format 5-89

Datum transformation 5-64

Datums 5-62

Deactivating

- external sensors 7-66

Del softkey

- for data dictionaries 7-12
- for languages 5-85
- for waypoints 7-60

Deleting 7-60

- all waypoints 7-60

data dictionaries 7-12

data files 7-9

features 8-17

languages 5-85

single waypoints 7-60

Deleting and undeleting 8-17

DGPS satellite component 5-35

Dilution of Precision 5-19

Disconnect 6-32

Distance

to go 7-44

units 4-23, 5-76

DOP 5-19, 5-23

Dynamics code 5-24

E

Edit softkey

for waypoints 7-58

Editing 7-58

data files 8-3

fields 4-17

waypoints 7-58

Elevation mask 5-17, 5-55

Ellipses 4-12

Ellipsoid 5-62

End softkey 7-47

Entering

a note 8-1

attribute values 7-19

offsets 7-34

Error messages B-1

Escape character 5-101

ESP

data 7-17

Index

- limitations 5-97
- Exit
 - a field 4-19
 - a form 4-16
 - base station 7-83
 - data capture 7-41
 - data review 8-5
- Exiting 7-41
- Exponential notation 4-22
- Ext softkey 7-37, 7-38, 7-69
- External sensors 5-96, 7-17, 7-37, 7-64, 7-69
 - activation 5-99, 7-65
 - automatic 5-99, 7-37
 - manual 5-99, 7-37
 - attribute 5-104
 - audible click 5-108
 - channel 5-100
 - Comms softkey 5-109
 - configuring 5-98, 7-67
 - data received 5-106
 - data request 5-102, 7-67
 - deactivation 7-37, 7-66
 - name 5-100
 - reading 7-67
 - status 7-68
 - status line 5-108
 - testing 7-64

F

- Factory defaults 7-63
- Features
 - area 7-18
 - deleting 8-17

- into waypoints 8-11
- line 7-18
- nested 7-30
- point 7-17
- positions 8-9
- quickmark options 7-26
- repeating 7-24, 8-5
- saving 7-20
- segmented 7-32
- starting 7-16
- un-deleting 8-18

Feet 5-75

Fields 4-12

- alphanumeric 4-21
- captions 4-12
- current 4-12
- date 4-28
- editing 4-17
- menus 4-26
- moving between 4-14
- numeric 4-22
- prompts 4-12
- time 4-29
- values 4-12

File names 4-32, 7-3, 7-77

File transfer 7-50

First letter search 4-9, 4-27

Forced overdetermined mode 5-16

Formatting

- angles 5-78
- coordinates 5-79
- dates 5-89
- times 5-87

Forms 4-12

Free space 5-113

Frequency 5-35

Func key 2-10

G

Geoid 5-63

GPS

configuration 5-2

operations 6-11

menu 4-3

receivers 1-5

Greenwich mean time 4-32

H

HAE 5-80

HDOP 6-17

Heading

direction of travel 7-45

Height above ellipsoid 5-80

Here softkey 7-57, 7-58, 7-81

I

Info softkey 7-84

Information for new users 7-84

Information messages B-1

Initial letter 4-32

Initial position 5-26, 6-10

Interpolated position 8-9

K

Key click 5-113

Keypad 2-9, 5-86

L

Language 1-4, 5-85, 7-52

Laser rangefinders 5-96, 7-37, 7-64,
7-69

activation

automatic 5-111, 7-38

manual 7-38, 7-70

deactivation 7-38

magnetic declination 5-83

recording offsets 7-38, 7-71

status 7-71

testing 7-69

type 5-111

updating offsets 8-13

Latitude / Longitude 5-67

LCD Contrast 5-112

Line features 7-18, 8-10

LNG file 7-52

Local time 4-32

Log PP data 5-31

Logging

data 7-13

DOP data 5-23, 5-54

intervals 5-5

line / area 5-5

not in feature 5-5

point feature 5-5

synchronized 5-7, 5-53

velocity 5-6

notes 7-15

pause 7-22

PP data 5-31

resume 7-22

M

- Magnetic
 - declination 5-82
 - north 5-81
- Main menu 4-2, 7-1
- Manual 2D 5-15
- Manual 3D 5-14
- Map projection 5-64
- Masks
 - elevation 5-17
 - PDOP 5-19
 - SNR 5-18
- Maximum message length 5-97, 5-107
- Mean sea level 5-80
- Measurements 5-53
- Measuring
 - between waypoints 7-61
- Memory available 2-4, 5-113, 7-4, 7-8, 7-77
- Menu fields 4-26
- Menus 4-8
- Messages 4-6
 - error B-1
 - information B-1
 - on GPS status line 6-5
 - warning B-1
- Minimum positions 5-8
- Minimum time 7-21
- Mode 6-16
- Moving
 - between fields 4-14
- MSL 5-80

N

- NAD-27 5-69
 - NAD-83 5-69
 - Nav1 softkey 7-43
 - Nav2 softkey 7-43
 - Nav3 softkey 7-44
 - Navigation 6-28, 7-42
 - from waypoint to waypoint 7-49
 - to a waypoint from your current position 7-47
 - waypoints 7-47
 - Nest softkey 7-30
 - Nested features 7-30
 - NMEA 5-107
 - output 5-47
 - None softkey 5-7
 - North reference 5-81
 - Note key 8-1
 - Now softkey 4-30
 - Null
 - string 5-84
 - value 4-13
 - Numeric fields 4-22
- ## O
- Office support module (OSM) 3-2
 - Offset softkey 7-39
 - Offsets 5-96, 8-12
 - constant 5-92
 - entering 7-34
 - reviewing 8-12
 - updating 8-13
 - Operations 6-11
 - Order of coordinates 5-79

Other 5-70
Outputs
 NMEA 5-47
 options 5-47
 PPS 5-50
 TSIP 5-47
Over and up 5-66, 5-72, 6-14
Overdetermined 3D 5-16
Overdetermined positions 5-14, 5-16
Overwrite 4-18

P

P(Y) options 5-43, 6-4
Page down key 4-8, 4-9
Page up key 4-8
Pathfinder Office software 1-3
Pattern 8-6
Pause and resume logging 7-22
Pause softkey 7-22
PDOP 5-19, 6-3, 6-17
 mask 5-19, 5-55
 switch 5-19, 5-55
PDOP, HDOP, VDOP and TDOP 6-17
PM softkey 4-30
Point features 7-17, 8-9
Position 5-54, 6-13, 8-9
Position dilution of precision 5-19, 6-3,
 6-17
Position mode 5-14, 5-54, 6-16
 Auto 2D/3D 5-14, 5-20
 Manual 2D 5-15
 Manual 3D 5-14
 Overdetermined 3D 5-16
Power 6-19

sources 2-7

PPS 5-43, 6-4
Prefix 5-97, 5-107
PRN 6-21
Projection 5-62

Q

Quick softkey 7-27
Quickmarks 5-90, 7-26

R

Read softkey 7-67
Reading
 from an external sensor 7-67
Real-time differential correction 5-27
Reboot 2-3
Receiver
 info 6-19
 navigation firmware version 6-19
 outputs 5-47
 signal processor firmware
 version 6-19
 status 6-15
Receiving RTCM 6-18
Reference position
 base station 7-80
 over and up 5-72
Reopening
 rover files 7-6
Repeating
 features 7-24, 8-5
Reset 2-3
 GPS receiver 7-72

Resume logging 7-22
Resume softkey 7-22
Reviewing and editing data 8-3
Reviewing data files 8-3
Rover files
 creating 7-3
 reopening 7-6
Rover options 5-3
RS232 5-96, 5-97, 5-109
RTCM
 input 6-18
 input options 5-27
 message interval 5-59
 messages 5-59
 output 5-57
 station 5-30, 5-59
 version 5-29
RTCM softkey 5-52

S

Satellite
 bearing 6-22
 elevation 6-22
 information 6-21, 6-24
 vehicles 6-3, 6-7
Satellite DGPS 5-36
Saving features 7-20
Scientific notation 4-22
Search softkey 8-6
Searching 8-6
Sections 4-15
Seg softkey 7-32
Segmented line features 7-32
Selecting 5-66

 coordinate systems 5-66
 current field 4-14
 data dictionaries 7-3, 7-11
 menu entries 4-8
 values for menu fields 4-27
 waypoints 7-47
Selective availability 6-22
Sensor 1/2 5-98, 5-111
Sensors 5-99
Separator 4-12
Setup softkey
 for base station, GPS 7-82
 for quickmark options 7-27
 for rover, GPS 6-12
Signal strength 6-21
SNR 6-21
SNR mask 5-18, 5-55
Softkeys 4-5
Software and Firmware Version
 Numbers 4-35
SPS 5-43
SSF 5-96
Start softkey 7-47
Starting features 7-16
Starting the Asset Surveyor
 Software 4-1
Starting to Log Data 7-13
Startup 5-26, 6-8
State Plane 5-71
Statistics 7-7
Status
 base station 7-82
 external sensor 7-68
 form 7-82
 laser rangefinder 7-71
 line 6-3

- for external sensors 5-108
- GPS 6-3
- Status softkey
 - for external sensors 7-68
 - for laser rangefinders 7-70, 7-71
- Stopping the Asset Surveyor
 - Software 4-1
- Suffix 5-107
- SV *see* Satellite
- Symb softkey 4-21, 5-102
- Synchronized intervals 5-7, 5-53

T

- TDC1 1-2
- TDOP 6-17
- Time 5-87, 5-88
 - fields 4-29
 - format 5-87
 - GMT 4-32
 - local 4-32
 - to go 7-45
 - UTC 4-32
- Timeout 5-97, 5-107
- Today softkey 4-29
- Transfer to/from PC 7-50
- Transformation 5-64
- Translations of Asset Surveyor 5-85
- Troubleshooting A-1
- True north 5-81
- TSIP output 5-47
- TTG 7-45
- Turning the TDC2 on and off 2-2
- Type 1 5-59
- Type 9 5-59

U

- U.S. Coast Guard 5-29
- Unattended Real-Time Base
 - Station 5-52, 5-57, 7-83
- Un-deleting
 - features 8-18
 - notes 8-18
- Unhealthy satellites 6-22
- UNINTERPRETED_SENSOR_DATA
 - 5-96, 5-100, 5-104, 5-106, 5-107
- Units 4-22, 4-23, 5-74, 5-75
- Units and display 5-74
- Units softkey 4-25
- Unknown softkey 7-80
- Upgrade software 3-2, 7-75
- US Survey feet 5-75
- USCG 5-29
- User Access 6-20
- User range accuracy (URA) 6-22
- UTC 4-32
- Utilities menu 7-53
- UTM 5-68

V

- Value 4-12
- VDOP 6-17
- Velocity 5-6
 - over ground 7-45
 - units 5-77
- Version numbers 4-35
- View key 8-3

W

Warning messages B-1

Waypoints 6-29, 7-47, 7-54

- creating 7-56

- deleting 7-60

- editing 7-58

- from features 8-11

- measuring between 7-61

- navigating between 7-47

- reference positions 7-81

Waypt softkey 6-14, 7-81, 8-11

WGS-84 5-62

Windows 4-13

Z

Zones 5-65

- selecting 5-71

