

PAIRGAIN TECHNOLOGIES PG-FLEX™ COT LINE UNIT

MODEL FLL-722 List 1

PairGain # 150-1322-01
CLEI Code: VACHDE0CAA

CONTENTS	PAGE
A. PRODUCT OVERVIEW	
1. DESCRIPTION AND FEATURES	2
2. APPLICATIONS	2
3. SPECIFICATIONS	3
4. CERTIFICATION	4
5. WARRANTY	4
B. FUNCTIONAL DESCRIPTION	
6. OPERATIONAL CAPABILITIES	4
7. FRONT PANEL	5
8. TERMINAL MANAGEMENT	6
C. INSTALLATION AND TEST	
9. UNPACKING	8
10. TURN-UP AND TESTING	8
11. TROUBLESHOOTING	8

CAUTION

This product incorporates static sensitive components. Proper electrostatic discharge procedures must be followed.

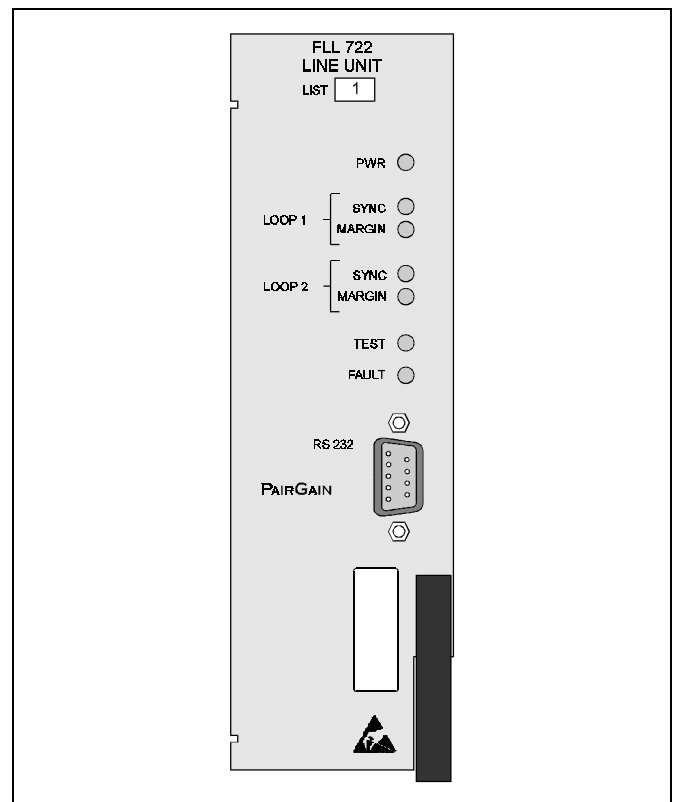

Figure 1. FLL-722 COT Line Unit, List 1, Front Panel. The PairGain FLL-722 is the Central Office end of a PG-Flex subscriber carrier system.

A. PRODUCT OVERVIEW

1. DESCRIPTION AND FEATURES

1.01 The PG-Flex FLL-722 Central Office Terminal (COT) Line Unit, List 1 is the Central Office end of a subscriber carrier system that uses two pairs of unconditioned copper wire as a carrier for up to 12 independent subscriber channels between a COT and a Remote Terminal (RT). The FLL-722 COT Line Unit uses PairGain's High-bit-rate Digital Subscriber Line (HDSL) technology to provide the equivalent of 1.544 Mbps digital transmission rates, plus signaling over two copper pairs without the need for repeaters, loop conditioning, or pair selection.

1.02 The FLL-722 COT Line Unit resides in a PairGain COT Shelf; one FLL-722 COT Line Unit is required for each system.

1.03 Revision History of this practice:
Revision 01 - February 12, 1996
a) Initial release.

1.04 FLL-722 COT Line Unit, features:

- Distributed Subscriber Carrier System Architecture
- Proven PairGain HDSL (2B1Q) technology operates on unconditioned copper pairs
 - Bridge Taps
 - No Pair Selection
 - No Repeaters

2. APPLICATIONS

2.01 PG-Flex is a small capacity universal subscriber carrier system supporting up to 24 subscriber channels, including POTS and ISDN services. The system is based on HDSL transmission technology and the remote power is powered from the central office. Using two 24 gauge unconditioned copper pairs, the remote terminal may be located up to 12.3 kft from the central office terminal. Standard 19- or 23-inch shelves contain multiple systems; circuit cards may be hot-swapped without affecting other systems installed in the shelf. POTS channel units use 64-kbps μ -Law PCM encoding to allow Group 3 facsimile or high-speed modem operation on all channels.

2.02 System Flex Configuration. A PG-Flex system, shown in Figure 2 consists of:

- Central Office Terminal (COT). Two complete systems may be installed in a 19-inch COT Shelf and four complete systems may be installed in a 23-inch COT Shelf. Each system requires one COT Line Unit and up to three (23-inch

shelf) or six (19-inch shelf) Channel Units. A common Alarm Unit or Pair Gain Test Controller Interface Unit in each shelf provides an interface for maintenance alarm relays and metallic access to the remote subscriber lines.

- Remote Terminal (RT). The RT Enclosure provides a weatherproof housing for the PG-Flex remote electronics and subscriber terminations. The enclosure accepts one common RT Line Unit and up to four Channel Units. The Remote Terminal communicates with, and is line-powered from, the COT over two pairs of 19- to 26-gauge twisted-pair telephone wire. Each pair carries both power and HDSL signaling.

2.03 HDSL Transmission. PG-Flex utilizes HDSL transmission technology between the COT and RT and provides up to 24 DS0s, plus signaling, over two copper pairs without the need for repeaters, loop conditioning, or pair selection. Adaptive equalization, scrambling, and a four-level 2B1Q line coding scheme increase range and minimize crosstalk.

2.04 The line interface is a two-pair, 784-kbps full-duplex 2B1Q transmission format. The dual HDSL lines provide 24 64-kbps channels with signaling, and an embedded operations channel for management control. The signal characteristics on the carrier pairs comply with TR-NWT-001210, Generic Requirements for High-bit-rate Digital Subscriber Line (HDSL) Systems.

2.05 For the system configuration depicted in Figure 2, the maximum distance between the COT and the RT is 12.3 kft (3.8 km), assuming the HDSL lines are 24 gauge. Table 1 shows the maximum distance between the COT and RT for various gauge wire. Due to the nature of HDSL transmission technology, the HDSL lines do not require any special conditioning and may include unterminated bridge taps, but cannot include load coils.

2.06 Subscriber Drop Testing. For subscriber drop testing from the central office, PG-Flex is able to select and connect any subscriber drop to a metallic test pair at the RT. PG-Flex extends this connection back to the COT where technicians can switch it onto a test access bus, or to the corresponding subscriber line on the COT channel card.

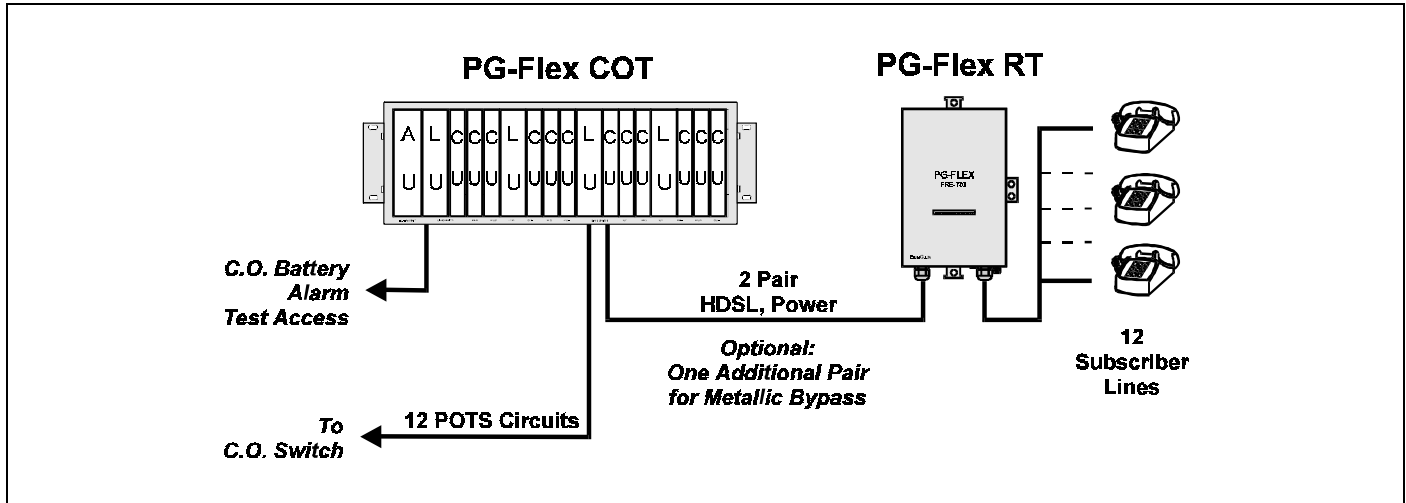

Figure 2. Typical PG-Flex Configuration.

TABLE 1. PG-FLEX DISTANCES

Wire Gauge	Loop Length	
	12/24 Channel System	Resistance
26 AWG (0.4 mm)	9.0 kft (2.8 km)	750Ω
24 AWG (0.5 mm)	12.3 kft (3.8 km)	638Ω
22 AWG (0.6 mm)	16.1 kft (5.0 km)	521Ω
19 AWG (0.9 mm)	22.8 kft (7.0 km)	367Ω

2.07 Test access is achieved by placing +116 V on the subscriber's COT tip lead for 1.5 seconds, then removing the +116 V. Depending on the configuration of the PG-Flex system, the selected subscriber drop (assuming a working metallic bypass pair) will be connected to either the corresponding COT subscriber line or to the test access bus.

2.08 The test connection will be dropped when -116V is applied to the subscriber's COT tip for 1.5 seconds, then removing the -116 V.

2.09 Test access may also be activated through the RS-232 Maintenance Port located on the front of the COT and RT Line Units, using an ASCII terminal.

3. SPECIFICATIONS

COT Power Supply Input Voltage

-42 to -56 V dc

COT Power Supply Input Power

145 Watts (maximum)

COT Power Supply Input Protection

Fuse (2A GMT)

COT Power Supply Output Voltage

± 130 V dc (maximum)

COT Power Supply Output Power

100 Watts (maximum)

Operating Temperature & Humidity (non-condensing)

-40° to +65° Celsius, 5% to 95%

Operating Elevation

200 feet (60 m) below sea level to 13,000 feet (4,000 m) above sea level.

Dimensions

Height: 6.75" (17.2 cm)

Width: 2.00" (5.1 cm)

Depth: 10.50" (26.7 cm)

Weight

2.0 lbs. (0.9 kg)

4. CERTIFICATION

4.01 FCC Compliance. The FLL-722 COT Line Unit complies with the limits for Class A digital devices pursuant to Part 15 of the FCC rules. These limits are designed to provide reasonable protection against harmful interference when the equipment is operated in a commercial environment. This equipment generates, uses and can radiate radio frequency energy and, if not installed and used in accordance with the instruction manual, may cause harmful interference to radio communications. Operation of this equipment in a residential area is likely to cause harmful interference in which case the user will be required to correct the interference at his own expense.

4.02 Refer to the installation section of the appropriate practice for the unit being installed to get information on:

- Cabling
- Proper connections
- Grounding
- Line power

4.03 All wiring external to the product(s) should follow the provisions of the current edition of the National Electrical Code.

5. WARRANTY

5.01 PairGain Technologies warrants this product to be free of defects and to be fully functional for a period of 36 months from the date of original shipment, given proper customer installation and regular maintenance. PairGain will repair or replace any unit without cost during this period if the unit is found to be defective for any reason other than abuse or improper use or installation.

5.02 This module should not be field repaired. If it fails, replace it with another unit and return the faulty unit to PairGain for repair. Any modifications of the unit by anyone other than an authorized PairGain representative will void the warranty.

5.03 If a unit needs repair, call PairGain for a Return Material Authorization (RMA) number and return the defective unit, freight prepaid, along with a brief description of the problem, to:

PairGain Technologies, Inc.
14402 Franklin Avenue
Tustin, CA 92680
ATTN: Repair and Return Dept.
(714) 832-9922
(800) 638-0031

5.04 PairGain will continue to repair faulty modules beyond the warranty program at a nominal charge. Contact your PairGain sales representative for details and pricing.

B. FUNCTIONAL DESCRIPTION

6. OPERATIONAL CAPABILITIES

6.01 The FLL-722 COT Line Unit provides the following functions for each 12-channel system in a single COT shelf:

- System Power Supply
- HDSL Line Transceivers and Simplex RT Power
- Front-Panel Status Indicators
- RS-232 Maintenance Interface (DCE)
- Switched Access to the Metallic Bypass Pair

6.02 A block diagram of the FLL-722 is shown in Figure 3. The power supply isolates and converts CO battery into the voltages used by PG-Flex, including ± 130 V dc, which is simplexed onto the HDSL lines. During power-up, the system automatically checks for HDSL line conditions which may indicate a problem with the line or which may present a potentially hazardous condition for the technician; under these conditions, PG-Flex will not complete the power-up process and indicate a line problem on the front panel LED indicators.

6.03 The RS-232 Maintenance Port located on the front of the Line Unit (see Figure 1) enables the technician to configure and test the PG-Flex system using an ASCII terminal (see Section 8). A terminal is not required for normal installation and operation of PG-Flex, but may facilitate troubleshooting procedures on the HDSL line.

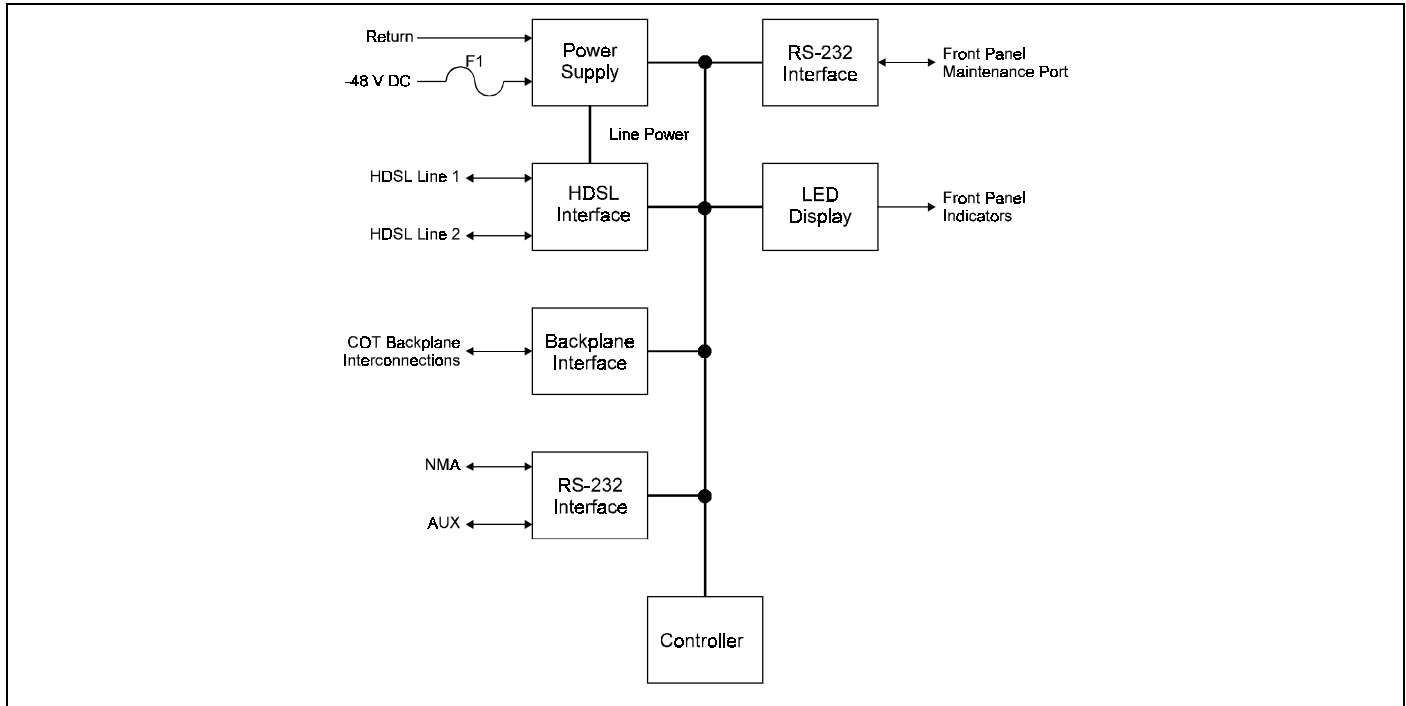

Figure 3. FLL-722 COT Line Unit Block Diagram.

7. FRONT PANEL

7.01 The front panel of the FLL-722 COT Line Unit contains the following indicators and connector (see Figure 1):

- **POWER** LED Indicator
 - Green*—power is applied and the line feed is normal.
 - Off*—the system is not receiving power. The COT Line Unit fuse may have blown.
- **LOOP 1 SYNC** LED Indicator
 - Green*—HDSL line 1 is in sync between the COT and RT.
 - Flashing Green*—HDSL line 1 is attempting to synchronize with the remote unit.
 - Off*—HDSL line 1 does not detect an active remote unit.
- **LOOP 1 MARGIN** LED Indicator
 - Yellow*—HDSL line 1 margin is below a preset level.
 - Off*—HDSL line 1 margin is above the preset level.
- **LOOP 2 SYNC** LED Indicator
 - Green*—HDSL line 2 is in sync between the COT and RT.
 - Flashing Green*—HDSL line 2 is attempting to synchronize with the remote unit.
 - Off*—HDSL line 2 does not detect an active remote unit.
- **LOOP 2 MARGIN** LED Indicator
 - Yellow*—HDSL line 2 margin is below a preset level.
 - Off*—HDSL line 2 margin is above the preset level.
- **TEST** LED Indicator
 - Yellow*—a subscriber drop or diagnostic test has been activated on any unit in the system.
 - Off*—there are no tests activated in the system.
- **FAULT** LED Indicator
 - RED*—there is a fault in the system.
 - Off*—no faults are detected in the system.
- **RS232** DB-9F Connector
 - This connector is used by technicians to configure the PG-Flex.

8. TERMINAL MANAGEMENT

8.01 The terminal management function of the PG-Flex enables a technician to manage the entire PG-Flex system through an ASCII terminal (or modem) connected to the maintenance port at either the CO or the RT. The pin-outs for the standard RS-232 (DB-9) maintenance port connector are shown in Figure 4. With the management function, the technician can view system status, set configuration parameters, conduct testing, monitor performance, and obtain an inventory report.

8.02 Craft Maintenance Port. The craft maintenance port to which the management terminal connects is available at both the CO Line Unit and all RT Line Units. The craft port is set up as DCE with 8 data bits, 1 stop bit, and no parity. Striking the SPACE bar rapidly several times invokes the autobaud feature, which covers a 1,200 to 9,600 bps range. It requires DTR active from the terminal to prevent automatic log off.

8.03 Menus and Displays. Figure 5 (on next page) shows the menu structure of the terminal management system. Following are brief descriptions of each menu and display screen:

- **Log On Screen.** The Line Unit displays this screen when it detects the user's input from the maintenance port while in an idle state. Password input is echoed with "*" characters. If the technician does not enter the correct password after 5 tries, the Line Unit locks out the log on procedure for 10 minutes.
- **Main Menu.** After receiving the correct password, the terminal displays the Main Menu from which the technician can choose any of the following options:
 - Status
 - Setup
 - Test
 - Inventory
- **Status.** By selecting the Status option (A) from the Main Menu, the technician can:
 - Display System Status to show the equipment installed in the system and the current status (in alarm or not) of the equipment. An "*" next to the unit name indicates that the unit is currently in the alarm state.

- Display Channel Status to show the current status of all channels in the system. Each channel has one of the following status conditions:
 - IDLE: The channel is not off-hook or ringing.
 - RING: The channel is ringing.
 - BUSY: The channel is off-hook.
 - OPEN: There is no connection to CO switch.
- Display HDSL Status to show the status of the HDSL segment. The HDSL segment has one of the following status conditions:
 - ACTIVE: The segment is functioning normally.
 - ALARM: The segment is in alarm.
 - NONE: The segment is not equipped.
- Display Performance History to show the 24-hour performance history or the 7-day performance history of the HDSL segment.
- **Setup.** By selecting the Setup option (B) from the Main Menu, the technician can view the current setup and set or change the following configurable items:
 - System Time, Date, and ID
 - System Password
 - Auto Log Out Time
 - Metered Tone Frequency
 - Ring Frequency
 - HDSL 24-Hour ES Threshold
 - HDSL Margin Alarm Threshold
 - Alarm On Threshold
- **Test.** By selecting the Test option (C) from the Main Menu, the technician can:
 - Select a channel for testing. The selected channel is switched out of the DLC and is connected to a metallic bypass wire.

Inventory. By selecting the Inventory option (D) from the Main Menu, the technician can view manufacturing information of all the units in the system. At the CO, the command displays all units in the system; at the RT, only those units in the local cage are displayed.

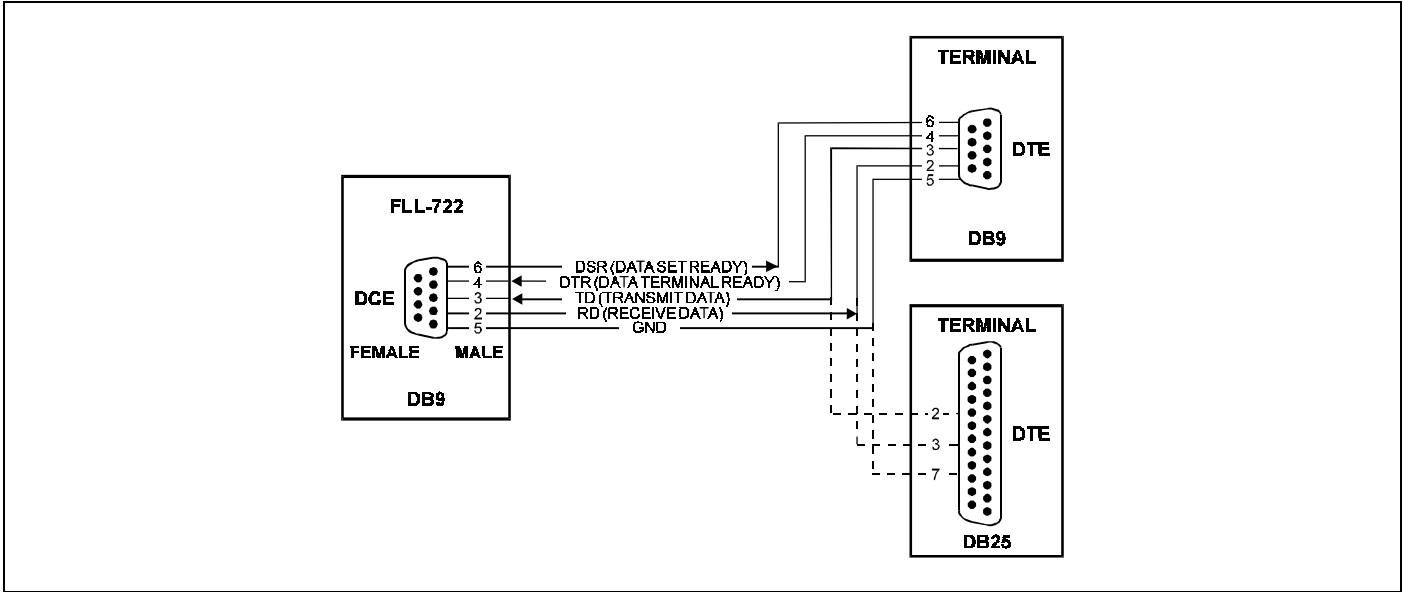

Figure 4. FLL-722 DB-9 Pin Outs. A standard RS-232 (DB-9) connector on the front panel provides access to the menu interface feature via a dumb terminal.

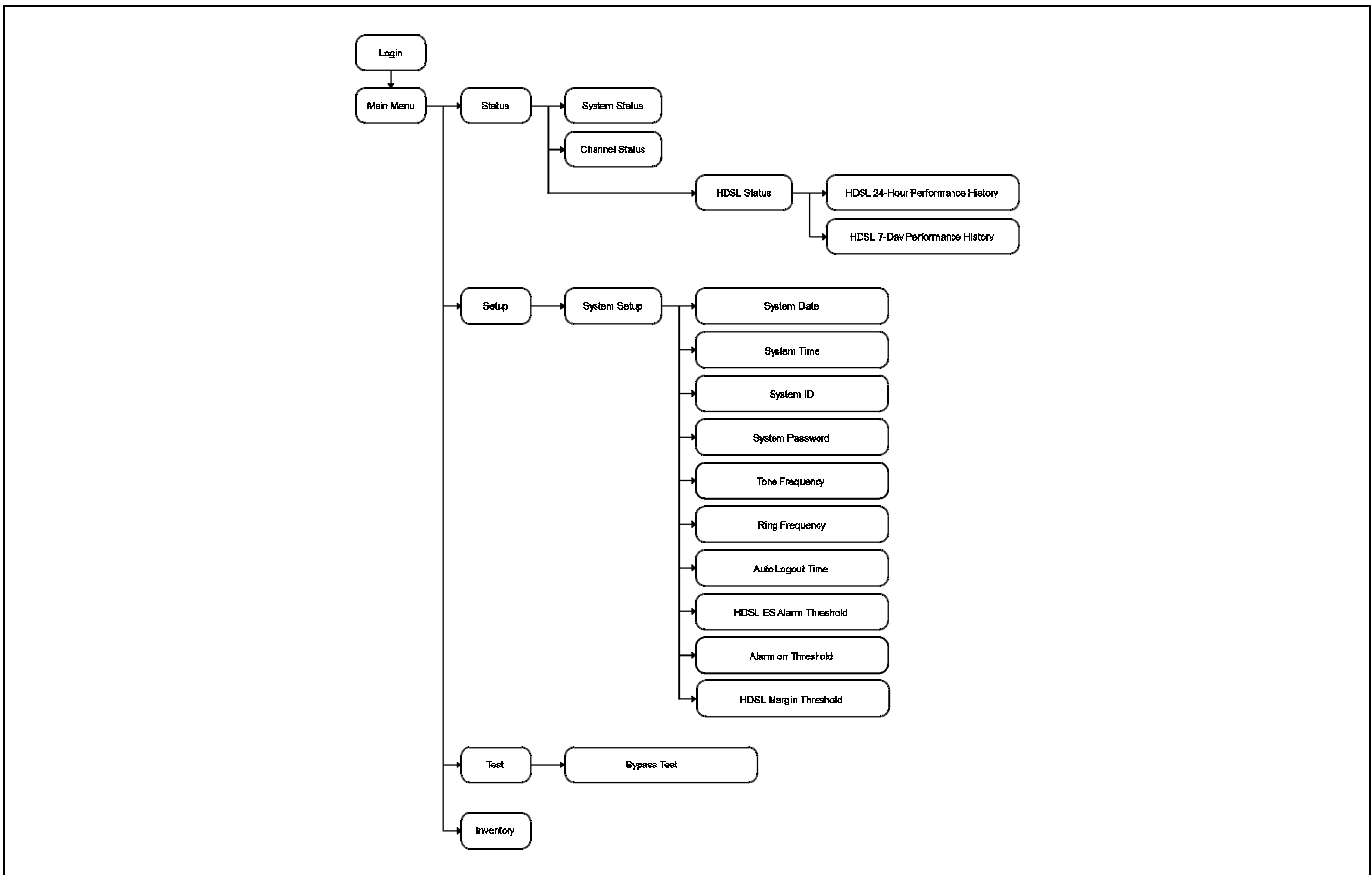

Figure 5. Terminal Menu and Display Structure.

C. INSTALLATION AND TEST

9. UNPACKING

9.01 Upon receipt of the equipment, proceed as follows:

1. Unpack each container and visually inspect it for signs of damage. If the equipment has been damaged in transit, immediately report the extent of damage to the transportation company and to PairGain. Order replacement equipment if necessary.
2. Check the contents versus the packing list to ensure complete and accurate shipment. If the shipment is short or

irregular, contact PairGain as described in Section 5. If you must store the equipment for a prolonged period, store the equipment in its original container.

10. TURN-UP AND TESTING

10.01 Table 2 provides step-by-step turn-up and test procedures for the FLL-722 COT Line Unit.

11. TROUBLESHOOTING

11.01 Table 3 provides troubleshooting procedures based on indications displayed by the front panel indicators of FLL-722 COT Line Unit. Table 4 contains a glossary of PG-Flex terms.

TABLE 2. FLL-722 COT LINE UNIT TURN-UP AND TESTING

CAUTION			
Observe normal electrostatic discharge precautions when handling electronic equipment. Do not hold electronic plug-ins by their edges. Take care not to touch components or circuitry.			
Step	Operation	Action	Observe
1	Install COT Line Unit	a. Insert the FLL-722 COT Line Unit into the COT Shelf.	<ul style="list-style-type: none"> • All LEDs on the COT Line Card turn <i>on</i> for approximately 7 seconds, then scan from top to bottom • The PWR LED and FAULT LED turn <i>on</i>
		b. After about 4 seconds, COT enters power management routine. If line powering fails, COT waits about 1 minute before attempting again.	<ul style="list-style-type: none"> • PWR LED flashes
		c. If line powering succeeds, HDSL communications begin synchronizing.	<ul style="list-style-type: none"> • LOOP 1 SYNC and LOOP 2 SYNC flash
		d. After the system has powered up, established HDSL synchronized communications, and no calls are in progress, observe the COT Line Unit front panel indicators.	POWER <i>on</i> LOOP 1 SYNC <i>on</i> LOOP 1 MARGIN <i>off</i> LOOP 2 SYNC <i>on</i> LOOP 2 MARGIN <i>off</i> TEST <i>off</i> FAULT <i>off</i>
2	Measure Voltages	a. Make the following measurements on the COT Shelf backplane:	<ul style="list-style-type: none"> • -130 Vdc, ±10%, between A_HDSL_T1 and Chassis Ground. • 0 Vdc to +120 Vdc between A_HDSL_T2 and Chassis Ground (Note: Use B_HDSL_T1 and B_HDSL_T2 for System #2).

TABLE 3. FLL-722 COT LINE UNIT TROUBLESHOOTING

Indication	Problem	Action
POWER LED <i>off</i>	1. The COT Shelf is no longer receiving CO battery.	a) Verify that the fuse on the CO fuse panel is good. b) Verify wiring between the COT Shelf and the CO fuse panel, and from the panel to the CO battery.
	2. The COT Line Unit fuse F1 has blown.	Replace the fuse.
LOOP 1 (2) SYNC LED <i>flashing or off</i>	1. The HDSL line is attempting to synchronize with the central office unit or cannot detect the HDSL signal from the central office unit. This is usually an indication that there is a problem with the HDSL circuit between the COT and RT (assuming the FAULT LED is <i>off</i>). 2. COLU and RTLU incompatible. That is, one is a T1 version and the other is an E1 version.	a) Verify the HDSL circuits are terminated properly and with the correct orientation. b) Measure the loop resistance of each HDSL circuit (shorting the pair at the far end). The loop resistance must be less than that shown in Table 1.
LOOP 1 (2) MARGIN LED <i>on</i>	The HDSL line margin level is below a preset level.	See the previous discussion on the SYNC LED <i>flashing or off</i> .
FAULT LED <i>on</i>	Faulty FLL-722 COT Line Unit.	a) Check that none of the HDSL pairs are shorted to ground. b) Check for continuity from COT to RT on all HDSL lines. c) Replace the COT Line Unit, if the RT line unit is confirmed good. Otherwise, replace the RT line unit.

TABLE 4. GLOSSARY OF PG-FLEX TERMS

<i>Term</i>	<i>Definition</i>
MARGINS	Indicates the excess signal to noise ratio, at either the COT or RT, relative to a 10^{-7} Bit Error Rate. <i>mn</i> is the current margin, <i>cr</i> is the minimum margin since last cleared, <i>mx</i> is the maximum value since cleared, and N/A means Not Available. The normal range of a typical margin is from 22 to 6 dB.
PULSE ATTENUATION	Indicates the attenuation of the 2B1Q pulse from the distant end. PG-Flex operates with pulse attenuations in excess of 30 dB. This value is related to the cable pair's 196-kHz loss. The pulse attenuation is a more direct indication of the loop attenuation to the 2B1Q signal than the 196-kHz loss. The normal range of pulse attenuation is from 1 to 32 dB.
PPM	Indicates the relative offset of the crystal oscillator in the RT Line Unit from the COT Line Unit's crystal oscillator. Any value between -64 and +64 is adequate. Values outside this range indicate out of tolerance components or excessive temperature drift of critical components.
HDSL 24 Hour ES (Errored Seconds)	The number of 1-second intervals that contained at least one CRC error. This value is a running total of the last 24 Hours.
HDSL 24 Hour UAS (Unavailable Seconds)	The number of seconds the HDSL loop was out of synchronization.