

PG-FLEX™ 8 CHANNEL COT POTS UNIT

MODEL FLC-704 List 1

PairGain #150-1304-01

CONTENTS	PAGE
A. PRODUCT OVERVIEW	
1. DESCRIPTION AND FEATURES	2
2. APPLICATIONS	2
3. SPECIFICATIONS	3
4. CERTIFICATION	4
5. WARRANTY	4
B. FUNCTIONAL DESCRIPTION	
6. OPERATIONAL CAPABILITIES	4
7. FRONT PANEL	5
C. INSTALLATION AND TEST	
8. UNPACKING	5
9. TURN-UP AND TESTING	5
10. TROUBLESHOOTING	5

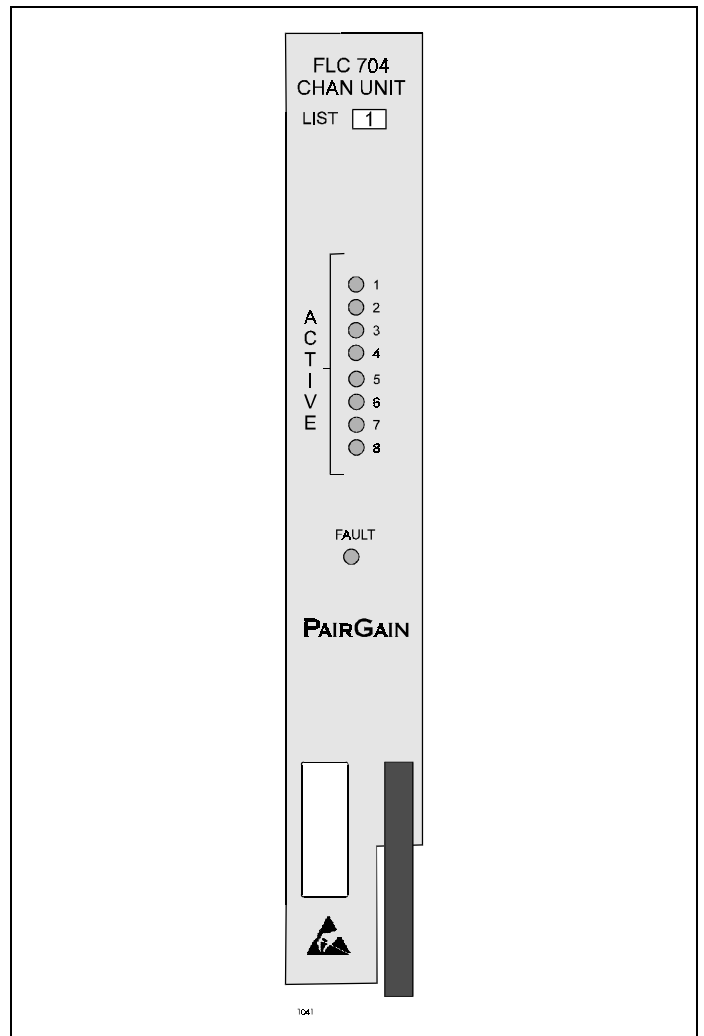

Figure 1. FLC-704 COT Channel Unit, List 1, Front Panel. The PairGain FLC-704 provides eight POTS interfaces between the Central Office and PG-Flex.

CAUTION

This product incorporates static sensitive components. Proper electrostatic discharge procedures must be followed.

A. PRODUCT OVERVIEW

1. DESCRIPTION AND FEATURES

1.01 The PG-Flex FLC-704 Channel Unit provides 8 POTS interfaces between the Central Office and PG-Flex, and uses A-Law PCM encoding. The Model FLC-704 Channel Unit includes green status LEDs for each line indicating idle, ringing, and off-hook conditions, as well as a red LED indicating a fault condition on the Channel Unit. The unit provides metallic test access to the subscriber line connection through an optional metallic bypass pair.

1.02 Revision History of this practice.

Revision 01

May 13, 1996

a) Initial release.

1.03 Features of the PG-Flex FLC-704 COT Channel Unit:

- Eight POTS subscriber interfaces
- 64 kbps A-Law PCM encoding
- Metering Tones (12 kHz, 16 kHz)
- Front panel ACTIVE LEDs indicate idle, ringing, test access, and off-hook for each channel
- Front panel FAULT LED indicator simplifies troubleshooting

2. APPLICATIONS

2.01 PG-Flex is a small capacity universal subscriber carrier system supporting up to 32 subscriber channels, including POTS and ISDN services. The system is based on HDSL transmission technology is remotely powered from the Central Office. Using two 24 gauge (0.5mm) unconditioned copper pairs, the remote terminal may be located up to 10.7 kft (3.3 km) from the Central Office terminal. Standard 19- or 23-inch shelves contain multiple systems; circuit cards may be hot-swapped without affecting other systems installed in the shelf. POTS channel units use 64-kbps A-Law PCM encoding to allow Group 3 facsimile or high-speed modem operation on all channels.

2.02 System Flex Configuration. A PG-Flex system, shown in Figure 2 consists of:

- Central Office Terminal (COT). Two complete systems may be installed in a 19-inch COT Shelf and four complete systems may be installed in a 23-inch COT Shelf. Each system requires one COT Line Unit and up to three (23-inch shelf) or six (19-inch shelf) Channel Units. A common Alarm

Unit or Pair Gain Test Controller Interface Unit in each shelf provides an interface for maintenance alarm relays and metallic access to the remote subscriber lines.

- Remote Terminal (RT). The RT Enclosure provides a weatherproof housing for the PG-Flex remote electronics and subscriber terminations. The enclosure accepts one common RT Line Unit and up to four Channel Units. The Remote Terminal communicates with, and is line-powered from, the COT over two pairs of 19- to 26-gauge (0.9 mm to 0.4 mm) twisted-pair telephone wire. Each pair carries both power and HDSL signaling.

2.03 HDSL Transmission. PG-Flex utilizes HDSL transmission technology between the COT and RT and provides up to 32 DS0s, plus signaling, over two copper pairs without the need for repeaters, loop conditioning, or pair selection. Adaptive equalization, scrambling, and a four-level 2B1Q line coding scheme increase range and minimize crosstalk.

2.04 The line interface is a two-pair, 1110-kbps full-duplex 2B1Q transmission format. The dual HDSL lines provide 32 64-kbps channels with signaling, and an embedded operations channel for management control. The signal characteristics on the carrier pairs comply with TR-NWT-001210, Generic Requirements for High-bit-rate Digital Subscriber Line (HDSL) Systems.

2.05 For the system configuration depicted in Figure 2, the maximum distance between the COT and the RT is 10.7 kft (3.3 km), assuming the HDSL lines are 24 gauge (0.5 mm). Table 1 shows the maximum distance between the COT and RT for various gauge wire. Due to the nature of HDSL transmission technology, the HDSL lines do not require any special conditioning and may include unterminated bridge taps, but cannot include load coils.

2.06 Subscriber Drop Testing. For subscriber drop testing from the Central Office, PG-Flex is able to select and connect any subscriber drop to a metallic test pair at the RT. PG-Flex extends this connection back to the COT where technicians can switch it onto a test access bus, or to the corresponding subscriber line on the COT channel card.

2.07 Test access is achieved by placing +116 V on the subscriber's COT tip lead for 1.5 seconds, then removing the +116 V. Depending on the configuration of the PG-Flex system, the selected subscriber drop (assuming a working metallic bypass

pair) will be connected to either the corresponding COT subscriber line or to the test access bus.

2.08 The test connection will be dropped when -116V is applied to the subscriber's COT tip for 1.5 seconds, then removing the -116 V.

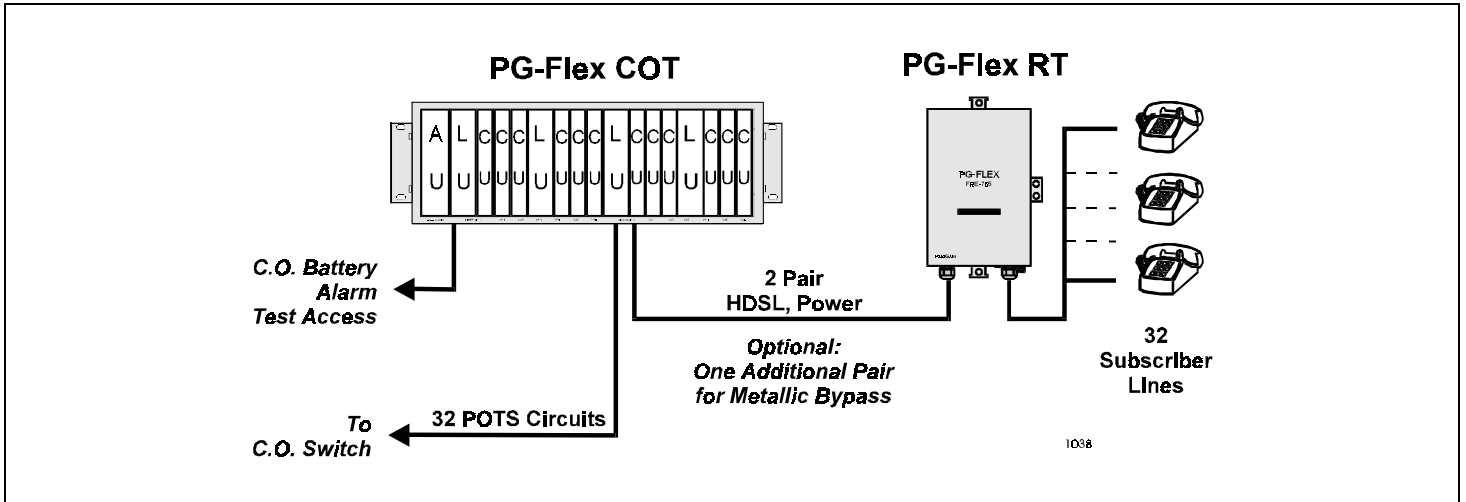

Figure 2. Typical PG-Flex Configuration.

TABLE 1. PG-FLEX DISTANCES

Wire Gauge	Loop Length	
	16/32 Channel System	Resistance
26 AWG (0.4 mm)	08.1 kft (2.5 km)	686Ω
24 AWG (0.5 mm)	10.7 kft (3.3 km)	569Ω
22 AWG (0.6 mm)	13.7 kft (4.2 km)	457Ω
19 AWG (0.9 mm)	19.4 kft (5.9 km)	322Ω

2.09 Test access may also be activated through the RS-232 Maintenance Port located on the front of the COT Line Unit, using an ASCII terminal.

3. SPECIFICATIONS

Analog Impedance

900 ohms

DC On-Hook Resistance

Greater than 4 megohms between Tip and Ring at the output of the COT

DC Off-Hook Current

30 mA

Channel Signature

FLC-704, List 1:

- Tip-Ring: 475 kohm, 1%
- Tip-Ground: 332 kohm, 1%
- Ring-Ground: (open)

COT 20-Hz Input Impedance

0.5 REN

COT Ring Detection

The COT recognizes a signal with an ac component of 65 V rms to 104 V rms @ 20 Hz ± 3 Hz superimposed on a dc component of -36 to -52.5 V dc applied to ring with respect to ground through a source impedance of less than 500 ohms as a ringing signal.

Operating Temperature & Humidity

-40° to +65° Celsius, 5% to 95% (non-condensing)

Operating Elevation

200 ft. (60 m) below sea level to 13,000 ft. (4,000 m) above sea level.

Dimensions

- Height: 6.75" (17.2 cm)
- Width: 1.00" (2.5 cm)
- Depth: 10.50" (26.7 cm)

Weight

0.8 lb. (0.4 kg)

4. CERTIFICATION

4.01 FCC Compliance. The FLC-704 Channel Unit complies with the limits for Class A digital devices pursuant to Part 15 of the FCC rules. These limits are designed to provide reasonable protection against harmful interference when the equipment is operated in a commercial environment. This equipment generates, uses and can radiate radio frequency energy and, if not installed and used in accordance with the instruction manual, may cause harmful interference to radio communications. Operation of this equipment in a residential area is likely to cause harmful interference in which case the user will be required to correct the interference at his own expense.

4.02 Refer to the installation section of the appropriate instruction manual for the unit you are installing to get information on:

- Cabling
- Proper connections
- Grounding
- Line power

4.03 All wiring external to the product(s) should follow the provisions of the current edition of the National Electrical Code.

5. WARRANTY

5.01 PairGain Technologies warrants this product to be free of defects and to be fully functional for a period of 5 years from the date of original shipment, given proper customer installation and regular maintenance. PairGain will repair or replace any unit without cost during this period if the unit is found to be defective for any reason other than abuse or improper use or installation.

5.02 This module should not be field repaired. If it fails, replace it with another unit and return the faulty unit to PairGain for repair. Any modifications of the unit by anyone other than an authorized PairGain representative will void the warranty.

5.03 If a unit needs repair, call PairGain for a Return Material Authorization (RMA) number and return the defective unit, freight prepaid, along with a brief description of the problem, to:

PairGain Technologies, Inc.
14402 Franklin Avenue
Tustin, CA 92780
ATTN: Repair and Return Dept.
(800) 638-0031

5.04 PairGain will continue to repair faulty modules beyond the warranty program at a nominal charge. Contact your PairGain sales representative for details and pricing.

B. FUNCTIONAL DESCRIPTION

6. OPERATIONAL CAPABILITIES

6.01 The FLC-704 Channel Unit provides 8 POTS interfaces to the CO switch. The card performs the interface function between the analog POTS circuit and the internal digital PCM bus. In addition, each card:

- Converts analog signals to 64 kbps A-Law PCM digital format
- Detects ringing voltage
- Detects forward disconnect
- Detects a subscriber test access signal
- Detects metering tones
- Provides loop closure

6.02 A block diagram of the FLC-704 Channel Unit is shown in Figure 3. One 8-Channel COT Channel Card supports eight POTS interfaces.

6.03 A status LED is associated with each line to indicate whether the line is off-hook, idle, ringing, or being tested. A common fault LED indicates a general fault has been detected on the card and it should be replaced.

6.04 Test access connections to a specific line circuit are made through the maintenance terminal or by the CO switch applying the appropriate voltages on the subscriber line (see paragraphs 2.06 through 2.09).

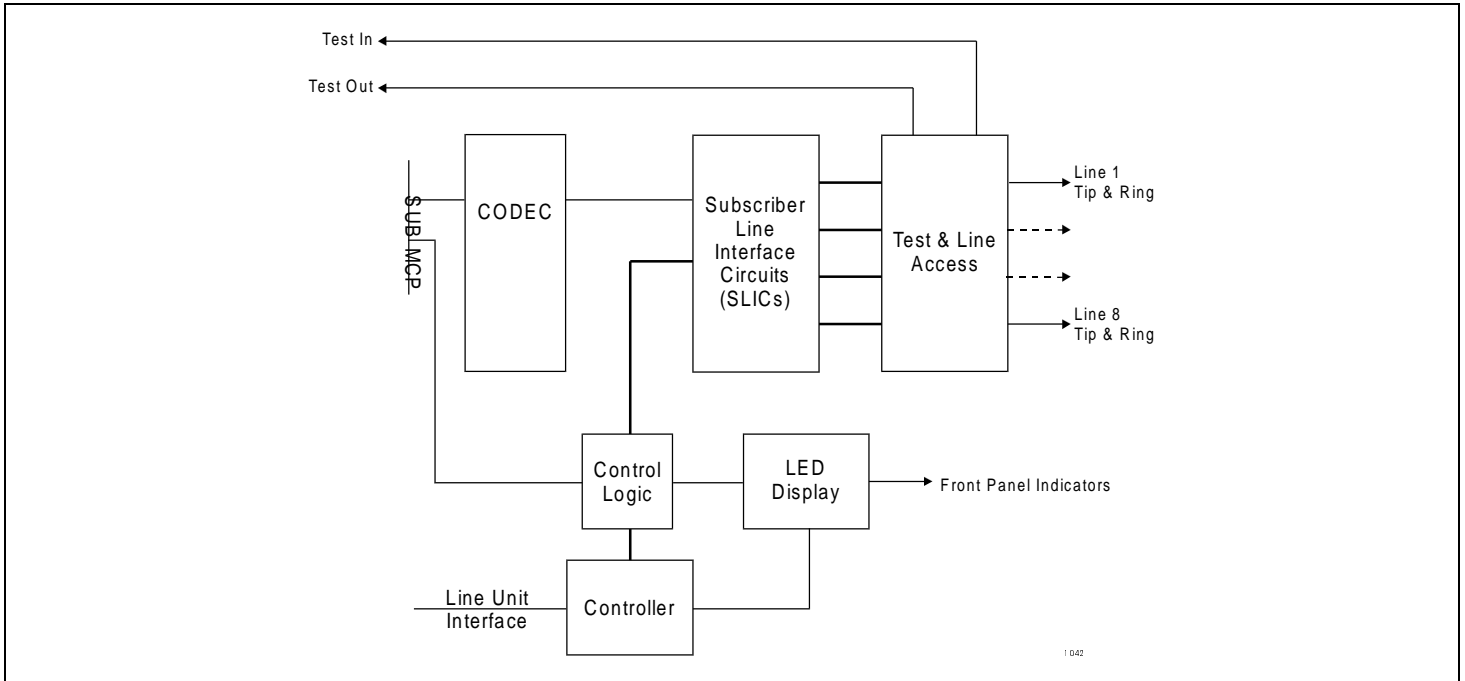

Figure 3. FLC-704 Block Diagram.

7. FRONT PANEL

7.01 The front panel of the FLC-704 Channel Unit contains the following indicators (see Figure 1):

- **ACTIVE 1-8 LED Indicators**
Green—the channel is off-hook.
Flashing Green—(slow flash) the channel is ringing (the LED will track the ringing) or the line has been switched to the test pair.
Off—the channel is on-hook or not connected.
- **FAULT LED Indicator**
Red—a fault has been detected by the unit.
Off—no faults are detected by the unit.

C. INSTALLATION AND TEST

8. UNPACKING

8.01 Upon receipt of the equipment, proceed as follows:

1. Unpack each container and visually inspect it for signs of damage. If the equipment has been damaged in transit, immediately report the extent of damage to the transportation company and to PairGain. Order replacement equipment if necessary.
2. Check the contents versus the packing list to ensure complete and accurate shipment. If the shipment is short or irregular, contact PairGain as described in Section 5. If you must store the equipment for a prolonged period, store the equipment in its original container.

9. TURN-UP AND TESTING

9.01 Table 2 provides step-by-step turn-up and test procedures for the FLC-704 Channel Unit.

10. TROUBLESHOOTING

10.01 Table 3 provides troubleshooting procedures based on indications displayed by the front panel indicators of FLC-704 Channel Unit.

TABLE 2. FLC-704 CHANNEL UNIT TURN-UP AND TESTING

CAUTION			
Observe normal electrostatic discharge precautions when handling electronic equipment. Do not hold electronic plug-ins by their edges. Take care not to touch components or circuitry.			
Step	Operation	Action	Observe
1	Install COT Channel Units	a. Insert each FLC-704 Channel Unit into the COT Shelf.	All LEDs on the Channel Unit will turn <i>on</i> for approximately ½ second, then scan from top to bottom, then flash all <i>on</i> , then <i>off</i> .
		b. After the system has powered up, established HDSL synchronized communications, and no calls are in progress, observe the Channel Unit front panel indicators.	ACTIVE 1 <i>off</i> ACTIVE 2 <i>off</i> ACTIVE 3 <i>off</i> ACTIVE 4 <i>off</i> ACTIVE 5 <i>off</i> ACTIVE 6 <i>off</i> ACTIVE 7 <i>off</i> ACTIVE 8 <i>off</i> FAULT <i>off</i>
2	Test Subscriber Circuits	a. Test each subscriber circuit by placing and receiving calls.	ACTIVE 1 through 8 LEDs track call progress as described in paragraph 7.01.

TABLE 3. FLC-704 CHANNEL UNIT TROUBLESHOOTING

Indication	Problem	Action
FAULT LED on	The processor in the Channel Unit has stopped.	Remove and re-insert the Channel Unit. If the system does not restart, replace the Channel Unit.
Troubleshooting based on customer-originated trouble reports		
No Dialtone, Can't Dial	Short circuit, faulty COT Channel Unit, or faulty RT Channel Unit.	<ol style="list-style-type: none"> Lift the subscriber pair at the RT. If dialtone is present at the RT and calls can be placed, check for shorts toward the subscriber or on the customer's premises. If you cannot hear a dialtone and/or cannot make calls at the RT with the subscriber drop lifted, lift the jumper in the CO between the CO switch and the COT. If you hear a dialtone and/or can make calls at the switch, try listening for dialtone on another subscriber pair on a different RT Channel Card. If dialtone is present on another pair, then replace the COT Channel Unit and/or RT Channel Unit. If dialtone is not present on the second subscriber pair, replace COT on RT Line Unit. Otherwise, the problem is in the CO switch.
Phone Doesn't Ring	High-resistance short on subscriber drop, faulty RT Channel Unit, or faulty RT Line Unit.	<ol style="list-style-type: none"> Check for ringing at the RT. If ringing isn't present on the line under test, try ringing another line terminated on the same RT Channel Unit. If ringing is present on other lines, check for high resistance shorts on the subscriber drop. If no high resistance shorts, replace the RT Channel Unit. If ringing isn't present on a circuit terminated on the same RT Channel Unit, try ringing a line terminated on another RT Channel Unit. If the line rings, replace the RT Channel Unit. If the line doesn't ring, replace the RT Line Unit.
Phone Doesn't Stop Ringing	Faulty subscriber station instrument, faulty RT Channel Unit, or loop length too long.	<ol style="list-style-type: none"> Phone stops ringing when using a butt-in at subscriber location: <ol style="list-style-type: none"> Subscriber's station instrument's internal resistance is too high. Replace instrument according to local policies. If phone doesn't stop ringing when using a butt-in at the subscriber location, re-test at the RT: <ol style="list-style-type: none"> If phone still doesn't stop ringing, replace the RT Channel Unit. Otherwise, loop length between RT and subscriber is too long.
Can't Hear, Can't Be Heard	Subscriber problem, faulty COT Channel Unit, or faulty RT Channel Unit.	<ol style="list-style-type: none"> Lift the subscriber drop at the RT. If audible level is acceptable, there is a problem toward the subscriber. If audible level is too low at the RT with the subscriber drop lifted, lift the jumper in the CO between the CO switch and the COT. If audible level is acceptable, replace the COT Channel Unit and/or RT Channel Unit. Otherwise, the problem is in the CO switch.