

# PAIRGAIN™ TECHNOLOGIES HIGAIN™ LINE UNIT MODEL ELU-319 Issue 1

List 1, PairGain #150-1236-01

List 2, PairGain #150-1236-02

List 3, PairGain #150-1236-03

List 4, PairGain #150-1236-04

CONTENTS	PAGE
A. PRODUCT OVERVIEW	2
1. DESCRIPTION AND FEATURES	2
2. APPLICATIONS	2
3. SPECIFICATIONS	3
4. CERTIFICATION	3
5. WARRANTY	3
B. FUNCTIONAL DESCRIPTION	4
6. OPERATIONAL CAPABILITIES	4
7. SYSTEM PARAMETER SETTINGS	6
8. MAINTENANCE PORT OPERATION	8
9. LOOPBACK DESIGN DESCRIPTION	8
C. INSTALLATION AND TEST	9
10. INSTALLATION OPTIONS	9
11. TESTING PROCEDURES	10

**CAUTION**

This product incorporates static sensitive components.  
Proper electrostatic discharge procedures must be  
followed.

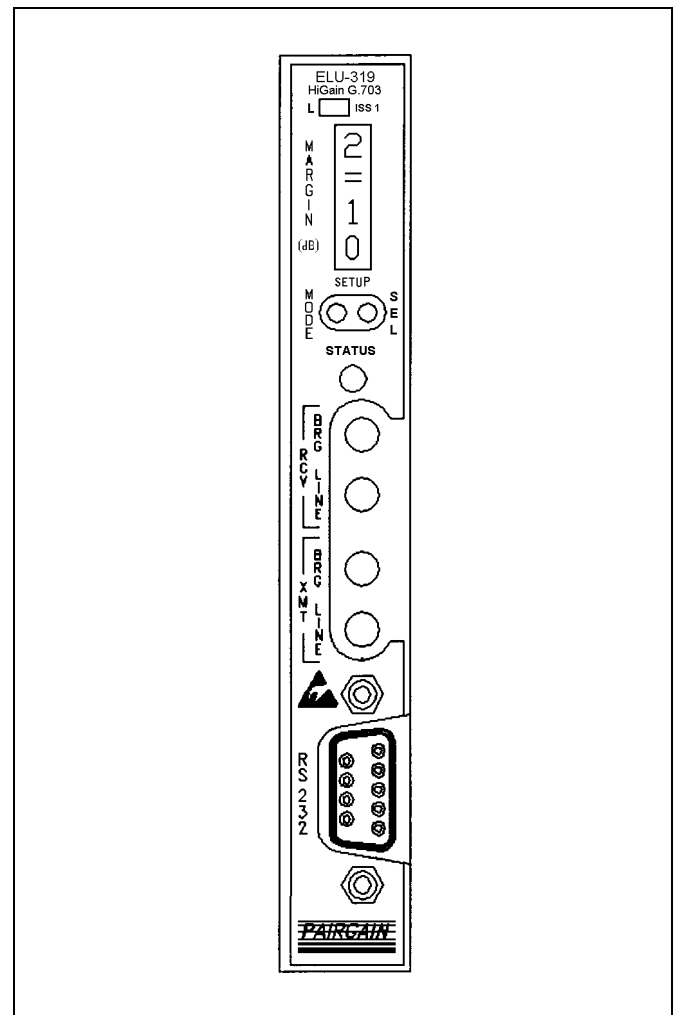

**Figure 1. ELU-319 Front Panel.** The PairGain ELU-319 is the local unit used in conjunction with the ERU-412 remote unit to provide a complete HiGain HDSL system.

**A. PRODUCT OVERVIEW**

**1. DESCRIPTION AND FEATURES**

**1.01** PairGain's HiGain Line Units Model ELU-319, Lists 1, 2, 3, and 4 (Figure 1), are the Public Exchange side of a repeaterless G.703 transmission system. When used with an ERU-412 HiGain Remote Unit (ERU), the system provides 2.048 Mbps transmission on two unconditioned copper pairs. The system's range is 35 dB @ 260 kHz @ 135 ohms inclusive of bridge taps and gauge changes. The HiGain system uses HDSL (High-bit-rate Digital Subscriber Line) transmission technology as recommended by Bellcore TA-TSY-001210. HiGain complies with TR-TSY-000063 (Network Equipment Building System (NEBS) Generic Equipment requirements) and TR-TSY-000499 (Transport System Generic Requirements—TSGR) common requirements.

**1.02** Revision History of this practice.

**Revision 01—April 5, 1995**

a) Initial release.

**1.03** The ELU-319 is compatible with the PairGain 22-slot HMS-318 shelf and the associated G.703 HiGain connector panel HCP-322.

**1.04** ELU-319 Product Family:

- List 1: 75-ohm G.703 impedance, no line power
- List 2: 120-ohm G.703 Impedance, no line power
- List 3: 75-ohm G.703 Impedance, line power
- List 4: 120-ohm G.703 Impedance, line power

**1.05** ELU-319 Issue 1 features:

- List 3 and 4: -130V dc line power for ERU-412
- Four-digit front panel display for HDSL signal/noise (S/N) margin configuration and alarms
- Compatible with Span Terminating Shelf (STS) high-density shelves.
- RS-232 maintenance port
- Non-volatile configuration memory
- Front panel G.703 splitting and bridging access
- Lightning and power cross protection on HDSL interfaces

- 1040 kbps full-duplex two-bits one-quaternary (2B1Q) HDSL transmission on each of two pairs
- Front panel status-indicating light-emitting diode (LED) indicator
- On / Off front-panel display power cycling
- G.703 Loss of Signal (LOS) detector (125 consecutive zeros)
- Margin threshold alarm
- Single step default setting
- Circuit ID option

**2. APPLICATIONS**

**2.01** The HiGain System provides a cost-effective, easy to deploy method for delivering G.703 High Capacity Digital Service (HCDS) over metallic pairs. The fiber-like quality service is deployed over two unconditioned, non-loaded copper pairs. Conventional span repeaters are not required. Cable pair conditioning, pair separation and bridged tap removal, are also not required.

**2.02** The HiGain system operates with any number of other G.703, Plain Old Telephone System (POTS), digital or analog data service or other HiGain Systems sharing the same cable binder group. HiGain provides a means of quickly deploying service in advance of fiber-optic transmission systems. By using HiGain G.703, you can connect service within a few days or even a few hours. You can install fiber optic systems at a leisurely pace and cut-over from HiGain when the time allows. You can then easily remove the HiGain and utilize it elsewhere.

**2.03** The general guidelines require that each HDSL loop have less than 35 dB of loss at 260 kHz, with 135-ohm driving and terminating impedances.

**2.04** The following table provides a guide for the loss of various cable gauges at 260 kHz and 135 ohms. The table applies to the HDSL cable pairs between the ELU and ERU. Add 3 dB for each bridged tap and 1dB for each cable gauge change.

**TABLE 1. HDSL LOSS OVER CABLES**

Cable Gauge	Loss @ 260 kHz(db/km)	Ohms per km
26/0.4mm	13.94	272
24/0.51mm	10.47	171
22/0.61mm	8.14	105
19/0.91mm	5.74	52

### 3. SPECIFICATIONS

#### HDSL Line Code

1040 kbps, 2B1Q

#### HDSL Output

+13.5 dBm  $\pm$  0.5 dB @ 135 ohms

#### HDSL Line Impedance

135 ohms

#### Maximum Provisioning Loss

35 dB @ 260 kHz, 135 ohms

#### Line Clock Rate

Internal Stratum 4 clock

#### HDSL Startup Time

30 seconds (typical), 60 seconds (maximum)

#### One-way G.703 Delay

Less than 220 microseconds

#### G.703 Line Impedance

List 1 and 2: 75 ohms  
List 3 and 4: 120 ohms

#### G.703 Input Level

+1.5 to -7.5 dB<sub>DSX</sub>

#### G.703 Line Rate

2.048 Mbps  $\pm$  200 bps

#### G.703 Line Format

HDB3

#### Power Consumption

14 watts (typical), 18 watts (maximum)

#### Heat Dissipation

6 watts (typical), 8 watts (maximum)

#### Fusing

Internal, 1.25A @ 125V; connected to FUSEALARM output on pin 10

#### Span Voltage

-136V dc  $\pm$  4V dc

#### Margin Indicator

Displays span SNR margin for both spans relative to 10<sup>-7</sup> BER operation

#### Electrical Protection

Secondary surge protection on G.703 and HDSL ports

Power cross protection on HDSL ports

#### Operating Temperature and Humidity

-40 to 65° Celsius, 5 to 95% (non-condensing)

#### Mounting

STS, 28-slot, high-density shelf

#### Dimensions

Height: 4.75" (12.07 cm)

Width: 0.7" (1.78 cm)

Depth: 10.5" (26.67 cm)

### 4. CERTIFICATION

**4.01** FCC compliance: The ELU-319 has been tested and found to comply with the limits for Class A digital devices pursuant to Part 15 of the FCC rules. These limits are designed to provide reasonable protection against harmful interference when the equipment is operated in a commercial environment. This equipment generates, uses and can radiate radio frequency energy and, if not installed and used in accordance with the instruction manual, may cause harmful interference to radio communications. Operation of this equipment in a residential area is likely to cause harmful interference in which case the user will be required to correct the interference at his own expense.

### 5. WARRANTY

**5.01** PairGain Technologies warrants this product to be free of defects and to be fully functional for a period of 36 months from the date of original shipment, given proper installation. PairGain will repair or replace any unit without cost during this period if the unit is found to be defective for any reason other than abuse or improper use or installation.

**5.02** This module should not be field repaired. If it fails, replace it with another unit and return the faulty unit to PairGain for repair. Any modifications of the unit by anyone other than an authorized PairGain representative voids the warranty.

**5.03** If a unit needs repair, call PairGain for a Return Material Authorization (RMA) number and return the defective unit, freight prepaid, along with a brief description of the problem, to:

**PairGain Technologies, Inc.**  
**14402 Franklin Avenue**  
**Tustin, CA 92680**  
**ATTN: Repair and Return Dept.**  
**(800) 638-0031**

**B. FUNCTIONAL DESCRIPTION**

**6. OPERATIONAL CAPABILITIES**

**6.01** HiGain utilizes PairGain's 2-Bits-1-Quaternary (2B1Q) HDSL transceiver systems to establish two full-duplex 1040 Kbps data channels between the ELU-319 and an ERU-412 HiGain Remote Unit. This provides a total capacity of 2.048 Mbps between the two units.

**6.02** A block diagram of the ELU-319 is shown in Figure 2. The HiGain ELU-319 receives a 2.048-Mbps data stream from the G.703 digital cross-connect interface.

**6.03** The ELU-319 contains a demultiplexer that generates two parallel 1040 kbps data streams. Each data stream consists of HDSL frames that are nominally 4704 bits (4.5 milliseconds) in length. Each frame contains a 14-bit Frame Sync Word (FSW), a 6-bit Cyclic Redundancy Check (CRC), a 21-bit operations channel and 16 of the 32 timeslots in the G.703 stream. The demultiplexer provides frame synchronization for each of the two HDSL channels. The multiplexer and HDSL transceivers work under control of the ELU-319 microprocessor and compensate for data inversions caused by tip-ring reversals and for channel swaps caused by pair reversals. The HiGain system allows

for tip-ring or pair reversals, but does not tolerate split pairs.

**6.04** The two formatted HDSL channels pass to the HDSL transceivers, which convert them to 2B1Q format. The 2B1Q line code operates in full-duplex mode on unconditioned pairs. The transceiver's digital echo cancelers and adaptive equalizers receive the signal from the remote end in the presence of impairments and noise on the copper pairs. HDSL channel 1 contains G.703 timeslots 1 through 16. HDSL channel 2 contains G.703 timeslots 17 through 32.

**6.05** The transceiver processes the HDSL channels it receives and passes them on to the ELU-319 multiplexer. The multiplexer removes data link messages from the HDSL channels and passes them to the microprocessor. This enables the ELU-319 and the ERU-412 Remote Unit to exchange operations messages and status. By synchronizing to the FSW of each channel, the multiplexer can reconstruct the original 2.048 Mbps G.703 stream from the payloads of the two HDSL channels. The CRC fields on the HDSL streams enable the ELU-319 to determine if errors are present on the channel due to excessive impairments caused by impulse or crosstalk noise.

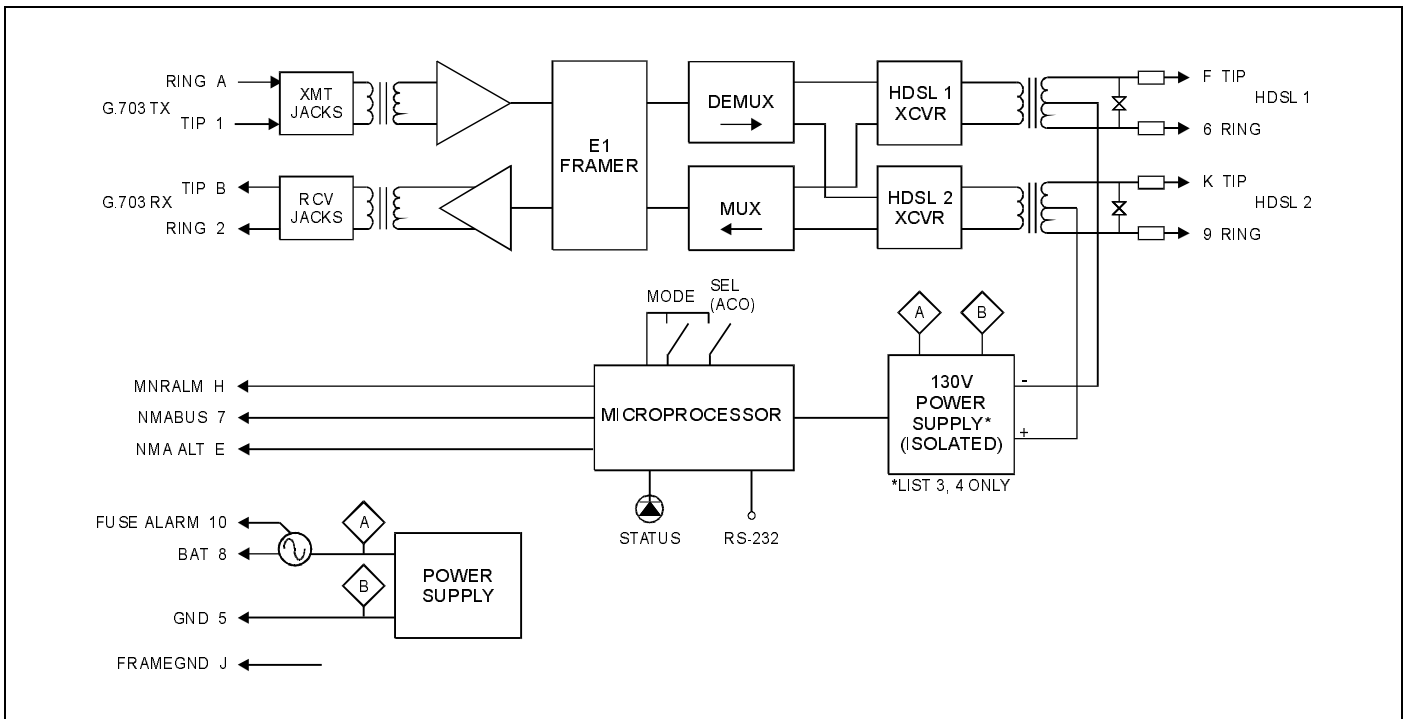

**Figure 2. ELU-319 Block Diagram.** PairGain's HDSL technology provides full-duplex services at 2.048 Mbps over copper wires between an ELU-319 and an ERU-412, which comprise one HiGain system.

- 6.06** The reconstructed HDSL data channel is buffered in a first-in-first-out (FIFO) buffer within the multiplexer. A frequency synthesizer in conjunction with the buffer regulates the output bit rate and reconstructs the G.703 clock at the exact rate received from the remote end. The HiGain system operates at G.703 rates of 2.048 Mbps with up to  $\pm 50$  ppm of offset.
- 6.07** A G.703 interface driver converts the G.703 channel to a High Density Bipolar 3 (HDB3) format.
- 6.08** The transmit and receive G.703 ports have splitting access and bridging "Bantam"-type jacks. Connecting one cable between the two BDG jacks and another between the two LINE jacks splits the XMT and RCV and creates metallic loopbacks towards both the customer equipment and the HDSL line.
- 6.09** The ELU-319 contains two separate power converters. The main power supply converts -48V local battery to logic power for the ELU-319 circuits. The line power supply converts the -48V battery to a -130V feed that provides simplex power feed on the HDSL loops. The line power supply (List 3 and 4 only) can be turned on or off by the microprocessor and automatically shuts down in the presence of line short-circuits or microprocessor failure.
- 6.10** The three most important power demands of an ELU-319 on the shelf power supply are its maximum power consumption, its maximum power dissipation, and its maximum current drain. These three parameters for the ELU-319, on a per slot and per shelf basis, are as follows:

<i>Parameter</i>	<i>List 1 and 2</i>	<i>List 3 and 4</i>
<b>Maximum Power Dissipation</b>		
Per slot	6W	8.0W
Per shelf	132W	176W
<b>Maximum Power Consumption</b>		
Per slot	13W	18W
Per shelf	286W	396W
<b>Maximum Current Drain</b>		
Per slot	0.317A	0.423A
Per shelf	6.97A	9.3A

- 6.11** Note that the worst case conditions under which these parameters were measured include a 2.51-km, 0.4-mm loop, a fully loaded 22-slot shelf, and a -42.5V shelf battery voltage. The front panel display is assumed to be in its normally OFF state (paragraph 9.02). Assuming otherwise defeats the main purpose, power conservation, for having the display cycle on and off.
- 6.12** The Maximum Power Dissipation measures the power that is converted into heat build up within the unit. It contributes to the total heat generated in the space around the unit. It is used to determine the maximum number of fully loaded shelves per bay that does not exceed the maximum allowable power dissipation density in watts/square meter ( $W/m^2$ ).
- 6.13** The thermal loading limitations imposed when using the ELU-319 in controlled environmental vaults (CEVs) or other enclosures are determined by applying the ELU-319 power parameters to the manufacturer's requirements for each specific housing.
- 6.14** The Maximum Power Consumption is the total power the ELU-319 consumes or draws from its -48V shelf power source. This parameter is needed when the ELU-319 is located remote to its serving exchange. It determines the battery capacity required to maintain an 8-hour standby battery reserve for emergency situations. It thus limits the maximum number of plugs per remote enclosure. Use the above data to perform this analysis case by case.
- 6.15** The Maximum Current Drain is the maximum current drawn from the shelf power supply when it is at its minimum voltage (-42.5V). This determines the shelf fusing requirements. ELU-319 shelves have two separate 48V buses. Each bus is fused at 10A for a total of 20A per shelf. A fully loaded shelf with 22 ELU-319 units draws 9.3A in the worst case. This is well within the 20A fuse limit.
- 6.16** An RS-232 connector (DB-9) on the front panel provides access to HiGain maintenance, provisioning and performance monitoring interface. Basic functionality is available via a 'dumb terminal'. Refer to Section 8 for 'dumb' operation procedures.

**Section 150-319-200**  
**Revision 01**

**6.17** Pin H of the ELU-319 is the minor alarm (MNRALM) output pin. This pin must never operate above 0V or below -60V. The ELU-319 forces pin H to ground (maximum of 10 mA) for any of the conditions listed below, with the accompanying front panel message in bold letters. More than one alarm condition can exist at any given time, but the unit can display only one message. For multiple alarms, only the highest priority alarm appears. The alarms are listed in their order of priority:

- 1) **ALRM LOSW**: Loss of synchronization in either HDSL loop.
- 2) **ALRM LLOS**: Loss of ELU-319 G.703 input signal.
- 3) **ALRM RLOS**: Loss of ERU-412 G.703 input signal.
- 4) **ALRM H1ES**: HDSL Loop 1 exceeded the 24-hour user-selected Errored-Seconds threshold (refer to Section 7).
- 5) **ALRM H2ES**: HDSL Loop 2 exceeded the 24-hour user-selected Errored-Seconds threshold (refer to Section 7).
- 6) **ALRM G.703**: The total number of bipolar violations (BPV) at the ELU and ERU G.703 inputs exceeded the 24-hour user-selected threshold refer to Section 7).
- 7) **ALRM MAL1 (2)**: The margin on HDSL Loop 1 (Loop 2) has dropped below the Margin Alarm Threshold value set from the Maintenance Port menu (refer to Section 7).

**6.18** Pin H (MNRALM) of the ELU-319 remains grounded for the duration of the alarm condition. The ELU-319 **STATUS** LED flashes red for the duration of a minor alarm condition. You can retire the MNRALM by pressing the front panel **SEL**(ect) button, thus executing the alarm cut-off (ACO) option. This turns the alarm off and replaces the ALRM message with ACO. The part of the message that defines the alarm remains until the alarm condition clears or another alarm occurs. Disabling the ALM also retires an ACO condition.

**6.19** Setting the ALM option to DIS(able) only prevents the unit from activating the MNRALM output alarm bus on pin H on a minor alarm event. The **STATUS** LED still flashes red and the ALRM message still appears.

**6.20** The ELU-319 drives pin 10 (FUSEALARM) to -48V whenever its on-board fuse opens. Its normally floating output must never operate above ground or below -80V. It can sink a current of 10 mA.

**6.21** The ELU-319 Line Unit front panel tri-color **STATUS** LED has the following states:

- GREEN - Normal operation
- FLASHING GREEN - HDSL acquisition
- FLASHING RED - MNRALM (For conditions see paragraph 6.17)
- RED - FUSEALRM
- YELLOW - Self-test in process or an ELU-319 loopback in effect (CREM or Network Local Loopback (NLOC))

## **7. SYSTEM PARAMETER SETTINGS**

**7.01** The operating mode of the ELU-319 depends on the settings of the following system operating parameters:

- ESAL—Errored Seconds Alarm threshold
- LBTO—Loopback Timeout
- ALM—Minor Alarm
- MAL—Margin Alarm Threshold

**7.02** Table 1 lists the ELU-319 system parameters and their optional settings. The ELU-319 stores the settings of the system parameters in non-volatile RAM to prevent their loss in the event that shelf power is lost or the ELU-319 is unplugged.

**7.03** No DIP-switches or jumpers are required to set the ELU-319 configuration. You can set the ESAL, LBTO, and MAL system parameter options with the front panel pushbuttons (**MODE** and **SEL**); you can set all parameters from the maintenance terminal through the ELU-319 RS-232 interface as described in Section 8.

**7.04** To initiate the Option Set mode from the ELU-319 front panel, press and hold the **MODE** button for one second. The front panel message alternates between the system parameter and its current setting. Press the **SEL** button to step through all possible values (in sequence) of the parameter being displayed. Press **MODE** when the desired setting is displayed. This selects the next configurable parameter. When you have selected the last parameter, the display displays "CONF/NO". To return to original settings, press the **MODE** button. To accept the new settings, press the **SEL** button. This displays "CONF/YES", installs the changes, and returns to normal display mode. If you do not press either button within 30 seconds, the parameters return

to their original values, and the display returns to normal mode.

**7.05** To set all parameters to their default values, press and hold the **SEL** button for six or more seconds. The message "DFLT/NO" appears when you release the button. Press **SEL** again to display "DFLT/YES" and accept the default values. Press **MODE** to cancel and return to the original values.

**7.06** Press the **MODE** button for 3 or more seconds to scroll through the ELU-319 software version number, List #, and all parameter option settings.

**TABLE 1. SYSTEM PARAMETER OPTION SETTINGS**

<i>Parameter</i>	<i>Option</i>	<i>Description</i>
ESAL (Errored Seconds Alarm Threshold)	17	Activates MNRALM (on pin H) after 17 Errored Seconds (17 HDSL CRC errors on either HDSL loop or a total of 17 BPVs and FERR) occur within 24 hours.
	170	Activates MNRALM (on pin H) when 170 Errored Seconds occur within 24 hours.
	NONE*	Prevents generation of a minor alarm due to excessive Errored Seconds.
LBTO (Loopback Timeout)	NONE	Disables automatic time-out cancellation of all loopbacks.
	20	Sets automatic cancellation of all loopbacks to 20 minutes after initiation.
	60*	Sets automatic cancellation of all loopbacks to 60 minutes after initiation.
	120	Sets automatic cancellation of all loopbacks to 120 minutes after initiation.
ALM (Minor Alarm)	DIS*	Retires an existing minor alarm on pin H by disabling its signal, and prevents another minor alarm from occurring.
	ENA	Enables pin H to be grounded when a minor alarm condition occurs.
CONF (Confirm)	YES	Confirms that all 4 operating modes are to be updated to their current choices.
	NO*	Prevents the most recently selected operating mode choices from being updated. They remain as they were prior to entry of system option settings procedure.
MAL (Margin Alarm Threshold)	0 to 15	Displays the Margin Alarm Threshold (in dB), set using the RS-232 Maintenance port. If the margin on either loop drops below this value, a minor alarm is reported (MAL1 or MAL2). The factory Default is 4.
	4*	

\* Indicates the ELU-319 factory settings.

## 8. MAINTENANCE PORT OPERATION

**8.01** To configure the ELU-319 from the Maintenance port, connect an ASCII display terminal to the RS-232 Maintenance port with a cable configured as shown in Figure 3. The maintenance port is configured as Data Communications Equipment (DCE) with 8 data bits, 1 stop bit and no parity. Striking the SPACE bar several times invokes the “autobaud” function over a range of 1200 to 4800 bps.

**8.02** The menus and informational screens displayed by the terminal are shown in Figures 7 through 14. From the Main Menu (Figure 7), select C–SYSTEM SETTINGS. Entering the letter in parenthesis of the parameter you want to change scrolls the parameter through its options. When you have made the new settings, enter C to confirm.

**8.03** Two user settings, Circuit ID, and Margin Alarm Threshold, must be set from the display terminal.

**8.04** To set the Circuit ID, select H from the Main Menu to display “Enter circuit ID # (24 characters max)”. Enter the circuit ID, press ENTER, then press C to confirm the entry. If you enter more than 24 characters, the terminal beeps and accepts only the first 24 characters. The circuit ID appears in all screens, and you cannot reset it to a default as described in paragraph 7.05.

**8.05** To set the Margin Alarm Threshold, select G–SYSTEM SETTINGS and then select G–MAR(G)IN ALM THRES. Enter the minimum acceptable alarm threshold, from 0 to 15 dB. If the margin for HDSL Loop 1 or 2 drops **below this value**, the ELU-319 triggers a minor alarm, and the front panel and status screen displays “MAL1” (Loop 1) or “MAL2” (Loop 2). Because a margin can never be less than zero, setting a threshold of zero turns this feature off.

**8.06** To set the Clock, select B–SET CLOCK from the Main Menu. Enter the new date and time. Press U to update the ERU system time and date.

**8.07** The Maintenance Port also provides several screens that display System Performance and Alarm Status information. Figures 11 through 13 illustrate these screens. Table 4 defines the terms used in the Alarm and System Setting screens. The illustrations of the System Setting and ELU Status screens show factory defaults with optional values or settings in parentheses.

## 9. LOOPBACK DESIGN DESCRIPTION

**9.01** All HiGain ELU/ERU system loop-up codes must be initiated from either the front panel pushbuttons or from the maintenance terminal. The HiGain system does not respond to any **in-band codes**.

**9.02** Pressing both the **MODE** and **SEL** pushbuttons on the front panel for at least three seconds initiates a manual loopback session. This session allows the user to select one of four HiGain loopbacks shown in Figure 4. The message “MAN LPBK” appears on the front panel display followed by the message “NLO?”. If **SEL** is pressed, an NLOC loopback is executed and the message changes from “NLO?” to “NLOC”. If **MODE** is pressed instead of **SEL** button, “NLO?” is replaced by “NRE?”, allowing a NREM to be executed by pressing **SEL**. Pressing **MODE** two more times yields the CLO? (CLOC) and CRE? (CREM) customer loopback options respectively. This interactive button procedure permits any of the four HiGain loopback options to be executed. Once a loopback option is executed, it can be terminated and the next loopback option presented by pressing **MODE**. If neither button is pressed for 30 seconds and no loopback is in effect, this manual loopback session terminates and the normal margin displays reappear. If any loopback is active, this 30-second time-out is inhibited; the active loopback and the manual loopback session continue until the loopback times out in accordance with the user LBTO

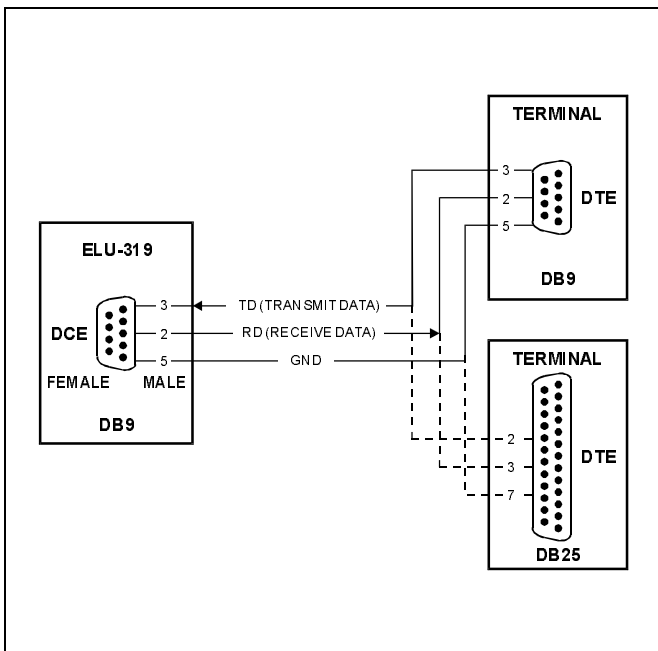

**Figure 3. ELU-319 DB-9 Pin-Outs.** A standard RS-232 (DB-9) connector on the front panel provides access to the menu interface feature via a dumb terminal.



setting. Only one loopback may exist at any given time. Pressing both buttons for three seconds terminates any active loopback, ends the MANUAL loopback session, and returns the display to normal.

**9.03** Note that these same four loopbacks can be initiated from the RS-232 maintenance port by selecting 'D' LOOP-BACK mode from the main menu. This displays the Loopback Menu, shown in Figure 14, from which you can initiate any of the four loopbacks.

**C. INSTALLATION AND TEST**

**10. INSTALLATION OPTIONS**

**10.01** Upon receipt of equipment, visually inspect it for signs of damage. If the equipment has been damaged in transit, immediately report the extent of damage to the transportation company and to PairGain Technologies.

**10.02** The ELU-319 is designed to mount in the high density STS or equivalent. The ELU-319 slot pin-outs are shown in Figure 5.

G.703 TX - T	A	■	■	1	G.703 TX - R
G.703 RX - T	B	■	■	2	G.703 RX - R
	C	□	□	3	
	BUS	D	□	4	
	NMA ALT	E	□	5	GND
HDSL - 1 TX	F	■	■	6	HDSL - 1 RX
	MNRALM**	H	■	7	NMA BUS
	FRAME GND	I	■	8	-48 V
HDSL - 2 TX	K	■	■	9	HDSL - 2 RX
	L	□	■	10	FUSE ALARM*

\*FUSE ALARM: Normal = 0 to -60 VDC Max.  
Activated = -48 VDC, 10 mA Max.

\*\*MNRALM: Normal = 0 to -60 VDC Max.  
Activated = Ground, 10 mA Max.

**Figure 5. ELU-319 Pin-Outs.** The active pins are highlighted in black in this illustration.

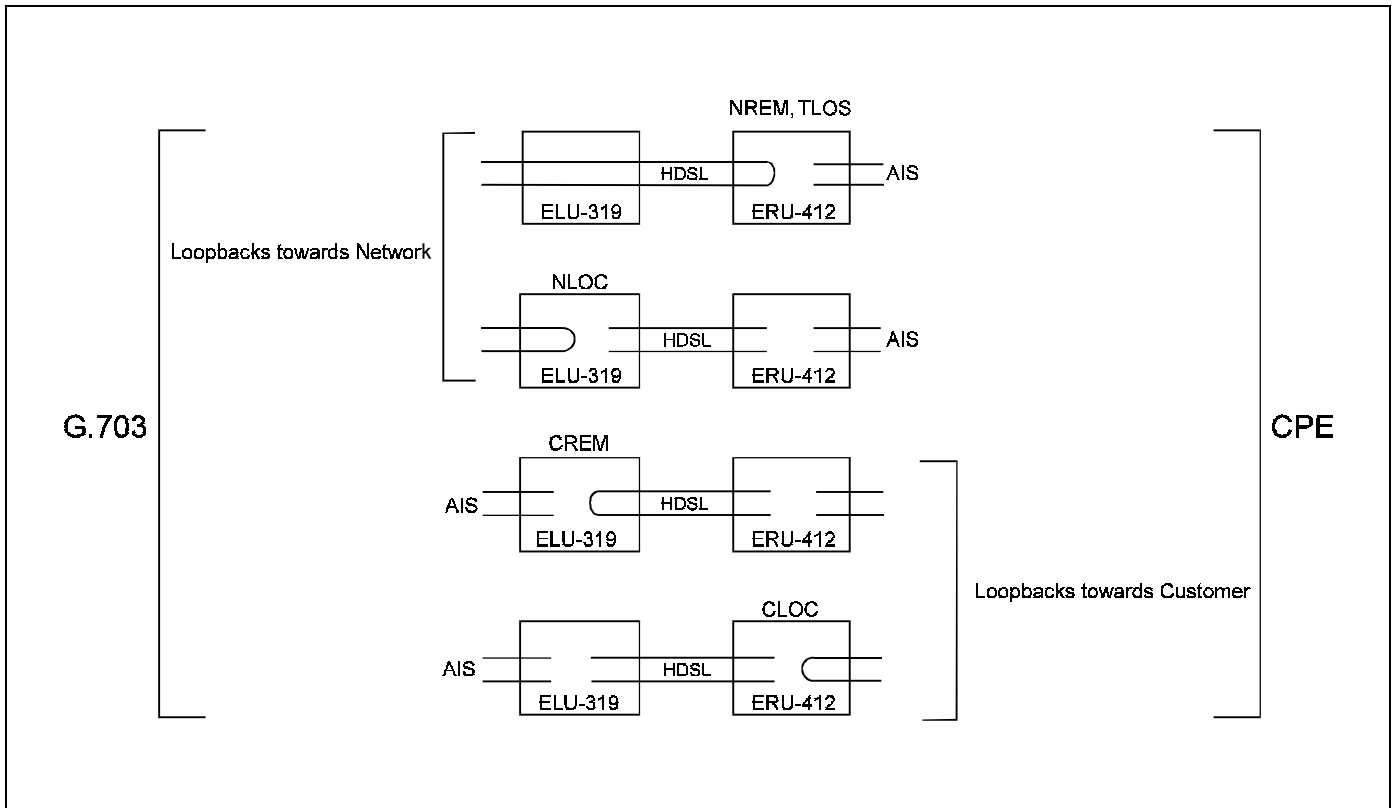

**Figure 4. ELU-319 Loopback Configurations.** All loopbacks are initiated from the front panel pushbuttons or from the maintenance terminal.

## 11. TESTING PROCEDURES

**11.01** Table 2 lists the four-character front panel message displays of the ELU-319. This display energizes when power is initially applied to the ELU-319; it indicates system status and error conditions. In order to conserve power, the display de-energizes after five minutes if neither **MODE** or **SEL** are pressed. The use of either button restarts the 5-minute power-control timer.

**11.02** If you encounter trouble with the G.703 interface, verify that the unit is making a positive connection with the mounting assembly's connector.

**11.03** The transmit and receive G.703 ports have splitting access and bridging miniature 210-type jacks as shown in Figure 6. Connecting one cable between the two BRG jacks and another cable between the two SPAN jacks splits the XMT and RCV jacks and creates metallic loopbacks towards both the G.703 and the ELU-319.

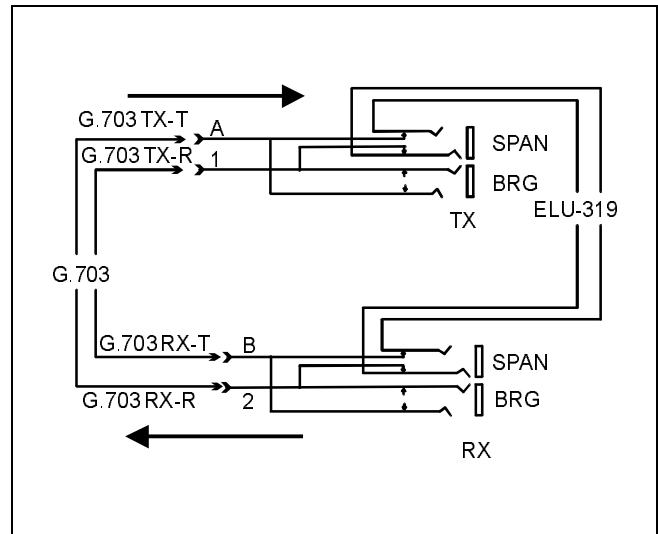

**Figure 6. Splitting and Bridging Jacks.** These jacks are used to create metallic loopbacks towards both the G.703 and ELU-319.

**TABLE 2. ELU-319 FOUR-CHARACTER FRONT PANEL MESSAGES**

<i>Message</i>	<i>Full Name</i>	<i>Description</i>
CREM	Customer Remote Loopback	Signal from customer is looped back to customer at ELU-319.
NLOC	Network Local Loopback	G.703 signal is looped back to G.703 at ELU-319.
CLOC	Customer Local Loopback	Signal from Customer is looped back to customer at ERU-412.
NREM	Network Remote Loopback	G.703 signal is looped back to G.703 at the ERU-412.
TLOS	Transmit Loss Of Signal	ERU-412 is in a logic loopback state caused by a loss of its G.703 input from the NI, if enabled via the ERU-412 TLOS switch option set to <b>ON</b> .
LBPV	Local Bipolar Violation	A bipolar violation has been received at the g.703 input to the ELU-319.
SIG 1 or 2	Signal 1 or Signal 2	The ELU-319 and ERU-412 transceivers are trying to establish contact with each other.
ACQ 1 or 2	Acquisition 1 or Acquisition 2	The ELU-319 and ERU-412 multiplexers are trying to establish synchronization over each loop.
H1ES		HDSL CRC error on Loop 1 of the ELU-319.
H2ES		HDSL CRC error on Loop 2 of the ELU-319.
ACO	Alarm CutOff	An MNRALM has occurred, and was retired to an ACO condition by pressing the <b>SEL</b> button on the ELU-319 front panel.

*Table continued on next page*

**TABLE 2. ELU-319 FOUR-CHARACTER FRONT PANEL MESSAGES (CONTINUED)**

<i>Message</i>	<i>Full Name</i>	<i>Description</i>
SELF TEST		The ELU-319 is in a self test mode. This occurs every power ON/OFF cycle. The self-test sequence includes the input G.703 transceiver chip when the HDSL loops are not in sync. This can cause the AIS pattern, normally transmitted from the ELU during this time, to exhibit bipolar violations (BPVs).
ALRM	Alarm Condition Exists	A minor alarm MNRALM condition is in effect.
1=xx or 2=yy	HDSL Loop Margins	Indicates the worst-case signal-to-noise ratio measured for each loop. A value of '06' or greater is adequate for reliable system operation.
PWR FEED SHRT	Power Feed Short	Indicates a short-circuit between the two HDSL pairs, or the ERU-412 cannot communicate with the ELU-319 over good cable.
PWR FEED OPEN	Power Feed Open	Indicates an open circuit in the Tip and Ring of either HDSL pair.
BAD RT?	No response from ERU	The ELU-319 does not receive any response from the ERU-412. Thus, the ERU's integrity is questionable.
VER	ELU Software Version #	This is displayed during the System Settings review mode. Press the Mode button for 3 seconds.
LIST 0xL	ELU's List #	Displayed during System Settings review mode defined above.
LOSW	Loss of Sync Word	Indicates that one of the HDSL loops has lost synchronization. Causes a minor alarm.
LLOS	Local Loss of Signal	Indicates that no signal is detected at the G.703 input to the ELU-319. Causes a minor alarm.
RLOS	Remote Loss of Signal	Indicates that no signal is detected at the G.703 input to the ERU-412. Causes a minor alarm.
G.703	G.703 BPV errors	Indicates that the number of BPVs at the ELU-319 and ERU-412 G.703 inputs that have exceeded the 24-hour ES threshold. Causes a minor alarm.
MAL1(2)	Margin Alarm Loop 1 or 2	The margin on HDSL loop 1 (2) has dropped below the threshold (1 to 15 dB) set by the user.

**TABLE 3. ELU-319 STATUS MENU DEFINITIONS**

<i>Message</i>	<i>Full Name</i>	<i>Description</i>
<b>ALARMS</b>		
NONE	No Alarms	
LLOS	Local Loss of Signal	No signal from local G.703 interface.
RLOS	Remote Loss of Signal	No signal from remote G.703 interface.
MNR	Minor Alarm	A Minor Alarm condition exists.
LOSW	Loss of (HDSL) Sync Word	One or both of the HDSL loops has lost internal framing-word synchronization.
H1ES	HDSL Loop 1 Errored Second	The number of Loop 1's Errored Seconds has exceeded the user-selected Errored Seconds threshold.
H2ES	HDSL Loop 2 Errored Second	The number of Loop 2's Errored Seconds has exceeded the user-selected Errored Seconds threshold.
G.703	Alarm	An alarm signal received from equipment connected to ELU-319 G.703 port; not generated by ELU-319.
MAL1	Margin Alarm (HDSL Loop 1)	The margin on HDSL Loop 1 dropped below the Margin Alarm Threshold (1 to 15). Setting the threshold to 0 (zero) inhibits the alarm.
MAL2	Margin Alarm (HDSL Loop 2)	The margin on HDSL Loop 2 dropped below the user Margin Alarm Threshold (1 to 15). Setting the threshold to 0 (zero) inhibits the alarm.
ACO	Alarm Cut Off	AI Alarm cut-off is in effect.
LAIS	Local Alarm Indicating Signal	Indicates an AIS (all 1's) pattern is being transmitted from the local G.703 output port.
RAIS	Remote Alarm Indicating Signal	Indicates an AIS (all 1's) pattern is being transmitted from the remote G.703 output port.
<b>LOOPBACKS</b>		
NREM	Network Remote Loopback	Loopback at ERU-412 (remote) towards network initiated from exchange, ERU-412 front panel pushbutton, or maintenance terminal. See Figure 4.
NLOC	Network Local Loopback	Loopback at ELU-319 (local) towards network initiated from exchange or by pressing both MODE and SEL pushbuttons on the ELU-319 front panel. See Figure 4.
CLOC	Customer Local Loopback	Loopback at ERU-412 (local) towards customer interface (CI) initiated from the ELU-319 front panel or maintenance terminal. See Figure 4.
CREM	Customer Remote Loopback	Loopback at ELU-319 (remote) towards customer interface (CI) initiated from the ELU-319 front panel or maintenance terminal. See Figure 4.

**TABLE 4. GLOSSARY OF HIGAIN TERMS**

<b>Term</b>	<b>Definition</b>
MARGINS	Indicates the excess signal to noise ratio, at either the ELU-319 or ERU-412, relative to a $10^{-7}$ Bit Error Rate. 1st value is current margin, 2nd value is minimum margin since (C)leared last, 3rd value is maximum value since cleared, and NA means Not Available (loops are not synchronized). The normal range of a typical margin is from 6 to 22 dB.
PULSE ATTENUATION	Indicates the attenuation of the 2B1Q pulse from the distant end. HiGain operates with pulse attenuations in excess of 30 dB. This value is related to the cable pair's loss at 260 kHz. The pulse attenuation is a more direct indication of the loop attenuation to the 2B1Q signal than the 260 kHz loss. The normal range of pulse attenuation is from 1 to 32 dB.
PPM	Indicates the relative offset (in parts per million) of the crystal oscillator in the ERU-412 from the ELU-319's crystal oscillator. Any value between -64 and +64 is adequate. Values outside this range indicate out-of- tolerance components or excessive temperature drift of critical components.
HDSL 24 Hour ES (Errored Seconds)	The number of 1-second intervals that contained at least 1 CRC error. This value is a running total of the last 24 hours.
HDSL 24 Hour UAS (Unavailable Seconds)	The number of seconds the HDSL loop was out of synchronization.
G.703 BPV Seconds (ES)	The number of seconds during which at least 1 bipolar violation was detected at the G.703 input.
G.703 UAS Count	The number of seconds during which the G.703 input signal was absent (125 or more consecutive zeroes).
ELU/Ver x.x-yyyy ERU/ver x.x-yyyy	"x.x" = the software version number of the ELU-319 or ERU-412. "yyyy" = the list number of the ELU-319 or ERU-412.

```

HI-GAIN ELU-319 (G.703)
MAINTENANCE TERMINAL MAIN MENU (ver 01.0L-0004)
CIRCUIT ID#:

A. VIEW SPAN STATUS
B. SET CLOCK
C. SYSTEM SETTINGS
D. LOOPBACK MODE: NONE
E. VIEW PERFORMANCE DATA
F. VIEW PERFORMANCE HISTORY
G. VIEW ALARM HISTORY
H. ENTER CIRCUIT ID #

```

Figure 7. ELU-319 Main Menu.

```

                                SPAN STATUS
                                (ELU/ver1.0-0004:ERU/ver1.0-0001)
TIME: 00:32:55
DATE: 03/10/95                                CIRCUIT ID#:

ALARMS: LAIS RAIS LLOS RLOS
LOOPBACK: OFF

                                ELU                                ERU
                                HDSL-1                                HDSL-2
                                cur/min/max                                cur/min/max
MARGIN:                                21/20/23                                21/20/23
PULSE ATTN:                                01                                01
PPM OFFSET:                                00                                00
24 HOUR ES:                                00001                                00000
24 HOUR UAS:                                00034                                00034

                                HDSL-1                                HDSL-2
                                cur/min/max                                cur/min/max
MARGIN:                                22/21/23                                21/20/22 dB
PULSE ATTN:                                02                                02 dB
PPM OFFSET:                                -08                                -08 ppm
24 HOUR ES:                                00002                                00002 seconds
24 HOUR UAS:                                00008                                00000 seconds

                                G.703 STATUS
                                ELU                                ERU
24 HOUR BPU Seconds:                                00000                                00002
24 HOUR UAS Count:                                01950                                01950

                                (E)xit (C)lear (U)pdate█

```

Figure 8. Span Status Display.

```

                                SYSTEM SETTINGS
TIME: 00:35:48
DATE: 03/10/95                                CIRCUIT ID#:

(P)OWER:                                ENABLE
ES ALARM TH(R)ES:                                NONE
LOOPBACK (T)IMEOUT:                                120
(A)LARM:                                DISABLE
MAR(G)IN ALM THRES:                                4

                                (E)xit
                                Enter the letter in parenthesis (X) to change any setting█

```

Figure 9. System Settings Menu.

```

                                SET CLOCK

TIME: 00:36:59
DATE: 03/10/95
CIRCUIT ID#:

Format: HH:MM
       MM/DD/YY

NEW TIME:

NEW DATE:

(U)PDATE REMOTE?█
    
```

Figure 10. Set Clock Menu.

```

Date: 03/10/95
CIRCUIT ID#:

                                PERFORMANCE DATA
                                ERRORED SECONDS/UNAVAILABLE SECONDS

                                G.703                HDSL-1                HDSL-2
                                ELU    ERU          ELU    ERU          ELU    ERU
20:45    000/000    000/000    000/000    000/000    000/000    000/000
21:00    000/000    000/000    000/000    000/000    000/000    000/000
21:15    000/000    000/000    000/000    000/000    000/000    000/000
21:30    000/000    000/000    000/000    000/000    000/000    000/000
21:45    000/000    000/000    000/000    000/000    000/000    000/000
22:00    000/000    000/000    000/000    000/000    000/000    000/000
22:15    000/000    000/000    000/000    000/000    000/000    000/000
22:30    000/000    000/000    000/000    000/000    000/000    000/000
22:45    000/000    000/000    000/000    000/000    000/000    000/000
23:00    000/000    000/000    000/000    000/000    000/000    000/000
23:15    000/000    000/000    000/000    000/000    000/000    000/000
23:30    000/000    000/000    000/000    000/000    000/000    000/000
23:45    000/000    000/000    000/000    000/000    000/000    000/000
00:00    000/000    000/000    000/000    000/000    000/000    000/000
00:15    000/872    002/872    001/034    002/008    000/034    002/000
00:30    000/900    000/900    000/000    000/000    000/000    000/000

                                (E)xit (P)revious (N)ext█
    
```

Figure 11. Performance Data Display.

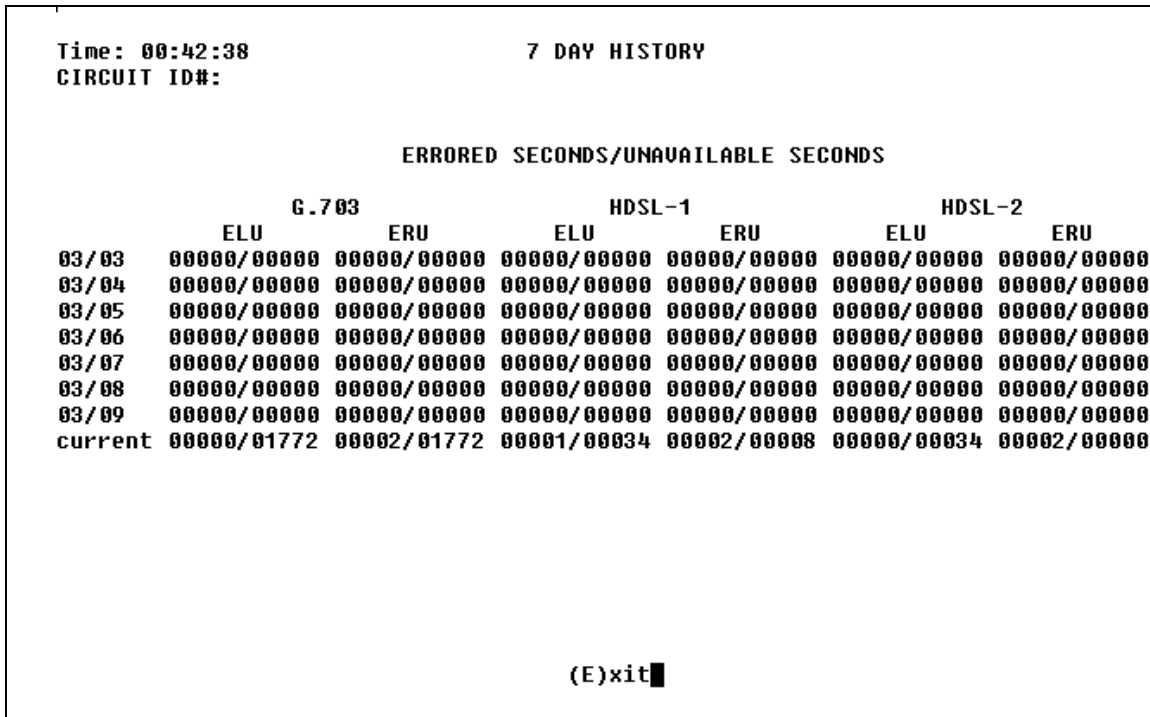

Figure 12. Performance Data History Display.

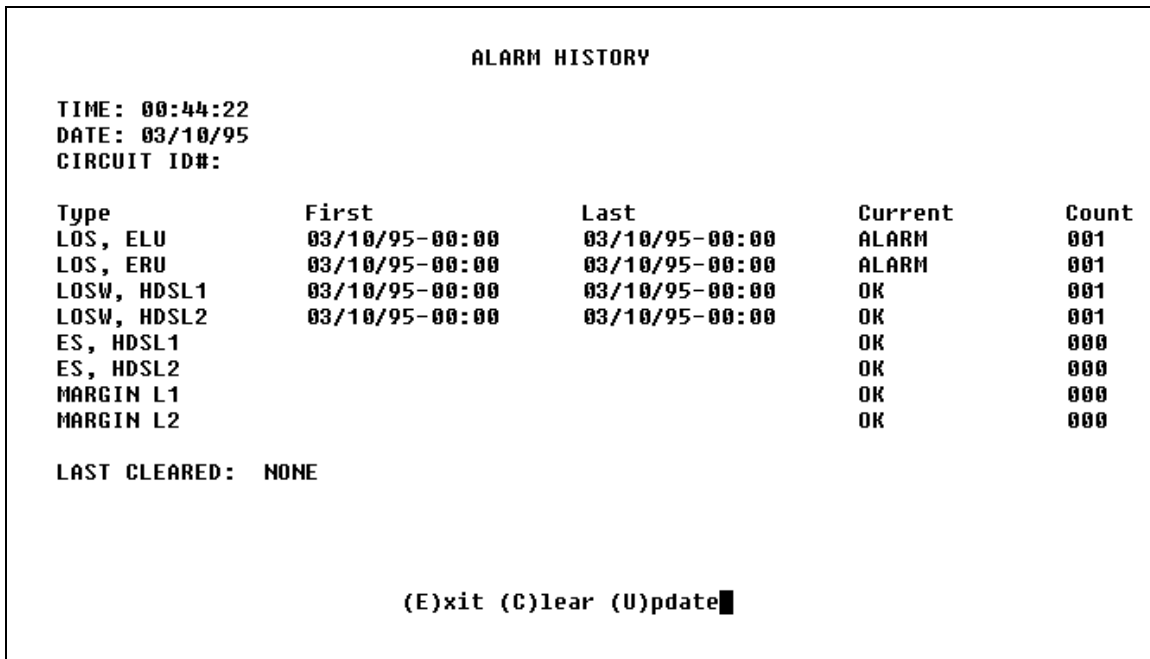

Figure 13. Alarm History Display.



```
                                LOOPBACK MENU

TIME: 00:45:32
DATE: 03/10/95
CIRCUIT ID#:

A. DISABLE LOOPBACKS
B. ELU LOOP TO NETWORK      (NLOC)
C. ERU LOOP TO NETWORK     (NREM)
G. ELU LOOP TO CUSTOMER   (CREM)
H. ERU LOOP TO CUSTOMER   (CLOC)
(E)xit
```

Figure 14. Loopback Menu.