

HiGain

TECHNICAL PRACTICE

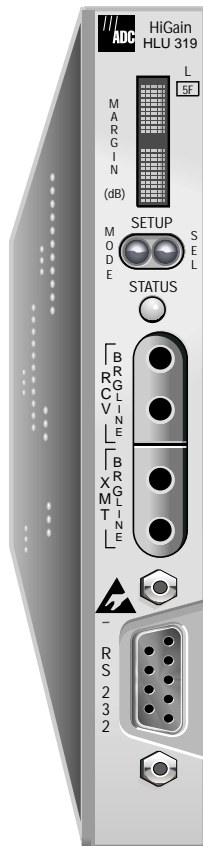

HLU-319 List 5F Line Unit
Part Number: 150-1140-56
CLEI Code: T1L4FXLB

Revision History of this Practice

To order copies of this document, use document catalog number LTPH-TP-1026-01.

Revision	Release Date	Revisions Made
01	January 9, 2001	Initial release

Copyright

January 9, 2001

© Copyright 2001 ADC DSL Systems, Inc. All rights reserved.

Trademark Information

ADC is a registered trademark of ADC Telecommunications, Inc.

HiGain is a registered trademark of PairGain Technologies, Inc. No right, license, or interest to such trademarks is granted hereunder, and you agree that no such right, license, or interest shall be asserted by you with respect to such trademark.

Other product names mentioned in this practice are used for identification purposes only and may be trademarks or registered trademarks of their respective companies.



Disclaimer of Liability

Information contained in this document is company private to ADC DSL Systems, Inc., and shall not be modified, used, copied, reproduced or disclosed in whole or in part without the written consent of ADC.

Contents herein are current as of the date of publication. ADC reserves the right to change the contents without prior notice. In no event shall ADC be liable for any damages resulting from loss of data, loss of use, or loss of profits, and ADC further disclaims any and all liability for indirect, incidental, special, consequential or other similar damages. This disclaimer of liability applies to all products, publications and services during and after the warranty period.

USING THIS TECHNICAL PRACTICE

The following conventions are used in this practice:

- Monospace type indicates screen text.
- Keys you press are indicated by small icons such as  or .
- Default settings are in **bold**.
- Three types of messages, identified by icons, appear in text.



Notes contain information about special circumstances.



Cautions indicate the possibility of equipment damage or personal injury.



The Electrostatic Discharge (ESD) symbol indicates that a device or assembly is susceptible to damage from electrostatic discharge.

For a list of abbreviations used in this document, refer to [“Appendix E - Abbreviations”](#) on page 63.

INSPECTING THE SHIPMENT

Upon receipt of the equipment:

- Unpack each container and inspect the contents for signs of damage. If the equipment has been damaged in transit, immediately report the extent of damage to the transportation company and to ADC DSL Systems, Inc. Order replacement equipment, if necessary.
- Check the packing list to ensure complete and accurate shipment of each listed item. If the shipment is short or irregular, contact ADC DSL Systems, Inc. as described in [“Returns”](#) on page 61. If you must store the equipment for a prolonged period, store the equipment in its original container.

TABLE OF CONTENTS

Overview	1
Features	1
Compatibility	2
Applications	2
HiGain Doubler Applications	2
Front Panel	3
Installation	7
Verification without a Downstream Device	8
Verification with a Downstream Device.....	8
Provisioning	9
Using the SEL and MODE Pushbuttons	9
Setting Options through SEL and MODE	9
Resetting to Factory Default Values.....	10
Displaying System Parameter Settings.....	10
Disabling an Alarm.....	10
Loopback Modes	10
Using a Maintenance Terminal	11
Connecting to a Maintenance Terminal.....	11
Maintenance Terminal Screens	11
Using the Maintenance Terminal Main Menu.....	12
Selecting a Maintenance Terminal Function	13
System Spans	13
Viewing Span Status Screens.....	14
Span Status Screen without Doublers.....	14
Span Status Screen for Doubler Applications	14
Provisioning Tasks	18
Set Clock Screen.....	18
System Settings Screens	19
Loopback Menu Screen	25
View Performance Data Screen.....	28
View Performance History Screen	30
View Alarm History Screen	31
View System Inventory Screen	33
View Troubleshooting Screen	35
Testing	39
Front-Panel System Alarms	39

Alarm Option for DLC Feed	40
Retiring System Alarms	40
Self Test	40
Loopback Operation	40
Generic Loopback Commands	41
Special Loopback Commands	42
Manual Loopback Session.....	43
Setting the Loopback Time-out Option	43
Activating Manual Loopback Mode	43
Loopback Test Procedures	44
General Troubleshooting Tips	44
GNLB Test Procedures	44
A1LB, A2LB, and A5LB Test Procedures	46
A3LB and A4LB Test Procedures	49
Appendix A - Specifications	50
HDSL Insertion Loss Guidelines.....	51
Power Consumption	51
Power Consumption without Doublers	51
Power Consumption with Doublers	52
Maximum Power Dissipation	54
Maximum Current Drain	54
Loop Attenuation.....	54
HLU-319 List 5F Card Connector.....	55
Network Management Control Bus	55
Fuse Alarm	56
System Alarm Relay Output	56
Craft Port	57
Appendix B - Functional Operation	58
Timing	58
Ground Fault Detect	58
Appendix C - Compatibility	59
DS1 Repeater Shelves and Related Equipment.....	59
HiGain Doubler Circuit Deployment	59
Appendix D - Service and Support	61
Technical Support.....	61
Returns.....	61
Appendix E - Abbreviations	63
Certification and Warranty	Inside Back Cover

LIST OF FIGURES

1. HLU-319 List 5F Front Panel.....	3
2. Installing the HLU-319 List 5F into a Shelf.....	7
3. Maintenance Terminal Main Menu	12
4. System Spans.....	13
5. Span Status Screen: No Doubler	14
6. Span Status Screen: Four Doublers (Span 5)	15
7. Set Clock Screen.....	18
8. System Settings Screen.....	19
9. Loopback Menu: No Doubler.....	26
10. Loopback Menu: Four Doublers	26
11. NLOC Loopback Mode Reported in the Maintenance Terminal Main Menu	27
12. Performance Data Screen: No Doubler	29
13. Performance Data Screen: Four Doublers (Span 5)	29
14. 31-Day Performance History Screen: No Doubler.....	30
15. 31-Day Performance History Screen: Four Doublers (Span 5).....	31
16. Alarm History Screen: No Doubler.....	32
17. Alarm History Screen: Four Doublers (Span 5).....	33
18. System Inventory Screen: No Doubler.....	34
19. System Inventory Screen: Four Doublers.....	35
20. Troubleshooting Screen for a Doubler Application	35
21. Troubleshooting Screen Describing Circuit Problem.....	36
22. Troubleshooting with Help.....	37
23. Troubleshooting with Margin Values.....	37
24. Troubleshooting with Insertion Loss Values.....	38
25. Loopback Summary.....	40
26. Loopback Modes	45
27. HLU-319 List 5F Card-Edge Connector	55
28. RS-232 Craft Port Pinouts	57
29. HLU-319 List 5F Block Diagram.....	58

LIST OF TABLES

1. Front-Panel Description	4
2. Front-Panel Display Messages.....	5
3. Navigational Keys on the Maintenance Terminal	11
4. Maintenance Terminal Screens.....	13
5. Span Status Fields and Descriptions	16
6. HDSL System Alarms	17
7. Loopback Messages	17
8. HLU-319 List 5F System Settings.....	20
9. Loopback Field Messages and Descriptions.....	25
10. Errored and Unavailable Seconds Definitions	28
11. Alarm History Fields and Descriptions	32
12. HDSL System Alarms	39
13. Summary of HiGain Loopback Codes and Activation Methods	41
14. Addressable Repeater Loopback Commands (A1LB, A2LB, A5LB).....	46
15. Addressable Repeater Loopback Commands (A3LB and A4LB).....	49
16. HDSL Loss Over Cables.....	51
17. HLU-319 Power Parameters—No Doubler	51
18. HLU-319 Power Parameters—Single Doubler (HDU-451 List 1 or 2)	52
19. HLU-319 Power Parameters—Single Doubler (HDU-439 or HDU-437 Lists 1 and 1B)	52
20. HLU-319 Power Parameters—Single Doubler (HDU-409 List 2).....	52
21. HLU-319 Power Parameters—Two Doublers (HDU-451 List 3, 4, 3B or 4B)	53
22. HLU-319 Power Parameters—Two Doublers (HDU-439 or HDU-437 Lists 1 and 1B).....	53
23. HLU-319 Power Parameters—Two Doublers (HDU-409 List 2)	53
24. HLU-319 Power Parameters—Three and Four Doublers (HDU-409 List 2).....	53
25. HDSL2 Cable Attenuation Chart.....	54
26. HiGain Doubler Deployment Matrix	60

OVERVIEW

The HiGain® Line Unit HLU-319 List 5F is the Central Office (CO) side of a repeaterless T1 transmission system. When used in conjunction with a HiGain Remote Unit (HRU), the system provides 1.544 Mbps transmission on two unconditioned copper pairs over the full Carrier Service Area (CSA) range. The CSA includes loops up to 12,000 feet of 24 AWG wire or 9,000 feet of 26 AWG wire, including bridged taps. This line unit can be used with HiGain Doubler Units (HDUs) to extend reach.



In contrast to the List 5, the List 5F has default option settings of UNFR and B8ZS for its framing and line code options, respectively. The List 5F is also compatible with the ground-reference sealing current circuit in Pulsecom's HDSL2 and 64 Subscriber Loop Carrier (SLC) Series 5 plugs provided the loops are reversed.

FEATURES

The HLU-319 line unit is the Central Office (CO) side of a T1 transmission system.

- HLU-319 transmission features
 - Five-span range with four doublers (60 kft, 24 AWG)
 - Four line-powered spans (three doublers and one remote)
 - Lightning and power cross-protection on HDSL interfaces
 - Full duplex 2B1Q HDSL transmission on two pairs at 784 kbps
 - Ultra-low wander (Stratum 1 compliant)
 - Grounded loop detection on High-bit-rate Digital Subscriber Line (HDSL)
- Front-panel provisioning features
 - Four-character status display
 - DS1 splitting and bridging access
 - Status Light Emitting Diode LED
 - RS-232 craft port for connection to a maintenance terminal
- HiGain HDSL maintenance screens for inventory, provisioning, and troubleshooting
 - HRU loopback screen
 - Payload (PL) or HiGain (HG) loopback source identification
 - Margin Alarm Threshold (MAL)
- Configuration options
 - Selectable DS1 pre-equalizer
 - Bipolar Violation Transparency (BPVT)
 - Bit Error Rate (BER) alarm
 - Loss of Signal/Alarm Indicator Signal (LOS/AIS) payload alarm
 - Remote Loss of Signal (RLOS) disable alarm
 - Selectable loopback activation codes

- Compatible with Span Terminating Shelf (STS) high-density shelves
- Reduced power consumption
- Low line-power option (-140 Vdc) for circuits with a single doubler
- Selectable Power Feed (PWRP) modes: Auto, High, and Low
- Network Management and Administration (NMA) interface



DS1 is used throughout this document to refer to either the remote unit's DS1 interface or the line unit's DSX-1 interface.

COMPATIBILITY

The HLU-319 is designed to mount in a STS high-density shelf. For a list of compatible shelves see “[Appendix C - Compatibility](#)” on page 59.

All generations of HiGain HLU-319 and HRU modules are compatible with each other. To take advantage of the enhanced features of newer HiGain doublers, refer to “[HiGain Doubler Circuit Deployment](#)” on page 59.

APPLICATIONS

HiGain systems provide a cost-effective, easy-to-deploy method for delivering T1 High Capacity Digital Service (HCDS) over metallic pairs.

- The service is deployed over two unconditioned, non-loaded copper pairs, yet it demonstrates a quality that is competitive with fiber optics.
- Conventional, in-line DS1 repeaters are not required.
- Cable pair conditioning, pair separation, and bridged tap removal are not required.

In general, HiGain systems:

- Operate with any number of other DS1, POTS, Digital Data Service (DDS) or other HiGain systems sharing the same cable binder group.
- Can be used with customers requiring DS1 service on a temporary or permanent basis.
- Provide a means of quickly deploying service in advance of fiber-optic transmission systems.

With a HiGain system, service can be provided within hours. Fiber-optic systems can be installed incrementally and cut over from the installed HiGain system when convenient to do so.

HiGain Doubler Applications

For applications without doublers, the HLU-319 is directly connected to the HRU by the two HDSL cable pairs. The HLU-319 List 5F is compatible with all HiGain HRUs.

For doubler applications, one to four doublers may be used in the HDSL loops between the HLU-319 and HRU.

- If the HRU is line-powered, the HLU-319 can power three doublers and the remote unit (HRU-402) for a total of four spans.
- If the HRU is locally powered, the HLU-319 can power up to four doublers for a total of five spans.



These extended ranges are only available when using the HDU-404, HDU-407 or HDU-409 micro-doublers with the HRU-402. Older doublers (HDU-451, HDU-439, and HDU-437) cannot be used in circuits with more than two doublers in any line or local power system. For compatibility guidelines on mixing newer doublers with older HRU and HLU-319 models, refer to “[HiGain Doubler Circuit Deployment](#)” on page 59.

For additional information about associated HiGain equipment, refer to the respective HiGain technical practice (see “[Appendix D - Service and Support](#)” on page 61).

FRONT PANEL

The HLU-319 List 5F front panel is shown in [Figure 1](#). The front-panel components are described in [Table 1](#) on page 4. For pinout diagrams of the HLU-319 card-edge connector and the craft port, refer to “[Appendix A - Specifications](#)” on page 50.

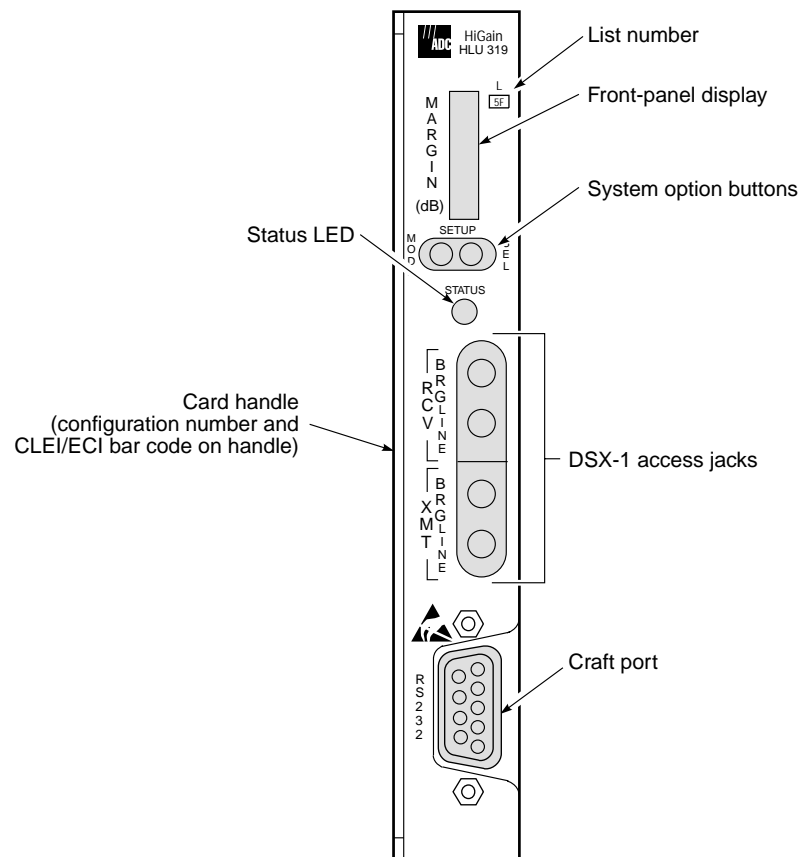

Figure 1. HLU-319 List 5F Front Panel

Table 1. Front-Panel Description

Front-Panel Feature	Function
Front-panel display	Displays four-character status, provisioning, and alarm system messages. The front-panel display illuminates when power is initially applied. To conserve power the display only remains on for 4 minutes. Use the MODE or SEL pushbuttons to reactivate the display and restart the 4-minute timer. Refer to Table 2 on page 5 for a listing of the four-character messages.
MODE and SEL system option pushbuttons	Permits the user options to be monitored and modified without the need of a maintenance terminal. Used to initiate all HiGain loopbacks and to display DSX-1 line parameters and line unit identity.
Status LED	The status LED can report the following conditions:
Green	Normal operation
Flashing green	HDSL acquisition
Red	Fuse Alarm
Flashing red	System alarm
Yellow	Self Test is in process or an HLU-319 Customer Remote Loopback (CREM) or a Network Local Loopback (NLOC) is in effect
Flashing yellow	HLU-319 is armed (ARM) to respond to Intelligent Repeater Loop (ILR) codes
DSX-1 access jacks	
LINE	Provides non-intrusive bridging jack access to (XMT) and from (RCV) the HDSL span at the DSX-1 interface. Allows the two DS1 payloads to be monitored.
BRG	Provides splitting jack access to (XMT) and from (RCV), the HDSL span at the DSX-1 interface. Breaks the XMT and RCV paths to permit test signal insertion and retrieval.
Craft (RS-232) port	Provides bidirectional communication between the unit and an external terminal to allow configuration and performance monitoring through the Maintenance Terminal screens.
CLEI and ECI bar code label	Provides the human-readable Common Language Equipment Identifier (CLEI) code number and the Equipment Catalog Item (ECI) bar code number.
List number	Identifies the version of the HLU-319.
Configuration Number	Identifies the version of the product. The configuration number is found on a small label attached to the front panel. It is the last two numbers (following the x) of a 13-character part number. For example: 150-1234-01-x01.

Table 2 lists the front-panel display messages. The four-character display reports the code of a pertinent alarm loopback or diagnostic message and, in some cases, is followed by a second four-character message that modifies the first message with a value or current configuration setting.

Table 2. *Front-Panel Display Messages*^(a)

Message	Full Name	Description
SYSTEM ALARM MESSAGES		
ACO	Alarm Cutoff	A system alarm has occurred, and has been retired to an ACO condition by pressing the SEL pushbutton on the HLU-319 front panel.
ALRM	Alarm Condition	A system alarm condition is in effect.
BER	Bit Error Rate	A system BER alarm is in effect.
LLOS	Local Loss of Signal	Indicates that no signal is detected at the DSX-1 input to the HLU-319. Causes a system alarm.
LOSW	Loss of Sync Word	Indicates that one of the HDSL loops has lost sync. Causes a system alarm.
MAL1 or MAL2	Margin Alarm Loop 1 or Loop 2	The margin on HDSL Loop 1 or Loop 2 has dropped below the threshold (1 to 15 dB) as set by the operator.
RLOS	Remote Loss of Signal	Indicates that no signal is detected at the DS1 input to the HRU. Causes a system alarm.
LOOPBACK MESSAGES		
CDU n ?	Customer Doubler n Loopback	DS1 signal from customer is looped back to the customer at CDU n , where n is the number of the doubler.
CLOC	Customer Local Loopback	DS1 signal from customer is looped back to the customer at the HRU.
CREM	Customer Remote Loopback	DS1 signal from customer is looped back to the customer at the HLU.
NDU n ?	Network Doubler n Loopback	DSX-1 signal is looped back to the network at the NDU n , where n is the number of the doubler.
NLOC	Network Local Loopback	DSX-1 signal is looped back to the network at the HLU-319.
NREM	Network Remote Loopback	DSX-1 signal is looped back to DSX-1 at the HRU.
SMJK	Remote SmartJack Loopback	DSX-1 signal is looped back to the network at the HRU SmartJack module.
DIAGNOSTIC MESSAGES		
1=xx or 2=yy	HDSL Loop Margins	Indicates the power of the received HDSL signal on each loop relative to noise. Any value of 06 dB or greater is adequate for reliable system operation.
ACQ1 or ACQ2	Acquisition 1 or 2	The multiplexers of the HLU-319 and the HRU or first doubler are trying to establish synchronization over Loop 1 or Loop 2 of Span 1.
AnL1 or AnL2	Acquisition n Loop 1 or Loop 2	The multiplexers of the two devices on Span (n) are trying to establish synchronization with each other on Loop 1 or Loop 2, where n is the number of the span.
ARM	HiGain System Armed	Armed to respond to Intelligent Line Repeater (ILR) loop codes.
BAD RT?	No response from HRU	The HLU does not receive any response from the HRU. Therefore, the integrity of the HRU or the two HDSL loops (they may be open) is questionable.
DS0	DS0 Blocked Channels	Indicates status of DS0 blocked channels. NONE indicates no channels are blocked. BLK indicates some channels are blocked.
FERR	Framing Bit Error	Framing bit error occurred at HLU-319 DSX-1 input.

Continued

Table 2. Front-Panel Display Messages^(a) (Continued)

Message	Full Name	Description
H1ES or H2ES	HDSL CRC Error Channel 1 or Channel 2	HDSL Loop 1 or Loop 2 Cyclical Redundancy Check (CRC) error.
<i>n</i> HDU	Number of Doublers	Indicates the number (<i>n</i>) of doublers in the circuit.
INSL, then <i>xx</i> DB	Maximum Insertion Loss	The maximum Insertion Loss (INSL) message appears followed by <i>xx</i> DB, where <i>xx</i> is the maximum insertion in dB of all spans and loops.
LBPV	Local Bipolar Violation	A bipolar violation has been received at the DSX-1 input to the HLU-319.
MNGD	Managed	The HLU-319 is under control of the HMU-319 network management unit. In this state, the front-panel craft port and pushbuttons are disabled.
PWRF GND	Power Feed Ground	One of the HDSL loops has been grounded.
PWRF ON	Power Feed On	Indicates that the HDSL loops are not grounded or shorted.
PWRF OFF	Power Feed Off	HDSL span power has been turned off by setting the PWFD option to DIS, or HDSL span power has been turned off by use of the A1LB, A2LB, A5LB Intelligent Office Repeater (IOR) power down code.
PWRF SHRT	Power Feed Short	Indicates a short between the two HDSL pairs. This same message can occur with an HRU that is drawing the correct amount of power over good cable pairs but cannot communicate with the HLU-319.
SELF TEST	Self Test	The HLU-319 is in a self-test mode. This occurs every power On/Off cycle.
SIG1 or SIG2	Signal 1 or Signal 2	The transceivers of the HLU-319 and HRU, or first doubler, are trying to establish contact with each other on Loop 1 or Loop 2 of Span 1.
<i>S_n</i> L1 or <i>S_n</i> L2	Signal <i>n</i> Loop 1 or Loop 2	The transceivers of the two devices on Span <i>n</i> are trying to establish contact with each other on Loop 1 or Loop 2, where <i>n</i> is the number of the span.
TLOS	Transmit Loss of Signal	DSX-1 signal is looped back to the DSX-1 interface at the HRU. HRU is in a logic loopback state caused by a loss of its DS1 input from the CI, if enabled at the HRU by its TLOS switch option.

SYSTEM INFORMATION MESSAGES

CODE <i>xxxx</i>	Line Code: AMI or B8ZS	The line code that HLU-319 List 5F is receiving at its DSX-1 interface, if the DS1 option is set to Auto. Otherwise, it mimics either of the other two DS1 line code settings, Alternate Mark Inversion (AMI) or Bipolar with 8-Zero Substitution (B8ZS). Displayed during System Settings review mode.
FRM <i>xxxx</i>	Frame: SF, ESF, UNFR, NONE	Defines the type of frame pattern being received from the DSX-1: SuperFrame (SF), Extended SuperFrame (ESF), Unframed (UNFR), or NONE. Displayed during System Settings review mode.
LIST <i>xxxx</i>	HLU-319 List Number	The list number (<i>xxxx</i>) appears during the System Settings review mode. Press the MODE pushbutton for 3 seconds to display the list number.
MARG <i>xx</i>	Margin	The current margin threshold setting, measured in dB, set by the user.
VER <i>xxxx</i>	HLU-319 Version Number	The software version number (<i>xxxx</i>) appears during the System Settings review mode. Press the MODE pushbutton for 3 seconds to display the software version.

(a) System information messages are displayed in scroll mode. To scroll through the messages, press the MODE pushbutton for 3 or more seconds.

INSTALLATION



Upon receipt of the equipment, inspect the contents for signs of damage. If the equipment has been damaged in transit, immediately report the extent of damage to the transportation company and to ADC DSL Systems, Inc.

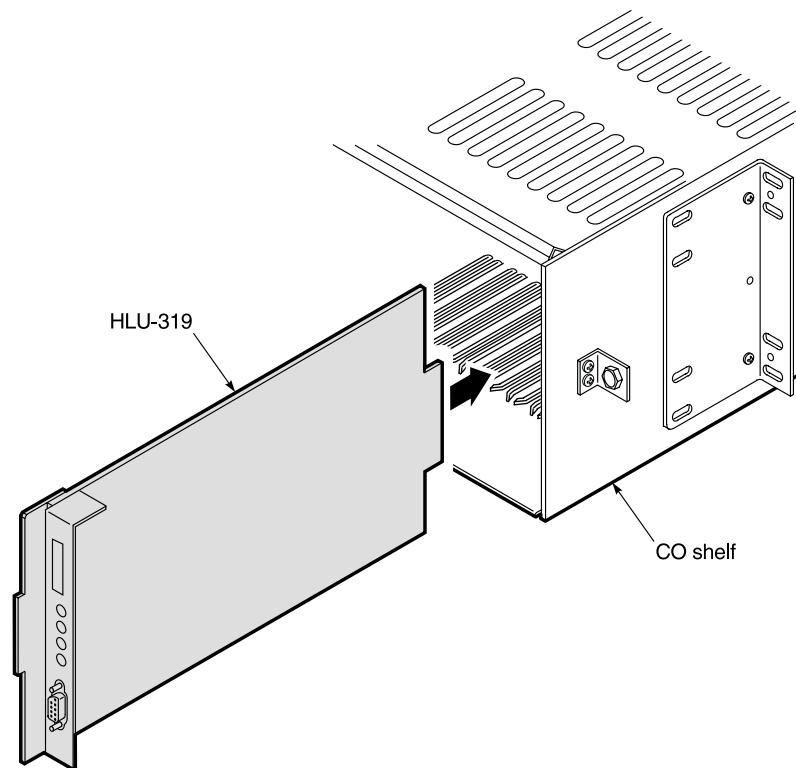

Figure 2. Installing the HLU-319 List 5F into a Shelf



When installing an HLU-319 in a chassis, be sure to wear an antistatic wrist strap. Avoid touching components on the circuit board.



To comply with the intrabuilding wiring requirements of GR-1089 CORE, Section 4.5.9, the shields of the ABAM-type cables that connect the HLU-319 DSX-1 output ports to the cross-connect panel must be grounded at both ends.

- 1 Slide the HLU-319 into the card guides for the desired slot, then push the unit in until it touches the backplane card-edge connector (Figure 2).
- 2 Place your thumbs on the HLU-319 front panel and push the unit into the card-edge connector until it is entirely within the card guides. This indicates that the card is properly seated.

Once- the HLU-319 is installed, verify that it is operating properly. To do this, you need to monitor the following:

- Status LED
- Status messages reported by the front-panel display (see [Table 2 on page 5](#))

VERIFICATION WITHOUT A DOWNSTREAM DEVICE

If a downstream device is not installed:

- 1 Verify that the HLU-319 powers up. (The front-panel display illuminates and reports four-character status messages. See [Table 2 on page 5](#) for a list of messages.)
- 2 Verify that the HLU-319 attempts to communicate with downstream devices (status LED flashes red). Even if a downstream device is not present, the following events should occur:
 - a The front-panel display reports four-character status messages.
 - b The HLU-319 again attempts communication until a downstream device is detected.

VERIFICATION WITH A DOWNSTREAM DEVICE

If a downstream device is installed:

- 1 Verify that the HLU-319 powers up. (The front-panel display illuminates and reports status messages.)
- 2 Verify that the HLU-319 attempts to communicate with downstream devices (status LED flashes green). One of the following occurs:
 - If downstream devices are successfully identified and the HDSL loops synchronize, the HLU-319 status LED lights a steady green. The HLU-319 reports normal margin messages on the front-panel display.
 - If downstream devices are not successfully identified, the HLU-319 reports four-character status messages and enters self-test mode. The HLU-319 successively:
 - a enters self-test mode
 - b completes self-test mode
 - c attempts communication again
 - d reports four-character status messages.

The HLU-319 repeats this cycle until a downstream device is detected.

- 3 If there is more than one span, verify that each subsequent span synchronizes normally by monitoring the front-panel display messages.
- 4 If a remote unit is installed, verify that the last span synchronizes normally. The HLU-319 status LED should light a steady green, and the front-panel should report normal margin messages.
- 5 Verify that valid DS1 signals are being applied to the HLU-319 and the HRU.
 - If no DS1 signal is being applied to either the HLU-319 or the HRU inputs, then the appropriate DS1 alarms (LLOS or RLOS) display on the front-panel and the status LED flashes red.
 - If valid DS1 signals are being supplied to the HLU-319 and HRU, then DS1 alarm indications should be absent and the status LED should be a steady green.

PROVISIONING

This is a reference section for HLU-319 provisioning. There are two methods for provisioning the HLU-319 List 5F:

- Use the MODE and SEL pushbuttons on the front panel of the HLU-319 to:
 - Set system options
 - Reset the HLU-319 to its factory default settings for system options
 - Display system option settings (scroll mode)
- Use a maintenance terminal (ASCII terminal or a PC running terminal emulation software) connected to the HLU-319 craft port to access the Maintenance Terminal Main Menu (Figure 3 on page 12). This gives you full access to all HLU-319 status, history, inventory, and provisioning screens.



Dip switch or jumper settings are not required to provision the HLU-319 as it contains a non-volatile RAM (NVRAM) that stores the system option settings. System option settings are retained if shelf power is lost or the HLU-319 is unplugged.

USING THE SEL AND MODE PUSHBUTTONS

Setting Options through SEL and MODE

To provision the HLU-319 List 5F through the MODE and SEL pushbuttons on the front panel:

- 1 Press the MODE pushbutton for 1 second and then release it. The front-panel display alternately shows the first system parameter and its current setting.
- 2 Press the SEL pushbutton to step the display through all possible settings (one at a time) of the selected parameter.
- 3 After the desired setting has been selected, press the MODE pushbutton. This updates the current displayed parameter to the selected setting, and then advances to the next configurable parameter. After the last parameter has been selected, a CONF NO message appears on the front-panel display.
- 4 Do one of the following:
 - To cancel the session without saving the requested parameter changes, press the MODE pushbutton or do nothing. (After 30 seconds, the display returns to its normal mode without saving the new changes.)
 - To accept the requested parameter changes, press the SEL pushbutton. (A CONF YES message displays, and the display returns to its normal mode after saving the new changes.)

Resetting to Factory Default Values

All user options (Table 8 on page 20) can be set to the factory default values using the MODE and SEL pushbuttons. To set the user options to their default values:

- 1 Press the SEL pushbutton for 6 seconds until the following message appears:

DFLT NO

- 2 Press the SEL pushbutton while the DFLT NO message is displayed.

The message changes to DFLT YES indicating the factory default values are now in effect and the display returns to the normal mode.

To terminate the DFLT mode without setting the factory default values, do one of the following:

- Press the MODE pushbutton to return to the normal display mode
- Wait 30 seconds for the unit to return to the normal display mode.

Displaying System Parameter Settings

To scroll through the current settings of all system parameters, press the MODE pushbutton for 3 or more seconds. The HLU-319 displays the following parameters:

- Software version number
- List number
- Type of frame pattern being received from the DSX-1
- Line code of the signal being received from the DSX-1 (see note below)
- HDSL power level setting
- All user-configured parameter settings



The line code parameter is the actual DSX-1 line code being received by the HLU-319 if the DSX-1 code pattern is set to AUTO. Otherwise, the line code parameter mimics either of the other two line code settings, Alternate Mark Inversion (AMI) or Bipolar with 8-Zero Substitution (B8ZS).

Disabling an Alarm

If the system is in a Minor alarm state, the alarm relay can be disengaged by pressing the SEL pushbutton. This executes an Alarm Cutoff (ACO) and returns the HLU to its non-alarm state. For more information about alarms, see “Front-Panel System Alarms” on page 39.

Loopback Modes

See “Loopback Operation” on page 40 for instructions on using the MODE and SEL pushbuttons to activate loopbacks.

USING A MAINTENANCE TERMINAL

Connecting to a Maintenance Terminal

The craft port on the front panel allows you to connect the HLU-319 to a maintenance terminal (ASCII terminal or PC running a terminal emulation program). Once connected to a maintenance terminal, you can access the maintenance, provisioning, and performance screens.

To connect to a maintenance terminal:

- 1 Connect a standard 9-pin terminal cable to the RS-232 craft port (Figure 1 on page 3) on the HLU-319 front panel.
- 2 Connect the other end of the cable to the serial port on the maintenance terminal.
- 3 Start a terminal emulation program such as Procomm (emulating a VT100 terminal).
- 4 Configure the maintenance terminal to the following communication settings:
 - 1200 to 9600 baud (9600 baud is recommended)
 - No parity
 - 8 data bits
 - 1 stop bit
 - Hardware flow control to OFF
- 5 Press the **SPACEBAR** several times to initiate the autobaud connection and to initialize the Maintenance Terminal screens.

Maintenance Terminal Screens

The following sections describe how to use the Maintenance Terminal screens to view, provision, and diagnose an HLU-319 List 5F system. Table 3 summarizes the navigational keys used to navigate the Maintenance Terminal screens.

Table 3. Navigational Keys on the Maintenance Terminal

Key	Function
A	Automatically updates the screen data
U	Updates screen data
C	Clears screen data
S	Selects the next Span Status screen (for doubler applications)
1 , 2 , 3 , 4 , or 5	Selects a specific Span Status screen (for doubler applications)
P	Selects the previous page of screen data
N	Selects the next page of screen data
E	Exits the current screen
L	Selects the Loopback Menu from the Troubleshooting screen
B	Returns to the main Troubleshooting screen from the Troubleshooting (H)elp, (M)argin Values, or (I)nsertion Loss screens
T	Returns to main Troubleshooting from the Loopback Menu.
H	Selects the Troubleshooting with Help screen which provides an explanation of the circuit problem.
D	Updates the defaults.



Most VT100 emulation programs support a print screen option. For Windows-based programs, such as Procomm or HyperTerminal, do the following:

- 1 Highlight the screen that you wish to print.
- 2 Click File, then Print.
- 3 In the Print dialog box, choose Selection as the Print Range.
- 4 Click OK to print.

For printing procedures for other programs, contact the appropriate vendor.

Using the Maintenance Terminal Main Menu

Figure 3 shows the Maintenance Terminal Main Menu from which you can access system administration screens. The function of each screen selection is listed in Table 4. To access a screen, type the letter shown next to the menu item.

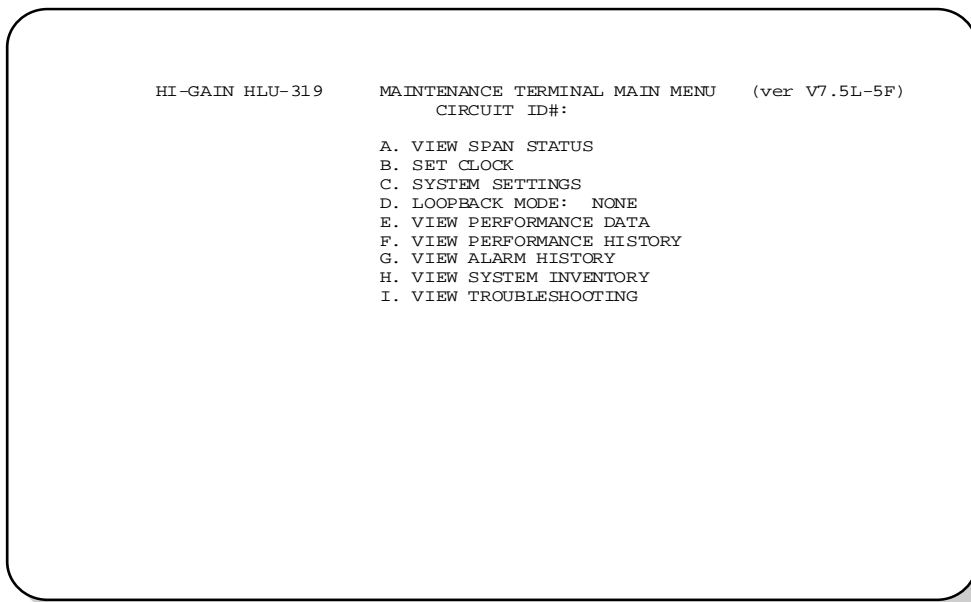

Figure 3. Maintenance Terminal Main Menu

Table 4. Maintenance Terminal Screens

Press Key	To View Screen	Screen Description	See page:
A	View Span Status	Provides access to subscreens that allow you to monitor the HDSL and DS1 line status between the HLU and the HRU.	14
B	Set Clock	Allows you to set both the time and the date parameters at the HLU and to update the same settings at the HRU.	18
C	System Settings	Allows you to set all user options.	19
D	Loopback Mode: NONE	Provides access to a subscreen that allows you to enable and disable loopbacks at both the network and customer side.	25
E	View Performance Data	Provides access to subscreens that allow you to view the Errored Seconds (ES) and Unavailable Seconds (UAS) for each span between the HLU and the HRU in 15-minute intervals over a 4-hour time period per screen for a total of 24 hours (6 screens).	28
F	View Performance History	Provides access to subscreens that allow you to view the ES and UAS for each span between the HLU and the HRU in 24-hour intervals over a 31-day period.	30
G	View Alarm History	Provides access to subscreens that allow you to view alarm conditions for each span between the HLU and the HRU.	31
H	View System Inventory	Allows you to enter a unique circuit ID (up to 24 alphanumeric characters) and view list number, software version, and CLEI code.	33
I	View Troubleshooting	Provides a graphical analysis of the circuit and identifies problem areas.	35

Selecting a Maintenance Terminal Function

To perform a function within the Maintenance Terminal screens, you can:

- Press the key indicated to the left of the selection.
- Press the letter in parenthesis for the parameter to be changed.

System Spans

As shown in [Figure 4](#), the HLU-319 can support up to four doublers with five HDSL spans. The Span Status, Performance Data, and Performance History may display as many as five screens to depict an HLU-319 List 5F system.

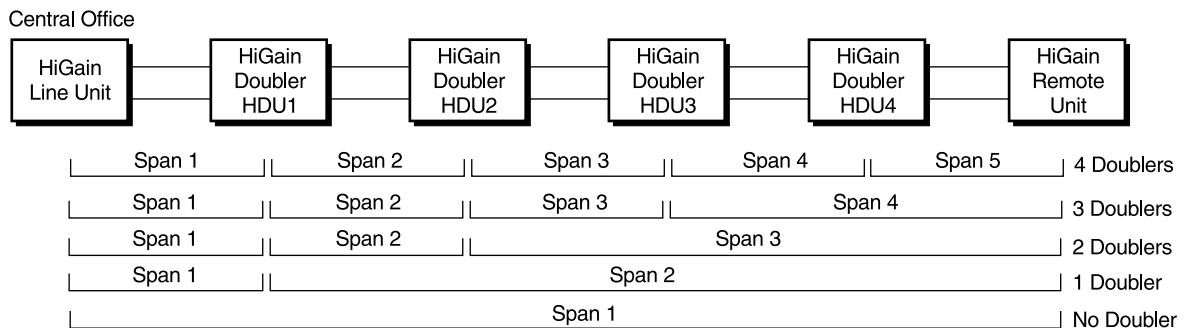

Figure 4. System Spans

VIEWING SPAN STATUS SCREENS

The View Span Status option allows you to view up to five system status screens that provide information about the HDSL Loop 1, HDSL Loop 2, and the DS1. For doubler applications, the available Span Status screens depend on whether the system includes one, two, three, or four doublers.

Press **A** from the Maintenance Terminal Main Menu to open the Span Status screen (Figure 5 on page 14). If no doubler (HDU) is present, the screen reports span status for the subscriber lines between the HLU-319 and the HRU.

If there are additional doublers, the Span Status screen reports status on each span. Figure 6 on page 15 shows status between HDU4 and the HRU in a system with four doublers. Refer to Table 5 on page 16 for an explanation of the Span Status fields.

From each Span Status screen you can:

- Press **C** to clear the cur (current), min (minimum) and max (maximum) numeric counts. This also clears the Performance History and Performance Data screens.
- Press **A** to automatically update status screens. (Press **A** again to turn off auto update.)
- Press **U** to update cur (current) values.
- Press **S** to view the next available span (for doubler applications).
- Press **E** to exit and return to the previous screen.
- Press **1**, **2**, **3**, **4**, or **5** to select a specific span (for doubler applications).

Span Status Screen without Doublers

```

                                SPAN STATUS
TIME: 01:19:50
DATE: 11/15/00
ALARMS: NONE
LOOPBACK: OFF
POWER LEVEL: HIGH
                                CIRCUIT ID#:

                                HLU                                HRU
                                HDSL-1  HDSL-2  HDSL-1  HDSL-2
                                cur/min/max cur/min/max cur/min/max cur/min/max
MARGIN:          18/18/19    18/17/18    18/14/18    19/17/19 dB
PULSE ATTN:      27          27          27          27 dB
INS LOSS:        33          33          33          33 dB
24 HOUR ES:      00000      00000      00000      00000 seconds
24 HOUR UAS:     00000      00000      00000      00000 seconds

                                DS1 STATUS
                                HLU                                HRU
24 HOUR ES Count: 00000      00000
24 HOUR UAS Count: 00000      00000
Frame type:       ESF          ESF
Code type:        B8ZS         B8ZS

AUTOUPDATE ON          (E)xit (C)lear (A)uto(U)pdate

```

Figure 5. Span Status Screen: No Doubler

Span Status Screen for Doubler Applications

If doublers have been added, span status is reported on the Span Status screen. Span Status can have up to five screens, depending on the number of HDUs.

```

                                SPAN 5 STATUS
TIME: 01:17:45
DATE: 11/15/00
ALARMS: NONE
LOOPBACK: OFF
POWER LEVEL: HIGH
                                CIRCUIT ID#:

                                HDU4
                                HDSL-1   HDSL-2   HDSL-1   HDSL-2
                                cur/min/max cur/min/max cur/min/max cur/min/max
MARGIN:          14/13/16   16/15/17   18/17/18   18/06/19 dB
PULSE ATTN:      29        29         29         29 dB
INS LOSS:        36        36         36         36 dB
24 HOUR ES:      00021     00017     00050     00051 seconds
24 HOUR UAS:     00139     00119     00079     00069 seconds

                                DS1 STATUS
                                HLU         HRU
24 HOUR ES Count: 00001         00073
24 HOUR UAS Count: 00000         00052
Frame type:       ESF         ESF
Code type:        B8ZS        B8ZS

AUTOUPDATE ON      (E)xit (C)lear (A)uto(U)pdate (S)pan(1)(2)(3)(4)(5)

```

Figure 6. Span Status Screen: Four Doublers (Span 5)

Table 5 lists the Span Status fields and descriptions.

Table 5. Span Status Fields and Descriptions

Span Status Field	Description
Time	Time of day when Span Status was checked.
Date	Date when Span Status was checked.
Circuit ID#	Shows the user-defined circuit ID.
Alarms	Presence or absence of alarm conditions. See Table 12 on page 39 .
Loopback	Indicates Off condition or identifies specific active loopback. See Table 13 on page 41 .
Power Level	Indicates the HDSL line voltage in its Low (-140 Vdc) or High (± 112 Vdc) state.
Margin	Indicates the excess signal to noise ratio at all HDSL ports, relative to a 10^{-7} Bit Error Rate. <ul style="list-style-type: none"> • First value is current margin. • Second value is minimum margin since last cleared. • Third value is maximum margin since last cleared. • N/A means that the margin is not available. <p>The minimum and maximum margins are cleared and updated every time the Span Status screen is cleared and every time the system clock passes 12:00 AM midnight.</p>
Pulse ATTN	Indicates the attenuation of the 2B1Q pulse from the distant end. The value is related to the 196 kHz loss of the cable pair. The pulse attenuation is a more direct indication of the loop attenuation to the 2B1Q signal than is the 196 kHz loss. The normal HiGain ATTN operation range is from 0 to 28 dB.
INS Loss	Indicates the approximate insertion loss of the loops at the HDSL line rate of 196 kHz. It is generated by multiplying the pulse attenuation by 1.25. Normal range is 0 dB to 35 dB.
24-Hour ES	The number of one second intervals that contained at least one CRC error. This value is a running total of the last 24 Hours.
24-Hour UAS	The number of seconds the HDSL loop was out-of-sync.
24-Hour ES Count	The number of seconds in which at least one error was detected on the DS1 input over a 24-hour period. Errors included are: DS1 Frame errors; and UAS, BPV, and ESF CRC errors.
24-Hour UAS Count	The number of seconds during which the DS1 input signal was absent (175 ± 75 consecutive zeroes) over a 24-hour period.
Frame type	Type of DS1 framing used on the input stream (SF or ESF).
Code type	Type of DS1 line coding used (AMI, B8ZS, AMI: ZBTSI, or B8ZS: ZBTSI). The latter two indicate the code type that is being received when HiGain line is set to ZBTS1 mode. When set to AMI or B8ZS, the HLU-319 displays the selected code rather than the code type that is actually being received.



The Span Status screens shown on the previous page display a four-character code under the Alarms entry. These codes are described in [Table 6 on page 17](#).

The following codes are reported with a RCV or XMT prefix that indicates the signal is being transmitted or received: LLOS, RLOS, LAIS, or RAIS.

RCV (xxxx) - Signal received (xxxx) at the DS1 input to either the HLU-319 or HRU.

XMT (xxxx) - Signal transmitted (xxxx) at the DS1 output of either the HLU-319 or HRU.

Table 6 describes the alarm messages displayed on the Span Status screens.

Table 6. HDSL System Alarms

Message	Name	Description
BER	Bit Error Rate	The Total System Error Count (TSEC) has exceeded the user-selected threshold.
CHREV-SP n	Channels reversed	The Loop 1 and Loop 2 HDSL pairs are reversed at Span (n). Loop 1 is specified to carry the (-) simplex DC voltage, and Loop 2 is specified to carry the (+) simplex DC voltage. SP n indicates that the first occurrence of a reversed span is on Span (n), where n is the number of the span.
LOSW	Loss of Sync Word	One of the HDSL loops has lost synchronization.
LLOS	Local Loss of Signal	No signal from HLU-319 local DSX-1 input.
MAL1 or MAL2	Margin Alarm 1 or Margin Alarm 2	The margin on the HDSL Loop 1 or Loop 2 has dropped below the threshold (1 to 15 dB) set by the user. Setting the threshold to zero inhibits the margin alarm.
NONE	No Alarm	No alarm is indicated.
RAIS or LAIS	Remote (or Local) Alarm Indicating Signal	Indicates an AIS pattern of all ones is being transmitted from the remote (or local) DS1 output port.
RLOS	Remote Loss of Signal	Indicates that no signal is detected at the DS1 input to the HRU.

Table 7 lists loopback messages displayed on the Span Status screens. For information about loopback codes, see “GNLB Test Procedures” on page 44.

Table 7. Loopback Messages

Message	Full Name	Description
ARM	Armed	The HiGain system has detected the Intelligent Repeater (IR) loopback arming code (2-in-5).
CDU n	Customer Doubler n Loopback	Loopback at Doubler (n) toward Customer Installation (CI) initiated by an ILR code, the MODE and SEL pushbuttons on HLU-319 front panel, or by the maintenance terminal.
CLOC	Customer Local Loopback	Loopback at HRU (local) toward CI initiated from Customer Premises Equipment (CPE) by the ILR code, the MODE and SEL pushbuttons on the HLU-319 front panel, or by the maintenance terminal.
CREM	Customer Remote Loopback	Loopback at HLU-319 (remote) toward customer initiated by Intelligent Office Repeater (IOR) code, the MODE and SEL pushbuttons on the HLU-319 front panel, or by the maintenance terminal.
(HG)	HiGain	The loopback was initiated from a HiGain front panel or by a HiGain maintenance terminal loopback command.
NDU n	Network Doubler n Loopback	Loopback at Doubler (n) toward network initiated by ILR code, by the MODE and SEL pushbuttons on the HLU-319 front panel, or by the maintenance terminal.
NLOC	Network Local Loopback	Loopback HLU-319 toward network initiated from CO by IOR code, the MODE and SEL pushbuttons on the HLU-319 front panel, or by the maintenance terminal.
NREM	Network Remote Loopback	Loopback from HRU toward network initiated from CO (network) by ILR code, the MODE and SEL pushbuttons on the HLU-319 front panel, the HRU manual loopback pushbutton, or by the maintenance terminal.
OFF	Off	No active loopback mode.
(PL)	Pay Load	The loopback was initiated by a command that was embedded in the DS1 data path.
SMJK	SmartJack Loopback	Loopback at HRU toward network initiated by (2-in-5) inband loopback code or out-of-band ESF data link code.
TLOS	Transmit Loss of Signal Loopback	HRU is in a logic loopback state caused by a loss of its DS1 input from the CI (if enabled at the HRU through its TLOS switch option).

PROVISIONING TASKS

After the HLU-319 is successfully installed, perform these basic provisioning tasks.

- 1 Set the time and date (see “Set Clock Screen” on page 18).
- 2 Set the circuit IDs (see “View System Inventory Screen” on page 33).
- 3 Clear the Span Status, Performance Data, and Performance History screens. This can be accomplished by pressing **C** (clear) at the Span Status screen (see “Viewing Span Status Screens” on page 14). The View Span Status option allows you to view up to five system status screens that provide information about the HDSL Loop 1, HDSL Loop 2, and the DS1. For doubler applications, the available Span Status screens depend on whether the system includes one, two, three or four doublers.
- 4 Clear the Alarm History screens (see “View Alarm History Screen” on page 31).

Set Clock Screen

Press **B** at the Maintenance Terminal Main Menu to open the Set Clock screen (Figure 7).

```

SET CLOCK

TIME: 00:58:58
DATE: 11/15/00
CIRCUIT ID#:

Format: HH:MM
        MM/DD/YY

NEW TIME: 10:10
NEW DATE: 07/16/00
(U)PDATE REMOTE?
  
```

Figure 7. Set Clock Screen



All time information is lost when power is removed. The last date, however, is retained in NVRAM and reappears when power is restored.

Set Time

The cursor defaults to the New Time field. To set the system time, type the hour and minute in the 24-hour format of **hh:mm:ss** (setting the seconds is optional), then press **ENTER**. The New Date field appears.

Set Date

To set the system date, type the month, day and year in a **mm/dd/yy** format, then press **ENTER**. The Update Remote field appears.



When editing entries in the Set Clock screen and when using the Terminal emulation program in Windows 3.1, pressing the **BACKSPACE** key deletes two characters instead of just one.

Update the HRU Time and Date

The remote unit time and date are set by using this option. Do one of the following:

- Press **U** to update the HRU to the same time and date set for the HLU-319.
- Press **ENTER**. (The date and time are not updated.)

System Settings Screens

The options set from the System Settings screen are the same as the options set through the HLU-319's MODE and SEL pushbuttons on the front panel. The exceptions are Margin Alarm Threshold and DS0 Blocking, which can only be set at this screen. Refer to [Table 8 on page 20](#) for a listing of system setting options.

Press **C** at the Maintenance Terminal Main Menu to open the System Settings screen ([Figure 8](#)).

```

                                SYSTEM SETTINGS

TIME: 01:01:48
DATE: 11/15/00
A. EQUALIZATION.....: 0
B. SMART-JACK LPBK.: ENABLED
C. SPECIAL LPBK.....: GNLB
F. POWER.....: AUTO
G. ZBTSI.....: OFF
H. BER ALARM THRESH: NONE
I. LOOPBACK TIMEOUT: 60
J. ALARM.....: DISABLED
K. DS1 LINE CODE...: B8ZS
L. FRAMING.....: UNFR
M. AIS ON HDSL LOSW: 2 LOOPS
N. AIS ON SMJK/NREM: ENABLED

                                CIRCUIT ID#:
P. MARGIN ALARM THRESH: 4
Q. RLOS(DS1 LOS) ALARM: ENABLED
R. ALARM PATTERN.....: AIS
S. REMOTE PROVISION...: ENABLED
T. BPVT.....: DISABLED

                                O. DS0 BLOCKING: xx = Blocked Channels
01 02 03 04 05 06 07 08 09 10 11 12 13 14 15 16 17 18 19 20 21 22 23 24

                                (D)efaults (E)xit
Enter the option letter to change setting

```

Figure 8. System Settings Screen

You have the following options at the Systems Settings screen:

- Press the desired option letter to change that setting.
- Press **D** to set all user options to the factory default values. Press **E** to exit. If changes were made, the **C** (confirm) message displays in the lower left-hand corner of the screen. Press **C** to confirm the changes or press any other key to ignore changes.
- Press **E** to exit and return to the main menu.

Table 8 describes the System Settings options and lists the corresponding front-panel display codes. Factory default parameters appear in bold type.

Table 8. HLU-319 List 5F System Settings

System Settings Screen Options	Front-Panel Display Code	Parameter	Description
Equalization	EQL	0	Sets the Equalizer to DSX-1 for 0 to 132 feet.
		133	Sets the Equalizer to DSX-1 for 133 to 265 feet.
		266	Sets the Equalizer to DSX-1 for 266 to 398 feet.
		399	Sets the Equalizer to DSX-1 for 399 to 532 feet.
		533	Sets the Equalizer to DSX-1 for 533 to 655 feet.
Smart-Jack LPBK	LPBK	DIS	Configures the HiGain system to ignore all inband SmartJack loopback commands.
		ENA	Enables the HiGain system to recognize all inband SmartJack loopback commands.
Special LPBK	SPLB	GNLB	Configures the HiGain system to respond to the generic (3/4-in-7) inband loopback codes.
		A1LB and A2LB	Configures the HiGain system to respond to the inband loopback codes of the Teltrend addressable repeater.
		A3LB	Configures the HiGain system to respond to the inband loopback codes of the Wescom addressable repeater.
		A4LB	Configures the HiGain system to respond to the inband loopback codes of the Wescom Mod 1 addressable repeater.
		A5LB	Configures the HiGain system to respond to the inband loopback codes of the Teltrend Mod 1 addressable repeater.
Power See "HDSL Line Voltage Options" on page 24.	PWRF	DIS	Disables powering to the HDSL pair.
		LOW	Keeps the HDSL line voltage at -140 Vdc maximum for all applications.
		AUTO	Allows the HDSL line voltage to automatically switch between -140 Vdc maximum for non-doubler applications and ± 112 Vdc for doubler applications.
		HIGH	Forces the HDSL line voltage to ± 112 Vdc for all applications.
ZBTSI	ZBTS	ON	Tells the HiGain system that the ESF frame is operating in its Zero-Byte Timeslot Interchange (ZBTSI) mode.
		OFF	Tells the HiGain system that the ESF frame is operating in its normal non-ZBTSI mode.
BER Alarm Thresh See "BER Alarm Thresh Option" on page 22.	BERT	1E-6	Activates (closes) the system alarm relay contacts on pins 20 and 21 of the card-edge connector and flashes the red Status LED when the BER exceeds 10^{-6} .
		1E-7	Activates (closes) the system alarm relay contacts on pins 20 and 21 of the card-edge connector and flashes the red Status LED when $10^{-6} > \text{BER} > 10^{-7}$.
		NONE	Prevents generation of a system alarm due to BER.
Loopback Timeout	LBTO	NONE	Disables automatic time-out cancellation of all loopbacks.
		20	Sets automatic cancellation of all loopbacks to 20 minutes after initiation.
		60	Sets automatic cancellation of all loopbacks to 60 minutes after initiation.
		120	Sets automatic cancellation of all loopbacks to 120 minutes after initiation.
Alarm	ALM	DIS	Opens the system alarm relay contacts, if closed, and disables activation of the system alarm relay when a system alarm condition occurs.
		ENA	Enables activation of the system alarm relay when a system alarm condition occurs.

Continued

Table 8. HLU-319 List 5F System Settings (Continued)

System Settings Screen Options	Front-Panel Display Code	Parameter	Description
DS1 Line Code See "DS1 Line Code Option" on page 23.	DS1	AUTO	The HLU-319 and HRU monitor the incoming DS1 bit streams for the B8ZS line code. If the HRU detects this code, the HLU-319 enters B8ZS output mode. The HLU-319 reverts back to AMI output mode if no B8ZS codes are received at the HRU input for 5 seconds. Similarly, when the HLU-319 detects the B8ZS code, the HRU enters the B8ZS mode and returns to AMI mode if no B8ZS code is received at the HLU-319 input for 5 seconds.
		B8ZS	Places both the HLU-319 and HRU into their B8ZS modes.
		AMI	Places both the HLU-319 and HRU into their AMI modes.
Framing	FRMG	AUTO	Configures the HiGain system to operate in an auto-framing (AUTO) mode in which it continuously searches the input DS1 bit stream for a valid SF or ESF frame pattern. This feature is required for fractional DS1 applications (DS0 blocking) where it insures proper channel time slot alignment. While the HiGain system can also process unframed data in this AUTO mode, it is recommended that the unframed (UNFR) mode be used for all unframed applications. Using the AUTO mode for unframed applications runs the risk of detecting pseudo-valid frame sequences, which can affect the data integrity.
		UNFR	Configures the HiGain system to operate in an unframed mode. This mode disables the auto framing process and forces the HiGain system to function as a transparent bit pipe.
AIS on HDSL LOSW See "AIS on HDSL LOSW Option" on page 24.	HAIS	2LP	Causes the HiGain system to transmit the AIS signal at both the HLU-319 and HRU DS1 output ports when both of the HDSL loops are not in sync (LOSW).
		1LP	Causes the HiGain system to transmit the AIS signal at both the HLU-319 and HRU DS1 output ports when either of the two HDSL loops is not in sync (LOSW) or if a Margin alarm occurs.
AIS on SMJK/NREM	SAIS	ENA	Causes the HRU to transmit the AIS signal towards the Customer Interface (CI) when in NREM or SmartJack loopback.
		DIS	Causes the HRU to either transmit the signal from the network towards the CI RCV port or to open and terminate its RCV CI port when an HRU NREM or SmartJack loopback is executed. The AIS signal is not sent (towards the CI).
DS0 Blocking See "DS0 Blocking Option" on page 23.	DS0	BLK	The DS0 blocking option can only be set through a maintenance terminal connected to the craft port. The four-character front-panel display only shows the status of the blocking option. BLK indicates at least one channel is blocked.
		NONE	Indicates no channels are blocked.
Margin Alarm Thresh See "Margin Alarm Thresh Option" on page 24.	MARG	0 to 15 dB	The Margin Alarm Threshold can only be set through a maintenance terminal connected to the craft port. It determines the minimum allowable margin below which a system alarm can occur. Zero disables the alarm.
		4 dB	Default value.
RLOS (DS1 LOS) Alarm	RDA	ENA	Enables a remote DS1 LOS condition at the input to the HRU to generate an LOS alarm. AIS or LOS (depending on ALMP) is sent towards the network.
		DIS	Prevents a remote DS1 LOS condition at the input to the HRU from causing an LOS alarm. The front-panel Status LED still flashes red and the ALRM RLOS message is displayed but the alarm relay contacts do not close and LOS is sent towards the network from the HLU-319 instead of AIS.
Alarm Pattern	ALMP	AIS	Enables HiGain to output an AIS payload at its DS1 ports for LOSW, DS1 LOS and Margin alarms.
		LOS	Enables HiGain to output an LOS condition at its DS1 ports for LOSW, DS1 LOS and Margin alarms.

Continued

Table 8. HLU-319 List 5F System Settings (Continued)

System Settings Screen Options	Front-Panel Display Code	Parameter	Description
Remote Provision	RTPV	ENA	Enables remote provisioning.
		DIS	Disables remote provisioning.
BPVT See "BPVT Option" below.	BPVT	ENA	Enables BPVs and HDSL CRC errors at the DS1 input to be converted into DS1 BPVs at the distant end's DS1 output. This makes HiGain transparent to BPVs.
		DIS	Disables BPVT.

Equalization Option

Equalization is the configuration of system transmission characteristics within specified limits. An adaptive equalizer inserts a frequency-shaped loss that corresponds to an equivalent addition of an appropriate cable length. By simulating the additional cable loss necessary for correct operation, the equalizer compensates for a range of variation in transmission path characteristics.

BPVT Option

The HLU-319 List 5F improves HiGain's compatibility with Digital Loop Carrier (DLC) feeder applications because of its ability to transmit DS1 BPV occurrences between its DS1 interfaces. This feature is required to support protection switching in DLC applications. Each DLC terminal must be able to monitor the integrity of its Receive DS1 payload and then switch to the protected line when the integrity of the path drops below specific user-selected limits. An essential requirement of this feature is the need for each DLC terminal to detect BPVs in its DS1 input. Standard HDSL systems correct DS1 BPVs at the input and thus prevent them from being detected by the DLC terminals to which they are connected. The HLU-319 and its associated remote units remove this limitation and become BPV transparent by detecting and counting input BPVs at each end and then replicating them at the DS1 output port of the distant end.

This BPVT option is controlled by the BPVT user option, which allows it to be Enabled (ENA) or Disabled (DIS).



When BPVT is enabled in systems with four or less doublers, the response time to an HDSL LOSW is approximately 70 ms, which gives DLC terminals time to react and avoid dropped calls.

In addition, the CRCs in each direction of every HDSL loop of each span are also counted and added in with the BPV count to produce a Total Error Count (TEC) that indicates the integrity of both the DS1 and HDSL paths. A TEC in each direction is calculated each second by adding the number of BPVs to the number of HDSL CRCs in that direction. The maximum TEC count is 12000. This TEC number is converted into BPVs at the distant end during the following second at a rate of 1 BPV every 128 DS1 bits up to a maximum of 12000 ($BER=7.7 \times 10^{-3}$). This maximum rate is more than adequate since it exceeds the maximum 10^{-3} BER required by most DLC systems.

BER Alarm Thresh Option

The BER option also uses this (BPV/CRC) TEC to generate an Alarm if enabled. The HLU-319 combines the 1-second TEC counts in both directions for the last 60 seconds. It uses this 1-minute Total System Error Count (TSEC) to generate an alarm if it exceeds the selected BER threshold of (1E-6 or 1E-7) as follows:

- BER option = 1E-6. Alarm is generated if TSEC > 93
- BER option = 1E-7. Alarm is generated if TSEC > 9

Once initiated, the alarm clears when the TSEC drops below its associated threshold count. For dribbling errors, the alarm can come and go in intervals as short as 1 second. Alarms caused by bursty impulse noise transients usually require the full 60 seconds or longer to clear depending on the frequency of the transients. This BER option is always present in any line unit circuit since it is independent of other versions of HiGain modules in the circuit. When connected to an HRU, other than the HRU-402, only the BVPs detected by the HLU-319 are included in the TEC. The BPVs at the HRU are not counted.

DS0 Blocking Option

To set the DS0 Blocking option from the Main screen:

- 1 Press **C** to select the Systems Settings screen (see [Figure 8 on page 19](#)).
- 2 Press **O** for the DS0 blocking selection. The DS0 channels are blocked or unblocked by entering each channel number. Multiple channels can be selected by inserting a space between each entry.
- 3 After all the new settings have been made, press **E**. The **C** (confirm) message displays in the lower, left-hand corner of the screen. Press **C** to confirm the changes or press any other key to ignore changes.
- 4 The new choices are now installed.

If DS0 blocking is invoked in a HiGain system that has an earlier version HRU that does not support the blocking option, blocking only occurs at the DSX-1 output of the HLU-319 List 5F. The HRU DS1 output is not blocked. Also, all blocked channels are temporarily unblocked for all HiGain system loopback tests for all DS1 blocking settings. This allows the standard full bandwidth DS1 loopback tests to be performed for all DS0 blocking settings.

If any of the unused DS0 channels of a fractional T1 service are filled with information other than an idle code of all ones, the HiGain system blocks this information from reaching the remote end of the circuit and replaces those DS0 channels with an idle code of all ones.

Blocking the idle code results in a mismatch between the CRC checksum delivered to the remote end (when the payload is in the ESF format) and the checksum calculated by the remote DS1 CSU. This implies that errors are being made on the loop when actually the blocking function created the CRC errors. Enabled DS0 channels pass error-free.

In order to avoid this condition, fractional T1 customers should fill the unused time slots with an idle code. This is a common capability on Fractional T1 CSU/DSU, D4 channel banks, and other CPE devices capable of connecting to Fractional T1 service.

DS1 Line Code Option

The DS1 line code option should always be set to conform to the type of DS1 service (AMI or B8ZS) being provided by the HiGain system. The AUTO mode is capable of adapting to either AMI or B8ZS. Because the AUTO mode induces one BPV in the DS1 bit stream whenever it switches from AMI to B8ZS, it should only be used in applications that require this mode of operation (i.e., HiGain that act as a standby circuit to DS1 circuits where the line codes are either unknown or can be both AMI and B8ZS). The AUTO mode allows both the HLU-319 and the HRU to set its DS1 output code to that which is being received at the opposite end's DS1 input. This forces the input and the output codes in each direction of transmission to be identical. In the AUTO mode of older HiGain units, the output code was determined by the input code being received at the local DS1 input port instead of at the distant end. The HLU-319 reverts to this older code setting technique when it is not connected to an HRU-402.

Margin Alarm Thresh Option

To set the Margin Alarm Threshold:

- 1 Press **P** to select the System Settings screen.
- 2 Enter the desired minimum acceptable alarm threshold from the 0 to 15 dB range. This causes a system alarm to occur if either the margin on HDSL Loop 1 (MAL1) or Loop 2 (MAL2) drops below the selected threshold value.
- 3 Press **E** to exit.
- 4 Press **C** to confirm.



Since the margin can never drop below zero, choosing **0** (zero) for the margin threshold turns the margin alarm off.

AIS on HDSL LOSW Option

The AIS on HDSL LOSW option provides two selections for the T1 transmit outputs at both the HLU-319 and HRU for HDSL loss of sync conditions.

- **1LP**, selected from the front-panel display, causes the AIS (LOS if ALMP is set to LOS) pattern to be transmitted at both T1 outputs when either of the two HDSL loops experience an out-of-sync (LOSW) condition or when a margin alarm occurs. 1LP causes the 12 channels on the surviving loop to be lost as they are replaced by the AIS/LOS pattern. However, it does notify downstream and upstream equipment of the loss of one HDSL loop or a loop with low margin. This is the preferred setting for initiating an AIS/LOS state with just one conductor open in either of the HDSL pairs. Short loops, below approximately 16 dB of loss at 200 kHz, can remain in sync with one conductor open. Since the loop is still in sync, no LOSW condition occurs. However, the margin on a one-conductor loop drops from 5 to 10 dB. Thus, if the Margin alarm is set to 5 dB below the normal margin at turn-up, when one conductor does open, a system alarm occurs and causes the AIS/LOS condition. This alerts the maintenance personnel of the problem.
- **2LP**, selected from the front-panel display, requires both HDSL loops to be out of sync (LOSW) before the HAIS signal is transmitted. 2LP preserves the integrity of the 12 surviving channels when just one loop is lost.

HDSL Line Voltage Options

The Power option has four settings for HDSL line power feed: DIS, LOW, AUTO, and HIGH.

- **DIS** disables any voltage from being applied to the HDSL cable pairs. It is useful to prevent craft personnel from being exposed to the HDSL line voltage when they are working on the cable pairs.
- **LOW** limits the HDSL simplex voltage to -135 Vdc maximum. This is the standard voltage used in all non-doubler applications and has no effects in these applications. It can be chosen to limit line-powered, single-doubler circuits or locally powered, two-doubler circuits up to -135 Vdc, if the appropriate HiGain products (HDU-409, HDU-404 or HDU-407 and HRU-402) are used along with the HLU-319 List 5F. These HiGain units are the only ones that have sufficiently low power consumption to allow their doubler circuits to be line-powered from -135 Vdc.
- **AUTO** is the conventional mode in which the HLU-319 automatically maintains the HDSL line voltage at -135V1
- Vdc maximum for non-doubler applications and ± 112 Vdc for doubler applications.
- **HIGH** forces the HDSL line voltage to its high ± 112 Vdc level for applications. It is needed to allow the HLU-319 to power circuits that are providing power to remote Personal Communication Systems (PCS) sites.

Loopback Menu Screen

The Loopback Menu permits you to issue loopbacks to the HiGain system. Depending upon the number of doublers, there can be up to five loopback screens.

Press **D** from the Maintenance Terminal Main Menu to display the Loopback Menu screen. [Figure 9 on page 26](#) shows an example of a Loopback Menu when no doublers are present. [Figure 10 on page 26](#) shows an example when four doublers are present.

The following options are available:

- Press **A** to select the Disable Loopbacks option.
- Press **B** to select HLU-319 Network Loop.
- Press **C** to select HRU Network Loop.
- Press **G** to select HLU-319 Customer Loop.
- Press **H** to select HRU Customer Loop.
- For doubler applications, additional loopback selections appear on the screen.
- Press **E** to exit and return to the previous menu.

[Table 9](#) lists the HLU-319 List 5F loopback field messages and descriptions.

Table 9. *Loopback Field Messages and Descriptions*

Messages	Full Name	Description
NREM	Network Remote Loopback	Loopback at HRU (remote) towards network.
NLOC	Network Local Loopback	Loopback at HLU (local) towards network.
CLOC	Customer Local Loopback	Loopback at HRU (local) towards CI.
CREM	Customer Remote Loopback	Loopback at HLU-319 (remote) towards CI.
NDU n	Network Doubler n Loopback	Loopback at n^{th} doubler towards network.
CDU n	Customer Doubler n Loopback	Loopback at n^{th} doubler towards CI.

Loopback Menu without Doubler

```
                                LOOPBACK MENU

TIME: 01:19:07
DATE: 11/15/00
CIRCUIT ID#:

      A. DISABLE LOOPBACKS
      B. NETWORK LOOP HLU      (NLOC)
      C. NETWORK LOOP HRU      (NREM)
      G. CUSTOMER LOOP HLU      (CREM)
      H. CUSTOMER LOOP HRU      (CLOC)

                                (E)xit
```

Figure 9. Loopback Menu: No Doubler

Loopback Menu for Doubler Applications

```
                                LOOPBACK MENU

TIME: 00:03:33
DATE: 11/15/00
CIRCUIT ID#:

      A. DISABLE LOOPBACKS
      B. NETWORK LOOP HLU      (NLOC)      M. NETWORK LOOP DOUBLER 4 (NDU4)
      C. NETWORK LOOP HRU      (NREM)      N. CUSTOMER LOOP DOUBLER 4 (CDU4)
      D. NETWORK LOOP DOUBLER 1 (NDU1)
      F. NETWORK LOOP DOUBLER 2 (NDU2)
      G. CUSTOMER LOOP HLU      (CREM)
      H. CUSTOMER LOOP HRU      (CLOC)
      I. CUSTOMER LOOP DOUBLER 1 (CDU1)
      J. CUSTOMER LOOP DOUBLER 2 (CDU2)
      K. NETWORK LOOP DOUBLER 3 (NDU3)
      L. CUSTOMER LOOP DOUBLER 3 (CDU3)

                                (E)xit
```

Figure 10. Loopback Menu: Four Doublers

Initiating a Loopback

To send one of the available loopbacks, press the appropriate letter in the Loopback Menu. The following prompt appears:

PLEASE WAIT.....

A series of dots moves from left to right indicating that the command has been issued. When this process completes, the system returns to the Maintenance Terminal Main Menu. The selected loopback four letter designation now appears in the Loopback Mode field in the Maintenance Terminal Main Menu (see [Figure 11](#) in which an NLOC loopback is in progress). The loopback continues to cycle in the system depending upon your Loopback Timeout setting.



The Loopback Menu screen is also available at the HRU connected to the HLU-319 List 5F, allowing all HiGain System loopbacks to be initiated from either end of the circuit.

```

HI-GAIN HLU-319      MAINTENANCE TERMINAL MAIN MENU   (ver V7.5L-8)
                     CIRCUIT ID#:

                     A. VIEW SPAN STATUS
                     B. SET CLOCK
                     C. SYSTEM SETTINGS
                     D. LOOPBACK MODE:  NLOC
                     E. VIEW PERFORMANCE DATA
                     F. VIEW PERFORMANCE HISTORY
                     G. VIEW ALARM HISTORY
                     H. VIEW SYSTEM INVENTORY
                     I. VIEW TROUBLESHOOTING

```

Figure 11. NLOC Loopback Mode Reported in the Maintenance Terminal Main Menu

Disabling a Loopback

The Disable Loopbacks option ([Figure 9 on page 26](#)) allows you to disable (cancel) any of the loopbacks listed in the screen. To disable loopbacks, press **A** in the Loopback Menu. The following prompt appears:

PLEASE WAIT.....

A series of dots moves from left to right indicating that the command has been issued. When this process completes, the system returns to the Maintenance Terminal Main Menu where the Loopback Mode option is identified as None.

View Performance Data Screen

The Performance Data screen shows the Errored Seconds (ES) and Unavailable Seconds (UAS) for both HDSL loops and each DS1 input at 15-minute intervals over a 4-hour time interval. (The ES and UAS data is separated by a slash mark.) Earlier and later data, in 4-hour time periods on different span screens, can be accessed by pressing **P** (Previous) or **N** (Next) respectively. Errored and unavailable seconds are defined in [Table 10](#) below.

Press **E** at the Maintenance Terminal Main Menu to view the Performance Data screen. From each Performance Data screen, you can do the following:

- Press **P** to view the previous 4-hour data screen.
- Press **N** to view the next 4-hour data screen.
- Press **S** to view the next available span (for doubler applications).
- Press **1**, **2**, **3**, **4**, or **5** to select a specific span (for doubler applications).
- Press **E** to exit.



All Performance Data counters can be set to zero by pressing **C (Clear) from the HLU-319 Span Status screen shown in [Figure 5 on page 14](#). The HLU-319 is considered the master module; it clears all performance data screens at both the HLU-319 and the HRU. Counters cannot be cleared by accessing the HRU craft port.**

Table 10. Errored and Unavailable Seconds Definitions

ES and UAS	Definition
HDSL Errored Second	A second in which at least one HDSL CRC has occurred.
HDSL Unavailable Second	A second in which an HDSL loop experiences loss of sync at least once.
DS1 Errored Second	A second in which at least one BPV, CRC, FRM error, or LOS has occurred.
DS1 Unavailable Second	A second in which at least one DS1 LOS condition (175 ± 75) zeros has occurred.

Performance Data Screen without Doubler

Figure 12 shows a single non-doubler span. This screen shows the Errored and Unavailable Seconds for the HDSL span between the HLU-319 and the HRU.

```

Date: 11/15/00      PERFORMANCE DATA
CIRCUIT ID#:

                ERRORED SECONDS/UNAVAILABLE SECONDS

                DS1                HDSL-1                HDSL-2
                HLU      HRU      HLU      HRU      HLU      HRU
00:00  ---/---  ---/---  ---/---  ---/---  ---/---  ---/---
00:15  ---/---  ---/---  ---/---  ---/---  ---/---  ---/---
00:30  /        /        /        /        /        /
00:45  /        /        /        /        /        /
01:00  /        /        /        /        /        /
01:15  /        /        /        /        /        /
01:30  /        /        /        /        /        /
01:45  /        /        /        /        /        /
02:00  /        /        /        /        /        /
02:15  /        /        /        /        /        /
02:30  /        /        /        /        /        /
02:45  /        /        /        /        /        /
03:00  /        /        /        /        /        /
03:15  /        /        /        /        /        /
03:30  /        /        /        /        /        /
03:45  001/    002/002  004/014  006/    003/013  007/001

                (E)xit (P)revious (N)ext
    
```

Figure 12. Performance Data Screen: No Doubler

Performance Data Screen for Doubler Applications

Figure 13 is an example of a Performance Data screen that lists performance data for the fifth span (HDU4 to the HRU).

```

Date: 11/15/00      SPAN 5 PERFORMANCE DATA
CIRCUIT ID#:

                ERRORED SECONDS/UNAVAILABLE SECONDS

                DS1                HDSL-1                HDSL-2
                HLU      HRU      HDU4      HRU      HDU4      HRU
20:15  ---/---  ---/---  ---/---  ---/---  ---/---  ---/---
20:30  ---/---  ---/---  ---/---  ---/---  ---/---  ---/---
20:45  /        /        /        /        /        /
21:00  /        /        /        /        /        /
21:15  /        /        /        /        /        /
21:30  /        /        /        /        /        /
21:45  /        /        /        /        /        /
22:00  /        /        /        /        /        /
22:15  /        /        /        /        /        /
22:30  /        /        /        /        /        /
22:45  /        /        /        /        /        /
23:00  /        /        /        /        /        /
23:15  /        /        /        /        /        /
23:30  /        /        /        /        /        /
23:45  /        /        /        /        /        /
00:00  /        /        /        /        /        /

                (E)xit (P)revious (N)ext (S)pan(1)(2)(3)(4)(5)
    
```

Figure 13. Performance Data Screen: Four Doublers (Span 5)

View Performance History Screen

The Performance History screen shows the daily occurrences of ES and UAS over a 31-day period in 24-hour increments. Errored Seconds and Unavailable Seconds for both HDSL loops and each of the two DS1 inputs are listed for the current and previous period.

Press **F** at the Maintenance Terminal Main Menu to open the Performance History screen. This screen shows the ES and UAS for the HDSL loop between the HLU-319 and the HRU.

From the Performance History screen, you can do the following:

- Press **S** to advance through the history screens for the various spans (for doubler applications).
- Press **N** (Next) for a continued history.
- Press **P** (Previous) for the previous screen.
- Press **E** to exit from the Performance History screen.



All Performance History counters can be set to zero by pressing **C** (clear) at the HLU-319 Span Status screen shown in [Figure 5 on page 14](#). The HLU-319 is considered the master module; it clears all performance data screens at both the HLU-319 and the HRU. Counters can not be cleared by accessing the HRU craft port.

Performance History Screen without Doubler

[Figure 14](#) shows a non-doubler application.

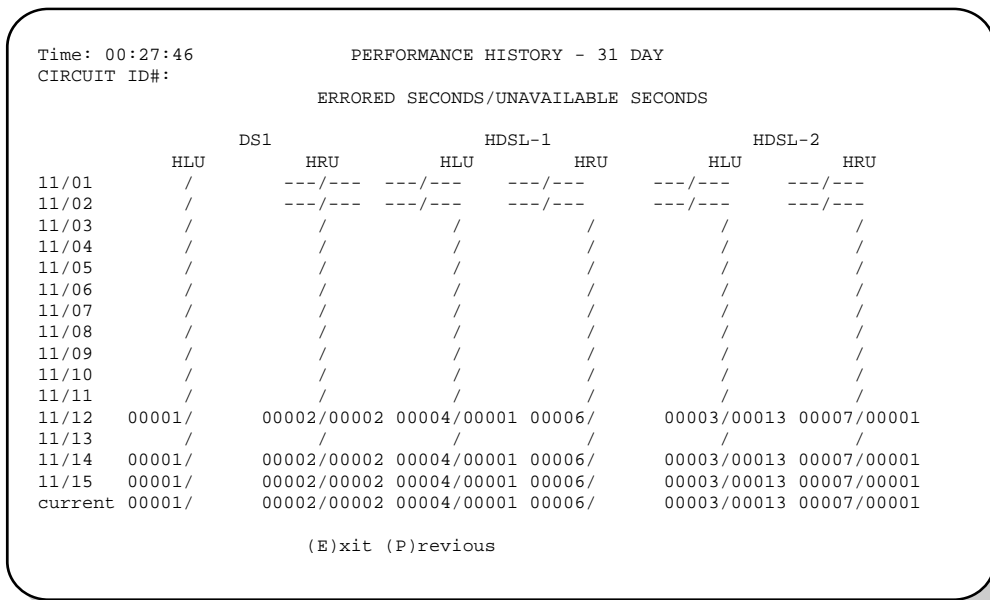

Figure 14. 31-Day Performance History Screen: No Doubler

Performance History Screen for Doubler Applications

The Performance History screen displays information by span when doublers are present. With multiple doublers (up to four), there can be as many as five span screens.

```

Time: 00:26:29          SPAN 5 PERFORMANCE HISTORY - 31 DAY
CIRCUIT ID#:
                                ERRORED SECONDS/UNAVAILABLE SECONDS

                                DSL-1          HDU4          HDU4          HDU4          HDU4          HDU4
                                HLU          HRU          HDU4          HDRU          HDU4          HRU
11/01  ---/---          ---/---          ---/---          ---/---          ---/---          ---/---
11/02  ---/---          ---/---          ---/---          ---/---          ---/---          ---/---
11/03  /              /              /              /              /              /
11/04  /              /              /              /              /              /
11/05  /              /              /              /              /              /
11/06  /              /              /              /              /              /
11/07  /              /              /              /              /              /
11/08  /              /              /              /              /              /
11/09  /              /              /              /              /              /
11/10  /              /              /              /              /              /
11/11  /              /              /              /              /              /
11/12  /              /              /              /              /              /
11/13  00001/          /              00005/00001  /              00035/00492  /
11/14  /              /              ---/---          ---/---          ---/---          ---/---
11/15  00001/          00002/00002  00004/00001  00006/          00003/00013  00007/00001
current 00001/          /              00005/00001  /              00035/00492  /

                                (E)xit (P)revious (S)pan(1)(2)(3)(4)(5)

```

Figure 15. 31-Day Performance History Screen: Four Doublers (Span 5)

View Alarm History Screen

Press **G** at the Maintenance Terminal Main Menu to open the Alarm History screen. This screen allows you to view alarms that are currently active. The Alarm History screen (Figure 16 and Figure 17 on page 33) provides the following information:

- First and Last columns contain the date and time stamp of the first and last occurrence of each alarm.
- Current column shows the status of each alarm.
- Count column lists the number of times each alarm occurred. (The maximum non-overflowing count is 999.)

From each Alarm History screen you can do the following:

- Press **U** to update the screen.
- Press **S** to view another span (for doubler applications).
- Press **C** to clear all data from the screen.
- Press **1**, **2**, **3**, **4**, or **5** to select a specific span (for doubler applications).
- Press **E** to exit from the screen.

Table 11 lists the Alarm History fields and descriptions. These descriptions apply to the alarm history for doubler applications as well.

Table 11. Alarm History Fields and Descriptions

Field	Description
Type	Identifies the type of alarm
LOS, DS1-HLU-319	First and last instance of LOS at the HLU-319, current condition, number of alarms.
LOS, DS1-HRU	First and last instance of LOS at the HRU, current condition, number of alarms.
BER	First and last instance of a BER at the HRU, current condition, number of alarms.
Span(n) LOSW, HDSL1	First and last instance of LOSW on HDSL1, current condition, number of alarms.
Span(n) LOSW, HDSL2	First and last instance of LOSW on HDSL2, current condition, number of alarms.
Span(n) Margin L1	First and last instance when margin dropped below the established threshold on Loop 1, current condition, number of alarms.
Span(n) Margin L2	First and last instance when margin dropped below the established threshold on Loop 2, current condition, number of alarms.
PWR-SHRT	Power short condition, current condition, number of alarms.
PWR-GND	Power ground condition, current condition, number of alarms.
Last Cleared	Last time Alarm History cleared, current condition, number of alarms.

Alarm History Screen without Doubler

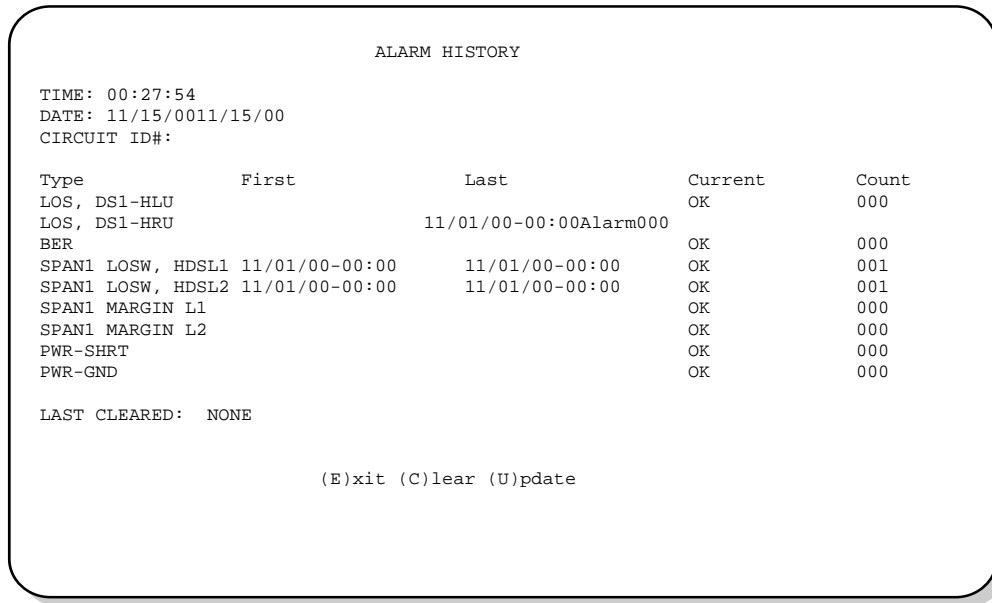

Figure 16. Alarm History Screen: No Doubler

Alarm History Screen for Doubler Applications

The Alarm History screen displays information by span. With no doubler, there is only one span (Figure 16). With multiple doublers (up to four), there can be as many as five span screens. Figure 17 is an example of an Alarm History screen that lists history for the fifth span (Doubler #4 to the HRU).

```

                                ALARM HISTORY

TIME: 13:59:20
DATE: 11/15/00
CIRCUIT ID#:

Type           First           Last           Current       Count
LOS, DS1-HLU           OK           000
LOS, DS1-HRU           OK           000
BER                    OK           000
SPAN5 LOSW, HDL1 11/01/00-00:00 11/01/00-00:00 OK           001
SPAN5 LOSW, HDL2 11/01/99-00:00 11/01/00-00:00 OK           001
SPAN5 MARGIN L1 11/01/99-00:00 11/01/00-00:00 OK           001
SPAN5 MARGIN L2 11/01/99-00:00 11/01/00-00:00 OK           001
PWR-SHRT              OK           000
PWR-GND                OK           000

LAST CLEARED: 11/10/00-13:49

(E)xit (C)lear (U)pdate (S)pan(1)(2)(3)(4)(5)

```

Figure 17. Alarm History Screen: Four Doublers (Span 5)

View System Inventory Screen

The System Inventory screen (Figure 18 on page 34) lists the six possible units that can comprise one HiGain circuit: one HLU-319, one HRU, and up to four doublers. The information in the System Inventory screen is presented as follows:

- All six possible unit modules are always listed. The doublers are shown as: DB1, DB2, DB3, DB4.
- The model number, list number, and software revision number of every unit in the circuit are listed in the Product column. Units that are not detected are not considered to be present in the circuit and are labeled N/A.
- Unit ID numbers are limited to 24-character alphanumeric characters. To change an ID number, select its line-identifying letter. The ID numbers, like the system settings, are stored in NVRAM and, therefore, remain when power is lost.
- The HLU-319 has no unit ID number since it is usually identified by the Circuit ID number, which appears in every screen.
- All detected modules have the product number listed. Whenever the HLU-319 loses sync with Span 1, the product types are replaced by the N/A label until sync is reestablished. Each module can then be reidentified. Only the Circuit ID number appears in the other HLU-319 Maintenance Terminal screens.

Press **H** at the Maintenance Terminal Main Menu to display the System Inventory screen (Figure 18 and Figure 19 on page 35).

From each System Inventory screen (depending on the number of doublers), you can do the following:

- 1 Select the unit for which you want to set the circuit ID by pressing the letter that precedes the unit name.
- 2 Type the circuit ID number, then press **ENTER**.
You can use up to 24 alphanumeric characters for the circuit ID. If more than 24 characters are entered, a warning beep is emitted and only the first 24 characters are accepted.
- 3 To set the circuit ID for another unit, repeat [Step 1](#) and [Step 2](#).

- 4 Press **E** to exit the System Inventory screen.
The system prompts you to confirm the circuit ID number.
- 5 Press **C** to confirm the circuit ID and exit the System Inventory screen.



Executing the default option from either the front panel or the System Settings screen has no effect on the ID values.

System Inventory Screen without Doubler

```

                                SYSTEM INVENTORY
TIME: 00:21:10
DATE: 11/15/00          A. CIRCUIT ID:

UNIT      PRODUCT      CLEI      UNIT ID
HLU  HLU-319 L5F V7.5  T1L4FXLB  NOT REQUIRED
B. HRU  HRU-402 L1 V1.4      N/A
C. DB1  N/A
D. DB2  N/A
F. DB3  N/A
G. DB4  N/A

                                (E)xit
Enter the item letter to change any ID
```

Figure 18. System Inventory Screen: No Doubler

```

TIME: 00:31:30          TROUBLESHOOTING with HELP
DATE: 11/15/00         CIRCUIT ID#:

  >>>> |-----| 1 |-----| 1 |-----| 1 |-----| 1 |-----| 1 |-----| >>>>
  <<<<< |-----| 2 |-----| 2 |-----| 2 |-----| 2 |-----| 2 |-----| <<<<<
NTWK  HLU   HDU1  HDU2  HDU3  HDU4  HRU   CUST

          SYSTEM OPERATIONAL

SYMBOLS  DESCRIPTIONS          TROUBLESHOOTING
) (      Loopback              ) - Network loopback; ( - Customer loopback
X        HDSL loop not in sync  Bad connection
(M)      Low Margin Alarm       Poor HDSL signal, long loop, interference
(I)      High Insertion Loss    Long loops, bridged taps
(C)      HDSL Errored Second    Shorts, interference, noise
(N)      HDSL Unavailable Second Shorts, interference, noise
R        Channel Reversal      Channel Reversal nearest HLU is displayed
E(R)R    DS1 Errored Second     Errors include BPV, framing and CRC
L(O)S    DS1 Unavailable Second  Loss of T1 signal
AIS      Alarm Indication Signal Far end LOS, HDSL LOSW, loopbacks or MAL

AUTOUPDATE ON          (E)xit (A)uto(U)pdate (B)ack (L)oopbacks

```

Figure 22. Troubleshooting with Help

- Press **M** to display margin values for the circuit (Figure 23).

```

TIME: 00:36:10          TROUBLESHOOTING with MARGIN VALUES
DATE: 7/15/00         CIRCUIT ID#:

  >>>> |-----| 18 17 |-----| 17 16 |-----| 16 17 |-----| 16 16 |-----| 16 18 |-----| >>>>
  <<<<< |-----| 18 17 |-----| 16 16 |-----| 16 17 |-----| 17 17 |-----| 15 18 |-----| <<<<<
NTWK  HLU   HDU1  HDU2  HDU3  HDU4  HRU   CUST

          MARGIN

Margin is the signal-to-noise ratio at the HDSL transceiver.

An M symbol on the diagram indicates a margin lower than 4 dB.

Low margin is a result of high noise level and/or low HDSL signal level.

Some causes of low margin:
- Long loop
- External interference
- Excessive cross-talk

AUTOUPDATE ON          (E)xit (A)uto(U)pdate (B)ack (L)oopbacks

```

Figure 23. Troubleshooting with Margin Values

- Press **I** to display the insertion loss values for the circuit (Figure 24).

```

TIME: 00:37:10          TROUBLESHOOTING with INSERTION LOSS VALUES
DATE: 11/15/00          CIRCUIT ID#:
  >>>> | 35 36 | 36 36 | 37 36 | 36 36 | 36 36 | 36 36 | >>>>
  <<<< | ===== | ===== | ===== | ===== | ===== | <<<<
  <<<< | ===== | ===== | ===== | ===== | ===== | <<<<
NTWK  | 33 36 | 36 36 | 36 37 | 36 36 | 36 36 | 36 36 |
      HLU   HDU1  HDU2  HDU3  HDU4  HRU   CUST

```

INSERTION LOSS

Insertion loss is the attenuation of the HDSL signal at 196 kHz.
Pulse attenuation is directly related to insertion loss.

An I symbol on the diagram indicates an insertion loss of 38 dB or higher.

High insertion loss is a result of a low HDSL signal reception.

Some causes of high insertion loss:

- Long loop
- Bridged taps

AUTOUPDATE ON (E)xit (A)uto(U)pdate (B)ack (L)oopbacks

Figure 24. Troubleshooting with Insertion Loss Values

TESTING

This section provides information about system alarms and loopback testing. In addition to these troubleshooting aids, the Maintenance Terminal provisioning interface includes troubleshooting screens (see “[View Troubleshooting Screen](#)” on page 35) that provide a basic graphical analysis of system problems.

FRONT-PANEL SYSTEM ALARMS

Table 12 lists possible HLU-319 List 5F alarm states and the corresponding front-panel messages. More than one alarm condition can exist at any given time, but only one message can be displayed. For multiple alarms, only the highest priority alarm displays.

Table 12. HDSL System Alarms

Front-Panel Message ^(a)	Alarm	Description	To Inhibit:
LOSW	Loss of Sync Word ^(b)	One of the HDSL loops has lost synchronization.	Cannot be inhibited.
LLOS	Local Loss of Signal	Loss of the DSX-1 input signal.	Cannot be inhibited.
RLOS	Remote Loss of Signal	Loss of the HRU DS1 input signal.	Disable the RDA (Remote DS1 Alarm) option. This prevents an LOS condition at the DS1 input to a HRU from closing the alarm contacts (pins H). The front-panel Status LED still flashes red and the ALRM RLOS message displays to alert you of the LOS state. LOS is sent towards the network from the HLU-319. This option prevents the common occurrences of a CPE LOS condition from generating recurring alarms and AIS payloads.
R(L)AIS ^(c)	Remote (or Local) Alarm Indicating Signal	Indicates an AIS pattern of all ones is being transmitted (XMT) from the remote (or local) DS1 output port.	Cannot be inhibited.
MAL1 or MAL2	Margin Alarm Loop1 or Margin Alarm Loop2	The margin on HDSL Loop 1 or Loop 2 has dropped below the minimum threshold value set by the terminal MARGIN ALARM THRES.	Set the Margin Alarm Threshold option to 0 (zero).
BER	Bit Error Rate exceeded	The combined DS1 and HDSL BER has exceeded the set threshold limits of 10^{-6} or 10^{-7} .	Select NONE for the BER system option.
NONE	No alarm	No current alarm condition.	Cannot be inhibited.

(a) The ALRM message appears prior to any alarm message.

(b) When both HDSL loops lose sync word (LOSW), a system alarm condition exists. However, since the HLU-319 enters a self test cycling mode, the front-panel LED lights yellow instead of red and the SELF TEST message displays instead of the ALRM message.

(c) This message is reported in the Span Status screens, but not on the front-panel display.

Alarm Option for DLC Feed

To improve HiGain compatibility with the switch-to-protect features used in DLC feeder applications, the HLU-319 has an Alarm Pattern Option (ALMP) that allows you to select either an AIS or LOS DS1 output payload for the following alarms:

- LOSW on any loop
- LOS DS1
- Margin alarm if HAIS = IL

Retiring System Alarms

To retire a system alarm, press the SEL pushbutton to execute an Alarm Cutoff (ACO). An ACO turns the alarm off and replaces the ALRM message with an ACO message. The second part of the ALRM message, which defines the cause of the alarm, remains. Both parts of the message remain until the alarm condition clears or another higher priority alarm occurs.

Self Test

The Self Test mode that occurs when both HDSL loops are not in sync has been enhanced to include the input DS1 transceiver chip. The Self Test procedure can cause the all ones pattern that is normally transmitted from the HLU-319 during these out of sync intervals to exhibit occasional BPVs.

LOOPBACK OPERATION

HiGain has a family of loopback options for analyzing circuit functionality. The loopback signal is transmitted and returned to the sending device for comparison. This allows you to verify the integrity of the HDSL channels to the HLU-319, the HLU-319 DSX-1 interface and the DS1 channels to the customer. Loopback options include:

- Generic Loopback (GNLB) options, including the SmartJack (SMJK) option (see [Table 13 on page 41](#))
- Special Loopback (SPLB) options (see [“Special Loopback Commands” on page 42](#)):
 - Addressable Repeater Loopback commands: A1LB, A2LB, A5LB (see [Table 14 on page 46](#))
 - Addressable Repeater Loopback commands: A3LB, A4LB (see [Table 15 on page 49](#))

Loopback commands can be initiated by:

- Selecting the loopback type using the MODE and SEL pushbuttons on the HLU-319
- Selecting the loopback type from the Maintenance Terminal Main Menu when connected to the craft port of the HLU-319 or HRU
- Entering the loopback code into the test equipment connected to the HLU-319 or HRU

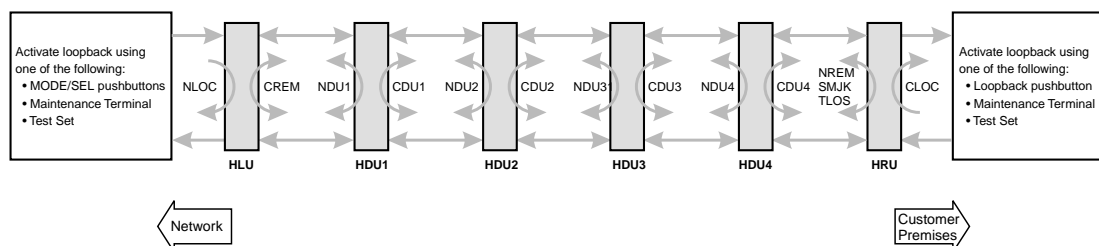

Figure 25. Loopback Summary

GENERIC LOOPBACK COMMANDS

The HiGain Generic Loopback (GNLB) commands allow you to use inband codes to loop up either NLOC (4-in-7) or NREM (3-in-7) towards the network. In addition, these inband codes loop up CREM (6-in-7) or CLOC (5-in-7) towards the customer. Either loop-up condition can be terminated (looped down) with the 3-in-5 SMJK loop-down code. All inband codes must be present for 5 seconds before the HiGain system responds. HiGain also supports NDUx doubler loopbacks to the network and CDUx doubler loopbacks towards the customer.

Figure 25 summarizes the available loopbacks in the system, and Table 13 on page 41 summarizes the HiGain generic loopback commands. See “GNLB Test Procedures” on page 44 for the test procedures that apply when using the GNLB mode.

Table 13. Summary of HiGain Loopback Codes and Activation Methods

Loopback	Code	Description	Method of Transmission		
			Test Set	Craft Port	MODE/SEL
NLOC	1111000 4-in-7	DSX-1 signal is looped back to the network at the HLU-319.	X	X	X
NDU1	110000 2-in-6	DSX-1 signal is looped back to the network at the NDU1.	X	X	X
NDU2	111000 3-in-6	DSX-1 signal is looped back to the network at the NDU2.	X	X	X
NDU3	1010001	DSX-1 signal is looped back to the network at the NDU3.	X	X	X
NDU4	1010010	DSX-1 signal is looped back to the network at the NDU4.	X	X	X
NREM	1110000 3-in-7	DSX-1 signal is looped back to the network at the HRU.	X	X	X
CLOC	1111100 5-in-7	DS1 signal from customer is looped back to the customer at the HRU.	X	X	X
CDU1	1111100 4-in-6	DS1 signal from customer is looped back to the customer at the CDU1.	X	X	X
CDU2	1111110 5-in-6	DS1 signal from customer is looped back to the customer at the CDU2.	X	X	X
CDU3	1011001	DS1 signal from customer is looped back to the customer at the CDU3.	X	X	X
CDU4	1011010	DS1 signal from customer is looped back to the customer at the CDU4.	X	X	X
CREM	1111110 6-in-7	DS1 signal from customer is looped back to the customer at the HLU-319.	X	X	X
SMJK LpUp (PL)	11000 2-in-5	SmartJack Loopup or NID payload (PL) code. DSX-1 signal is looped back to the network at the HRU SmartJack module.	X		
SMJK LpUp (ESF-DL)	1111-1111- 0100-1000	SmartJack Loopup or NID (ESF-DL) code. DSX-1 signal is looped back to the network at the HRU SmartJack module.	X		
SMJK LpDn (PL)	11100 3-in-5	SmartJack Loopdown or NID payload (PL) code. Removes SMJK, NLOC, NREM, CREM, CLOC, CDU _n , and NDU _n .	X		
SMJK LpDn (ESF-DL)	1111-1111- 0010-0100	SmartJack Loopdown or NID (ESF-DL) code. Removes SMJK, NLOC, NREM, CREM, CLOC, CDU _n , and NDU _n .	X		



HiGain systems feature the SmartJack option, which can emulate a Network Interface Device (NID) for loopback testing of the HiGain circuit. SMJK and NREM loopbacks perform the same functions but their initiation differs. SMJK indicates that the loopback was initiated by the 2-in-5 inband command. NREM, on the other hand, is initiated by the 3-in-7 inband command or by a command issued from the maintenance terminal or the MODE and SEL pushbuttons.

Use the inband commands to enable or disable the SMJK loopback options. The HLU-319 system setting is normally enabled to recognize all inband SmartJack loopback commands.

SPECIAL LOOPBACK COMMANDS

In addition to the GNLB loopback command mode, a HiGain system can be configured for one of five special loopback command modes. These loopbacks are selected from the maintenance terminal System Settings screen (see [Table 8 on page 20](#)) or by using the MODE and SEL pushbuttons (see [Figure 26 on page 45](#)). Once a loopback mode is activated, other loopback commands can be sent by a test set connected to the craft port of the HLU-319 or HRU (see [Table 14 on page 46](#) and [Table 15 on page 49](#) for list of SPLB commands).

A1LB through A5LB are five special, addressable, repeater loopback modes which are supported by the HLU-319 List 5F. These loopback modes provide the HiGain system with sophisticated maintenance and troubleshooting tools. A1LB, A2LB, and A5LB are patterned after the Teltrend addressable DS1 repeater loopbacks. A3LB and A4LB are patterned after the Wescom addressable DS1 repeater loopbacks. All five SPLBs have been enhanced to handle the specific requirements of the following HiGain customers:

- A1LB (Teltrend) = Southwestern Bell
- A2LB (Teltrend) = Southwestern Bell
- A3LB (Wescom) = New England Telephone
- A4LB (Wescom Mod 1) = New York Telephone
- A5LB (Teltrend Mod 1) = Southern New England Telephone (SNET), Southwestern Bell, Pacific Bell

The A1LB loopback selection complies with the one proposed for HDSL systems in the T1E1.4/92 recommendation with the following additions:

- Query loopback
- IOR (Intelligent Office Repeater) power-down
- Four loopback time-out choices
- Initiation from either end
- Repeating bit error signatures
- Alternate query loopback

These additions make A1LB identical to A2LB. A1LB is given a separate identity to allow future DS1/E1 enhancements to be added without affecting A2LB.

A5LB differs from A2LB in that A5LB does not block the arming code from exiting the HLU-319 into the network. A2LB can be configured to do one of the following:

- Block the arming code (after 2 seconds) from exiting the HLU-319 into the network and replace it with the AIS code.
- Unblock the AIS code by executing the Far End Activate code. (Since A5LB never blocks the arming code from exiting the HLU-319, the Far End Activate code is not available in A5LB.)

A3LB differs from A4LB in that A3LB supports the additional (1-in-6) SMJK loopback command.



A HiGain system may take longer than normal to respond to inband loopback commands when its framing mode is set to UNFR and the inband commands are set in either SF or ESF mode. The frame bits override the command bits and cause errors in the command sequence. These errors cause the HiGain system to reject some sequences.

MANUAL LOOPBACK SESSION

A manual loopback session allows you to select any one of the HiGain GNLB loopbacks listed in [Table 13 on page 41](#) with the exception of SmartJack loopbacks, which can only be issued by inband commands.

Setting the Loopback Time-out Option

Before initiating a loopback session, verify that the Loopback Time-out parameter is set to the desired setting.

- 1 Use the MODE and SEL pushbuttons as described in “[Setting Options through SEL and MODE](#)” on [page 9](#).
(The Loopback Time-out parameter is also user-selectable from the System Settings screen when using a maintenance terminal.)
- 2 Enter the desired setting:
 - NONE (no time-out)
 - 20 minutes
 - 60 minutes (default setting)
 - 120 minutes

Activating Manual Loopback Mode



With the exception of SmartJack, any of the HiGain loopbacks can be executed using the MODE and SEL pushbuttons.

When executing a manual loopback session using the MODE and SEL pushbuttons:

- The next loopback option can be presented by pressing the MODE pushbutton, however, the previously activated loopback remains active until the SEL pushbutton is pressed, which activates the new loopback.
- If neither pushbutton is pressed for a period of 30 seconds and no loopback is in effect, the manual loopback session terminates and the display returns to normal mode.
- If any loopback is in effect, the 30-second time-out is inhibited. The active loopback and the manual loopback session continue until the loopback times out in accordance with the LBTO setting.
- If there is an active loopback, pressing the MODE and SEL pushbuttons for 3 or more seconds terminates any active loopback, ends the manual loopback session and returns the display to normal mode.

To initiate a manual loopback session:

- 1 Press both the MODE and SEL pushbuttons on the front panel for at least 3 seconds. The following message appears on the front-panel display:
MAN LPBK NLO?
- 2 Press SEL to activate NLOC. The display changes to MAN LPBK NLOC.

- 3 Press MODE to advance to the next available loopback (ND1?, ND2?, ND3?, ND4?, NRE?, CRE?, CD1?, CD2?, CD3?, CD4? or CLO?).
- 4 Press SEL to activate the selected loopback. The previous loopback is terminated.

Once a loopback is selected and activated, it stays active until it times out (based on the LBTO setting). When a loopback times out, the display then returns to the normal display mode.

You can terminate loopbacks manually and exit the MAN LPBK mode by simultaneously pressing the MODE and SEL pushbuttons for 3 or more seconds. If no loopback is active, the MAN LPBK mode automatically terminates after 30 seconds.

All loopbacks can be initiated by inband commands in the DS1 payload or by a command from the HiGain system (front-panel pushbuttons or maintenance screen selections). Therefore, whenever a loopback is active, the method, by which it was activated is indicated, in the Loopback and Status screens by the annotation HG (HiGain) or PL (Payload) adjacent to the identified loopback. For example, NREM (HG) indicates that the loopback was initiated by the HiGain system.



SMJK loopback commands are only activated by inband commands.

LOOPBACK TEST PROCEDURES

The following sections provide step-by-step test procedures for verifying the integrity of the HDSL channels at every module location as well as the DS1 channels to the customer and the local DSX-1 interface.

General Troubleshooting Tips

If trouble is encountered on the DSX-1 interface of the HLU-319, verify that the:

- HLU-319 is making a positive connection with its mounting assembly (shelf) connector.
- HLU-319 internal equalizer is set to the correct distance range per [Table 8 on page 20](#). All equalizers should be set to the distance from the DSX-1 to the shelf.

The transmit and receive DSX-1 ports have splitting access jacks and miniature, 210-series, bridging jacks as shown in [Figure 1 on page 3](#). Connecting one cable between the two bridging jacks and another between the two SPAN jacks splits the XMT and RCV and creates metallic loopbacks towards both the DSX-1 and the HLU-319. If separate plugs are inserted into both SPAN jacks with the other end disconnected, the BRG jacks can be used to send and receive test patterns towards the DSX-1.

GNLB Test Procedures

[Figure 26 on page 45](#) is a graphical representation of the various generic loopback configurations with the associated GNLB commands shown. Also, refer to [Table 13 on page 41](#) for a description of these commands.

To perform the GNLB loopback test procedure:

- 1 Have the CO tester send the NREM (3-in-7) inband loopup code for 5 seconds. You should be able to observe the NREM message on the front-panel display. (The Status LED on the front panel should be green, and the loopback mode should also be identified on the Span Status screen.)
- 2 Have the CO tester transmit a DS1 test signal towards the HLU-319 and verify that the returned (looped) signal to the test set is error-free.
- 3 If [Step 2](#) fails, have the CO tester transmit the (3-in-5) inband loopdown code.

- 4 Have the CO tester send the NLOC (4-in-7) inband loopup for 5 seconds. You should be able to observe the NLOC message on the front-panel display. (The Status LED on the front panel should be yellow, and the loopback mode should also be identified on the Span Status screen.)
- 5 Repeat Step 2. If the test passes, the error is in the downstream direction. If the test fails, the error is in the upstream direction.

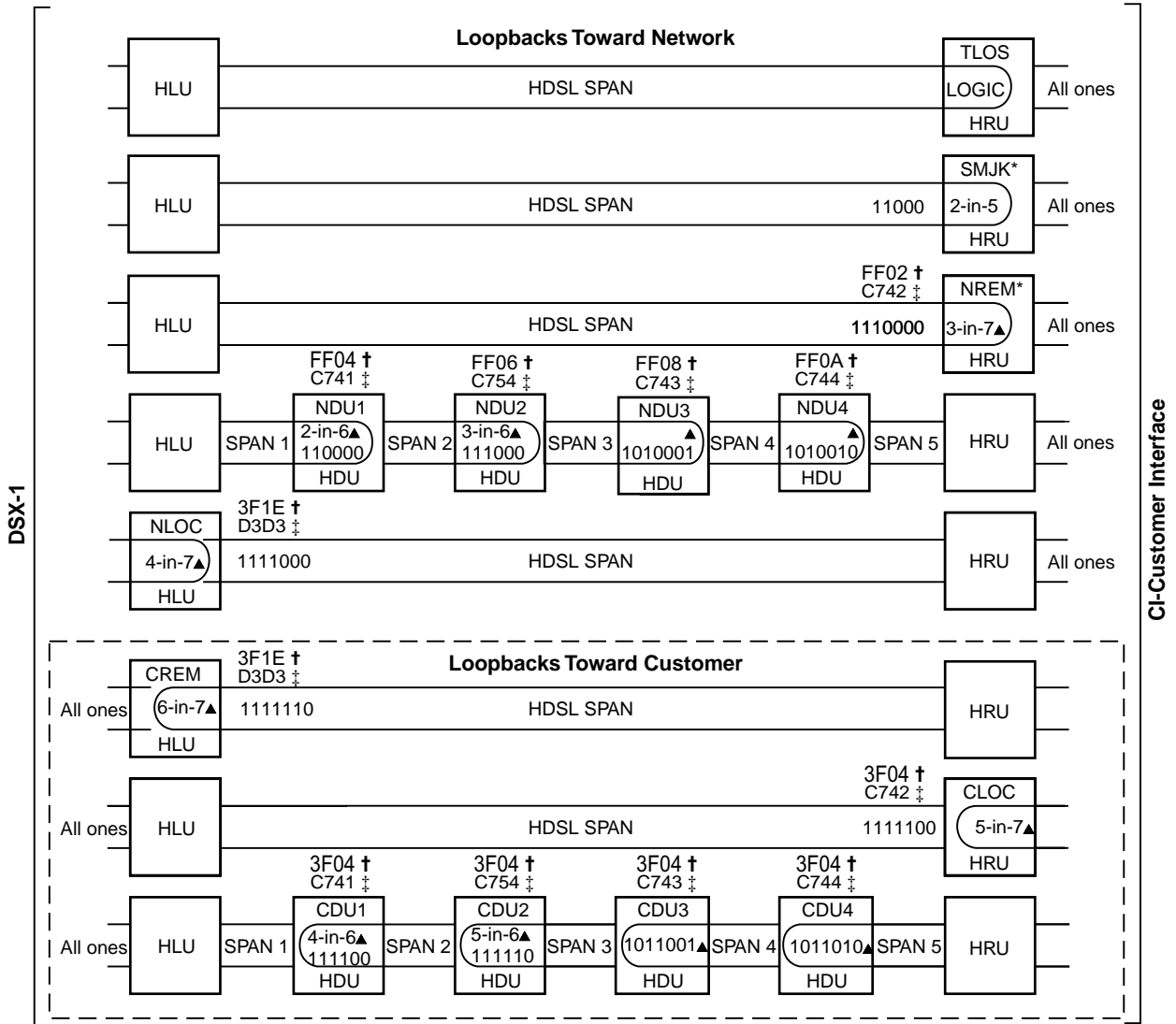

* Set the SAIS option to ENA to send AIS (indicated by an all ones pattern) to the CI during SmartJack loopback, NREM, and TLOS. Use the 3-in-5 code to loop down.
 † A3LB and A4LB loopback codes.
 ‡ A1LB, A2LB, and A5LB loopback codes.
 ▲ GNLB loopback codes.

Figure 26. Loopback Modes

A1LB, A2LB, and A5LB Test Procedures

Using the codes listed in [Table 14](#), a network tester can activate NLOC, NDU_n , or NREM loopbacks (or SMJK, if enabled). A tester at the customer premises can activate CLOC, CDU_n , or CREM loopbacks. All loopbacks shown in [Table 14](#) can also be initiated from the HLU-319 front-panel MODE and SEL pushbuttons (see “[Setting Options through SEL and MODE](#)” on page 9). Information specific to HiGain doublers is shown in bold type.

Table 14. *Addressable Repeater Loopback Commands (A1LB, A2LB, A5LB)*

Loopback Commands	Binary Code ^(a) (Hexadecimal Equivalent)	Description
ARMING or NI LPBK (inband)	11000-11000 ...	Arming code
ARMING or NI LPBK (ESF Data Link)	1111-1111-0100-1000 (FF48)	Arming code
IR LPDN or DISARM (inband)	11100-11100 ...	Disarming code
IR LPDN or DISARM (ESF Data Link)	1111-1111-0010-0100 (FF24)	Disarming code
IOR LPBK (NLOC and CREM 230-232 bit errors and 229-231 bit errors) ^(b)	1101-0011-1101-0011 (D3D3)	NLOC—DSX-1 signal is looped back to the network at the HLU-319. CREM—DS1 signal from customer is looped back to the customer at the HLU-319.
ILR-1 LPBK (10 bit errors) ^(b)	1100-0111-0100-0001 (C741)	NDU1—DSX-1 signal is looped back to the network at the NDU1. CDU1—DS1 signal from customer is looped back to the customer at the CDU1.
ILR-20 LPBK (200 bit errors)	1100-0111-0101-0100 (C754)	NDU2—DSX-1 signal is looped back to the network at the NDU2. CDU2—DS1 signal from customer is looped back to the customer at the CDU2.
ILR-3 LPBK (30 bit errors)	1100-0111-0100-0011 (C743)	NDU3—DSX-1 signal is looped back to the network at the NDU3. CDU3—DS1 signal from customer is looped back to the customer at the CDU3.
ILR-4 LPBK (40 bit errors)	1100-0111-0100-0100 (C744)	NDU4—DSX-1 signal is looped back to the network at the NDU4. CDU4—DS1 signal from customer is looped back to the customer at the CDU4.
ILR-2 LPBK (20 bit errors)	1100-0111-0100-0010 (C742)	NREM—DSX-1 signal is looped back to the network at the HRU. CLOC—DS1 signal from customer is looped back to the customer at the HRU.
IR LPDN (except SMJK)	1001-0011-1001-0011 (9393)	Loopdown (HLU-319, HDU, or HRU)
IR QUERY LPBK	1101-0101-1101-0101 (D5D5)	Query loopback
IR ALTERNATE QUERY LPBK	1101-0101-1110-1010 (D5EA)	Alternate query loopback
TIME-OUT OVERRIDE	1101-0101-1101-0110 (D5D6)	Loopback time-out override
FAR END NI ACTIVATE ^(c)	1100-0101-0101-0100 (C554)	Unblock AIS
IOR POWER DOWN (HLU-319) ^(d)	0110-0111-0110-0111 (6767)	Removes HDSL line power

- (a) The leftmost bit arrives first in all sequences. The detection algorithm functions reliably with a random 10^{-3} Bit Error Ratio (BER) on the facility. The entire arming and loopback sequence can also be initiated at the remote HRU location.
- (b) The HRU identifies CREM (and the HLU-319 identifies NLOC) with 231 bit errors, including the frame bits. When framed data is being sent in the AUTO framing mode, the number of the 231 bit errors detected by the test set varies from 229 to 231, depending on whether or not the test set counts frame errors as bit errors, and on the number of frame bits contained in the block of 231 error bits. The HRU and HLU-319 generate this bit pattern in a series of discontinuous bursts containing 20-bit errors each, including frame bits. Those test sets that do not count frame error bits as data bit errors will indicate fewer bits than the HRU and HLU-319 transmit for a CI and NI loopback.
- (c) Allows the NIU Activate Command that originates at the HRU to pass through uninhibited toward the network and is always enabled. No option to disable.
- (d) The IOR Power Down code must remain present for the duration of the power down mode. When this code is removed, the HiGain system returns to its normal unlooped and unarmed state.

To perform the A1LB, A2LB, and the A5LB test procedures:

- 1 Send the inband Arming and NI LPBK code 11000 to the HLU-319 for at least 5 seconds.
- 2 Monitor the output of the HLU-319 for the return of the pattern. Return of the pattern indicates one of the following:
 - the HRU has looped up (if the SMJK Loopback option is Enabled)
 - an external NI has looped up (if the SMJK Loopback option is Disabled), and the HLU-319 and HRU have been armed
- 3 Verify, if possible, that the HRU Loopback LED is either flashing yellow at 4-second intervals (indicating that the system is armed), or is a steady yellow (indicating that it is both armed and in SMJK loopback). The HLU-319 Status LED also flashes yellow when the system is armed.



If the Arming code is not returned after 5 seconds, the system may be armed, but there is no active loopback.

- 4 Once armed, the HLU-319 can be looped back by sending Intelligent Office Repeater (IOR) LPBK activation code 1101-0011-1101-0011 (D3D3) for at least 5 seconds. You should observe the following activation response pattern in the order presented:
 - a 2 seconds of AIS (identified by an all ones pattern)
 - b 2 seconds of returning data pattern
 - 231 errors, if ILR loopback (HLU) was sent
 - 10 errors, if ILR-1 (Doublor 1) was sent
 - 200 errors, if ILR-20 (Doublor 2) was sent
 - 30 errors, if ILR-3 (Doublor 3) was sent
 - 40 errors, if ILR-4 (Doublor 4) was sent
 - 20 errors, if ILR-2 (HRU) was sent
 - c Normal looped data

This error pattern repeats every 20 seconds as long as the IOR loopback pattern is being sent. This also applies to ILR, Time-out Override, and Query commands.



Some Intelligent Repeater (IR) test sets do not count frame errors as bit errors when the test pattern is framed and the HLU-319 is set to the Auto framing mode. To improve compatibility with those test sets, the HLU-319 generates 201 (NDU2 and CDU2) and 232 (NLOC and CREM) ID bit errors. As a result, the HLU-319 may indicate one more or one less bit error, depending on the test set type and the number of frame bits contained in the block of errored bits. To avoid this uncertainty, ADC recommends sending unframed IR commands.

The HLU-319 is now in logic loopback if the IOR NLOC loopback command was sent. The Time-out Override command or a Loopdown command can override the selection made for the loopback time-out (see “Setting the Loopback Time-out Option” on page 43). If the Time-out Override code 1101-0101-1101-0110 (D5D6) is received after activating a loopback, then the automatic timed expiration of the loopback is inhibited. If this Time-out Override is sent, then the only way to loop the HLU-319 down is to do one of the following:

- Issue the IR LPDN (loopdown) code 1001-0011-1001-0011 (9393)
- Issue the NI LPDN and Disarm inband code 11100 or the ESF-DL code (FF24).



The Time-out Override function is only valid for the current active loopback. The automatic time-out timer is restored during subsequent loopback sessions.

5 Once the test is complete, do one of the following:

- If the system is to loopdown but remain Armed, send the IR LPDN code (universal loopdown).
- If all the equipment is to be looped down, disarmed and returned to normal operation, send the disarm inband code 11100 or the ESF-DL code (FF24).



The Armed mode has an automatic time-out of 120 minutes, but this timer is reset to 120 for any of the following events:

- **Loopback terminates (manually or time-out),**
- **Query**
- **Alternate query**
- **Far End activate**
- **Another ARM command.**

This timer is inhibited while any of the valid command codes are being sent. Once the codes are removed, the timer restarts at 120.

A3LB and A4LB Test Procedures

The HLU-319 List 5F can be looped back by sending the Addressable Office Repeater (AOR) LPBK activation code 1111-1111-0001-1110 (FF1E) for at least 5 seconds. This causes the HLU-319 List 5F to enter the NLOC state. The Loopback Time-out setting (see “Setting the Loopback Time-out Option” on page 43) determines the duration of this loopback unless it is overridden by the reception of a second identical 16-bit loop-up command before the timer expires. When this time-out override state exists, the only way to loop the HLU-319 List 5F down is to issue one of the three loopdown commands listed in Table 15. The automatic time-out mode is restored during subsequent loopback sessions.

Table 15 summarizes the codes required to execute Addressable 3 and 4 (A3LB and A4LB) repeater loopback commands. All code sequences must be present for at least 5 seconds. Information specific to HiGain doublers is shown in bold.

Table 15. Addressable Repeater Loopback Commands (A3LB and A4LB)

Loopback Commands	Binary Code ^(a) (Hexadecimal Equivalent)	Description
NLOC	1111-1111-0001-1110 (FF1E)	HLU-319 loopup from NI
CREM	0011-1111-0001-1110 (3F1E)	HLU-319 loopup from CI
NDU1	1111-1111-0000-0100 (FF04)	HDU doubler 1 loopup from NI
CDU1	0011-1111-0000-0100 (3F04)	HDU doubler 1 loopup from CI
NDU2	1111-1111-0000-0110 (FF06)	HDU doubler 2 loopup from NI
CDU2	0011-1111-0000-0110 (3F06)	HDU doubler 2 loopup from CI
NDU3	1111-1111-0000-1000 (FF08)	HDU doubler 3 loopup from NI
CDU3	0011-1111-0000-1000 (3F08)	HDU doubler 3 loopup from CI
NDU4	1111-1111-0000-1010 (FF0A)	HDU doubler 4 loopup from NI
CDU4	0011-1111-0000-1010 (3F0A)	HDU doubler 4 loopup from CI
NREM	1111-1111-0000-0010 (FF02)	HRU loopup from NI
CLOC	0011-1111-0000-0010 (3F02)	HRU loopup from CI
SMJK	11000-11000-11000 ...	HRU loopup from NI
SMJK	100000 100000 100000 ...	HRU loopup from NI ^(b)
SMJK	1111-1111-0100-1000 (FF48)	HRU loopup from NI (ESF-DL)
Loopdown	11100-11100-11100 ...	HLU-319 and HRU loopdown from NI OR CI
Loopdown	100-100-100 ...	HLU-319 and HRU loopdown from NI OR CI
Loopdown	1111-1111-0010-0100 (FF24)	HLU-319 and HRU loopdown from NI OR CI (ESF-DL)

(a) The leftmost bit arrives first in all sequences. The detection algorithm functions reliably with a random 10^{-3} Bit Error Ratio (BER) on the facility. The entire arming and loopback sequence can also be initiated at the remote HRU location.

(b) Not supported by A4LB.

APPENDIX A - SPECIFICATIONS

This appendix provides general specifications, pinout diagrams for the craft port and card-edge connector, HDSL insertion loss guidelines, and power consumption and dissipation tables.

Power

HDSL Span Voltage	-135 to ± 112 Vdc
CO Supply	-48 Vdc nominal (-42.5 to -56.5 Vdc) See "Power Consumption", "Maximum Power Dissipation", and "Maximum Current Drain" beginning on page 51.
Electrical Protection	Secondary surge and power cross-protection on HDSL ports. Requires external primary protection
Fusing	Internal; connected to fuse alarm output on pin H

Environmental

Operating Temperature	-40 °F to +149 °F (-40 °C to +65 °C)
Operating Humidity	5% to 95% (non-condensing)

Physical

Height:	4.75 in. (12.1 cm)
Width:	0.625 in. (1.59 cm)
Depth:	10 in. (25.4 cm)
Weight:	8 oz. (.23 kg)
Mounting	STS high-density shelf

HDSL

Line Rate	784 kbps 2B1Q
Transmission	Full duplex
Media	Two unconditioned copper pairs
Output	+13.5 dBm ± 0.5 dB at 135 Ω
Line Impedance	135 Ω
Maximum Provisioning Loss	35 dB at 196 kHz, 135 Ω
Start-up Time	30 sec. (typical), 60 sec. (maximum) per span

DSX-1

Line Impedance	100 Ω
Pulse Output	6 V ^{pk-pk} , pre-equalized for 0-655 feet of ABAM cable
Input Level	+1.5 to -7.5 dBDSX
Line Rate	1.544 Mbps ± 200 bps
Line Format	AMI, B8ZS or ZBTISI
Frame Format	ESF, SF, or UNFR

System

One-way DS1 Delay	<200 μ s per span without doublers. Doubler delay <80 μ s
Wander (Looped)	0.5 UI maximum (1 UI = 648 ns)
Wideband Jitter (Looped)	0.2 UI maximum
Narrowband Jitter (Looped)	0.1 UI maximum

HDSL INSERTION LOSS GUIDELINES

Each loop has no more than 35 dB of loss at 196 kHz, with driving and terminating impedances of 135 Ω .

Table 16 provides a “loss” guide for the various cable gauges at 196 kHz and 135 Ω . The table applies to the HDSL cable pairs between the HLU-319, HRU, and HDU modules. In the absence of specific insertion loss measurement data, add 3 dB for each bridged tap and 1 dB for each cable gauge change.

Table 16. HDSL Loss Over Cables

Cable Gauge	Loop Loss ^(a) (dB per kft)	Loop Resistance (Ω per kft)
26 AWG/0.4 mm	3.88	83
24 AWG/0.51 mm	2.84	52
22 AWG/0.61 mm	2.18	32
19 AWG/0.91 mm	1.54	16

(a) At 196 kHz, 68°F (20°C)



A Windows-based program, **Cable Calculator**, may be downloaded at www.pairgain.com from the Customer site portion web site. If you don't have a customer password, contact your sales representative.

POWER CONSUMPTION

Power consumption and heat dissipation depend upon the type of remote and doubler units in the system and the CPE power setting.

Power Consumption without Doublers

The three most important power parameters of an HLU-319 are its maximum power consumption, its maximum power dissipation, and its maximum current drain.

Table 17 describes line-powered circuits on 9 kft, 26 AWG loops without a doubler.

Table 17. HLU-319 Power Parameters—No Doubler

HRU Model No.	HRU CPE Power	42.5 Vdc Power Consumption (Watts)		Heat Dissipation (Watts)		42.5 Vdc Current (mA)	
		Typical	Maximum	Typical	Maximum	Typical	Maximum
HRU-412 List 1, 2, 3, 4	ON	12.0	13.2	5.1	5.6	284	312
HRU-412 List 1, 2, 3, 4	OFF	11.0	12.1	5.0	5.5	260	286
HRU-412 List 6, 7, 8	ON	12.6	13.9	5.2	5.7	297	327
HRU-412 List 6, 7, 8	OFF	9.7	10.7	4.5	4.9	228	251
HRU-402	N/A	7.7	8.5	4.5	4.9	182	200

Power Consumption with Doublers

Table 18 through Table 24 list the power consumed and dissipated by the HLU-319 when it is used with any of the four basic doubler types in the HiGain family. The maximum current drawn by the CO supply is also listed.

Table 18 through Table 20 show power parameters for single doubler, line-powered circuits on 9 kft, 26 AWG loops.

Table 18. HLU-319 Power Parameters—Single Doubler (HDU-451 List 1 or 2)

HRU Model No.	HRU CPE Power	42.5 Vdc Power Consumption (Watts)		Heat Dissipation (Watts)		42.5 Vdc Current (mA)	
		Typical	Maximum	Typical	Maximum	Typical	Maximum
HRU-412 List 1, 2, 3, 4	ON	27.5	30.3	7.6	8.4	646	711
HRU-412 List 1, 2, 3, 4	OFF	25.9	28.5	7.2	7.9	610	671
HRU-412 List 6, 7, 8	ON	27.7	30.5	7.6	8.4	651	716
HRU-412 List 6, 7, 8	OFF	24.3	26.7	7.1	7.8	571	628
HRU-402	N/A (OFF)	21	23.1	6.3	6.9	494	543

Table 19. HLU-319 Power Parameters—Single Doubler (HDU-439 or HDU-437 Lists 1 and 1B)

HRU Model No.	HRU CPE Power	42.5 Vdc Power Consumption (Watts)		Heat Dissipation (Watts)		42.5 Vdc Current (mA)	
		Typical	Maximum	Typical	Maximum	Typical	Maximum
HRU-412 List 1, 2, 3, 4	ON	22.3	24.5	7.9	8.6	525	578
HRU-412 List 1, 2, 3, 4	OFF	21.4	23.5	7.8	8.5	502	552
HRU-412 List 6, 7, 8	ON	22.3	24.5	8.0	8.8	524	576
HRU-412 List 6, 7, 8	OFF	19.2	21.1	7.3	8.1	452	497
HRU-402	N/A (OFF)	16.0	17.6	6.7	7.4	376	414

Table 20. HLU-319 Power Parameters—Single Doubler (HDU-409 List 2)

HRU Model No.	HRU CPE Power	42.5 Vdc Power Consumption (Watts)		Heat Dissipation (Watts)		42.5 Vdc Current (mA)	
		Typical	Maximum	Typical	Maximum	Typical	Maximum
HRU-412 List 1, 2, 3, 4	ON	18.8	20.7	7.0	7.7	442	486
HRU-412 List 1, 2, 3, 4	OFF	18.0	19.8	7.1	7.8	424	466
HRU-412 List 6, 7, 8	ON	18.4	20.2	6.9	7.6	433	476
HRU-412 List 6, 7, 8	OFF	15.7	17.3	6.8	7.4	370	407
HRU-402	N/A (OFF)	12.5	13.8	5.9	6.5	294	323

Table 21 through Table 23 show power parameters for two doubler, line-powered circuits on 9 kft, 26 AWG loops.

Table 21. HLU-319 Power Parameters—Two Doublers (HDU-451 List 3, 4, 3B or 4B)

HRU Model No.	HRU CPE Power	42.5 Vdc Power Consumption (Watts)		Heat Dissipation (Watts)		42.5 Vdc Current (mA)	
		Typical	Maximum	Typical	Maximum	Typical	Maximum
HRU-402	N/A (OFF)	28.3	31.1	8.3	9.1	665	732

Table 22. HLU-319 Power Parameters—Two Doublers (HDU-439 or HDU-437 Lists 1 and 1B)

HRU Model No.	HRU CPE Power	42.5 Vdc Power Consumption (Watts)		Heat Dissipation (Watts)		42.5 Vdc Current (mA)	
		Typical	Maximum	Typical	Maximum	Typical	Maximum
HRU-412 List 1, 2, 3, 4	OFF	30.3	33.3	8.0	8.8	713	784
HRU-412 List 6, 7, 8	OFF	28.1	30.9	7.7	8.5	660	726
HRU-402	N/A (OFF)	24.8	27.3	7.2	7.9	584	642

Table 23. HLU-319 Power Parameters—Two Doublers (HDU-409 List 2)

HRU Model No.	HRU CPE Power	42.5 Vdc Power Consumption (Watts)		Heat Dissipation (Watts)		42.5 Vdc Current (mA)	
		Typical	Maximum	Typical	Maximum	Typical	Maximum
HRU-412 List 1, 2, 3, 4	ON	24.4	26.8	7.2	7.9	575	633
HRU-412 List 1, 2, 3, 4	OFF	22.1	24.3	6.8	7.5	520	572
HRU-412 List 6, 7, 8	ON	25.9	28.5	7.4	8.1	609	670
HRU-412 List 6, 7, 8	OFF	20.2	22.2	6.4	7.0	476	524
HRU-402	N/A (OFF)	17.4	19.1	7.1	7.8	410	451

Table 24 shows power parameters for three doubler, line-powered circuits or four doubler, locally powered circuits on 9 kft, 26 AWG loops.

Table 24. HLU-319 Power Parameters—Three and Four Doublers (HDU-409 List 2)

HRU Model No.	HRU CPE Power	42.5 Vdc Power Consumption (Watts)		Heat Dissipation (Watts)		42.5 Vdc Current (mA)	
		Typical	Maximum	Typical	Maximum	Typical	Maximum
HRU-402, 3-doubler, line-powered	N/A (OFF)	22.9	25.2	8.1	8.9	539	593
HRU-402, 4-doubler, local power	N/A (OFF)	23.7	26.1	8.0	8.8	557	613

MAXIMUM POWER DISSIPATION

The maximum power dissipation measures the power that is converted into heat that builds up within the unit. It contributes to the total heat generated in the space around the unit. It is used to determine the maximum number of fully loaded shelves per bay that does not exceed the maximum allowable power dissipation density in watts per square foot to comply with GR-63.

In COs, the maximum power dissipation for open-faced, natural convection-cooled mountings is limited to 134.7 watts per square foot in accordance with GR-63-CORE. The footprint of a standard 28-slot, 23-inch HCS-417 shelf is 7.024 square feet. Thus, the maximum bay dissipation is limited to 946 watts. Use this limit and the parameters in [Table 17](#) through [Table 24](#) to determine the maximum number of HLU-319 circuits that can occupy one CO bay.



This is a worst case situation since it assumes the entire CO is subjected to the maximum power density. More favorable conditions would permit increasing the number of shelves per bay without jeopardizing the CO thermal integrity.

The thermal loading limitations imposed when using the HLU-319 in a Controlled Environmental Vault (CEV) or other enclosures are determined by applying its power parameters to the manufacturer's requirements for each specific housing.

The 48 Vdc power consumption is the maximum total power that the HLU-319 consumes or draws from the shelf power source. This parameter is needed when the HLU-319 is in a location remote to the CO it is serving. It determines the battery capacity required to maintain an 8-hour, stand-by battery reserve for emergency situations. Battery capacity, therefore, limits the maximum number of line units that can be installed in a remote enclosure. Use the data in [Table 17](#) through [Table 24](#) to perform this analysis on a case by case basis.

MAXIMUM CURRENT DRAIN

The maximum current drain is the maximum current drawn from the shelf power supply when it is at its minimum voltage (-42.5 Vdc). This drain determines the shelf fusing requirements. Use the 42.5 Vdc current data in [Table 17](#) through [Table 24](#) to determine the shelf fusing requirements for your particular HLU-319 applications.

LOOP ATTENUATION

Each loop has no more than 35 dB of loss at 196 kHz, with driving and terminating impedances of 135 Ω (see [Table 25](#) below).

Table 25. HDSL2 Cable Attenuation Chart

Cable Gauge	Loss at 196 kHz (dB/kft)	Ω per kft
26/0.4 mm	3.88	83
24/0.51 mm	2.84	52
22/0.61 mm	2.18	32
19/0.91 mm	1.54	16

HLU-319 LIST 5F CARD CONNECTOR

Figure 27 shows the card-edge connectors on the HLU-319 List 5F. Active pins are highlighted in black.

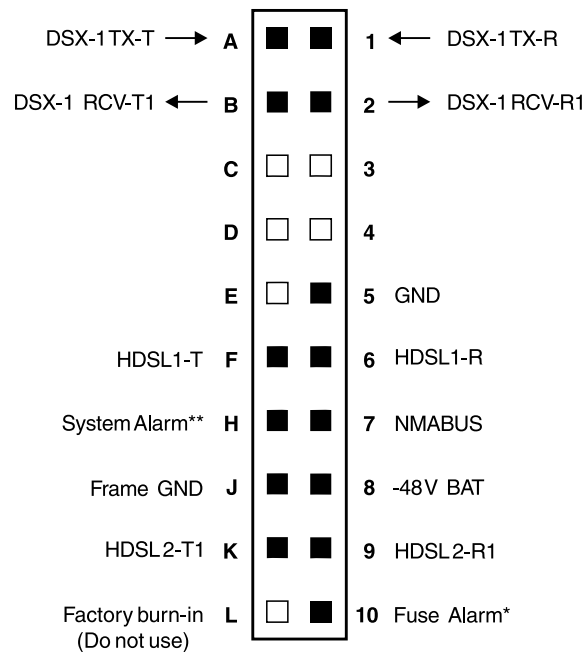

* Fuse Alarm
Normal = Floating (0 to -60 Vdc Maximum)
Activated = -48 Vdc (10 mA Maximum)

** System Alarm
Normal = Floating (+5 to -60 Vdc Maximum)
Activated = +5 Vdc (10 mA Maximum)

Figure 27. HLU-319 List 5F Card-Edge Connector

Network Management Control Bus

The HLU-319 List 5F provides a Network Management Control Bus on pin 7 of the card-edge connector. This bus allows the various ADC management system protocols to manage the HLU-319 through the HMU-319 HiGain Management Unit. Whenever the HLU-319 is under management, the MNGD message appears periodically on the HLU-319 front-panel display.



Some HLU-319 List 5F features are affected when it is under management. Consult the management unit practice for further information (see [“Appendix D - Service and Support”](#) on page 61).

Fuse Alarm

Pin 10 on the card-edge connector is a Fuse Alarm that is driven to -48 Vdc whenever its onboard fuse opens. It emulates the function of the Fuse Alarm output from pin 10 on normal, high-density (HD) repeaters. Pin 10 is connected to pin 5 of the 1184 Alarm Card (slot 1 in the HD shelf) and causes the 1184 Fuse ALM LED to light when the pin 10 signal is activated. Its normally floating output must never be driven above ground or below -80 V. It can sink a current of 10 mA. The HLU-319 does not support the BPV function (pin E) of normal HD repeaters.

System Alarm Relay Output

Pin H on the card-edge connector (see [Figure 27 on page 55](#)) is the HLU-319 System Alarm output pin. The following notes apply to pin H:

- Pin H replaces the Local Loss of Signal (LLOS) on normal high-density (3192) repeaters.
- The normally floating output of pin H can connect to pin 1 of the 1184 or 3192-9F Alarm Card in position 29 of the High Density (HD) shelf.
- The HLU-319 forces pin H to +5Vdc (maximum of 10 mA) for a system alarm condition. Pin H then remains at +5 Vdc for the duration of the alarm condition.
- If the Wescom 1184 Alarm Card is installed in the shelf, its LOS LED lights for every MNRALM.
- The HLU-319 Status LED flashes red for the duration of a system alarm condition.
- Setting the ALM option to DIS only prevents the system alarm bus on pin H from being activated for a system alarm event. The Status LED still flashes red and the ALRM message still displays.



Pin H must never be taken above +5 Vdc or below -60 Vdc.

CRAFT PORT

Figure 28 shows the pinout for the craft port connection and its connection to a DB-9 or DB-25 connector on a maintenance terminal.

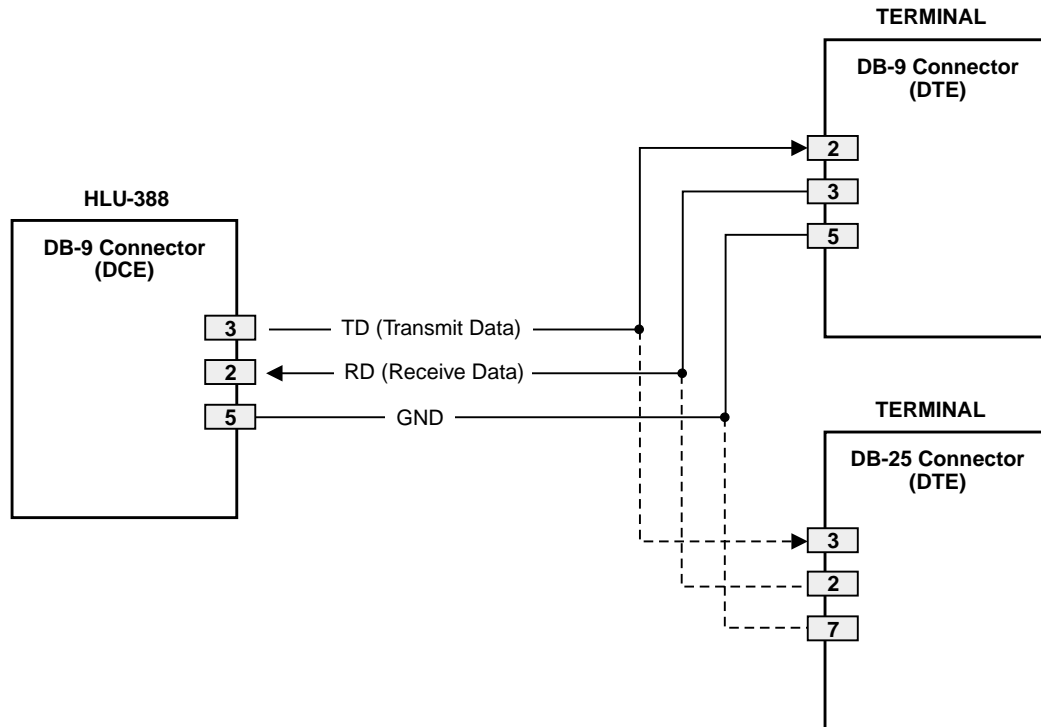

Figure 28. RS-232 Craft Port Pinouts

APPENDIX B - FUNCTIONAL OPERATION

ADC HDSL technology provides full-duplex services at standard DS1 rates over copper wires between an HLU-319 and an HRU, which comprise one HiGain system. HiGain systems use ADC 2-Binary 1-Quaternary (2B1Q) HDSL transceiver systems to establish two, full-duplex, 784 kbps data channels between the HLU-319 and a remotely located HDU or HRU. This provides a total capacity of 1.568 Mbps between the two units.

A block diagram of the HLU-319 is shown in Figure 29. The HLU-319 receives a 1.544 Mbps DSX-1 data stream from the DSX-1 digital cross connect interface. The HLU-319 contains a DS1 frame synchronizer controlled by an 8-bit microprocessor that determines the type of framing on the DS1 stream and synchronizes to it. The HLU-319 recognizes Superframe (SF), including D4, or Extended Superframe (ESF) framing. When the data is unframed, the HLU-319 arbitrarily defines a frame bit.

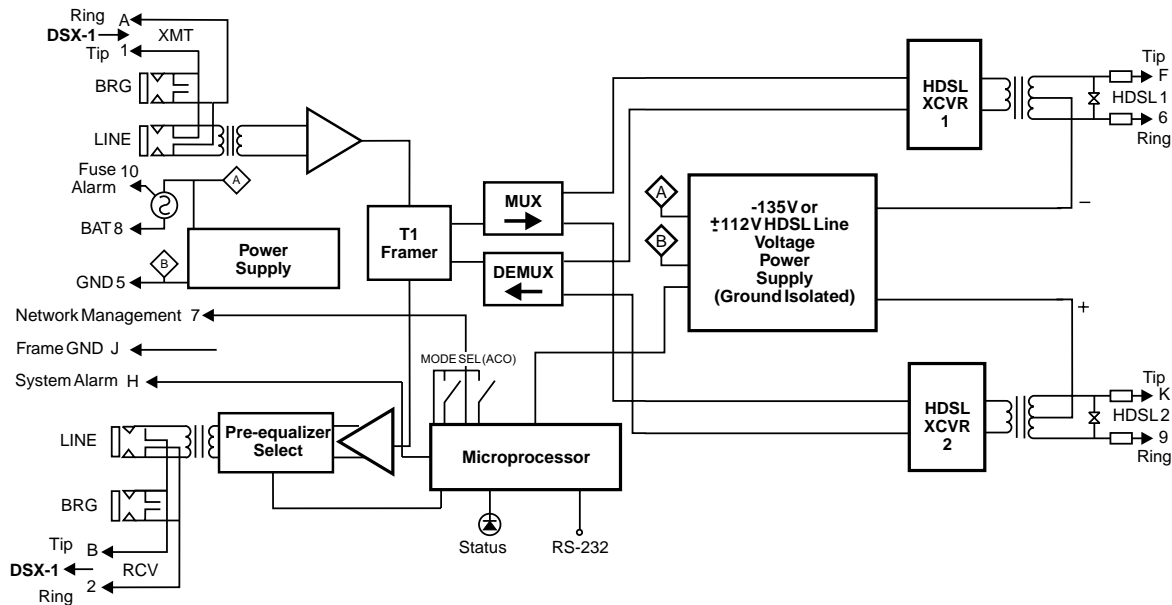

Figure 29. HLU-319 List 5F Block Diagram

TIMING

The low loop wander (0.5 UI max) of an HLU-319, when used with compatible doublers (HDU-409, HDU-404, or HDU-407) and a remote unit (HRU-402), allows the circuit to be used in all critical timing applications, including those that are used to transport Stratum 1 timing.

GROUND FAULT DETECT

The HLU-319 has a Ground Fault Detect (GFD) circuit which detects a ground or a resistive path to ground on any wire of any loop of any span with a non-zero voltage. This makes the product compliant with the Class A2 requirements of GR-1089.

APPENDIX C - COMPATIBILITY

The HiGain system uses HDSL transmission technology as recommended by Bellcore TA-TSY-001210. The HiGain system complies with GR-63-CORE, TR-TSY-000499, and GR-1089-CORE.

DS1 REPEATER SHELVES AND RELATED EQUIPMENT

The HLU-319 is compatible with the following DS1 repeater shelves and associated equipment:

- ADC HMS-357 (28-slot, 23 inch WBS-3190 shelf)
- ADC HMS-358 (28-slot, 23-inch enhanced WBS-3190 shelf)
- ADC HMS-317 (28-slot, 23-inch shelf)
- ADC HHS-319 (3-slot, 19-inch horizontal shelf)
- ADC HMS-308 (8-slot remote enclosure)
- Charles Ind. #3192 (28-slot connectorized)
- Charles Ind. #3192-9F Alarm Card
- Larus #1185 (28-slot connectorized)
- Larus #1184 Alarm Card
- Charles Ind. #3192-WR (28-slot wire wrap)
- Charles Ind. #343-00 (12- to 14-slot wire wrap)
- Charles Ind. #319-02 (22-slot connectorized)
- Charles Ind. #319-04 (22-slot wire wrap)
- Charles Ind. #340-00 (9- to 11-slot wire wrap)



The Charles Ind. 343-00 and 340-00 shelves do not support the HLU-319 System Alarm output on pin H. Also, if slots 1 and 2 of these shelves were wired for the 3408 Fault Locate unit, they must be rewired to accept the HLU-319.

HIGAIN DOUBLER CIRCUIT DEPLOYMENT

All generations of HiGain HLU-319 and HRU modules are compatible with each other. Although all HiGain doublers are backward-compatible with all prior HLU-319 and HRU models, some of the circuit application enhancements of newer doubler models require that all circuit modules be of the same vintage in order to realize these enhancements. Enhanced doubler applications preclude the mixing of newer doubler models with older models of the HRU and HLU-319 List 5F.

Table 26 on page 60 provides a matrix of HiGain doubler deployment rules to achieve maximum circuit enhancement. It lists:

- Maximum number of doublers allowed for a given circuit, depending upon the doubler and line unit models used to implement the circuit.
- Any restrictions on the HRU models.



All spans are fully CSA-compliant unless otherwise specified. Circuits that use more than one type of doubler are governed by the most limiting doubler rules. For example, if the HDU-451 is used with the HDU-409, use the HDU-451 deployment rules.

Table 26. HiGain Doubler Deployment Matrix

Maximum Number of Doublers Per Circuit												
HLU-319 Model	HDU-451, List 3, 3B, 4, 4B				HDU-437, 439				HDU-404, 407, 409			
	Line Powered		Local Powered		Line Powered		Local Powered		Line Powered		Local Powered	
	I-CPE ON	I-CPE OFF	I-CPE ON	I-CPE OFF	I-CPE ON	I-CPE OFF	I-CPE ON	I-CPE OFF	I-CPE ON	I-CPE OFF	I-CPE ON	I-CPE OFF
HLU-319-231 List 3D/6D HLU-319-319 List 2X; HLU-319-388 List 2X	1	1	2	2	1	1	2	2	1	1	2	2
HLU-319-231, List 7X; HLU-319-431, List 1D	1	1	2	2	1	2 ^(a)	2	2	1	2	2	2
HLU-319-231, Lists 8/8D/8E; HLU-319-319, Lists 5/5D/5E; HLU-319-388 Lists 5/5D/5E	1	2 ^(b)	2	2	1	2	2	2	2	3 ^(b)	2	4 ^(c)
HLU-319-431 List 1F	0	0	1	1	0	0	1	1	1	1	1	2

(a) 2000 Ω maximum loop resistance. Requires HRU-412, List 7A, List 8A or HRU-402.

(b) Requires HRU-402.

(c) Requires a locally powered HRU-402.

APPENDIX D - SERVICE AND SUPPORT

ADC Customer Service Group provides expert pre-sales and post-sales support and training for all its products.

TECHNICAL SUPPORT

Technical support is available 24 hours a day, 7 days a week by contacting the ADC Wireline Systems Division Customer Service Engineering Group at one of the following numbers:

Telephone:	800.638.0031 or 714.730.3222 The 800 telephone support line is toll-free in the U.S. and Canada.
Fax:	714.832.9924
Email:	wsd_support@adc.com

A Customer Service Engineer answers technical assistance calls Monday through Friday between 7:30 AM and 5:30 PM, Pacific Time, excluding holidays. At all other times, an on-duty Customer Service Engineer returns technical assistance calls within 30 minutes.

RETURNS

To return equipment to ADC Wireline Systems Division:

- 1 Locate the number of the purchase order under which the equipment was purchased. You will need to provide this number to ADC Wireline Systems Division Customer Service to obtain a return authorization.
- 2 Call or write ADC Wireline Systems Division Customer Service to ask for a Return Material Authorization (RMA) number and any additional instructions. Use the telephone number, fax number, or email address listed below:
 - Telephone: 800.370.9670
 - Fax: 714.832.9923
 - Email Address: rma@adc.com
- 3 Include the following information, in writing, along with the equipment you are returning:
 - Company name, address, telephone number, and the name of a person Customer Service can contact regarding this equipment.
 - The purchase order number provided to Customer Service when the RMA number was requested.
 - A description of the equipment, as well as the number of units that you are returning. Be sure to include the model and part number of each unit.
 - The shipping address to which Customer Service should return the repaired equipment.

- The reason for the return:
 - The equipment needs an ECO/ECN upgrade.
 - The equipment is defective.



If the equipment is defective, please tell us what you observed just before the equipment malfunctioned. Be as detailed in your description as possible.

- If there is another reason for returning the equipment, please let us know so we can determine how best to help you.
- 4 Pack the equipment in a shipping carton.
 - 5 Write the ADC Wireline Systems Division address and the RMA Number you received from Customer Service clearly on the outside of the carton and return to:

ADC Wireline Systems Division
14352 Franklin Ave.
Tustin, CA 92780-7013

Attention: **RMA (Number)**



All shipments are to be returned prepaid. ADC will not accept any collect shipments.

APPENDIX E - ABBREVIATIONS

Numerics

2B1Q: Two Binary, One Quaternary

A

ACO: Alarm Cutoff

AIS: Alarm Indicator Signal

ALMP: Alarm Pattern Option

AMI: Alternate Mark Inversion

AWG: American Wire Gauge

B

B8ZS: Bipolar with 8-zero Substitution

BER: Bit Error Rate

BPV: Bipolar Violation

BPVT: Bipolar Violation Transparency

BRG: Bridge

C

CI: Customer Interface

CLEI: Common Language Equipment Identifier

CLOC: Customer Local Loopback

CO: Central Office

CRC: Cyclical Redundancy Check

CREM: Customer Remote Loopback

CSA: Carrier Service Area

CSU: Channel Service Unit

D

DDS: Digital Data Service

DLC: Digital Loop Carrier

DSO: Digital Signal, level 0

DSX-1: DS1 Cross-Connect Frame

E

ECI: Equipment Catalog Item

ESD: Electrostatic Discharge

ESF: Extended SuperFrame

H

HCDS: High Capacity Digital Service

HCS: HiGain Card Shelf

HDSL: High-bit-rate Digital Subscriber Line

HDU: HiGain Doubler Unit

HG: HiGain

HMU: HiGain Management Unit

HRU: HiGain Remote Unit

I

ILR: Intelligent Line Repeater

INSL: Insertion Loss

IOR: Intelligent Office Repeater

IR: Intelligent Repeater

L

LBPV: Local Bipolar Violation

LED: Light Emitting Diode

LOS: Loss of Signal

LOSW: Loss of Sync Word

M

MAL: Margin Alarm

MNGD: Managed

N

NDU: Network Doubler Unit

NEBS: Network Equipment-Building System

NI: Network Interface

NID: Network Interface Device

NIU: Network Interface Unit

NLOC: Network Local Loopback

NMA: Network Management and Administration

NREM: Network Remote Loopback

P

PL: Payload

POTS: Plain Old Telephone Service

PWRF: Selectable Power Feed

R

RCV: Receive

RLOS: Remote Loss of Signal

S

SAIS: SmartJack Alarm Indication Signal

SF: SuperFrame

SMJK: SmartJack

SPLB: Special Loopback

STS: Span Terminating Shelf

T

TEC: Total Error Count

TLOS: Transmit Loss of Signal

U

UNFR: Unframed

X

XMT: Transmit

Z

ZBTSI: Zero-Byte Timeslot Interchange

CERTIFICATION AND WARRANTY

FCC COMPLIANCE

The HLU-319 has been tested and found to comply with the limits for a Class A digital device, pursuant to Part 15 of the FCC Rules. These limits are designed to provide reasonable protection against harmful interference when the equipment is operated in a commercial environment. This equipment generates, uses, and can radiate radio frequency energy and, if not installed and used in accordance with the instruction manual, may cause harmful interference to radio communications. Operation of this equipment in a residential area is likely to cause harmful interference in which case the user will be required to correct the interference at his own expense.

LIMITED WARRANTY

ADC DSL Systems, Incorporated (“ADC”) warrants that, for a period of sixty (60) months from the date of shipment, the hardware portion of its products will be free of material defects and faulty workmanship under normal use. ADC’s obligation, under this warranty, is limited to replacing or repairing, at ADC’s option, any such hardware product which is returned during the 60-month warranty period per ADC’s instructions and which product is confirmed by ADC not to comply with the foregoing warranty.

ADC warrants that, for a period of 90 days from the date of purchase, the software furnished with its products will operate substantially in accordance with the ADC published specifications and documentation for such software. ADC’s entire liability for software that does not comply with the foregoing warranty and is reported to ADC during the 90-day warranty period is, at ADC’s option, either (a) return of the price paid or (b) repair or replace of the software. ADC also warrants that, for a period of thirty (30) days from the date of purchase, the media on which software is stored will be free from material defects under normal use. ADC will replace defective media at no charge if it is returned to ADC during the 30-day warranty period along with proof of the date of shipment.

The transportation charges for shipment of returned products to ADC will be prepaid by the Buyer. ADC will pay transportation charges for shipment of replacement products to Buyer, unless no trouble is found (NTF), in which case the Buyer will pay transportation charges.

ADC may use reconditioned parts for such repair or replacement. This warranty *does not* apply to any product which has been repaired, worked upon, or altered by persons not authorized by ADC or in ADC’s sole judgment has been subjected to misuse, accident, fire or other casualty, or operation beyond its design range.

Repaired products have a 90-day warranty, or until the end of the original warranty period—whichever period is greater.

ADC DISCLAIMS ALL OTHER WARRANTIES, EITHER EXPRESS OR IMPLIED, INCLUDING BUT NOT LIMITED TO IMPLIED WARRANTIES OF MERCHANTABILITY AND FITNESS FOR A PARTICULAR PURPOSE, WITH RESPECT TO ITS PRODUCTS AND ANY ACCOMPANYING WRITTEN MATERIALS. FURTHER, ADC DOES NOT WARRANT THAT SOFTWARE WILL BE FREE FROM BUGS OR THAT ITS USE WILL BE UNINTERRUPTED OR REGARDING THE USE, OR THE RESULTS OF THE USE, OF THE SOFTWARE IN TERMS OF CORRECTNESS, ACCURACY, RELIABILITY OR OTHERWISE.

MODIFICATIONS

Any changes or modifications made to this device that are not expressly approved by ADC DSL Systems, Inc. voids the user’s warranty. All wiring external to the products should follow the provisions of the current edition of the National Electrical Code.

STANDARDS COMPLIANCE

The HLU-319 has been tested and verified to comply with the applicable sections of the following standards:

- GR 63-CORE - Network Equipment-Building System (NEBS) Requirements: Physical Protection
- GR 1089-CORE - Electromagnetic Compatibility and Electrical Safety
- Binational standard, UL-1950/CSA-C22.2 No. 950-95: Safety of Information Technology Equipment

For technical assistance, refer to “Appendix D - Service and Support” on page 61.

ADC DSL Systems, Inc.

14402 Franklin Avenue
Tustin, CA 92780-7013

Tel: 714.832.9922

Fax: 714.832.9924

Technical Assistance

800.638.0031

714.730.3222

Document Catalog Number
LTPH-TP-1026-01, Issue 1

1148670

