

# PG-PLUS

## TECHNICAL PRACTICE

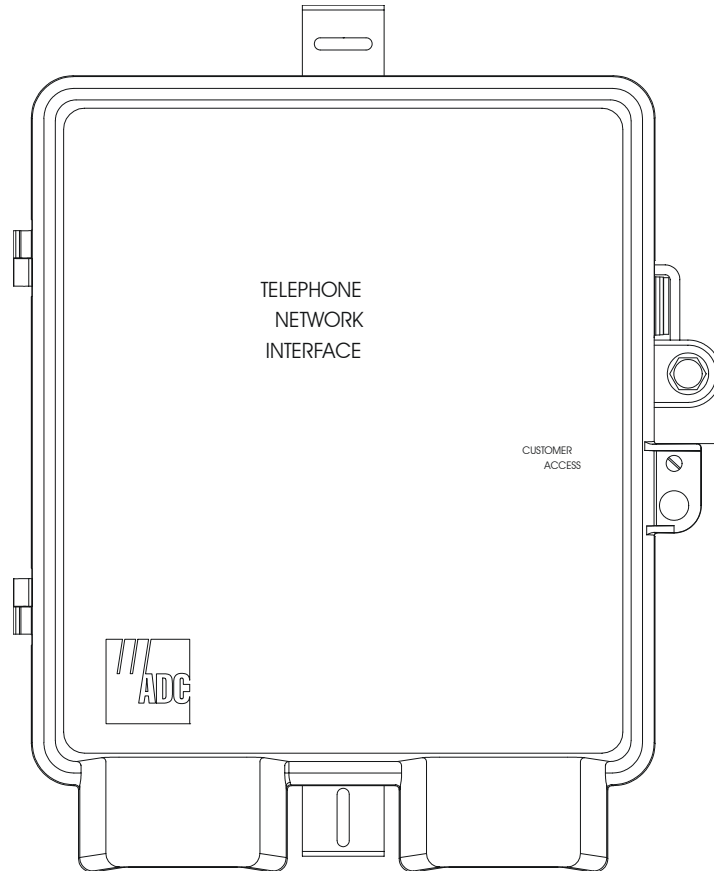

### REMOTE LINE UNIT

Model	List	CLEI Code
PRL-771	1B	S9MSBB0A~~



**Revision History of This Practice**

---

<b>Revision</b>	<b>Release Date</b>	<b>Revisions Made</b>
01	October 1, 1997	Release to change: 1 Corrected Figures. 2 Changed FCC Class.
02	December 31, 2001	Release to rebrand document to comply with ADC standards
03	January 6, 2003	Updated Product Support Information

---

**©Copyright 2003 ADC DSL Systems, Inc. All Rights Reserved.**

*ADC is a registered trademark of ADC Telecommunications, Inc. PG-Flex<sup>Plus</sup> is a registered trademark of ADC DSL Systems, Inc. No right, license, or interest to such trademarks is granted hereunder, and you agree that you shall assert no such right, license, or interest with respect to such trademarks. Other product names mentioned in this document are used for identification purposes only and may be trademarks or registered trademarks of their respective companies.*

*Information contained in this document is company private to ADC DSL Systems, Inc., and shall not be modified, used, copied, reproduced or disclosed in whole or in part without the written consent of ADC.*

*Contents herein are current as of the date of publication. ADC reserves the right to change specifications at any time without notice. Information furnished by ADC is believed to be accurate and reliable. In no event shall ADC be liable for any damages resulting from the loss of data, loss of use, or loss of profits and ADC further disclaims any and all liability for indirect, incidental, special, consequential or other similar damages. This disclaimer of liability applies to all products, publications and services during and after the warranty period.*

## USING THIS PRACTICE

Three types of messages, identified by icons, appear in the text.



**Notes indicate information about special circumstances.**



**Cautions indicate the possibility of equipment damage or the possibility of personal injury.**



**Electrostatic Discharge (ESD) susceptibility symbols indicate that a device or assembly is susceptible to damage from electrostatic discharge. You must wear an antistatic wrist strap connected to the appropriate ground connection prior to performing installation procedures. You must also observe normal ESD precautions when handling electronic equipment. Do not hold electronic plugs by their edges. Do not touch components or circuitry.**

## INSPECTING YOUR SHIPMENT

Upon receipt of the equipment:

- Unpack each container and visually inspect the contents for signs of damage. If the equipment has been damaged in transit, immediately report the extent of damage to the transportation company and to ADC. Order replacement equipment, if necessary.
- Check the packing list to ensure complete and accurate shipment of each listed item. If the shipment is short or irregular, contact ADC as described in [“Returns” on page 15](#). If you must store the equipment for a prolonged period, store the equipment in its original container.

## TABLE OF CONTENTS

<b>PRL-771 Overview</b>	<b>1</b>
Description and Features .....	1
Metallic Fallback .....	1
Specifications.....	2
Required Tools and Test Equipment .....	3
Installing the RLU .....	3
Safety Precautions .....	3
Reference Label.....	6
Install the RT Enclosure .....	7
Wiring.....	7
Attach the Frame-Ground Wire .....	8
Attach the POTS Drops .....	11
Close the Housing.....	14
Fault Isolation .....	14
<b>Product Support</b>	<b>15</b>
Technical Support .....	15
Limited Warranty.....	15
Returns .....	15
FCC Class B Compliance .....	17
Modifications .....	17
Acronyms .....	18



## LIST OF FIGURES

1. Typical PG-Plus System.....	1
2. Securing the Customer Access Door.....	4
3. Securing a Line Module .....	5
4. Reference Label.....	6
5. Installing the RT Enclosure.....	7
6. Opening the Telco Access Door.....	8
7. Attaching the Frame-Ground Wire.....	9
8. Attaching the HDSL Tip and Ring Wires .....	10
9. Inserting the POTS Wires.....	11
10. Attaching the POTS Wire Pair .....	12
11. Unplugging the RJ-11 Jack .....	13
12. Status Window.....	14





# PRL-771 OVERVIEW

This practice describes the ADC PG-Plus PRL-771 List 1B, a Remote Terminal (RT) enclosure that houses one Remote Line Unit (RLU) and provides interfaces for up to six Plain Old Telephone Service (POTS) subscribers.

## DESCRIPTION AND FEATURES

A ADC PG-Plus system provides bidirectional transport of multiple DS0s over a single, unconditioned wire pair using High-bit-rate Digital Subscriber Line (HDSL) technology. Using existing cable, PG-Plus provides for higher bandwidth needs of residential and business customers by providing multiple POTS interfaces on a single HDSL twisted-pair wire. Figure 1 shows a minimally configured ADC PG-Plus system that consists of:

- One Central Office Terminal (COTS) shelf
- One Central Office Line Unit (COLU)
- One RLU housed in an RT

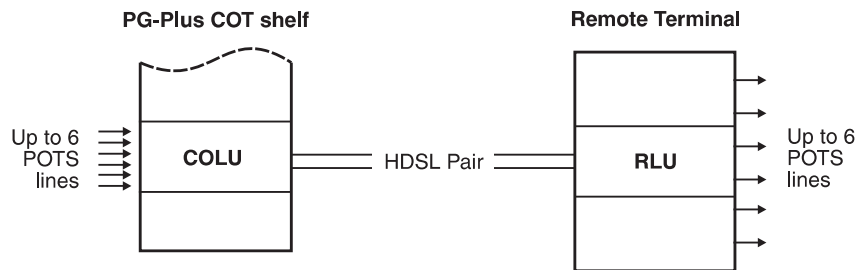

**Figure 1.** Typical PG-Plus System

Each COLU housed in a COT shelf interfaces with a corresponding RT. POTS or digital lines from a Central Office (CO) switching system connect to the COTS and are sent by means of the COLU and the HDSL wire pair to an RT. As an example, a 23-inch COTS can interface with sixteen different PRL-771 RTs providing six POTS lines each, for a total of 96 subscriber lines. The COTS operates on standard -48 V dc CO battery and supplies power to the RT, eliminating the need and expense of providing local power. A PG-Plus system with HDSL transmission and line powered RTs therefore results in fast, cost-effective solutions to POTS deployment over minimal copper facilities.

## METALLIC FALLBACK

Metallic fallback provides a direct connection from the CO to one subscriber under fault conditions. Service is provided to the subscriber assigned to the POTS line in the affected COLU. At the RLU, the system exits metallic fallback and attempts to synchronize if either POTS or the HDSL Tip to Ring pair is shorted for at least three seconds, and then released for at least three seconds. Otherwise, the COLU checks for the presence of an RLU every five minutes. If an RLU is present, the system begins HDSL synchronization acquisition.

Relays in the COLU and RLU under control of the PG-Plus PAU provide a path for Subscriber Drop Testing (SDT) and metallic fallback operation. These relays are used to establish a circuit to POTS # 1 during fault conditions and to provide for drop testing of the selected subscriber line from the CO location.

## SPECIFICATIONS

### Power

HDSL Line Operating Input Voltage	$\pm 135$ V dc (Tip to Ring, minimum)
HDSL Line Start-up Voltage	200 V dc (Tip to Ring, minimum)
PRL-771 Input Power	12.5 Watts (Tip to Ring, maximum)

### HDSL

Line Code	2B1Q
Line Rate	196 K symbols/sec (392 K b/sec); 261.3 Kb/sec
Reach	12.5 kft, 26 gauge; 18.0 kft, 24 gauge; 25.2 kft, 22 gauge

### Environment

Temperature	-40°F to +149°F; -40°C to + 65°C
Humidity	5% to 95% (non-condensing)
Altitude	-200 ft. MSL to 13,000 ft. MSL; -60 m MSL to 4,000 m MSL
Vibration	NEBS
Electrostatic Discharge	Per GR-1089-CORE
Power and Lightning	Per GR-1089-CORE
Human Safety	Per UL 1459
Emissions Radiation and Immunity	Per FCC Part 15 for Class A digital devices

### POTS Interface

Analog Impedance	600 $\Omega$
PRL supervisory range	100 $\Omega$ plus 430 $\Omega$ for handset
Detection of Loop Open	$\geq 10$ k $\Omega$
Idle State Voltage	-48 V minimum
Loop Current	23 mA minimum
Ring Generation	Balanced, Trapezoidal 40 Vrms minimum @ $20 \pm 3$ Hz in up to 5 REN per line (10 REN total at PRL)
Ring Trip	Removed in 200 ms after Loop Closure

### Connectors

HDSL	3-terminal station protector, 3/8-inch hex nut
POTS	Screw Terminals on RJ-11 line interface

### Dimensions

Height	10.25 in. (26.0 cm.)
Width	8.5 in. (21.6 cm.)
Depth	4.75 in. (12.1 cm.)
Weight	4 lbs. (1.81 kg.)

## INSTALLATION AND TEST

---

### REQUIRED TOOLS AND TEST EQUIPMENT

The tools and test equipment required for the RLU are:

- One Telephone test set
- One 1/4-inch flat-head screwdriver
- One #1 Phillips screwdriver
- One insulated-handle 3/8-inch nut driver
- One 5/32-inch hex key, drilled for tamper-proof fasteners
- One insulated-handle wire stripper
- One insulated-handle needlenose pliers
- One insulated-handle wire cutter

### INSTALLING THE RLU

#### Safety Precautions

To ensure the safety of personnel and equipment, carefully observe the following safety rules.



*Be careful when installing or modifying telephone lines. Dangerous voltages can be present. It is unsafe to install telephone wiring during a lightning storm.*

*Always disconnect all telephone lines and power connections before servicing or disassembling this equipment.*

*For performance and safety reasons, use only power supplies listed with telephone equipment by a locally recognized organization.*

*All wiring external to the product should follow the local wiring codes.*

*Always treat the HDSL pair as if it were live with high voltage present. Use caution when installing an HDSL pair that is already connected to a COLU, because dangerous voltages are present on the HDSL pair. The COLU, unless previously disabled by means of craft provisioning, periodically attempts to power up the RLU by applying  $\pm 100$  V dc with respect to ground to the HDSL pair. The COLU also initiates a start-up after a momentary short has been applied to the HDSL pair. The COLU responds with start-up voltage three seconds after removal of the short.*

## Security

You have full access to the interior of the RT and to each Line Module by loosening the Telco override screw from the Customer Access door, or by loosening the tamper-proof screw from the Telco Access door (see Figure 2). The tamper-proof screw can be either of the following:

- #8 pan-head pin and socket type, which requires a 5/32-inch drilled hex key. The #8 pan-head pin and socket type screw is preferred for improved security.
- 3/8-inch hex-head screw, which requires a 3/8-inch nut driver (216 tool or can wrench).

In either case, to gain access to the interior of the RT and to each Line Module, use a 5/32-inch drilled hex key to loosen and then remove the Telco override screw from the Customer Access or Telco Access door.

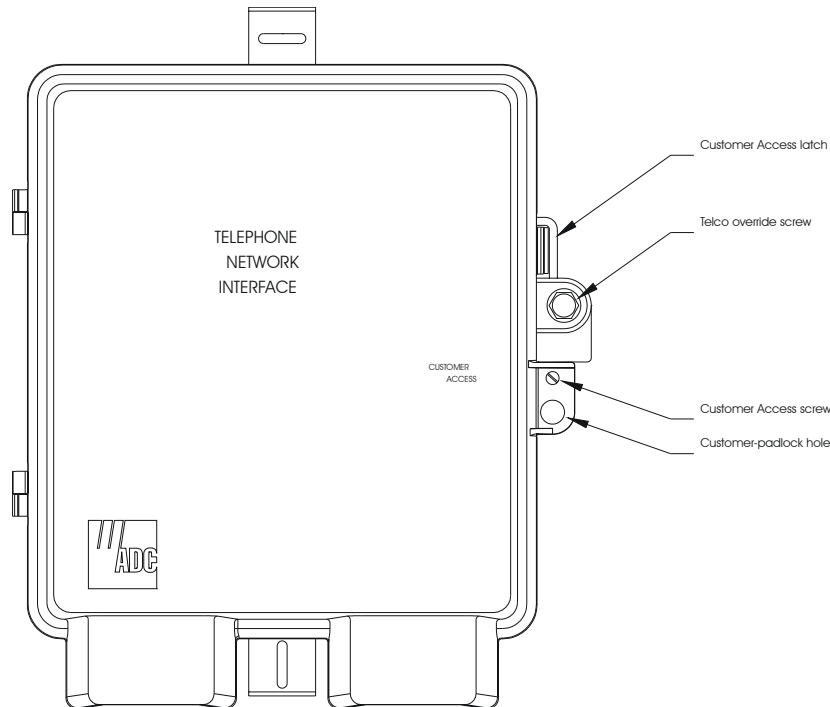

**Figure 2.** *Securing the Customer Access Door*

Subscribers can place a padlock through the customer-padlock hole drilled into the Customer Access door hasp to secure the Customer Access door.

For installations where more than one subscriber is serviced out of a single RT unit, you should plug the customer-padlock hole in the Customer Access door hasp with a 3/8-inch diameter hole plug. When more than one subscriber is serviced out of a single RT, the subscriber can protect his line against unauthorized use by placing a padlock through the latch on the appropriate Line Module door (Figure 3).

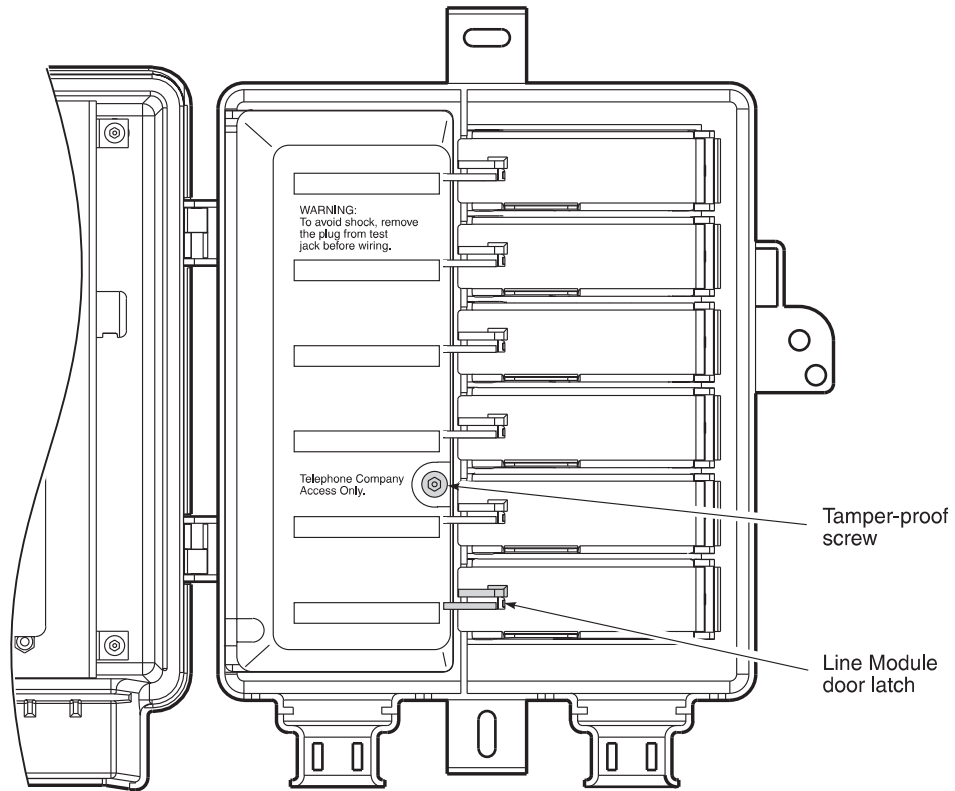

**Figure 3.** Securing a Line Module

### Reference Label

During installation, refer to the RLU reference label (see Figure 4) affixed inside the Customer Access door. The middle section of the RLU reference label identifies the Frame Ground and HDSL Tip and Ring wires as well as the wire color code for the six POTS lines.

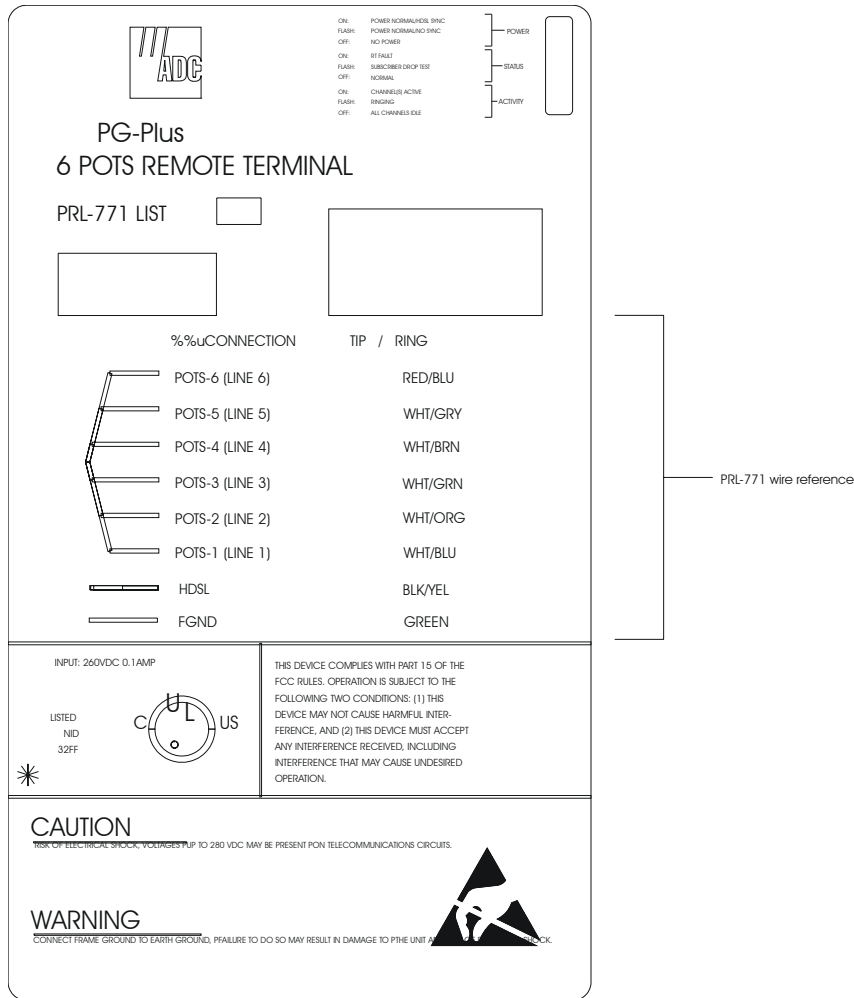

**Figure 4.** Reference Label

## Install the RT Enclosure



Install the RT enclosure only as shown in Figure 4, with all access openings facing down. Otherwise, possibly damaging materials (such as fluids) can enter the RT enclosure.

Use the two #10 x 1.5-inch wood screws and flat washers provided in the Mounting Kit to attach the RT enclosure to the side of the customer residence (see Figure 5). For installation on stucco or other suitable surface, use the two ADC provided #10 x 1-inch anchor nuts.

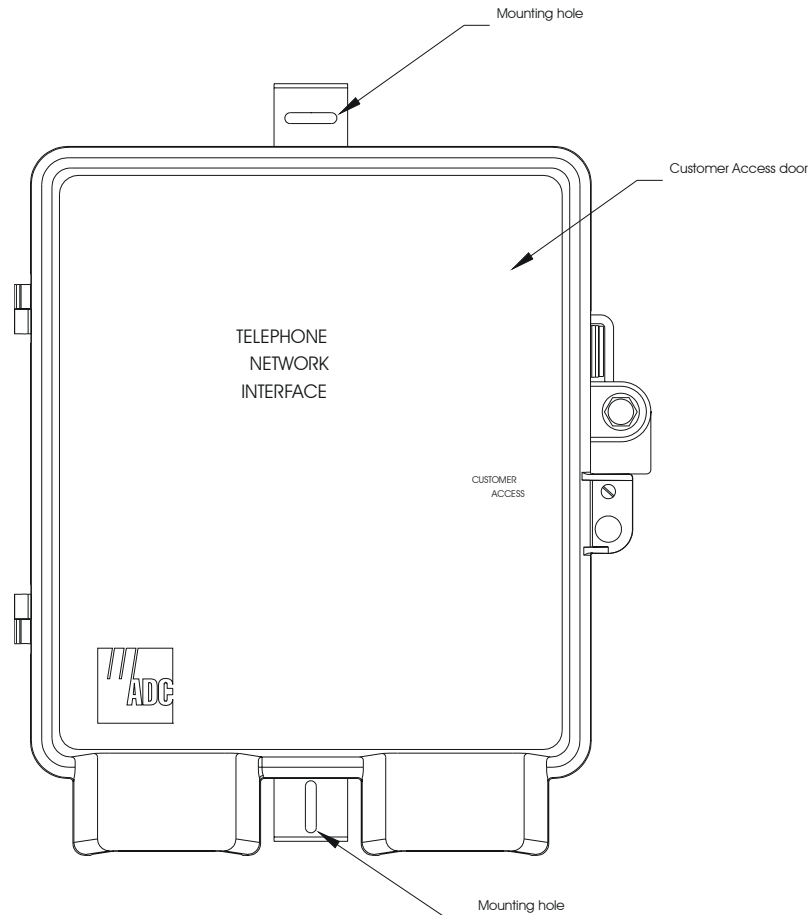

**Figure 5.** Installing the RT Enclosure

## Wiring

A wiring harness, consisting of a cable for the three POTS and one ISDN pairs, a cable for the HDSL pair, and a frame ground wire, is held with a strain relief as it exits the inner metal case. The wiring harness is factory wired to the primary protection devices for the ISDN and HDSL pairs and to the frame ground bus. An additional frame ground is attached to the metal case. The Line Modules on the ISDN and POTS lines provide an RJ-11 test jack for isolating trouble to the network or subscriber. Each ISDN and POTS line is protected by a gas tube over-voltage protection device under the Telco cover.

HDSL and subscriber wiring are threaded through rubber grommets at the bottom of the enclosure. The HDSL pair from the COTS is terminated on an over-voltage-protected threaded binding post at the bottom of the enclosure and connected to the HDSL pair in the wiring harness. Subscriber line connections are made through the right-hand side of the Line Modules. An RJ-11 jack allows the subscriber line to be disconnected from the network, or allows for an ISDN test set to be plugged in as an aide to diagnostic tests.

### Attach the Frame-Ground Wire

To attach the ground wire:

- 1 Use a 5/32-inch tamper-proof hex key to loosen the tamper-proof screw on the Telco Access door, then open the Telco Access door (Figure 6)

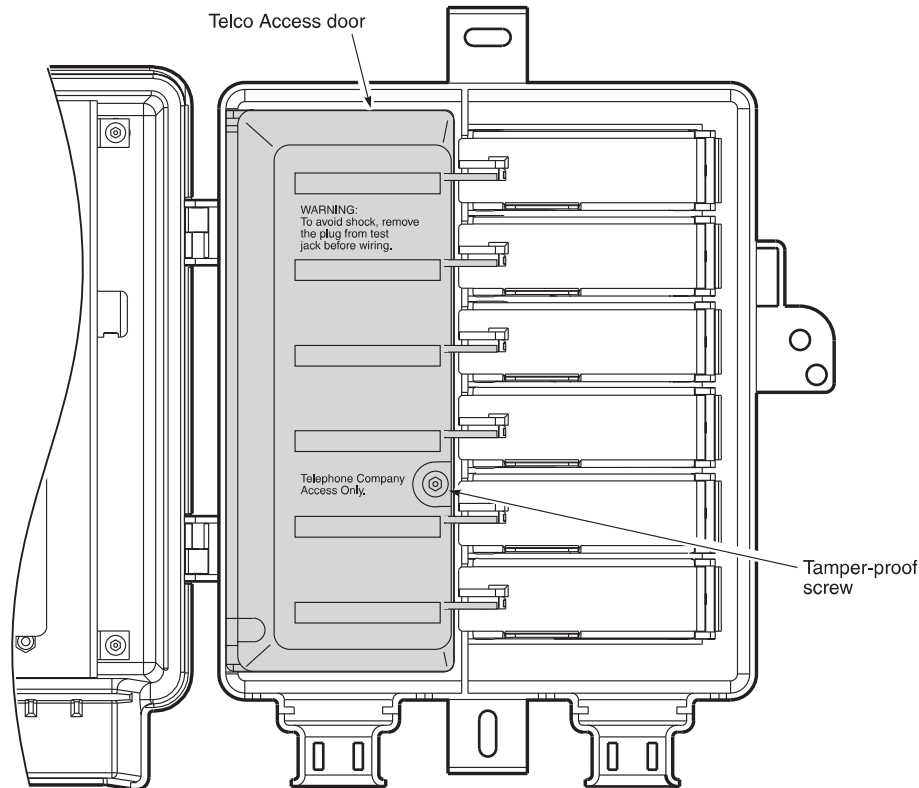

**Figure 6.** Opening the Telco Access Door

- 2 Use a #1 Phillipshead screwdriver to punch a small hole in the bottom of the rubber grommet on the left-hand bottom side of the RT enclosure (see Figure 7).



*Cutting the grommet with a utility knife or something similar is not recommended, because this may cause a large opening in the grommet, allowing insects or other contaminants to enter the enclosure.*

- 3 Insert the frame-ground wire into the RT enclosure through the hole made in step 1. A 10 AWG copper frame ground wire is recommended.
- 4 Loosen and remove from the ground-binding post the top nut and three flat washers.



- 5 Loop the frame-ground wire around the ground-binding post.
- 6 Replace in reverse order and tighten the hardware removed in step 4.

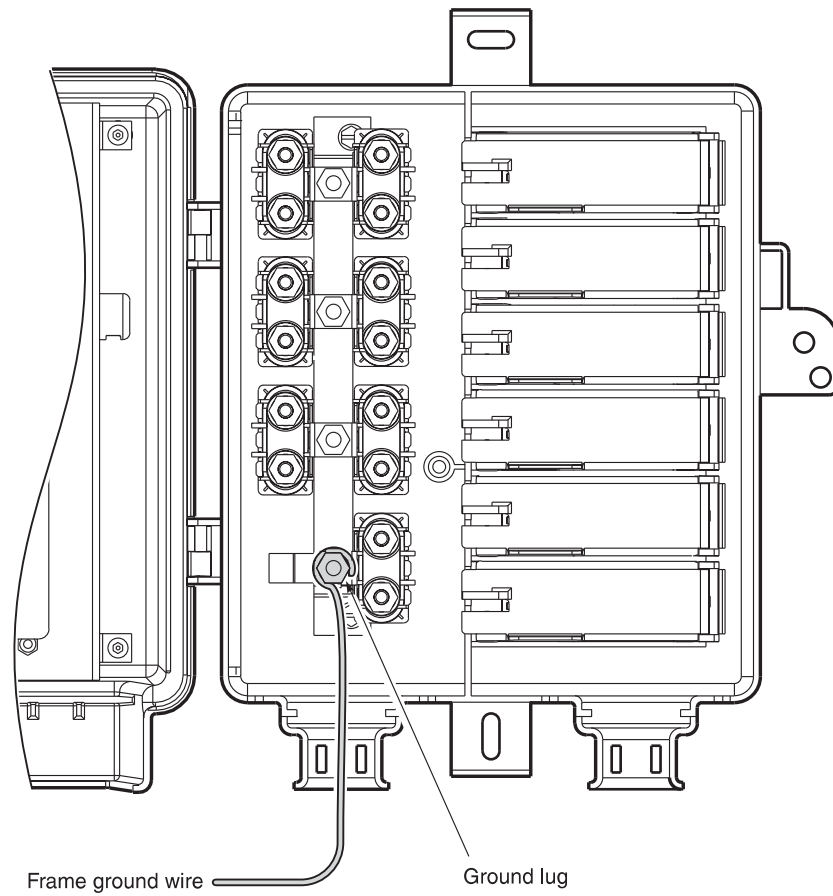

**Figure 7.** Attaching the Frame-Ground Wire

## Attach the HDSL Tip and Ring Wires

To attach the Tip and Ring wires:



*Always treat the HDSL pair as if it were live with high voltage present. Review the safety precautions at the beginning of this section before proceeding.*

- 1 Use a #1 Phillipshead screwdriver to punch a second small hole in the bottom of the rubber grommet on the left-hand bottom side of the RT enclosure (see Figure 8).



*Cutting the grommet with a utility knife or something similar is not recommended, because this may cause a large opening in the grommet, allowing insects or other contaminants to enter the enclosure.*

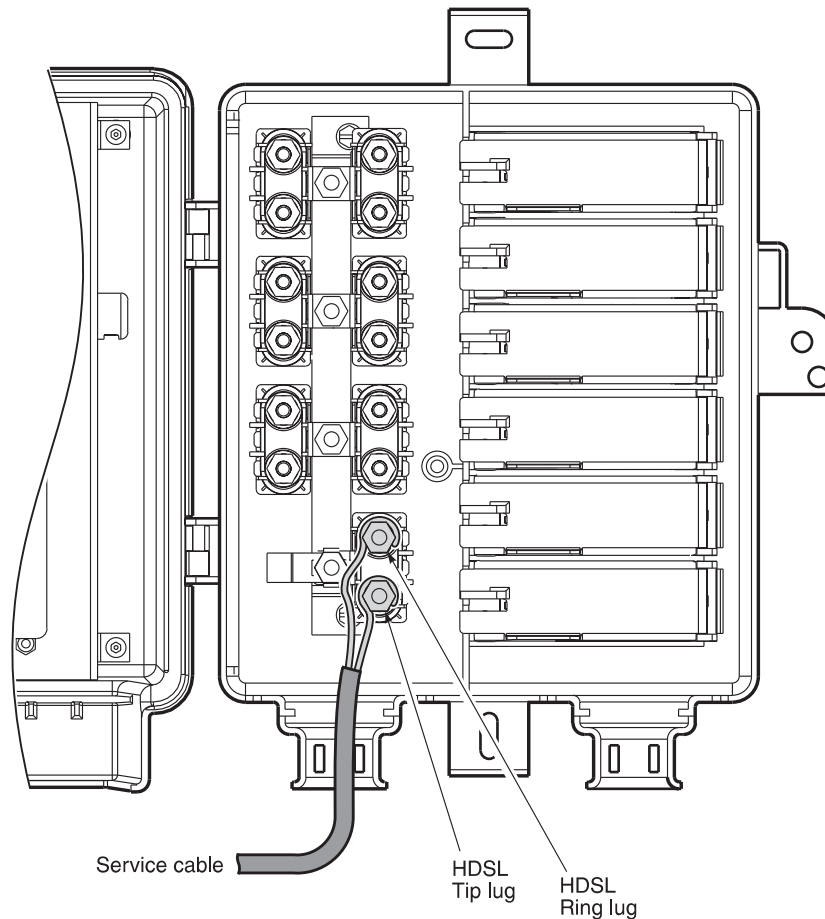

**Figure 8.** Attaching the HDSL Tip and Ring Wires

- 2 Insert the service cable containing the HDSL Tip and Ring wires into the hole made in step 1.
- 3 Loosen only the top nut on the Tip and Ring gas tube protection binding posts (see Figure 8).



*If this unit is to be pole mounted, ADC recommends that the subscriber drop wires be connected directly to the appropriate gas tube protection binding posts.*

- 4 Remove the service cable outer jacket from the cable inside the RT enclosure.
- 5 Strip the insulation from the end of the HDSL Ring wire using an insulated handle wire stripper.
- 6 Carefully insert and loop in a clockwise direction the HDSL Ring wire between the top two washers on the HDSL binding post. To avoid electrical shock, handle the stripped HDSL wire by its insulation with insulated-handle needlenose pliers.
- 7 Tighten the HDSL binding post nut with an insulated-handle nut driver.
- 8 Trim any excess uninsulated wire with an insulated-handle wire cutter.
- 9 Repeat steps 6, 7, and 8 for connecting the HDSL Tip wire to its gas tube protection binding post.

#### Attach the POTS Drops

To attach the POTS drops:

- 1 Use a #1 Phillips screwdriver to punch a second small hole in the bottom of the rubber grommet on the right-hand bottom side of the RT enclosure (see Figure 9).



*Cutting the grommet with a utility knife or something similar is not recommended, because this may cause a large opening in the grommet that would allow insects or other contaminants to enter the enclosure.*

- 2 Lift the appropriate Line Module door (see Figure 9)

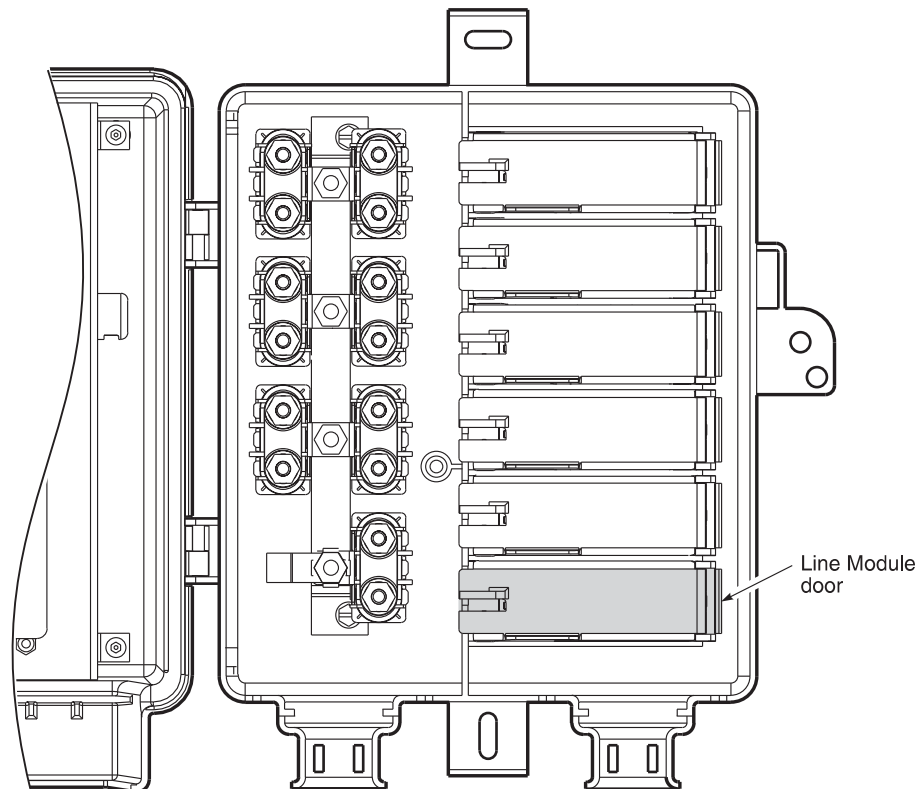

**Figure 9.** Inserting the POTS Wires

- 3 Insert the POTS wire pair through the cutout on the right side of the Line Module (Figure 10).
- 4 Connect the Tip conductor to the green terminal lug on the Line Module.
- 5 Connect the Ring conductor to the red terminal lug on the Line Module

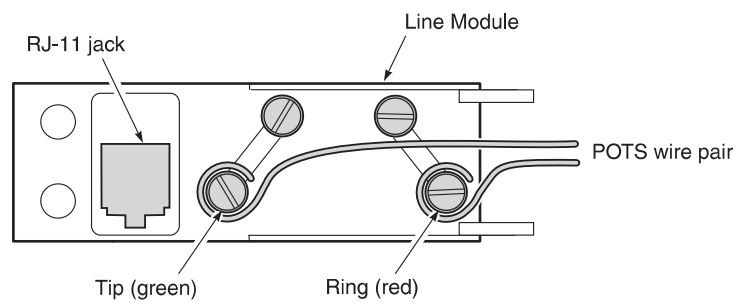
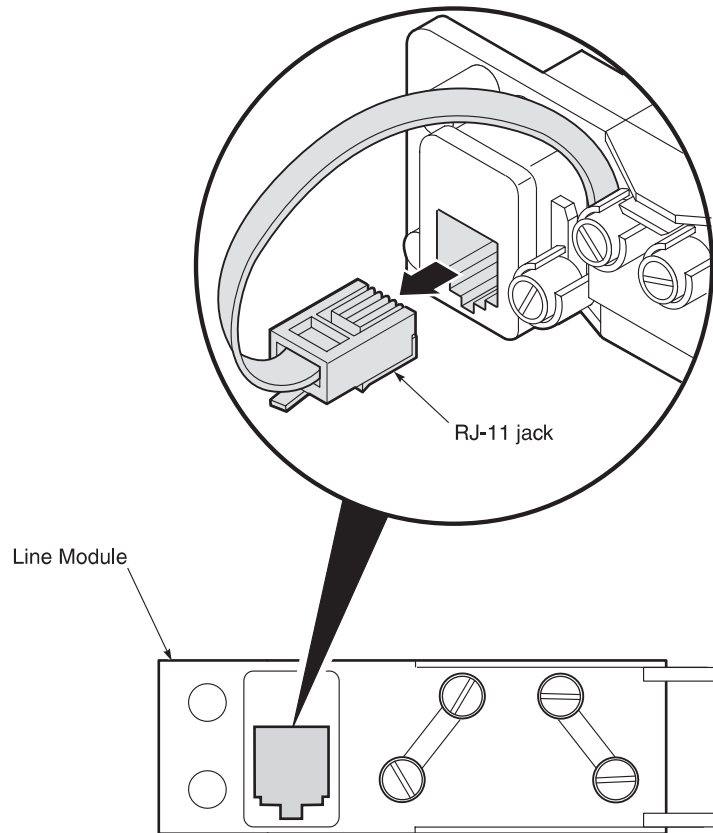

**Figure 10.** Attaching the POTS Wire Pair

## TURN UP AND TESTING

To turn-up and test the Pg-Plus system:

- 1 Open all the Line Module doors and unplug each RJ-11 jack to ensure there are no off-hook conditions present from the subscriber lines (see Figure 11)



**Figure 11.** Unplugging the RJ-11 Jack

- 2 Apply a short between the HDSL Tip and Ring conductors for at least for ten seconds. The following start-up sequence should occur after a ten second delay:
  - COLU responds with start-up voltage immediately.
  - RLU detects HDSL line voltage, drops the metallic fallback to POTS, then initiates the HDSL start-up sequence.
  - The PWR LED flashes green and the ACTIVITY LED is solid green.
 Start-up is complete when the PWR LED is on solid green and the ACTIVITY and STATUS LEDs are both OFF.
- 3 Reconnect the RJ-11 jacks and close all the Line Module doors.
- 4 Follow standard POTS procedures to check the overall performance of the POTS channel coming in and out, including ringing, dialing, and transmission. Use the customer's telephone if possible.

## CLOSE THE HOUSING



Failure to close the Telco Access door or the RT housing cover leaves the RLU interior exposed to the environment. This shortens the life span of the RLU.

To close the housing:

- 1 Close the Line Module door.
- 2 Close the Telco Access door.
- 3 Tighten the screw on the Telco Access door until it is completely seated. This is to avoid interference with the RT enclosure cover.
- 4 Close the RT housing cover and secure both the Telco override screw and the slotted-head Customer Access screw.

## FAULT ISOLATION

The circuit board metal enclosure has a System Status window through which Status LEDs can be viewed. The Status LEDs indicate different system states such as status of power, and subscriber line activity including on-hook, off-hook, ringing, and subscriber drop test activity. The top portion of the Reference label provides a guide to what the Status LEDs indicate (see Figure 12).

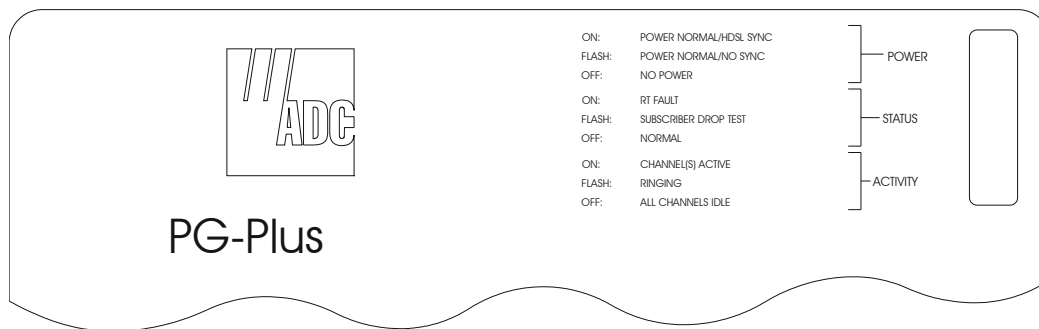

**Figure 12.** Status Window

If the RLU fails to indicate power on (as evidenced by the PWR LED being off), perform the following diagnostic and repair operations:

- 1 Verify that the RLU and its corresponding COLU are installed on the same pair.
- 2 Verify that the corresponding COLU is installed and turned up, and that the *HDSL Periodical Power Up* option is enabled.
- 3 Verify that the signal loss on the pair is no more than 41 dB at 196 kHz.
- 4 Replace the RLU.
- 5 Replace the corresponding COLU.
- 6 Check for a short placed on the HDSL Tip and Ring conductors, and remove if necessary.
- 7 Check for HDSL cable fault, and replace if necessary.

# PRODUCT SUPPORT

## TECHNICAL SUPPORT

Technical Assistance is available 24 hours a day, 7 days a week by the contacting Customer Service Engineering group at:

Telephone: 800.366.3891  
The 800 telephone support line is toll-free in the U.S. and Canada.

Email: [wsd\\_support@adc.com](mailto:wsd_support@adc.com)

Knowledge Base: [http://adc.com/Knowledge\\_Base/index.jsp](http://adc.com/Knowledge_Base/index.jsp)

Web: [www.adc.com](http://www.adc.com)

## LIMITED WARRANTY

Product warranty is determined by your service agreement. Refer to the ADC Warranty/Software Handbook for additional information, or contact your sales representative or Customer Service for details.

## RETURNS

To return equipment to ADC:

- 1 Locate the number of the purchase order under which the equipment was purchased. To obtain a return authorization number, you need to provide the original purchase order number to ADC's Return Material Authorization (RMA) Department.
- 2 Call or write ADC's RMA Department to ask for an RMA number and any additional instructions. Use the telephone number, fax number or email address listed below:
  - Telephone: 800.366.3891
  - Email Address: [rma@ADC.com](mailto:rma@ADC.com)
- 3 Include the following information, in writing, along with the equipment you are returning:
  - Company name and address.
  - Contact name and telephone number.
  - The shipping address to which ADC should return the repaired equipment.
  - The original purchase order number.
  - A description of the equipment that includes the model and part number of each unit being returned, as well as the number of units that you are returning.
  - The reason for the return. For example:
    - The equipment needs an ECO/ECN upgrade.
    - The equipment is defective.



**If the equipment is defective, please tell us what you observed just before the equipment malfunctioned. Be as detailed in your description as possible.**

If there is another reason for returning the equipment, please let us know so we can determine how best to help you.

- 4 Pack the equipment in a shipping carton.
- 5 Write ADC's address and the RMA Number you received from the RMA Department clearly on the outside of the carton and return to:

ADC DSL Systems, Inc.  
14352 Franklin Ave.  
Tustin, CA 92780-7013

Attention: **RMA (Number)**



**All shipments are to be returned prepaid. ADC will not accept any collect shipments.**



## FCC CLASS B COMPLIANCE

This equipment has been tested and found to comply with the limits for a Class B digital device, pursuant to part 15 of the FCC Rules. These limits are designed to provide reasonable protection against harmful interference in a residential installation. This equipment generates, uses and can radiate radio frequency energy and, if not installed and used in accordance with the instructions, may cause harmful interference to radio communications. However, there is no guarantee that interference will not occur in a particular installation. If this equipment does cause harmful interference to radio or television reception, which can be determined by turning the equipment off and on, the user is encouraged to try to correct the interference by one or more of the following measures:

- \* Reorient or relocate the receiving antenna.
- \* Increase the separation between the equipment and receiver.
- \* Connect the equipment into an outlet on a circuit different from that to which the receiver is connected.
- \* Consult the dealer or an experienced radio/TV technician for help.

## Modifications

The FCC requires the user to be notified that any changes or modifications made to this device that are not expressly approved by ADC voids the user's warranty.

All wiring external to the product(s) should follow the provisions of the current edition of the National Electrical Code.

## ACRONYMS

<b>AWG</b>	American Wire Gauge
<b>CO</b>	Central Office
<b>COLU</b>	Central Office Line Unit
<b>COTS</b>	Central Office Terminal Shelf
<b>ESD</b>	Electrostatic Discharge
<b>HDSL</b>	High-bit-rate Digital Subscriber Line
<b>LED</b>	Light-Emitting Diode
<b>MLT</b>	Mechanized Loop Test
<b>PAU</b>	PG-Plus Alarm Unit
<b>POTS</b>	Plain Old Telephone Service
<b>PRL</b>	PG-Plus Remote Line unit
<b>RLU</b>	Remote Line Unit (circuitry only)
<b>RMA</b>	Return Materials Authorization
<b>RT</b>	Remote Terminal (enclosure and RLU inclusive)
<b>SDT</b>	Subscriber Drop Test



---

**World Headquarters:**

ADC Telecommunications, Inc.  
12501 Whitewater Drive  
Minnetonka, Minnesota USA 55343

**For Technical Assistance:**

800.366.3891



1251804

---