

# PG-PLUS

## TECHNICAL PRACTICE

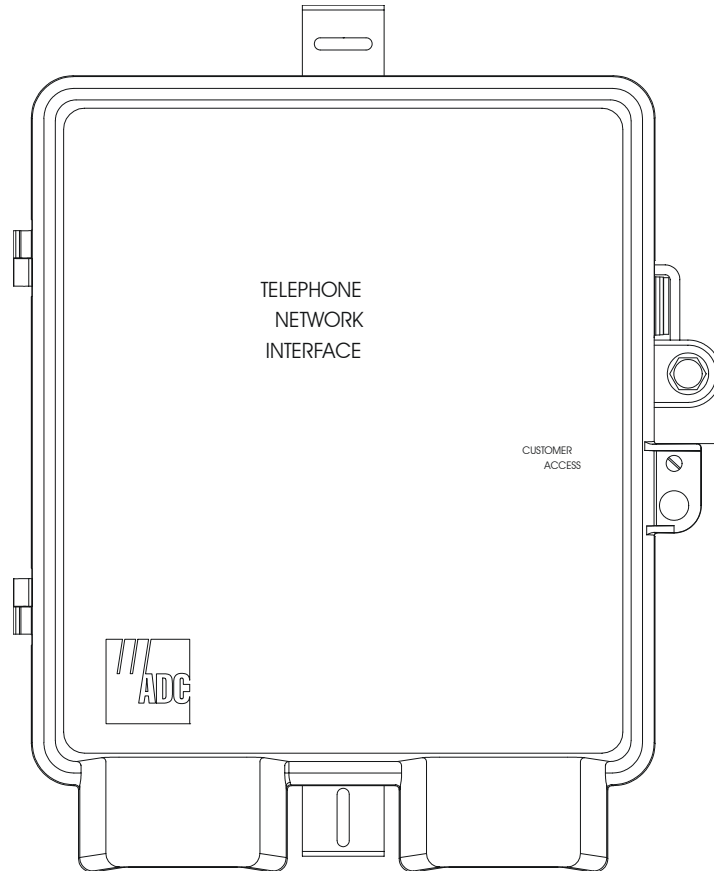

### 4 EBS

### INDOOR/OUTDOOR NID

| Model   | List | CLEI Code  |
|---------|------|------------|
| PRL-783 | 1B   | S9R1AAAA~~ |

---

**Revision History of This Practice**

---

| <b>Revision</b> | <b>Release Date</b> | <b>Revisions Made</b>                                    |
|-----------------|---------------------|--|
| 01              | December 18, 1998   | Initial Release  |
| 02              | February 1, 2002    | Release to rebrand document to comply with ADC standards |
| 03              | January 6, 2003     | Updated Product Support Information                      |

---

**©Copyright 2003 ADC DSL Systems, Inc. All Rights Reserved.**

*ADC is a registered trademark of ADC Telecommunications, Inc. PG-Plus is a registered trademark of ADC DSL Systems, Inc. No right, license, or interest to such trademarks is granted hereunder, and you agree that you shall assert no such right, license, or interest with respect to such trademarks. Other product names mentioned in this document are used for identification purposes only and may be trademarks or registered trademarks of their respective companies.*

*Information contained in this document is company private to ADC DSL Systems, Inc., and shall not be modified, used, copied, reproduced or disclosed in whole or in part without the written consent of ADC.*

*Contents herein are current as of the date of publication. ADC reserves the right to change specifications at any time without notice. Information furnished by ADC is believed to be accurate and reliable. In no event shall ADC be liable for any damages resulting from the loss of data, loss of use, or loss of profits and ADC further disclaims any and all liability for indirect, incidental, special, consequential or other similar damages. This disclaimer of liability applies to all products, publications and services during and after the warranty period.*

## USING THIS PRACTICE

Three types of messages, identified by icons, appear in the text.



**Notes indicate information about special circumstances.**



**Cautions indicate the possibility of equipment damage or the possibility of personal injury.**



**Electrostatic Discharge (ESD) susceptibility symbols indicate that a device or assembly is susceptible to damage from electrostatic discharge. You must wear an antistatic wrist strap connected to the appropriate ground connection prior to performing installation procedures. You must also observe normal ESD precautions when handling electronic equipment. Do not hold electronic plugs by their edges. Do not touch components or circuitry.**

## INSPECTING YOUR SHIPMENT

Upon receipt of the equipment:

- Unpack each container and visually inspect the contents for signs of damage. If the equipment has been damaged in transit, immediately report the extent of damage to the transportation company and to ADC. Order replacement equipment, if necessary.
- Check the packing list to ensure complete and accurate shipment of each listed item. If the shipment is short or irregular, contact ADC as described in [“Returns” on page 17](#). If you must store the equipment for a prolonged period, store the equipment in its original container.



## TABLE OF CONTENTS

|                                    |           |
|------------------------------------|-----------|
| <b>Product Overview</b>            | <b>1</b>  |
| Description and Features           | 1         |
| Specifications                     | 2         |
| <b>Installation and Test</b>       | <b>3</b>  |
| Required Tools and Test Equipment  | 3         |
| Preparing RT for Wiring            | 3         |
| Mounting the RT                    | 4         |
| Open the RT Housing                | 5         |
| Wiring the RT                      | 7         |
| Reference Label                    | 8         |
| Attach the Frame-Ground Wire       | 9         |
| Attach the HDSL Tip and Ring Wires | 10        |
| Attach the EBS Drop Wires          | 11        |
| Turn up and Testing                | 12        |
| Close the Housing                  | 13        |
| <b>Fault Isolation</b>             | <b>13</b> |
| RT Status Indicators               | 13        |
| COLU Fault Indicators              | 14        |
| Subscriber Reported Faults         | 16        |
| <b>Product Support</b>             | <b>17</b> |
| Technical Support                  | 17        |
| Limited Warranty                   | 17        |
| Returns                            | 17        |
| FCC Class B Compliance             | 19        |
| Modifications                      | 19        |
| <b>Acronyms</b>                    | <b>20</b> |



## LIST OF FIGURES

|  |    |
|--|----|
| 1. Typical PG-Plus Application.....            | 1  |
| 2. Mounting the RT .....                       | 4  |
| 3. Securing the Customer Access Door.....      | 6  |
| 4. Securing a Line Module .....                | 7  |
| 5. Reference Label.....                        | 8  |
| 6. Attaching the Frame-Ground Wire.....        | 9  |
| 7. Attaching the HDSL Tip and Ring Wires ..... | 10 |
| 8. Inserting the EBS Wires .....               | 11 |
| 9. Attaching the EBS Wire Pair.....            | 11 |
| 10. Unplugging the RJ-11 Jack .....            | 12 |
| 11. Status Window.....                         | 13 |
| 12. Troubleshooting Flowchart .....            | 16 |





# PRODUCT OVERVIEW

This practice describes the ADC® PG-Plus® PRL-783 List 1B, an RT that provides interfaces for up to four EBS subscribers.

## DESCRIPTION AND FEATURES

A PG-Plus application (see [Figure 1](#)) provides bidirectional transport of multiple DS0s over a single, unconditioned wire pair using HDSL technology. Using an existing cable, PG-Plus provides for higher bandwidth needs of residential and business customers by providing multiple EBS interfaces on a single HDSL twisted-pair wire. A typical PG-Plus application consists of:

- COTS
- COLU
- RT

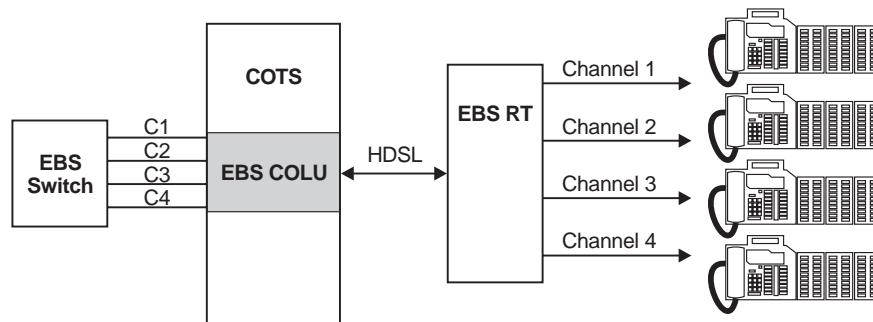

*Figure 1. Typical PG-Plus Application*

Each COLU housed in a COTS interfaces with a corresponding RT. Using one pair of 24 AWG wire, the RT can be located up to 21.7 kft from the COTS. EBS lines from a CO switching system connect to the COTS and are sent by means of the COLU and the HDSL wire pair to an RT.

The COTS operates on standard -48 Vdc CO battery and supplies power to the RT, eliminating the requirement and expense of providing local power. A PG-Plus application with HDSL transmission and line-powered RTs results in fast, cost-effective solutions to EBS deployment over minimal copper facilities.

## SPECIFICATIONS

### Power

|                            |                                      |
|----------------------------|--------------------------------------|
| HDSL Line Input Voltage    | $\pm 135$ Vdc (Tip to Ring, typical) |
| HDSL Line Start-up Voltage | 200 Vdc (Tip to Ring, minimum)       |
| PRL-783 Input Power        | 12.5 Watts (Tip to Ring, maximum)    |

### HDSL

|           |  |
|-----------|--|
| Line Code | 2B1Q   |
| Line Rate | 130.6 K symbols/sec; 261.3 Kb/sec                    |
| Reach     | 15.0 kft, 26 AWG; 21.7 kft, 24 AWG; 31.2 kft, 22 AWG |

### Environment

|                                  |   |
|----------------------------------|---|
| Temperature                      | -40°F to +149°F; -40°C to + 65°C            |
| Humidity                         | 5 percent to 95 percent noncondensing       |
| Altitude                         | -200 ft. to 13,000 ft.; -60 m to 4,000 m    |
| Vibration                        | NEBS  |
| Electrostatic Discharge          | Per GR-1089-CORE                            |
| Power and Lightning              | Per GR-1089-CORE                            |
| Human Safety                     | Per UL 1950                                 |
| Emissions Radiation and Immunity | Per FCC Part 15 for Class B digital devices |

### EBS Interface

|  |  |
|--|--|
| Analog Impedance                         | 900 $\Omega$   |
| Supported Subscriber Drop                | 200 $\Omega$ with up to 4 dB of loss @ 8 kHz for up to 38 mA phone current (low level)<br>700 $\Omega$ with up to 14 dB of loss @ 8 kHz for up to 20 mA phone current (high level) |
| Open Circuit Voltage (no phone)          | 36 Vdc Typical   |
| 8 kHz Transmit Level                     | 600 mV <sub>pp</sub> (high level); 250 mV <sub>pp</sub> (low level)  |
| 8 kHz Receive Level                      | $\geq 50$ mV <sub>pp</sub>   |
| Maximum Phone Current                    | 38 mA for 200 $\Omega$ loop, 20 mA for 700 $\Omega$ loop   |
| Minimum Phone Detection Current          | 4.5 mA   |
| Voice Transmission Loss (each direction) | 4 dB $\pm 2$ dB  |

### Connectors

|      |  |
|------|--|
| HDSL | 3-terminal station protector, 3/8-inch hex nut |
| EBS  | Screw Terminals on RJ-11 line interface        |

### Dimensions

|        |                      |
|--------|----------------------|
| Height | 10.25 in. (26.0 cm.) |
| Width  | 8.5 in. (21.6 cm.)   |
| Depth  | 4.75 in. (12.1 cm.)  |
| Weight | 4.0 lbs. (1.81 kg.)  |

# INSTALLATION AND TEST

The installation of an RT involves two procedures, mounting the housing and wiring the RT. These procedures are described in the following sections.

To ensure the safety of personnel and equipment, carefully observe the following safety rules:



**Be careful when installing or modifying telephone lines. Dangerous voltages can be present. It is unsafe to install telephone wiring during a lightning storm. Always disconnect all telephone lines and power connections before servicing or disassembling this equipment.**

**All wiring external to the product should follow the local wiring codes.**

**Always treat the HDSL pair as if it were live with high voltage present. Use caution when installing an HDSL pair that is already connected to a COLU, because dangerous voltages are present on the HDSL pair.**

**The COLU, unless previously disabled by means of Craft provisioning, periodically attempts to power up the RT by applying  $\pm 100$  Vdc with respect to ground to the HDSL pair. The COLU also initiates a start-up after a momentary short has been applied to the HDSL pair. The COLU responds with start-up voltage 3 seconds after removal of the short.**

## REQUIRED TOOLS AND TEST EQUIPMENT

The tools and test equipment required for the mounting and wiring of the RT are as follow:

- EBS Telephone set
- 1/4-inch flat-head screwdriver
- No. 1 Phillips screwdriver
- insulated-handle 3/8-inch nut driver
- 5/32-inch hex key, drilled for tamper-proof fasteners
- insulated-handle wire stripper
- insulated-handle needlenose pliers
- insulated-handle wire cutter

## PREPARING RT FOR WIRING

HDSL and subscriber wiring are threaded through rubber grommets at the bottom of the RT. Subscriber line connections are made through the right-hand side of the Line Modules. Use a No. 1 Phillips screwdriver to punch two small holes in the bottom of the rubber grommet on the left-hand bottom side and one small hole in the right-hand grommet of the RT.



**Cutting the grommet with a utility knife or something similar is not recommended, because this can cause too large an opening thus allowing contaminants to enter.**

## MOUNTING THE RT

Use the two No. 10x1.5-inch wood screws and flat washers provided in the Mounting Kit to attach the RT to the side of the customer residence (see [Figure 2](#)). For installation on stucco or other suitable surface, use the two No. 10 x 1-inch anchor nuts from the kit.



**Mount the RT only as shown in Figure 4, with all access openings facing down. Otherwise, possibly damaging materials (such as fluids) can enter the RT.**

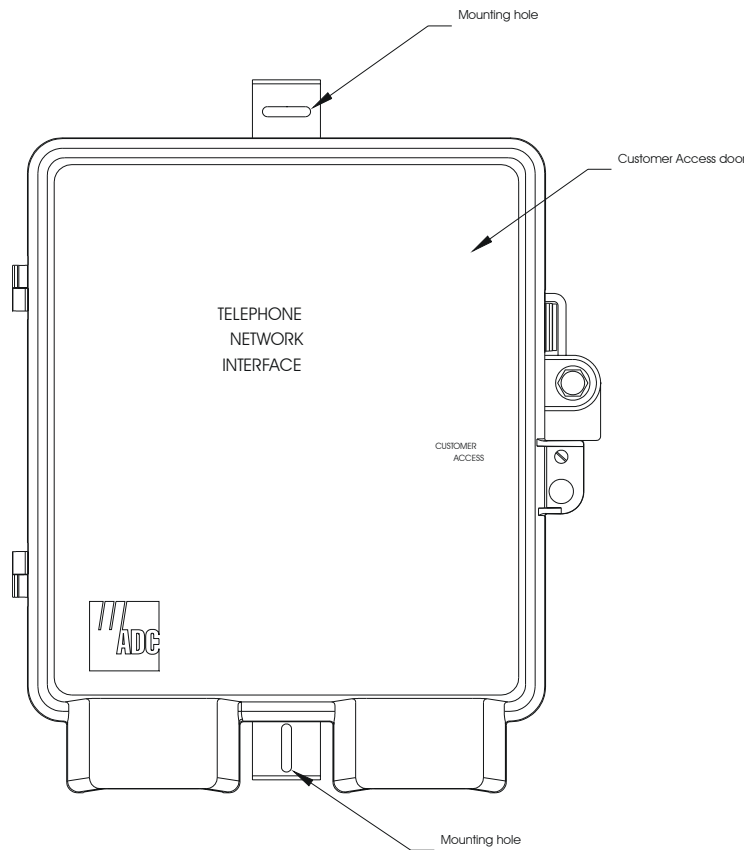

**Figure 2.** Mounting the RT

## OPEN THE RT HOUSING

You have full access to the interior of the RT and to each Line Module by loosening the Telco override screw from the Customer Access door, or by loosening the tamper-proof screw from the Telco Access door. The tamper-proof screw can be either of the following:

- No. 8 pan-head pin and socket type, which requires a 5/32-inch drilled hex key. The No. 8 pan-head pin and socket type screw is preferred for improved security.
- 3/8-inch hex-head screw, which requires a 3/8-inch nut driver (216 tool or can wrench).

In either case, to gain access to the interior of the RT and to each Line Module, use a 5/32-inch drilled hex key to loosen and then remove the Telco override screw from the Customer Access or Telco Access door.

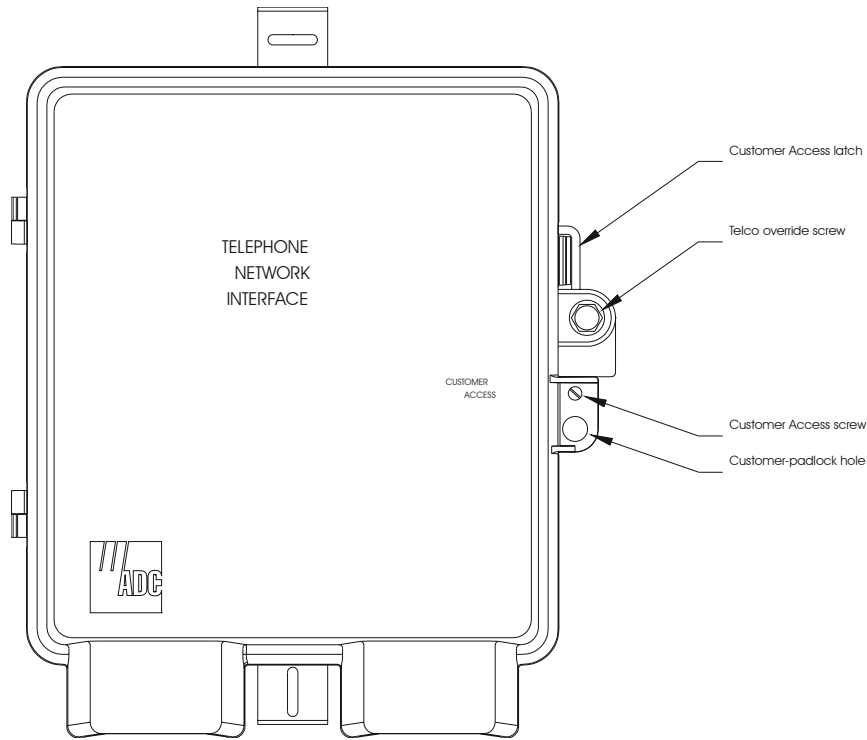

**Figure 3.** *Securing the Customer Access Door*

For installations that service more than one subscriber from a single RT, plug the customer-padlock hole in the Customer Access door hasp with a 3/8-inch diameter hole plug (see [Figure 3](#)).

Subscribers can place a padlock through the customer-padlock hole drilled into the Customer Access door hasp to secure the Customer Access door (see [Figure 4](#)).

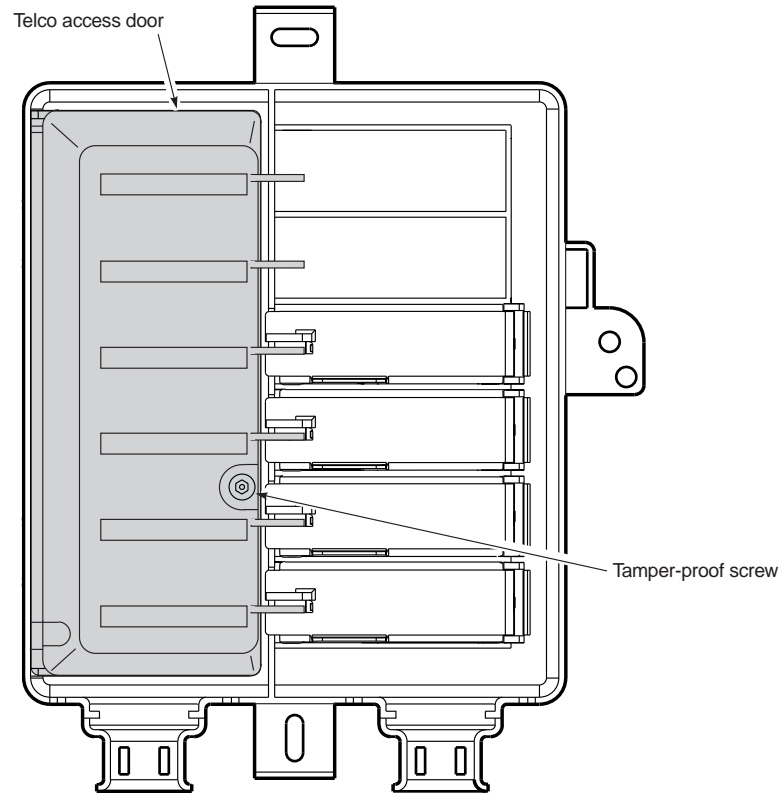

**Figure 4.** *Securing a Line Module*

## WIRING THE RT

A wiring harness, consisting of a cable for the four EBS pairs, a cable for the HDSL pair, and a frame ground wire, is held with a strain relief as it exits the inner metal frame. The wiring harness is factory-wired to the primary protection devices for the EBS and HDSL pairs and to the FGND bus. An additional frame ground is attached to the inner metal frame. The Line Modules on the EBS lines provide an RJ-11 test jack for isolating trouble to the network or subscriber. Each EBS line is protected by an over-voltage-protected threaded binding post under the Telco cover.

HDSL and subscriber wiring are threaded through rubber grommets at the bottom of the RT. The HDSL pair from the COTS is terminated on an over-voltage-protected threaded binding post at the bottom of the enclosure and connected to the HDSL pair in the wiring harness. Subscriber line connections are made through the right-hand side of the Line Modules. An RJ-11 jack allows the subscriber line to be disconnected from the network, or allows for an EBS test set to be plugged in as an aide to diagnostic tests.

## Reference Label

During installation, refer to the RT Reference label (see Figure 5) affixed inside the Customer Access door. The middle section of the Reference label identifies the Frame Ground and HDSL Tip and Ring wires, and the wire color code for the four lines.

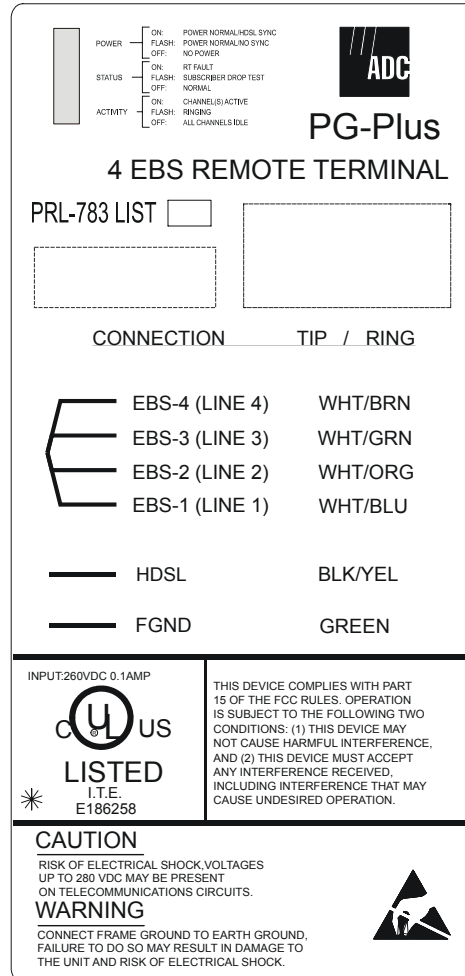
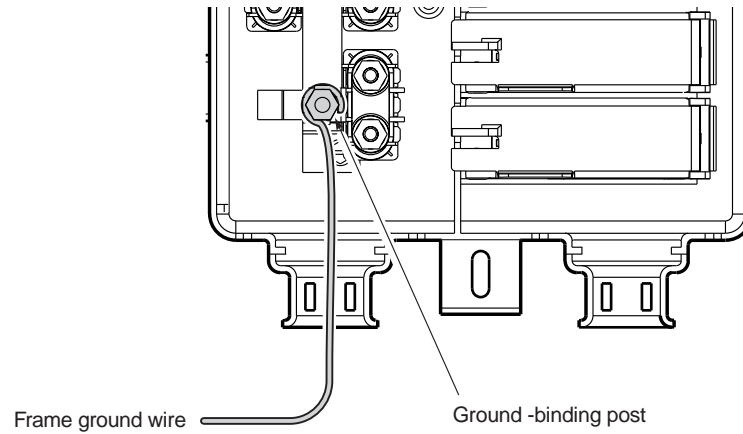

Figure 5. Reference Label



## Attach the Frame-Ground Wire

- 1 Open the Telco Access door.
- 2 Insert the FGND wire through one of the holes in the left-hand rubber grommet. A 10 AWG (25.8 mm) solid copper ground wire is recommended.



**Figure 6.** Attaching the Frame-Ground Wire

- 3 Loosen and remove the top nut and three flat washers from the ground-binding post. Loop the FGND wire around the ground-binding post. Then replace and tighten in reverse order the hardware removed earlier.

## Attach the HDSL Tip and Ring Wires



Always treat the HDSL pair as if it were live with high voltage present. Review the safety precautions at the beginning of this section before proceeding.

- 1 Insert the service cable containing the HDSL Tip and Ring wires into the second hole in the bottom of the left-hand rubber grommet.

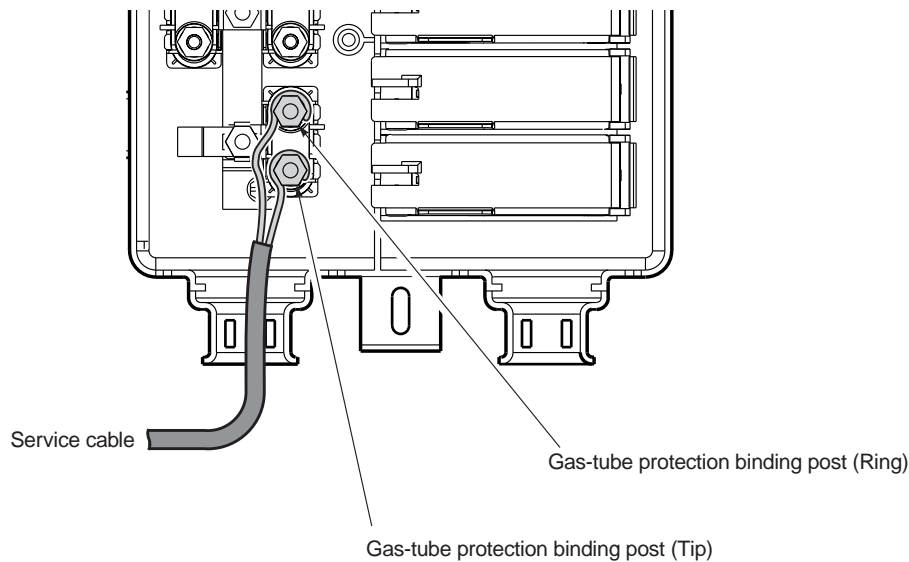

**Figure 7.** Attaching the HDSL Tip and Ring Wires

- 2 Loosen the top nuts on the Tip and Ring gas-tube protection binding posts.
- 3 Remove the service cable outer jacket from the cable inside the RT enclosure, strip the insulation from the end of the HDSL Ring wire using an insulated handle wire stripper, then carefully insert and loop the HDSL Ring wire in a clockwise direction between the top two washers on the HDSL Ring binding post.



To avoid electrical shock, handle the stripped HDSL wire by its insulation with insulated-handled needlenose pliers

- 4 Tighten the HDSL Ring binding post nut with an insulated-handle nut driver, then trim any excess uninsulated wire with an insulated-handle wire cutter.
- 5 Connect the Tip wire as done with the Ring wire in the steps above.

## Attach the EBS Drop Wires

If this unit has been pole mounted, ADC recommends that the subscriber drop wires be connected directly to the appropriate gas-tube protection binding posts.

- 1 Thread the subscriber wire pairs through the hole made earlier in the right-hand rubber grommet (see [Figure 8](#)).
- 2 Lift the Line Module door, and insert the EBS wire pair through the cutout on the right side of the Line Module door. The HDSL Tip and Ring wires, which you installed in the previous section, are not shown in this graphic.

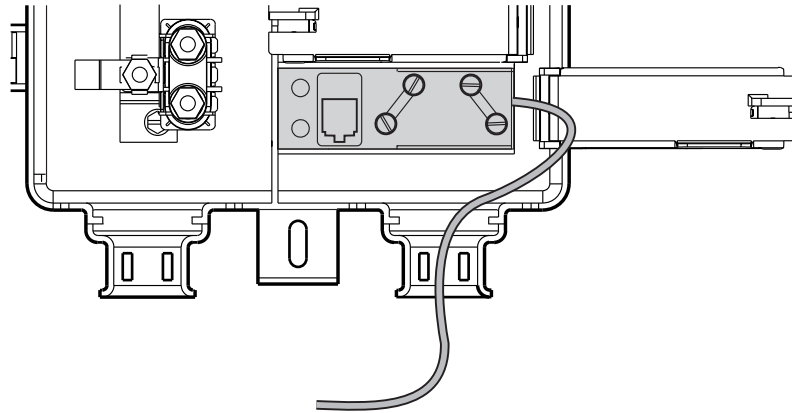

**Figure 8.** *Inserting the EBS Wires*

- 3 Connect the Tip wire to the Line Module green terminal gas-tube protection binding post, connect the Ring conductor to the red terminal gas-tube protection binding post, then close the Line Module door

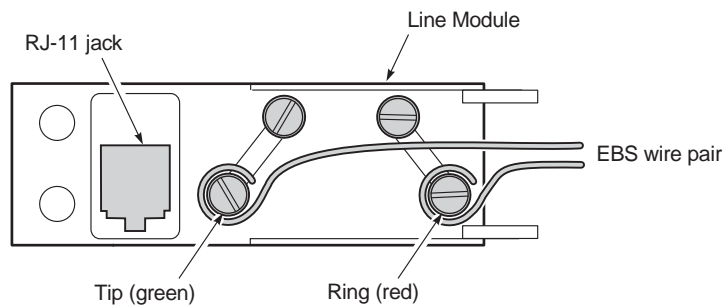

**Figure 9.** *Attaching the EBS Wire Pair*

- 4 Repeat steps 1, and 2 for each EBS line to be installed, then close the Line Module door.



**EBS pairs are Tip and Ring sensitive. If these lines are switched, the unit will not operate correctly.**

## TURN UP AND TESTING

- 1 Open all the Line Module doors and unplug each RJ-11 jack to ensure there are no wiring errors from the subscriber lines (see [Figure 10](#)).

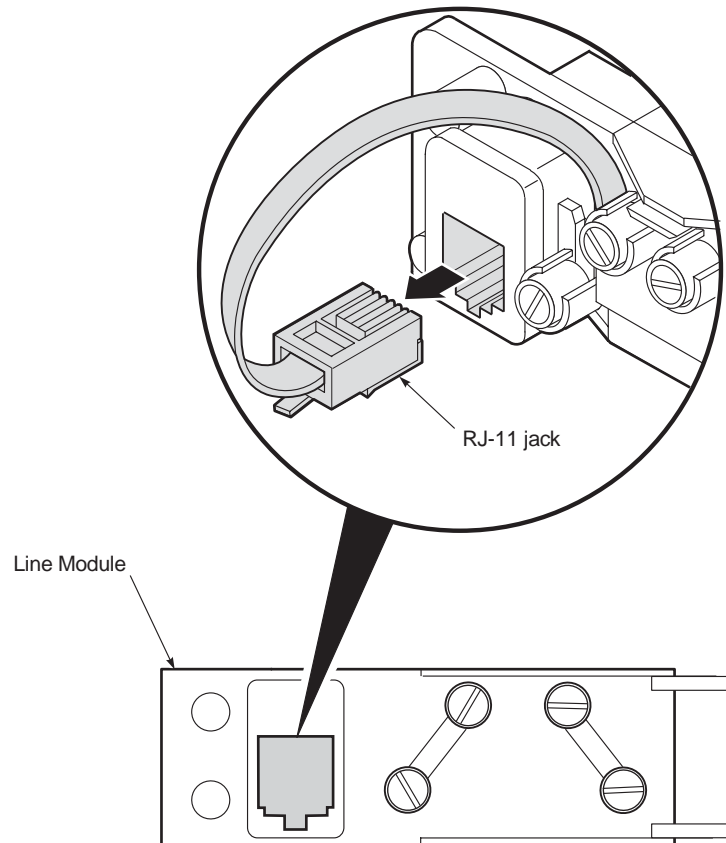

**Figure 10.** Unplugging the RJ-11 Jack

- 2 Open the Telco Access door and, at the Tip and Ring posts, apply a short between the HDSL Tip and Ring conductors there for at least 3 seconds. The following start-up sequence should occur after a 3-second delay:



**EBS pairs are Tip and Ring sensitive. If these lines are switched, the unit will not operate correctly.**

- COLU responds with start-up voltage immediately
- RT detects HDSL line voltage, then initiates the HDSL start-up sequence
- Power LED Flashes green

Start-up is complete when the Power LED is On green and the Activity and Status LEDs are Off.

- 3 Reconnect the RJ-11 jacks and close all the Line Module doors and the Telco Access door.
- 4 Follow standard EBS procedures to check the overall performance of the EBS channel coming in and out, including ringing, dialing, and transmission.

## CLOSE THE HOUSING



**Failure to close the Telco Access door or the RT housing cover leaves the RT interior exposed to the environment. This shortens the life span of the RT.**

- 1 Close the Line Module doors and the Telco Access door.
- 2 Tighten the screw on the Telco Access door until it is completely seated. This is to avoid interference with the RT enclosure cover.
- 3 Close the RT housing cover and secure both the Telco override screw and the slotted-head Customer Access screw.

## FAULT ISOLATION

The following sections detail the fault isolation procedures. For sections that indicate a condition such as “distance limitation exceeded”, refer to “[Specifications 2](#) for the correct values.

### RT STATUS INDICATORS

You can view the LEDs status through the window of the RT case. These LEDs indicate system states and subscriber line activity. The top portion of the label is a guide to the meaning of the Status LEDs (see [Figure 11](#)).

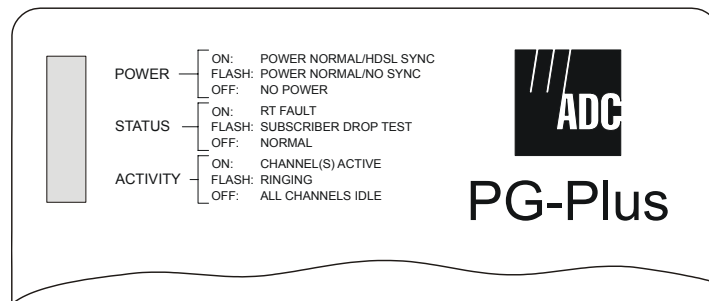

*Figure 11. Status Window*

If the PWR LED is Off, perform the following operations:

- 1 Verify that the RT and its corresponding COLU are installed on the same pair.
- 2 Verify that the COLU is installed and turned up, and that the HDSL Periodical Power Up option is Enabled.
- 3 Verify that the signal loss on the pair is no more than 41 dB at 130 kHz.
- 4 Check for a short placed on the HDSL Tip and Ring conductors, and remove if necessary.
- 5 Check for HDSL cable fault, and replace if necessary.
- 6 Replace the RT.
- 7 Replace the corresponding COLU.

## COLU FAULT INDICATORS

At the CO, you can use the VT-100 terminal to initiate a SDT to determine the cause of any of the following problems. The following sections provide procedures for isolating faults indicated by the COLU LEDs.

- No LEDs On**
- processor in the COLU stopped
    - 1 Remove and re-insert the COLU.
    - 2 At the VT-100 interface, go to the COLU Main Screen to view the Performance report to verify that no alarms exist. If you cannot view the COLU Main Screen, a communication error exists indicating a faulty COLU.
    - 3 If the LEDs do not illuminate, replace the COLU.
- Fault LED On**
- indicates an existing alarm condition on the COLU
    - 1 At the VT-100 interface, go to the COLU Main Screen to view the Performance report to determine the cause of the alarm. Correct the condition, if possible. If you cannot view the COLU Main Screen, a communication error exists.
    - 2 Remove and re-insert the COLU.
    - 3 If the communication error still exists, replace the COLU.
- Margin LED On**
- distance limitation exceeded
  - fault in HDSL line.
  - faulty COLU
    - 1 At the VT-100 interface, go to the COLU Main Screen to view the Performance report to verify that no alarms exist.
    - 2 Initial installation, check engineering records for distance between COTS and RT.
    - 3 If existing installation, measure loss of HDSL line to ensure that the maximum attenuation value has not been exceeded.
    - 4 Replace COLU and/or the RT.
- Margin LED Flashing**
- distance limitation exceeded
  - fault in HDSL line
  - faulty RT
    - 1 Initial installation, check engineering records for distance between COTS and RT.
    - 2 If existing installation, measure loss of HDSL line to ensure that the maximum attenuation value has not been exceeded.
    - 3 Replace COLU and/or the RT.
- SYNC LED Off**
- HDSL line has lost synchronization
  - distance limitation may have been exceeded
  - COLU is faulty
    - 1 Initial installation, check engineering records for distance between COTS and RT.
    - 2 If existing installation, measure loss of HDSL line to ensure that the maximum attenuation value has not been exceeded.
    - 3 Replace COLU and/or the RT.

**PWR LED Off**

- no input power
- on-board fuse is blown on COLU
  - 1 Ground fault condition exists.
  - 2 Check input power at COTS backplane with COLU removed.
  - 3 If power is present at COTS backplane, replace the COLU.

**PWR LED****Flashing**

- HDSL line open
- an overload exists
  - 1 Check line continuity and resistance.
  - 2 COLU power supply or RT may be faulty.

# SUBSCRIBER REPORTED FAULTS

At the CO, you can use the VT-100 terminal to log onto the COLU and to initiate a SDT to determine the cause of any of the following problems.

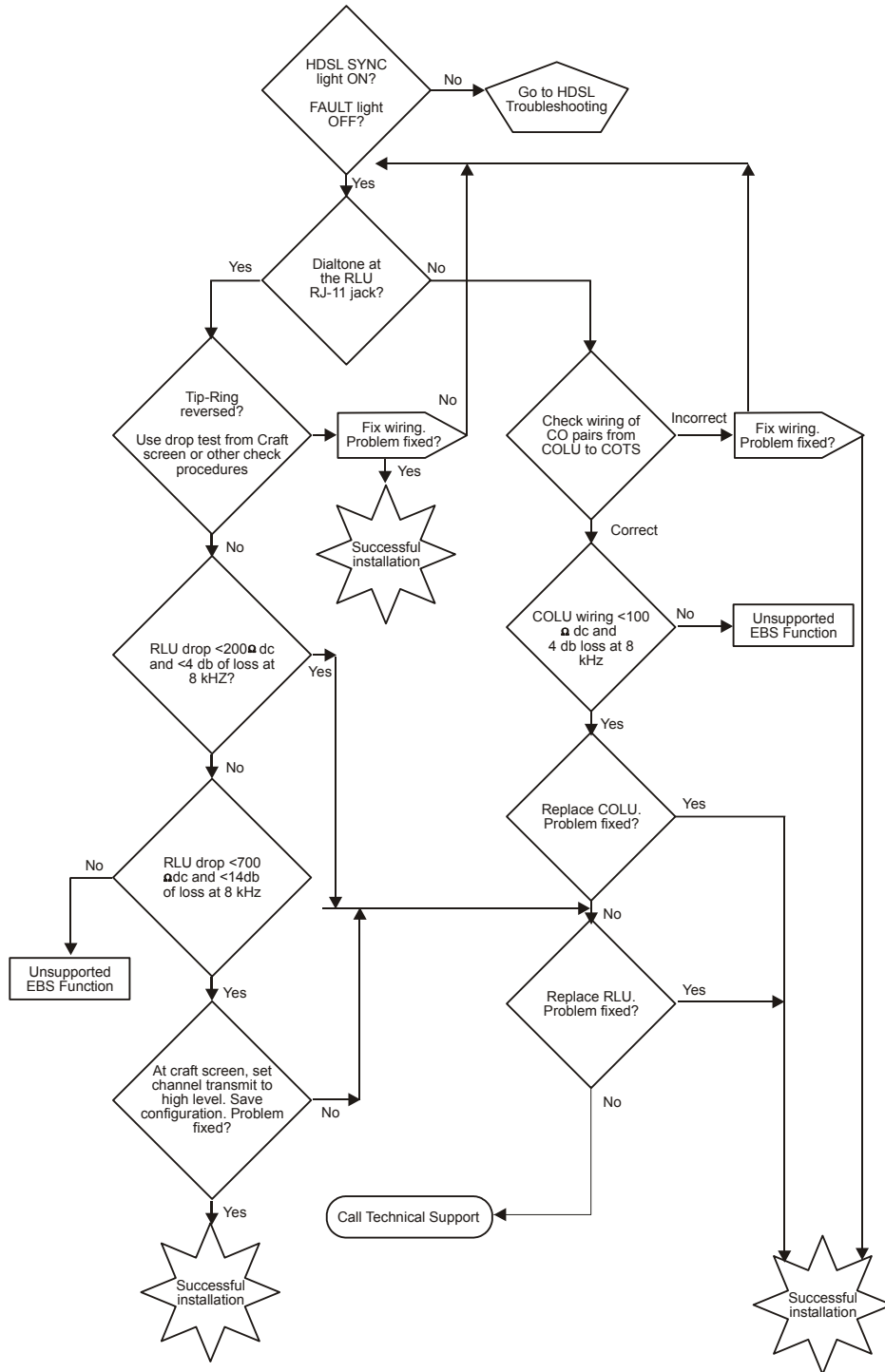

Figure 12. Troubleshooting Flowchart



# PRODUCT SUPPORT

## TECHNICAL SUPPORT

Technical Assistance is available 24 hours a day, 7 days a week by the contacting Customer Service Engineering group at:

Telephone: 800.366.3891  
The 800 telephone support line is toll-free in the U.S. and Canada.

Email: [wsd\\_support@adc.com](mailto:wsd_support@adc.com)

Knowledge Base: [http://adc.com/Knowledge\\_Base/index.jsp](http://adc.com/Knowledge_Base/index.jsp)

Web: [www.adc.com](http://www.adc.com)

## LIMITED WARRANTY

Product warranty is determined by your service agreement. Refer to the ADC Warranty/Software Handbook for additional information, or contact your sales representative or Customer Service for details.

## RETURNS

To return equipment to ADC:

- 1 Locate the number of the purchase order under which the equipment was purchased. To obtain a return authorization number, you need to provide the original purchase order number to ADC's Return Material Authorization (RMA) Department.
- 2 Call or write ADC's RMA Department to ask for an RMA number and any additional instructions. Use the telephone number, fax number or email address listed below:
  - Telephone: 800.366.3891
  - Email Address: [rma@ADC.com](mailto:rma@ADC.com)
- 3 Include the following information, in writing, along with the equipment you are returning:
  - Company name and address.
  - Contact name and telephone number.
  - The shipping address to which ADC should return the repaired equipment.
  - The original purchase order number.
  - A description of the equipment that includes the model and part number of each unit being returned, as well as the number of units that you are returning.
  - The reason for the return. For example:
    - The equipment needs an ECO/ECN upgrade.
    - The equipment is defective.



**If the equipment is defective, please tell us what you observed just before the equipment malfunctioned. Be as detailed in your description as possible.**

If there is another reason for returning the equipment, please let us know so we can determine how best to help you.

- 4 Pack the equipment in a shipping carton.
- 5 Write ADC's address and the RMA Number you received from the RMA Department clearly on the outside of the carton and return to:

ADC DSL Systems, Inc.  
14352 Franklin Ave.  
Tustin, CA 92780-7013

Attention: **RMA (Number)**



**All shipments are to be returned prepaid. ADC will not accept any collect shipments.**

## FCC CLASS B COMPLIANCE

This equipment has been tested and found to comply with the limits for a Class B digital device, pursuant to part 15 of the FCC Rules. These limits are designed to provide reasonable protection against harmful interference in a residential installation. This equipment generates, uses and can radiate radio frequency energy and, if not installed and used in accordance with the instructions, may cause harmful interference to radio communications. However, there is no guarantee that interference will not occur in a particular installation. If this equipment does cause harmful interference to radio or television reception, which can be determined by turning the equipment off and on, the user is encouraged to try to correct the interference by one or more of the following measures:

- \* Reorient or relocate the receiving antenna.
- \* Increase the separation between the equipment and receiver.
- \* Connect the equipment into an outlet on a circuit different from that to which the receiver is connected.
- \* Consult the dealer or an experienced radio/TV technician for help.

## Modifications

The FCC requires the user to be notified that any changes or modifications made to this device that are not expressly approved by ADC voids the user's warranty.

All wiring external to the product(s) should follow the provisions of the current edition of the National Electrical Code.

---

# ACRONYMS

|             |                                       |
|-------------|---------------------------------------|
| <b>AWG</b>  | American Wire Gauge                   |
| <b>CO</b>   | Central Office                        |
| <b>COLU</b> | Central Office Line Unit              |
| <b>COTS</b> | Central Office Terminal Shelf         |
| <b>EBS</b>  | Electronic Business Service           |
| <b>ESD</b>  | Electrostatic Discharge               |
| <b>HDSL</b> | High-bit-rate Digital Subscriber Line |
| <b>LED</b>  | Light-Emitting Diode                  |
| <b>MLT</b>  | Mechanized Loop Test                  |
| <b>PAU</b>  | PG-Plus Alarm Unit                    |
| <b>PMU</b>  | PG-Plus Management Unit               |
| <b>PRL</b>  | PG-Plus Remote Line unit              |
| <b>RLU</b>  | Remote Line Unit housed in RT         |
| <b>RMA</b>  | Return Materials Authorization        |
| <b>RT</b>   | Remote Terminal                       |
| <b>SDT</b>  | Subscriber Drop Test                  |



---

**World Headquarters:**

ADC Telecommunications, Inc.  
12501 Whitewater Drive  
Minnetonka, Minnesota USA 55343

**For Technical Assistance:**

800.366.3891



1251810

---