

# PG-PLUS

## TECHNICAL PRACTICE

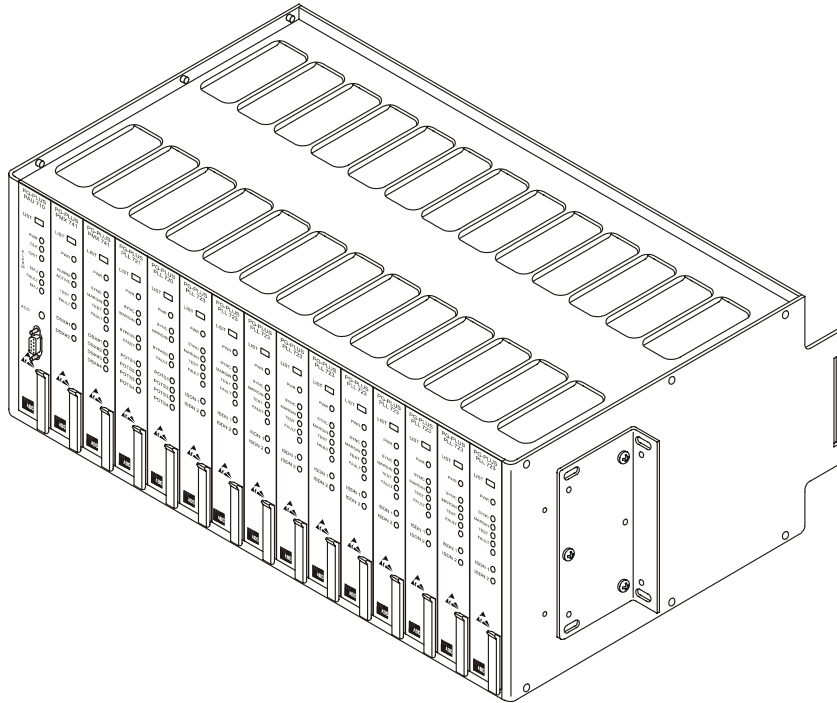

### 19" CENTRAL OFFICE TERMINAL SHELF

Model	List	CLEI Code
PCS-718	1	VAMCBC0A~~

---

**Revision History of This Practice**

---

<b>Revision</b>	<b>Release Date</b>	<b>Revisions Made</b>
04	June 21, 2000	Update fusing information and add HDSL backplane connection table
05	January 10, 2002	Release to rebrand document to comply with ADC standards
06	January 6, 2003	Updated Product Support Information

---

**©Copyright 2003 ADC DSL Systems, Inc. All Rights Reserved.**

*ADC is a registered trademark of ADC Technologies, Inc. PG-Plus is a registered trademark of ADC DSL Systems, Inc. No right, license, or interest to such trademarks is granted hereunder, and you agree that you shall assert no such right, license, or interest with respect to such trademarks. Other product names mentioned in this document are used for identification purposes only and may be trademarks or registered trademarks of their respective companies.*

*Information contained in this document is company private to ADC DSL Systems, Inc., and shall not be modified, used, copied, reproduced or disclosed in whole or in part without the written consent of ADC.*

*Contents herein are current as of the date of publication. ADC reserves the right to change specifications at any time without notice. Information furnished by ADC is believed to be accurate and reliable. In no event shall ADC be liable for any damages resulting from the loss of data, loss of use, or loss of profits and ADC further disclaims any and all liability for indirect, incidental, special, consequential or other similar damages. This disclaimer of liability applies to all products, publications and services during and after the warranty period.*

## USING THIS TECHNICAL PRACTICE

Two types of messages, identified by icons, appear in the text:



**Notes contain information about special circumstances.**



**Cautions indicate the possibility of equipment damage or the possibility of personal injury.**



## TABLE OF CONTENTS

<b>Overview</b>	<b>1</b>
Description and Features.....	1
Composite Clock Signals.....	2
Backplane Connections.....	2
Power.....	3
HDSL.....	3
Two-Wire Subscriber Circuits.....	3
Four-Wire Subscriber Circuits.....	3
COLU Edge Card Connectors.....	3
Alarm Cutoff.....	16
Alarm Contacts.....	16
Network Interface.....	17
LAN Interface.....	18
DSX1 Connections.....	18
PAU/PMU Connector.....	19
PMX Connectors.....	20
Specifications.....	22
<b>Installation and Test</b>	<b>23</b>
Required Tools and Test Equipment.....	23
Power.....	23
Powering the Integrated Systems.....	24
Powering the Universal Systems.....	25
Mounting.....	25
Installing the PCS-718 into a CO Equipment Frame.....	26
Heat Baffles.....	26
Wiring Access.....	26
Alarm Leads.....	26
HDSL Lines.....	26
Subscriber Lines.....	26
Connections.....	27
Ground Connections.....	27
Power Connections.....	27
Redundant Shelf Powering.....	28
Split Shelf Powering.....	29
Single Source Powering.....	30
Audible and Visual Alarm Connections.....	31

---

Subscriber Connections From CO .....	33
Composite Clock Connections.....	40
HDSL Wiring.....	42
External ACO Connection .....	44
Turn-Up and Test .....	44
<b>Product Support</b> .....	<b>45</b>
Technical Support.....	45
Limited Warranty .....	45
Returns.....	45
FCC Class A Compliance.....	47
Modifications.....	47
<b>Acronyms</b> .....	<b>48</b>

## LIST OF FIGURES

1. Front View of the PCS-718 COT Shelf.....	1
2. PCS-718 Shelf Backplane .....	2
3. Alarm Relay Contacts from PAU/PMU to COT Shelf Backplane Wire-Wrap Field .....	16
4. Modem Connection for FCS-717 Backplane .....	17
5. Null Modem Connection for FCS-717 Backplane .....	18
6. LAN Connector .....	18
7. Redundant Shelf Power Wiring.....	28
8. Split-Shelf Wiring .....	29
9. Single Source Power Wiring .....	30
10. Connecting the Alarm Relays.....	31
11. Connecting the Composite Clock.....	41
12. Connecting the HDSL Pairs .....	42
13. Connecting the External ACO Switch.....	44





---

**LIST OF TABLES**

1. PCS-718 Backplane Connectors.....	3
2. COLU #1 (J4) Connector Pinouts .....	4
3. COLU #2 (J5) Connector Pinouts .....	5
4. COLU #3 (J6) Connector Pinouts .....	6
5. COLU #4 (J7) Connector Pinouts .....	7
6. COLU #5 (J8) Connector Pinouts .....	8
7. COLU #6 (J9) Connector Pinouts .....	9
8. COLU #7 (J10) Connector Pinouts .....	10
9. COLU #8 (J11) Connector Pinouts .....	11
10. COLU #9 (J12) Connector Pinouts .....	12
11. COLU #10 (J13) Connector Pinouts .....	13
12. COLU #11 (J14) Connector Pinouts .....	14
13. COLU #12 (J15) Connector Pinouts .....	15
14. FCS-717 Backplane DB-25 Connector Pinouts .....	17
15. PAU/PMU 96-Pin DIN-Type Connector .....	19
16. PMX 1 160-Pin DIN-Type Connector .....	20
17. PMX 2 160-Pin DIN-Type Connector .....	21
18. PCS-718 Shelf Power and Heat Dissipation for Integrated Systems .....	24
19. PCS-718 Shelf Power and Heat Dissipation for Universal Systems .....	25
20. Alarm Terminations.....	32
21. P1 Tip and Ring Pin Assignments.....	33
22. P2 Tip and Ring Pin Assignments.....	34
23. P3 Tip and Ring Pin Assignments.....	35
24. P1 Telco Connector .....	36
25. P2 Telco Connector .....	37
26. P3 Telco Connector .....	38
27. P5 Telco Connector .....	39
28. PCS-718 HDSL Connections .....	43



# OVERVIEW

The ADC® PG-Plus® 19-inch Central Office Terminal (COT) shelf, PCS-718 List 1, supports a common management or alarm unit, two multiplexer units and up to twelve universal or integrated PG-Plus Central Office Line Units (COLUs) or up to six PG-Plus Integrated Central Office Line Units (FICOLUs).

## DESCRIPTION AND FEATURES

The PCS-718 provides convenient mounting of a PG-Plus Alarm Unit (PAU) or PG-Plus Management Unit (PMU), PG-Plus Multiplexer Units (PMXs) and Central Office Line Units (COLUs). Termination points for subscriber circuits, alarm, power, and metallic test access are located on the backplane at the rear of the COT shelf. All circuit boards are installed from the front of the COT shelf. The PCS-718 COT shelf accommodates the following units (see [Figure 1](#)):

- 12 COLUs or 6 FICOLUs
- Two PMXs
- One PAU or one PMU

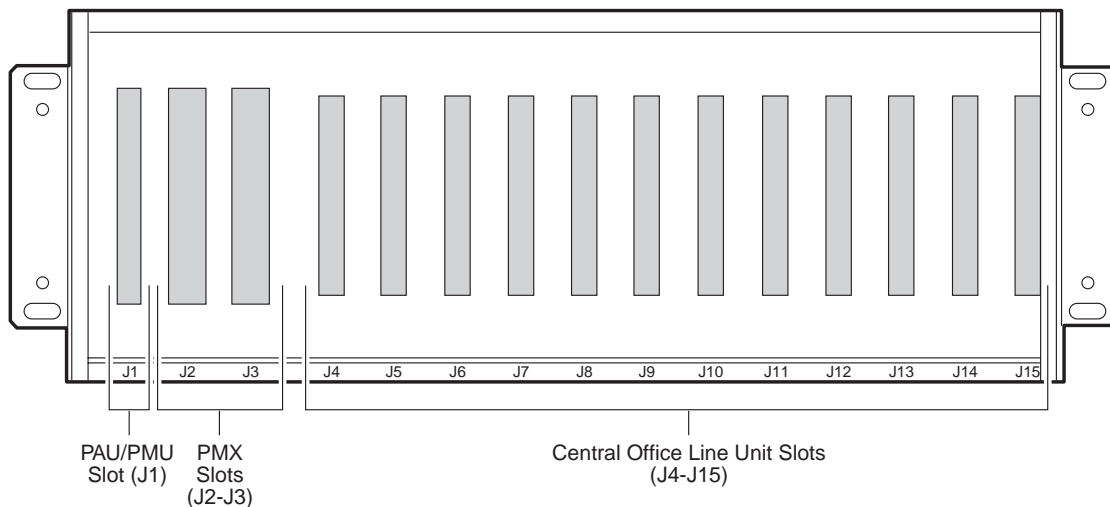

**Figure 1.** Front View of the PCS-718 COT Shelf

The PCS-718 COT shelf features include:

- Universal mounting brackets for installation into a 19-inch or 23-inch equipment rack
- Wire-wrap connections for HDSL, alarm cutoff, and alarm relays
- Screw terminal connections for frame ground and Central Office (CO) battery
- DB-25 connector for network communications
- BNC connector for inter-shelf communications
- 50-pin Telco connector for four-wire service connections
- 50-pin Telco connectors for two-wire service connections

## COMPOSITE CLOCK SIGNALS

Composite clock signals are a 64 kHz bipolar clock with 8 kHz bipolar violations, that define the bit and byte boundaries of DDS data as it is transferred within a CO. In support of DDS interfaces, PG-Plus defines two composite clock interfaces at the PAU/PMU card slot. The PAU/PMU selects the clock and translates it into bit and byte clocks, which it then distributes to the COLUs. Wire-wrap pins on the backplane allow the composite clock source to be terminated or daisy-chained to another shelf.

## BACKPLANE CONNECTIONS

Each shelf supports the connection of up to twelve COLUs or six FICOLUs, two PMX units, and one PAU or PMU. The backplane of the PCS-718 List 1 contains the connectors shown in Figure 2 and Table 1. Wiring external to the COT shelf should follow the provisions of the current edition of the National Electrical Code and applicable local codes.

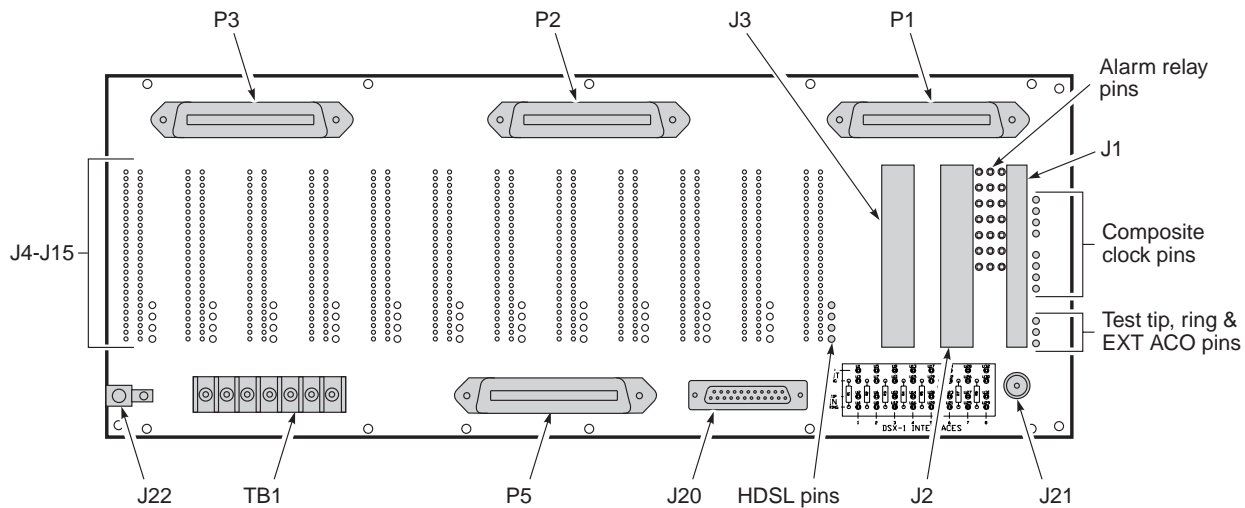

Figure 2. PCS-718 Shelf Backplane



Information in Tables 2 through 17 can be used for diagnostic and troubleshooting procedures under the direction of an authorized ADC technical support representative.

The following sections identify each connector by type and function.

**Table 1.** *PCS-718 Backplane Connectors*

Connector	Description
J1	PAU or PMU connector
J2	PMX 1 connector
J3	PMX 2 connector
J4 - J15	COLU HDSL connectors. The wire-wrap posts are for the HDSL.
J20	DB-25 (RS-232) connector
J21	10Base2 LAN connector
J22	Frame Ground
P1 - P3	Telco connectors
P5	Telco connector
TB1	Seven-position power terminal strip

## Power

The COT shelf backplane has a seven-position power terminal strip (TB1) that provides connections for dual –48 Vdc, common battery return, and frame ground by way of screw terminals. The COT shelf can be wired for redundant powering, split-powering, or single-source powering depending upon requirements.

## HDSL

Each COLU slot is equipped with four wire-wrap pins for xDSL interfaces.

## Two-Wire Subscriber Circuits

A total of 72 two-wire subscriber pairs terminate at the Telco connectors (P1, P2, and P3) on the COT shelf backplane. Six pairs route to each of the twelve COLU slots. See Tables 24 through 26 for the connector pinouts.

## Four-Wire Subscriber Circuits

The COT shelf provides a total of twelve four-wire data interfaces that are separate from the two-wire pairs. One four-wire connection is provided for each of the twelve COLU slots. See [Table 27 on page 39](#) for the connector pinouts.

## COLU Edge Card Connectors

Tables 2 through 13 show the backplane connector pinouts for each COLU slot.

**Table 2.** COLU #1 (J4) Connector Pinouts

Pin #	Assignment	Assignment	Pin #
49	TIP1	RING1	50
47	TIP2	RING2	48
45	TIP3	RING3	46
43	TIP4	RING4	44
41	TIP5	RING5	42
39	TIP6	RING6	40
37	<BURN IN>	-	38
35	CC8KA	CC64KA	36
33	INTRPT1-	SCB1	34
31	RDATA1	RDATB1	32
29	CLKA1	CLKB1	30
27	RSIGA1	RSIGB1	28
25	FSYNCA1	FSYNCB1	26
23	TDATA1	TDATB1	24
21	TSIGA1	TSIGB1	22
19	TSTTIP	TSTRING	20
17	GND	GND	18
15	BATA_L	BATA_L	16
13	BATB_L	BATB_L	14
11	-	-	12
9	HTIPA1	HTIPB1	10
7	HRINGA1	HRINGB1	8
5	FGND	FGND	6
3	4WRXT1	4WRXR1	4
1	4WTXT1	4WTXR1	2

**Table 3.** COLU #2 (J5) Connector Pinouts

Pin #	Assignment	Assignment	Pin #
49	TIP7	RING7	50
47	TIP8	RING8	48
45	TIP9	RING9	46
43	TIP10	RING10	44
41	TIP11	RING11	42
39	TIP12	RING12	40
37	<BURN IN>	–	38
35	CC8KA	CC64KA	36
33	INTRPT2-	SCB2	34
31	RDATA2	RDATB2	32
29	CLKA2	CLKB2	30
27	RSIGA2	RSIGB2	28
25	FSYNCA2	FSYNCB2	26
23	TDATA2	TDATB2	24
21	TSIGA2	TSIGB2	22
19	TSTTIP	TSTRING	20
17	GND	GND	18
15	BATA_L	BATA_L	16
13	BATB_L	BATB_L	14
11	–	–	12
9	HTIPA2	HTIPB2	10
7	HRINGA2	HRINGB2	8
5	FGND	FGND	6
3	4WRXT2	4WRXR2	4
1	4WTXT2	4WTXR2	2

**Table 4.** COLU #3 (J6) Connector Pinouts

Pin #	Assignment	Assignment	Pin #
49	TIP13	RING13	50
47	TIP14	RING14	48
45	TIP15	RING15	46
43	TIP16	RING16	44
41	TIP17	RING17	42
39	TIP18	RING18	40
37	<BURN IN>	–	38
35	CC8KA	CC64KA	36
33	INTRPT3-	SCB3	34
31	RDATA3	RDATB3	32
29	CLKA3	CLKB3	30
27	RSIGA3	RSIGB3	28
25	FSYNCA3	FSYNCB3	26
23	TDATA3	TDATB3	24
21	TSIGA3	TSIGB3	22
19	TSTTIP	TSTRING	20
17	GND	GND	18
15	BATA_L	BATA_L	16
13	BATB_L	BATB_L	14
11	–	–	12
9	HTIPA3	HTIPB3	10
7	HRINGA3	HRINGB3	8
5	FGND	FGND	6
3	4WRXT3	4WRXR3	4
1	4WTXT3	4WTXR3	2



**Table 5.** COLU #4 (J7) Connector Pinouts

Pin #	Assignment	Assignment	Pin #
49	TIP19	RING19	50
47	TIP20	RING20	48
45	TIP21	RING21	46
43	TIP22	RING22	44
41	TIP23	RING23	42
39	TIP24	RING24	40
37	<BURN IN>	–	38
35	CC8KA	CC64KA	36
33	INTRPT4-	SCB4	34
31	RDATA4	RDATB4	32
29	CLKA4	CLKB4	30
27	RSIGA4	RSIGB4	28
25	FSYNCA4	FSYNCB4	26
23	TDATA4	TDATB4	24
21	TSIGA4	TSIGB4	22
19	TSTTIP	TSTRING	20
17	GND	GND	18
15	BATA_L	BATA_L	16
13	BATB_L	BATB_L	14
11	–	–	12
9	HTIPA4	HTIPB4	10
7	HRINGA4	HRINGB4	8
5	FGND	FGND	6
3	4WRXT4	4WRXR4	4
1	4WTXT4	4WTXR4	2

**Table 6.** COLU #5 (J8) Connector Pinouts

Pin #	Assignment	Assignment	Pin #
49	TIP25	RING25	50
47	TIP26	RING26	48
45	TIP27	RING27	46
43	TIP28	RING28	44
41	TIP29	RING29	42
39	TIP30	RING30	40
37	<BURN IN>	–	38
35	CC8KA	CC64KA	36
33	INTRPT5-	SCB5	34
31	RDATA5	RDATB5	32
29	CLKA5	CLKB5	30
27	RSIGA5	RSIGB5	28
25	FSYNCA5	FSYNCB5	26
23	TDATA5	TDATB5	24
21	TSIGA5	TSIGB5	22
19	TSTTIP	TSTRING	20
17	GND	GND	18
15	BATA_L	BATA_L	16
13	BATB_L	BATB_L	14
11	–	–	12
9	HTIPA5	HTIPB5	10
7	HRINGA5	HRINGB5	8
5	FGND	FGND	6
3	4WRXT5	4WRXR5	4
1	4WTXT5	4WTXR5	2

**Table 7.** COLU #6 (J9) Connector Pinouts

Pin #	Assignment	Assignment	Pin #
49	TIP31	RING31	50
47	TIP32	RING32	48
45	TIP33	RING33	46
43	TIP34	RING34	44
41	TIP35	RING35	42
39	TIP36	RING36	40
37	<BURN IN>	–	38
35	CC8KA	CC64KA	36
33	INTRPT6-	SCB6	34
31	RDATA6	RDATB6	32
29	CLKA6	CLKB6	30
27	RSIGA6	RSIGB6	28
25	FSYNCA6	FSYNCB6	26
23	TDATA6	TDATB6	24
21	TSIGA6	TSIGB6	22
19	TSTTIP	TSTRING	20
17	GND	GND	18
15	BATA_L	BATA_L	16
13	BATB_L	BATB_L	14
11	–	–	12
9	HTIPA6	HTIPB6	10
7	HRINGA6	HRINGB6	8
5	FGND	FGND	6
3	4WRXT6	4WRXR6	4
1	4WTXT6	4WTXR6	2

**Table 8.** COLU #7 (J10) Connector Pinouts

Pin #	Assignment	Assignment	Pin #
49	TIP37	RING37	50
47	TIP38	RING38	48
45	TIP39	RING39	46
43	TIP40	RING40	44
41	TIP41	RING41	42
39	TIP42	RING42	40
37	<BURN IN>	–	38
35	CC8KA	CC64KA	36
33	INTRPT7-	SCB7	34
31	RDATA7	RDATB7	32
29	CLKA7	CLKB7	30
27	RSIGA7	RSIGB7	28
25	FSYNCA7	FSYNCB7	26
23	TDATA7	TDATB7	24
21	TSIGA7	TSIGB7	22
19	TSTTIP	TSTRING	20
17	GND	GND	18
15	BATA_H	BATA_H	16
13	BATB_H	BATB_H	14
11	–	–	12
9	HTIPA7	HTIPB7	10
7	HRINGA7	HRINGB7	8
5	FGND	FGND	6
3	4WRXT7	4WRXR7	4
1	4WTXT7	4WTXR7	2

**Table 9.** COLU #8 (J11) Connector Pinouts

Pin #	Assignment	Assignment	Pin #
49	TIP43	RING43	50
47	TIP44	RING44	48
45	TIP45	RING45	46
43	TIP46	RING46	44
41	TIP47	RING47	42
39	TIP48	RING48	40
37	<BURN IN>	–	38
35	CC8KA	CC64KA	36
33	INTRPT8-	SCB8	34
31	RDATA8	RDATB8	32
29	CLKA8	CLKB8	30
27	RSIGA8	RSIGB8	28
25	FSYNCA8	FSYNCB8	26
23	TDATA8	TDATB8	24
21	TSIGA8	TSIGB8	22
19	TSTTIP	TSTRING	20
17	GND	GND	18
15	BATA_H	BATA_H	16
13	BATB_H	BATB_H	14
11	–	–	12
9	HTIPA8	HTIPB8	10
7	HRINGA8	HRINGB8	8
5	FGND	FGND	6
3	4WRXT8	4WRXR8	4
1	4WTXT8	4WTXR8	2

**Table 10.** COLU #9 (J12) Connector Pinouts

Pin #	Assignment	Assignment	Pin #
49	TIP49	RING49	50
47	TIP50	RING50	48
45	TIP51	RING51	46
43	TIP52	RING52	44
41	TIP53	RING53	42
39	TIP54	RING54	40
37	<BURN IN>	–	38
35	CC8KB	CC64KB	36
33	INTRPT9-	SCB9	34
31	RDATA9	RDATB9	32
29	CLKA9	CLKB9	30
27	RSIGA9	RSIGB9	28
25	FSYNCA9	FSYNCB9	26
23	TDATA9	TDATB9	24
21	TSIGA9	TSIGB9	22
19	TSTTIP	TSTRING	20
17	GND	GND	18
15	BATA_H	BATA_H	16
13	BATB_H	BATB_H	14
11	–	–	12
9	HTIPA9	HTIPB9	10
7	HRINGA9	HRINGB9	8
5	FGND	FGND	6
3	4WRXT9	4WRXR9	4
1	4WTXT9	4WTXR9	2

**Table 11.** COLU #10 (J13) Connector Pinouts

Pin #	Assignment	Assignment	Pin #
49	TIP55	RING55	50
47	TIP56	RING56	48
45	TIP57	RING57	46
43	TIP58	RING58	44
41	TIP59	RING59	42
39	TIP60	RING60	40
37	<BURN IN>	–	38
35	CC8KB	CC64KB	36
33	INTRPT10-	SCB10	34
31	RDATA10	RDATB10	32
29	CLKA10	CLKB10	30
27	RSIGA10	RSIGB10	28
25	FSYNCA10	FSYNCB10	26
23	TDATA10	TDATB10	24
21	TSIGA10	TSIGB10	22
19	TSTTIP	TSTRING	20
17	GND	GND	18
15	BATA_H	BATA_H	16
13	BATB_H	BATB_H	14
11	–	–	12
9	HTIPA10	HTIPB10	10
7	HRINGA10	HRINGB10	8
5	FGND	FGND	6
3	4WRXT10	4WRXR10	4
1	4WTXT10	4WTXR10	2

**Table 12.** COLU #11 (J14) Connector Pinouts

Pin #	Assignment	Assignment	Pin #
49	TIP61	RING61	50
47	TIP62	RING62	48
45	TIP63	RING63	46
43	TIP64	RING64	44
41	TIP65	RING65	42
39	TIP66	RING66	40
37	<BURN IN>	–	38
35	CC8KB	CC64KB	36
33	INTRPT11-	SCB11	34
31	RDATA11	RDATB11	32
29	CLKA11	CLKB11	30
27	RSIGA11	RSIGB11	28
25	FSYNCA11	FSYNCB11	26
23	TDATA11	TDATB11	24
21	TSIGA11	TSIGB11	22
19	TSTTIP	TSTRING	20
17	GND	GND	18
15	BATA_H	BATA_H	16
13	BATB_H	BATB_H	14
11	–	–	12
9	HTIPA11	HTIPB11	10
7	HRINGA11	HRINGB11	8
5	FGND	FGND	6
3	4WRXT11	4WRXR11	4
1	4WTXT11	4WTXR11	2



**Table 13.** COLU #12 (J15) Connector Pinouts

Pin #	Assignment	Assignment	Pin #
49	TIP67	RING67	50
47	TIP68	RING68	48
45	TIP69	RING69	46
43	TIP70	RING70	44
41	TIP71	RING71	42
39	TIP72	RING72	40
37	<BURN IN>	–	38
35	CC8KB	CC64KB	36
33	INTRPT12-	SCB12	34
31	RDATA12	RDATB12	32
29	CLKA12	CLKB12	30
27	RSIGA12	RSIGB12	28
25	FSYNCA12	FSYNCB12	26
23	TDATA12	TDATB12	24
21	TSIGA12	TSIGB12	22
19	TSTTIP	TSTRING	20
17	GND	GND	18
15	BATA_H	BATA_H	16
13	BATB_H	BATB_H	14
11	–	–	12
9	HTIPA12	HTIPB12	10
7	HRINGA12	HRINGB12	8
5	FGND	FGND	6
3	4WRXT12	4WRXR12	4
1	4WTXT12	4WTXR12	2

## Alarm Cutoff

The shelf backplane provides a wire-wrap pin for connection to an external alarm cutoff circuit.

## Alarm Contacts

The COT shelf provides access to the PAU/PMU alarm relays by way of wire-wrap pins on the COT shelf backplane. Both normally open (NO) and normally closed (NC) relay operation is supported. Figure 3 shows the configuration of the alarm relays.

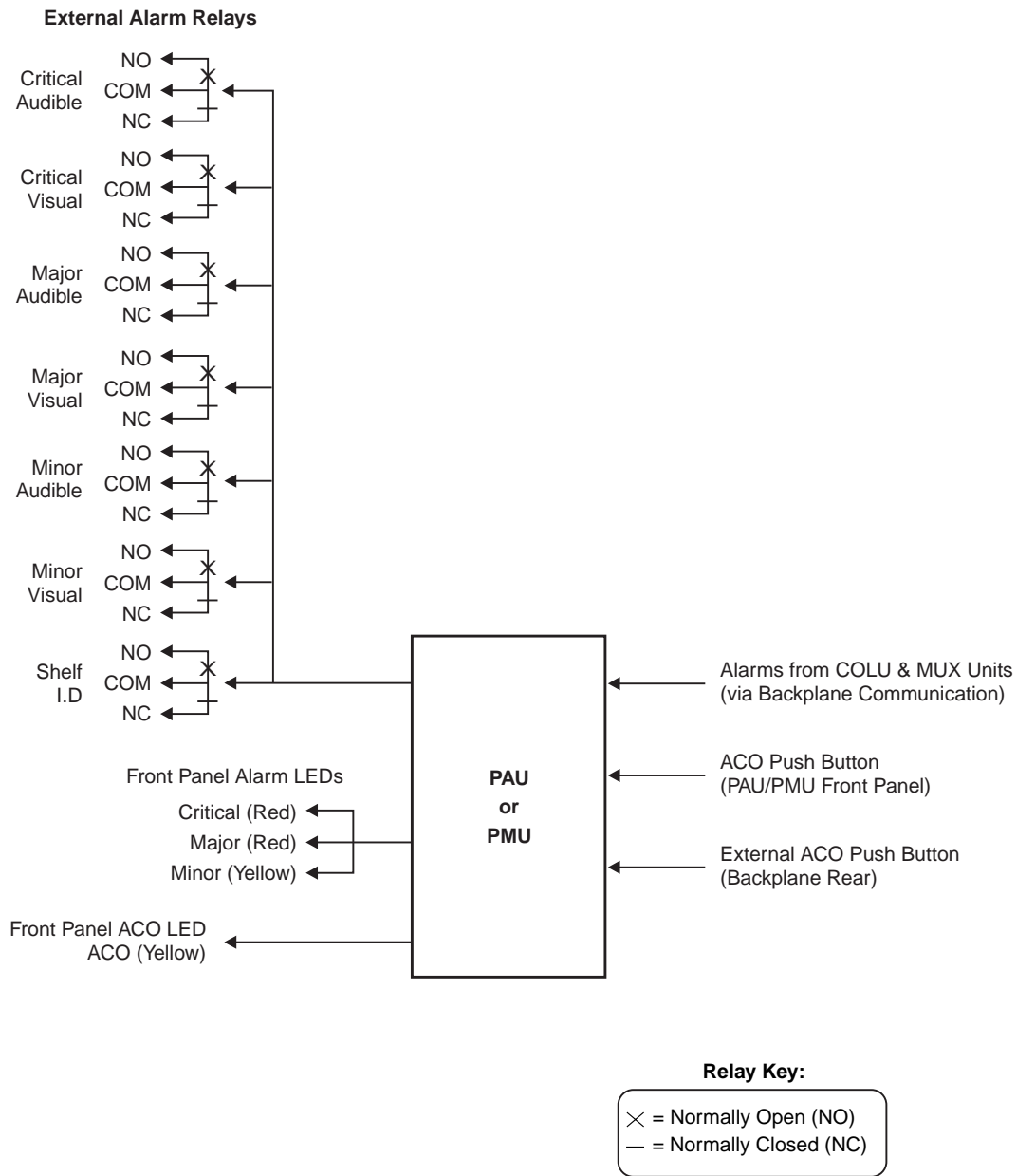

**Figure 3.** Alarm Relay Contacts from PAU/PMU to COT Shelf Backplane Wire-Wrap Field



Relay contacts are shown when alarm is not active.

## Network Interface

The COT shelf supports RS-232 X.25 interfaces through a backplane-mounted DB25 connector. The rear backplane DB-25 is a female connector wired as a Data Terminal Equipment (DTE) interface. The signals and pin assignments for this connector are listed in [Table 14](#). This connector is for communication with a DCE device such as a modem. [Figure 4](#) shows the cable connections between the backplane connector and a DCE DB-25 connector. To connect to a DTE device from the backplane connector, a null modem cable is required. [Figure 5](#) shows the wiring for the required null modem cable to a DB-9 and DB-25 connector. This feature requires a PMU installed in the COT shelf. Refer to the PMU documentation for additional information on this interface.

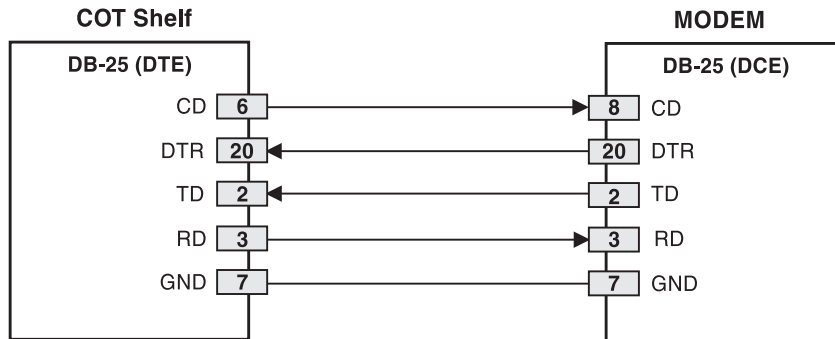

**Figure 4.** Modem Connection for FCS-717 Backplane

**Table 14.** FCS-717 Backplane DB-25 Connector Pinouts

DB-25 Pin	Signal
2	Transmitted Data
3	Received Data
8	Carrier Detect
7	Signal Common
20	Data Terminal Ready

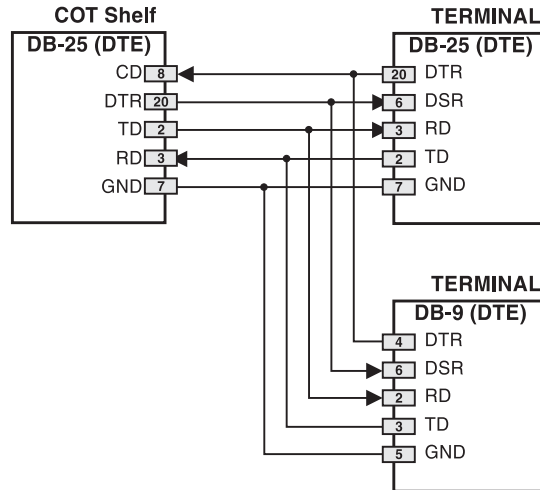

Figure 5. Null Modem Connection for FCS-717 Backplane

### LAN Interface

The COT shelf supports communications between multiple shelves by means of a 10Base2 BNC LAN connector. This feature requires a PMU installed in the COT shelf. Refer to the PMU documentation for additional information on this interface. Figure 6 shows the 10Base2 LAN connector.

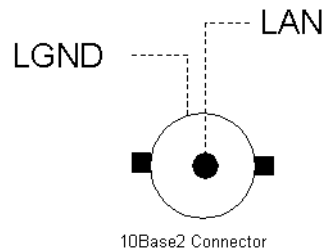

Figure 6. LAN Connector

### DSX1 Connections

The COT shelf provides terminations for eight DS1 inputs from the DSX-1 cross-connect by way of wire-wrap pins located at the bottom right hand side of the shelf backplane. The DS1 inputs are bridged to both PMX slots to allow for 1:1 equipment protection. The 100 Ω termination resistors are included on each of the DSX1 IN connections.

## PAU/PMU Connector

J1 on the COT shelf backplane is the 96-pin DIN-type PAU/PMU connector. Table 15 lists the PAU/PMU connector pinouts.

**Table 15.** PAU/PMU 96-Pin DIN-Type Connector

Pin #	Row A	Row B	Row C
32	MJRAUDNO	MJRAUDCOM	MJRAUDNC
31	MJRVISNO	MJRVISCOM	MJRVISNC
30	MNRAUDNO	MNRAUDCOM	MNRAUDNC
29	MNRVISNO	MNRVISCOM	MNRVISNC
28	CRITAUDNO	CRITAUDCOM	CRITAUDNC
27	CRITVISNO	CRITVISCOM	CRITVISNC
26	SYSNO	SYSCOM	SYSNC
25	SCB1	INTRPT1-	CC1TIP
24	SCB2	INTRPT2-	CC1RING
23	SCB3	INTRPT3-	CC2TIP
22	SCB4	INTRPT4-	CC2RING
21	SCB5	INTRPT5-	ACO1
20	SCB6	INTRPT6-	GND
19	SCB7	INTRPT7-	TSTTIP
18	SCB8	INTRPT8-	TSTRING
17	SCB9	INTRPT9-	CC64KA
16	SCB10	INTRPT10-	CC8KA
15	SCB11	INTRPT11-	CC64KB
14	SCB12	INTRPT12-	CC8KB
13	SCB13	INTRPT13-	INTRPTA-
12	SCB14	INTRPT14-	FSYNCAEOC
11	SCB15	INTRPT15-	RCLKAEOC
10	SCB16	INTRPT16-	INTRPTB-
9	SCBA	SCBB	FSYNCBEOC
8	BATB_H	TDATBEOC	RCLKBEOC
7	RDATAEOC	RDATBEOC	
6	BATA_L	TDATAEOC	FGND
5	GND	ID1	ID0
4	NMATX	NMARX	<BURN IN>
3	NMADTR	NMADSR	NMAGND
2	NMACD	NMARCLK	NMATCLK
1	LAN	LGND	LGND

## PMX Connectors

J2 and J3 on the COT shelf backplane are the 160-pin DIN-type PMX connectors. [Table 16](#) lists the connector pinouts for PMX 1 (J2 on the backplane). [Table 17 on page 21](#) lists the connector pinouts for PMX 2 (J3 on the backplane).

**Table 16.** *PMX 1 160-Pin DIN-Type Connector*

Pin #	Row A	Row B	Row C	Row D	Row E
32	RDATA1	RDATA2	RDATA3	RDATA4	RDATA5
31	RSIGA1	RSIGA2	RSIGA3	RSIGA4	RSIGA5
30	TDATA1	TDATA2	TDATA3	TDATA4	TDATA5
29	TSIGA1	TSIGA2	TSIGA3	TSIGA4	TSIGA5
28	CLKA1	CLKA2	CLKA3	CLKA4	CLKA5
27	FSYNCA1	FSYNCA2	FSYNCA3	FSYNCA4	FSYNCA5
26	GND	GND	GND	GND	GND
25	RDATA6	RDATA7	RDATA8	RDATA9	RDATA10
24	RSIGA6	RSIGA7	RSIGA8	RSIGA9	RSIGA10
23	TDATA6	TDATA7	TDATA8	TDATA9	TDATA10
22	TSIGA6	TSIGA7	TSIGA8	TSIGA9	TSIGA10
21	CLKA6	CLKA7	CLKA8	CLKA9	FSYNCA10
20	FSYNCA6	FSYNCA7	FSYNCA8	FSYNCA9	CLKA10
19	GND	GND	GND	GND	GND
18	RDATA11	RDATA12	RDATA13	RDATA14	RDATA15
17	RSIGA11	RSIGA12	RSIGA13	RSIGA14	RSIGA15
16	TDATA11	TDATA12	TDATA13	TDATA14	TDATA15
15	TSIGA11	TSIGA12	TSIGA13	TSIGA14	TSIGA15
14	CLKA11	CLKA12	CLKA13	CLKA14	CLKA15
13	FSYNCA11	FSYNCA12	FSYNCA13	FSYNCA14	FSYNCA15
12	RDATA16	RSIGA16	CLKA16	SCBA	RDATAEOC
11	BATA_L	TSIGA16	FSYNCA16	INTRPTA-	TDATAEOC
10	BATA_L	TDATA16	RCLKAEOC	FSYNCAEOC	BATB_H
9	B2A	GND	A2B	GND	BATB_H
8	-	-	-	-	<RESERVED>
7	RXTIP1	RXTIP4	TXTIP4	RXTIP7	FGND
6	RXRING1	RXRING4	TXRING4	RXRING7	FGND
5	TXTIP1	RXTIP3	RXTIP5	TXTIP7	-
4	TXRING1	RXRING3	RXRING5	TXRING7	RXTIP8
3	RXTIP2	TXTIP3	TXTIP5	RXTIP6	RXRING8
2	RXRING2	TXRING3	TXRING5	RXRING6	TXTIP8
1	TXTIP2	TXRING2	TXRING6	TXTIP6	TXRING8

**Table 17.** PMX 2 160-Pin DIN-Type Connector

Pin #	Row A	Row B	Row C	Row D	Row E
32	RDATB1	RDATB2	RDATB3	RDATB4	RDATB5
31	RSIGB1	RSIGB2	RSIGB3	RSIGB4	RSIGB5
30	TDATB1	TDATB2	TDATB3	TDATB4	TDATB5
29	TSIGB1	TSIGB2	TSIGB3	TSIGB4	TSIGB5
28	CLKB1	CLKB2	CLKB3	CLKB4	CLKB5
27	FSYNCB1	FSYNCB2	FSYNCB3	FSYNCB4	FSYNCB5
26	GND	GND	GND	GND	GND
25	RDATB6	RDATB7	RDATB8	RDATB9	RDATB10
24	RSIGB6	RSIGB7	RSIGB8	RSIGB9	RSIGB10
23	TDATB6	TDATB7	TDATB8	TDATB9	TDATB10
22	TSIGB6	TSIGB7	TSIGB8	TSIGB9	TSIGB10
21	CLKB6	CLKB7	CLKB8	CLKB9	FSYNCB10
20	FSYNCB6	FSYNCB7	FSYNCB8	FSYNCB9	CLKB10
19	GND	GND	GND	GND	GND
18	RDATB11	RDATB12	RDATB13	RDATB14	RDATB15
17	RSIGB11	RSIGB12	RSIGB13	RSIGB14	RSIGB15
16	TDATB11	TDATB12	TDATB13	TDATB14	TDATB15
15	TSIGB11	TSIGB12	TSIGB13	TSIGB14	TSIGB15
14	CLKB11	CLKB12	CLKB13	CLKB14	CLKB15
13	FSYNCB11	FSYNCB12	FSYNCB13	FSYNCB14	FSYNCB15
12	RDATB16	RSIGB16	CLKB16	SCBB	RDATBEOC
11	BATA_L	TSIGB16	FSYNCB16	INTRPTB-	TDATBEOC
10	BATA_L	TDATB16	RCLKBEOC	FSYNCBEOC	BATB_H
9	A2B	GND	B2A	GND	BATB_H
8	-	-	-	-	<RESERVED>
7	RXTIP1	RXTIP4	TXTIP4	RXTIP7	FGND
6	RXRING1	RXRING4	TXRING4	RXRING7	FGND
5	TXTIP1	RXTIP3	RXTIP5	TXTIP7	-
4	TXRING1	RXRING3	RXRING5	TXRING7	RXTIP8
3	RXTIP2	TXTIP3	TXTIP5	RXTIP6	RXRING8
2	RXRING2	TXRING3	TXRING5	RXRING6	TXTIP8
1	TXTIP2	TXRING2	TXRING6	TXTIP6	TXRING8

## SPECIFICATIONS

### Environmental

Operating Elevation	-200 ft to 13,000 ft (-60 m to 4,000 m)
Temperature	-40° F to +150° F (-40° C to +65°C)
Operating Humidity	5% to 95% (noncondensing)

### Compliance

NEBS	SR-3580 for Level 3*
Human Safety	UL 1950 for Restricted Access
Emissions Radiation and Immunity	GR-1089-CORE for Class A Equipment

### Dimensions

Height	8.75 in. (22.2 cm.)*
Width	19.0 in. (48.3 cm.)
Depth	11.75 in. (29.8 cm.)
Weight	10.2 lbs. (4.5 kg.) <sup>(b)</sup>

---

\* When the heat baffle assembly 130-1100-01 is attached. For NEBS level 3 compliance, the COT shelf must include the heat baffle assembly. Using the heat baffle assembly, the height will increase to 8.75 in. (22.2 cm.) and the weight will increase to 15 lbs. (6.8 kg.)

---



---

# INSTALLATION AND TEST

## REQUIRED TOOLS AND TEST EQUIPMENT

The tools and test equipment required for the installation of the COT shelf are:

- Wire-wrap tool for .045-inch square pins
- No. 2 Phillips screwdriver
- Flat-head screwdriver
- Wire-strippers
- Side-cutters
- Volt-ohmmeter

## POWER

The COT shelf uses –48 Vdc CO battery. This voltage must be fused on a fuse panel in the CO. The fuse rating depends on the powering option used.

## Powering the Integrated Systems

Table 18 summarizes the shelf powering requirements and heat dissipation for the PG-Flex<italics 10>PG Plus COT shelf when it is fully populated with services, a battery voltage of  $-48.0\text{ V}$ , and with all CO to RT distances at their maximum DSL reach. The table provides the average current drawn from a fully populated shelf under the these conditions.



The conditions in Table 18 assume that the POTS lines at all customer sites are off hook.

The configuration used for computing the shelf current and heat dissipation includes two PMXs and one PAU or PMU.

**Table 18.** PCS-718 Shelf Power and Heat Dissipation for Integrated Systems

Service	Models	Split Powering		Single or Redundant Powering		CO Heat Dissipation
		CO Input Current <sup>*</sup>	Shelf Fuse <sup>†</sup>	CO Input Current <sup>(a)</sup>	Shelf Fuse <sup>(b)</sup>	
4 POTS	PLL-725 PRL-770	1.94 A	3.00 A	3.62 A	5.00 A	61 W
6 POTS	PLL-725 PRL-771	2.36 A	3.00 A	4.46 A	7.50 A	67 W
3 POTS, 1 ISDN	PLL-725 PRL-772	1.88 A	3.00 A	3.00 A	5.00 A	62 W
2 ISDN	PLL-725 PRL-773	1.58 A	2.00 A	2.90 A	5.00 A	61 W
6 UVG	PLL-725 PRL-779	2.77 A	5.00 A	5.28 A	7.50 A	79 W
4 POTS (dual)	PLL-735 PRL-770	3.49 A	5.00 A	6.64 A	10.00 A	94 W
6 POTS (dual)	PLL-735 PRL-771	4.33 A	7.50 A	8.32 A	12.00 A	105 W
3 POTS, 1 ISDN (dual)	PLL-735 PRL-772	3.37 A	5.00 A	6.41 A	10.00 A	96 W
2 ISDN (dual)	PLL-735 PRL-773	2.76 A	5.00 A	5.17 A	7.50 A	93 W
6 UVG (dual)	PLL-735 PRL-779	5.18 A	7.50 A	10.01 A	15.00 A	133 W
24 POTS <sup>‡</sup> (No Doublers)	FLL-814 FRL-842	4.90 A	7.50 A	9.46 A	15.00 A	106 W
24 POTS <sup>(c)</sup> (1 Doubler)	FLL-814 FRL-842	5.34 A	7.50 A	10.34 A	15.00 A	112 W
24 POTS <sup>(c)</sup> (2 Doublers)	FLL-814 FRL-842	5.99 A	7.50 A	11.64 A	20.00 A	123 W
24 POTS <sup>**</sup> (No Doublers)	FLL-814 FRL-842	3.56 A	5.00 A	6.75 A	10.00 A	84 W
24 POTS <sup>(d)</sup> (1 Doubler)	FLL-814 FRL-842	4.00 A	7.50 A	7.63 A	12.00 A	102 W
24 POTS <sup>(d)</sup> (2 Doublers)	FLL-814 FRL-842	4.38 A	7.50 A	8.38 A	12.00 A	102 W

(\*) Indicates the current when all lines are off hook with all DSL lines at maximum length with  $-48\text{ Vdc}$  battery.

(†) Indicates the recommended fuse for  $-42.5\text{ Vdc}$  battery and 15% fuse margin.

(‡) Indicates the subscriber drop set for LONG is  $\leq 960\ \Omega$ .

(\*\*) Indicates the subscriber drop set for SHORT is  $\leq 830\ \Omega$ .

## Powering the Universal Systems

**Table 19** summarizes the shelf powering requirements and heat dissipation for the PG-Flex<italics 10>PG Plus COT shelf when it is fully populated with services, a battery voltage of –48.0 V, and with all CO to RT distances at their maximum DSL reach. The table provides the average current drawn from a fully populated shelf under the these conditions.



The conditions in **Table 19** assume that the POTS lines at all customer sites are off hook.

The configuration used for computing the shelf current and heat dissipation includes one PAU or PMU.

**Table 19.** PCS-718 Shelf Power and Heat Dissipation for Universal Systems

Service	Models	Split Powering		Single or Redundant Powering		CO Heat Dissipation
		CO Input Current*	Shelf Fuse †	CO Input Current (a)	Shelf Fuse (b)	
4 POTS	PLL-720 PRL-770	1.95 A	3.00 A	3.85 A	7.50 A	100 W
6 POTS	PLL-721 PRL-771	2.40 A	3.00 A	4.75 A	7.50 A	122 W
3 POTS, 1 ISDN	PLL-722 PRL-772	1.86 A	3.00 A	3.68 A	5.00 A	91 W
2 ISDN	PLL-723 PRL-773	1.50 A	2.00 A	2.95 A	5.00 A	64 W
1 POTS, 1 ISDN	PLL-724 PRL-774	1.62 A	2.00 A	3.19 A	5.00 A	73 W
3 UVG, 1DDS	PLL-726 PRL-776	1.98 A	3.00 A	3.90 A	7.50 A	84 W
6 UVG	PLL-729 PRL-779	2.60 A	5.00 A	5.16 A	7.50 A	115 W
4 EBS	PLL-733 PRL-783	1.59 A	2.00 A	3.12 A	5.00 A	90 W
2 PLUS 2	PLL-734 PRL-784	2.24 A	3.00 A	4.42 A	7.50 A	116 W

(\*) Indicates the current when all lines are off hook with all DSL lines at maximum length with –48 Vdc battery.

(†) Indicates the recommended fuse for –42.5 Vdc battery and 15% fuse margin.

## MOUNTING

Attach the COT shelf to the selected position in the 19-inch or 23-inch equipment frame using the supplied hardware. For 23-inch frame installations, reverse the mounting brackets on the shelf.



The PCS-718 COT shelf is intended for installation on or above concrete or other noncombustible surfaces only.

## Installing the PCS-718 into a CO Equipment Frame

The Network Equipment Building Standard (NEBS) limits the maximum dissipation in a 12-inch deep individual CO equipment frame, with open-faced mounting and natural convection cooling, to 946 W (Watts). Refer to each individual line unit technical practice to determine the maximum number of units that can occupy any bay with the 946 W limit.

### Heat Baffles

One rack space minimum of 1<sup>3</sup>/<sub>4</sub> inch should be left open below each shelf for proper natural convection cooling of the electronics. Heat dissipating equipment below this shelf must have a baffle installed allowing this unit cool airflow. When multiple shelves are mounted in a frame, a heat baffle assembly, 130-1100-01, should be installed on each shelf.

## WIRING ACCESS

All wiring to the COT shelf is done on the backplane. To access the backplane, remove the clear Plexiglas™ cover.

### ALARM LEADS

Audible and visual alarm leads from the CO alarm panel to the COT shelf must be provided. Run the Alarm leads down the side of the COT shelf mounting frame.

### HDSL LINES

Depending on the type of COLU being installed, one or two pair from the COT shelf to the HDSL Tip and Ring pair(s) at the distribution frame must be provided for each system in the COT shelf. These leads should be dressed along the side of the frame per local practices.

### SUBSCRIBER LINES

Three 50-pin Telco-ended (female) cables per system are required for connecting the COT shelf to the CO switch subscriber line circuits at the distribution frame. Dress the cables along the sides of the frame per local practices.

## CONNECTIONS

### Ground Connections



**Frame Ground must be connected to provide a discharge path for outside plant protection circuits.**

Two Frame Ground termination points are provided on the COT shelf. The J22 and TB1 FGND Frame Ground termination points are electrically equivalent. To ground the COT shelf, do one of the following ground connection options:

- J22 Connection

The preferred termination point is at J22, located on the lower left corner of the COT shelf backplane. This ground lug will accept wire in the range of 6 to 12 AWG.



**Use this connection only if the equipment frame has a common equipment ground wire running along the vertical member of the frame.**

- 1 Using a wire gauge of the same size as the common equipment frame ground wire, remove 5/8-inch of insulation and insert the stripped wire into the ground lug J22.
  - 2 Using a flat-head screwdriver, secure the wire in the lug.
  - 3 Attach the other end to the common equipment frame ground using locally approved methods.
- TB1 FGND Connection
- The TB1 termination point is on the shelf backplane. A minimum of 12 AWG wire should be used for this connection.
- 1 Using minimum 12 AWG wire, attach a spade lug connector to terminate the ground wire on the FGND terminal of TB1.
  - 2 Connect the other end of the frame ground wire to the CO Frame Ground termination point using locally approved methods.

### Power Connections

The TB1 termination point on the COT shelf backplane provides connections for dual –48 Vdc, common battery return, and frame ground by way of screw terminals. The shelf can be wired for redundant powering, split-powering, or single-source powering depending upon requirements. The following sections describe the three powering options available on this device. The preferred powering method is the redundant shelf powering. Prior to performing any power connections:

- 1 Remove all fuses in the equipment bay's fuse panel for the circuit(s) where the –48 Vdc power leads will be terminated until the COT shelf is wired and ready for turn-up.
- 2 Run the battery and battery return lines from the fuse panel to the COT shelf using a minimum of 12 AWG wire.
- 3 Connect to a reliably grounded –48 Vdc source that is electrically isolated from the AC source.
- 4 The –48 Vdc circuits should be fused according to [Table 18 on page 24](#) and [Table 19 on page 25](#).
- 5 Disconnect both input supply sources before servicing.

## Redundant Shelf Powering

In this configuration, each circuit card in the COT shelf receives power from two –48 Vdc sources. If one –48 Vdc source is lost, the other –48 Vdc source provides power to the shelf circuit cards. Each –48 Vdc source should be fused according to [Table 18 on page 24](#) and [Table 19 on page 25](#).

A four-position jumper is in place on the TB1 block ([Figure 7](#)). This jumper shorts all of the 48 VDC inputs together to prevent an alarm condition when only one input feed wire is connected. To provide redundant shelf powering:

- 1 Ensure that the ground connection is in place.
- 2 Remove the four-position jumper from TB1.
- 3 Cut the four-position jumper in half, snipping out a small strip to ensure a gap between the two pieces when they are replaced.
- 4 Replace the two pieces on the TB1 block, connecting TB1-1 to TB1-2 with one piece; then TB1-3 to TB1-4 with the second piece.
- 5 Connect a wire from the –48A-LOW terminal of TB1 to the CO A battery supply terminal at the fuse panel.
- 6 Connect a wire from the –48B-HIGH terminal of TB1 to the CO B battery supply terminal at the fuse panel.
- 7 Connect a wire from the Battery Return terminal in position 5 of TB1 to the CO A battery return at the fuse panel.
- 8 Connect a wire from the Battery Return terminal in position 6 of TB1 to the CO B battery return at the fuse panel.

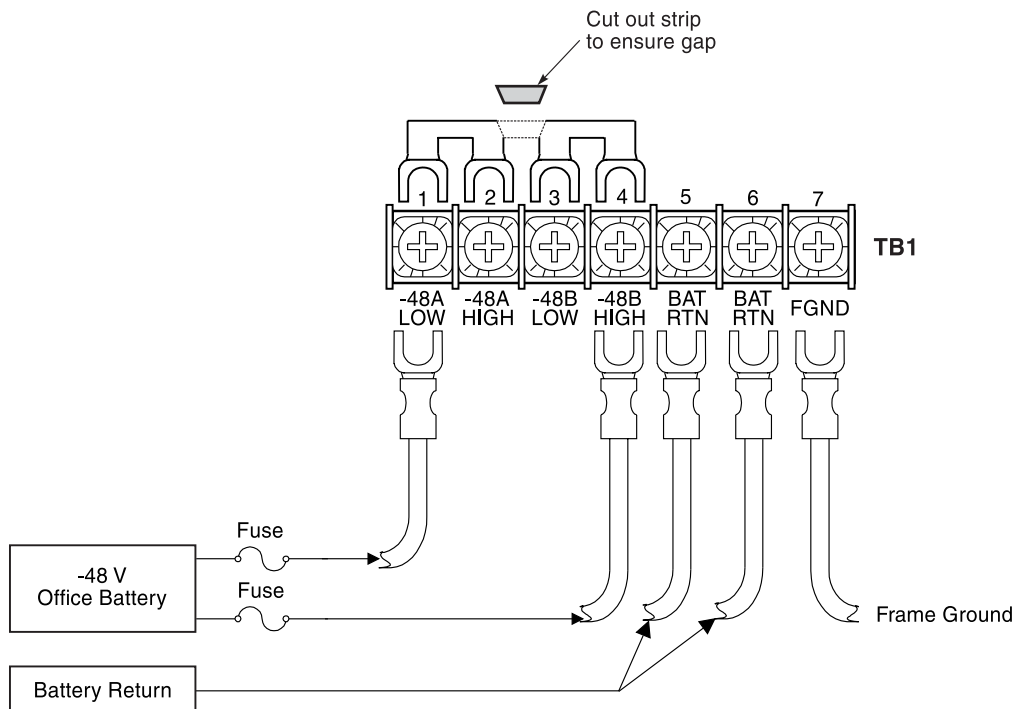

**Figure 7.** Redundant Shelf Power Wiring

## Split Shelf Powering

In this configuration, one half of the shelf is powered from one –48 Vdc source, the other half is powered from another –48 Vdc source. Common equipment circuit cards are powered from both sources. If one power supply should fail, one-half of the shelf maintains power. Each –48 Vdc source should be fused according to [Table 18 on page 24](#) and [Table 19 on page 25](#).

A four-position jumper is in place on the TB1 block. This jumper shorts all of the 48 VDC inputs together to prevent an alarm condition when only one input feed wire is connected. To provide split shelf powering:

- 1 Ensure that the ground connection is in place.
- 2 Remove the four-position jumper (refer to [Figure 7 on page 28](#)) and discard.
- 3 Connect a wire from the –48A-LOW terminal of TB1 (see [Figure 8](#)) to the CO A battery supply at the fuse panel.
- 4 Connect a wire from the –48B-HIGH terminal of TB1 to the CO B battery supply at the fuse panel.
- 5 Connect a wire from the Battery Return terminal in position 5 of TB1 to the CO A battery return at the fuse panel.
- 6 Use a short jumper wire to connect the Battery Return terminal in position 6 of TB1 to the CO B battery return at the fuse panel.
- 7 Use a short jumper wire to connect the –48 A-LOW and –48 B-LOW terminals of TB1. Make this connection at the top of the terminal block as shown in [Figure 8](#).
- 8 Use a short jumper wire to connect the –48A-HIGH and –48B-HIGH terminals of TB1. Make this connection at the top of the terminal block as shown in [Figure 8](#).

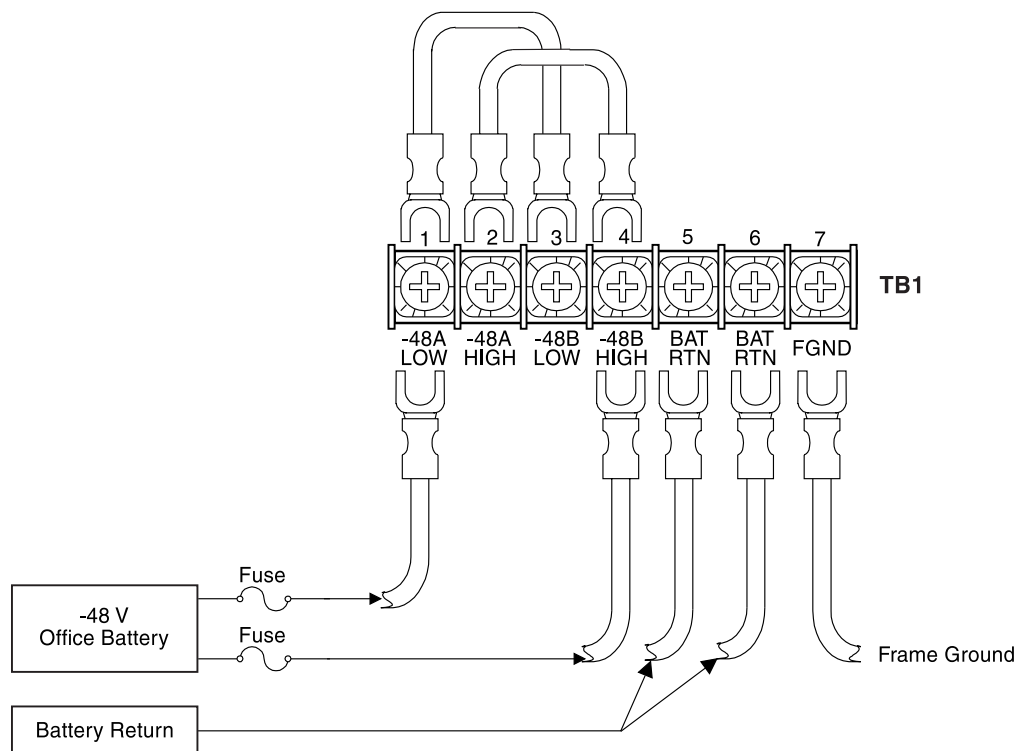

**Figure 8.** Split-Shelf Wiring

## Single Source Powering

In this configuration, the entire shelf is powered from a single source of -48 Vdc power fused according to [Table 18 on page 24](#) and [Table 19 on page 25](#).

A four-position jumper is in place on the TB1 block. This jumper shorts all of the 48 VDC inputs together to prevent an alarm condition when only one input feed wire is connected. To provide single source powering:

- 1 Ensure that the ground connection is in place.
- 2 Connect a wire from the -48A-LOW terminal at TB1 ([Figure 9](#)) to the CO battery supply at the fuse panel.
- 3 Connect a wire from the Battery Return terminal in position 6 of TB1 to the battery return of the CO battery supply at the fuse panel.
- 4 The four-position jumper from the -48A-LOW terminal of TB1 to the -48B-HIGH terminal of TB1 should be installed as shown in [Figure 9](#).

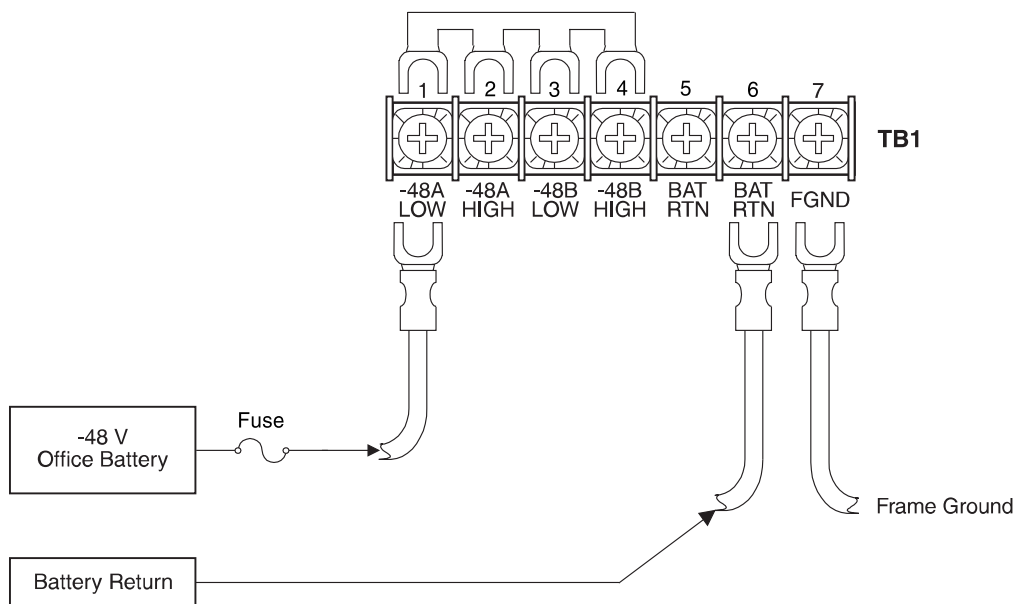

**Figure 9.** Single Source Power Wiring



If the -48HIGH and the -48LOW terminals are not jumpered, the COLU power LED blinks because one of the power rails is missing.



### Audible and Visual Alarm Connections

Use a wire-wrap tool to terminate the alarm leads from the external alarm equipment on the alarm relay wire-wrap field. See Figure 10 for the location of the alarm relay wire-wrap field. Table 20 on page 32 shows the layout of the wire-wrap pins on the shelf backplane.

If a remote ACO switch is to be wired, refer to the “External ACO Connection” on page 44 for the wire-wrap pin location.

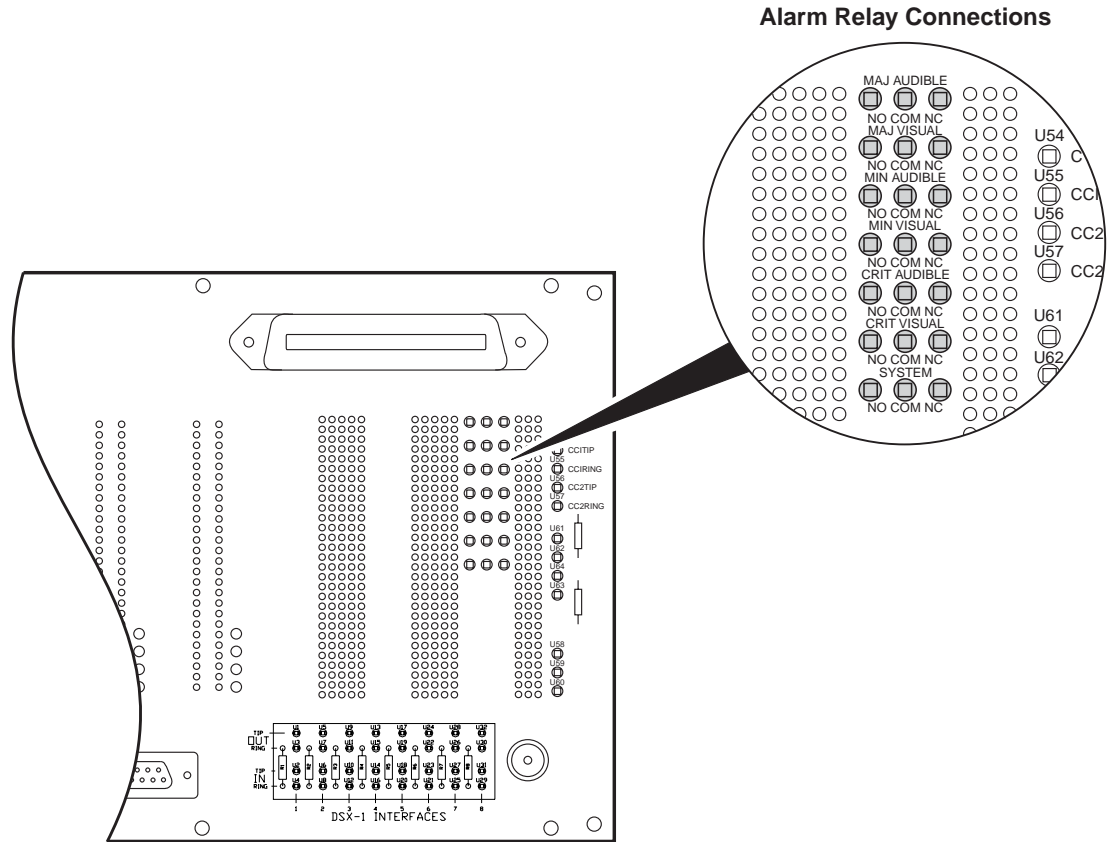

Figure 10. Connecting the Alarm Relays

**Table 20. Alarm Terminations**

Posts	Contact Post NO*	Contact Post COM <sup>(a)</sup>	Contact Post NC <sup>(a)</sup>	FUNCTION†
SYSTEM	1	2	3	System indicates a critical, major or minor alarm is active on the COT shelf.
CRIT VISUAL	4	5	6	Indicates a critical alarm. Connect this relay to the critical alarm visual indicator of the CO alarm system.
CRIT AUDIBLE	7	8	9	Indicates a critical alarm. The alarm can be silenced using the ACO button. Connect this relay to the critical alarm audible indicator of the CO alarm system.
MIN VISUAL	10	11	12	Indicates a minor alarm. Connect this relay to the minor alarm visual indicator of the CO alarm system.
MIN AUDIBLE	13	14	15	Indicates a minor alarm. The alarm can be silenced using the ACO button. Connect this relay to the minor alarm audible indicator of the CO alarm system.
MAJ VISUAL	16	17	18	Indicates a major alarm. Connect this relay to the major alarm visual indicator of the CO alarm system.
MAJ AUDIBLE	19	20	21	Indicates a major alarm. The alarm can be silenced using the ACO button. Connect this relay to the major alarm audible indicator of the CO alarm system.

(\*) For the relay contacts, NO is normally opened, NC is normally closed, and COM is common.

(†) All relays provide form "C" contacts.

## Subscriber Connections From CO

Tables 21 through 23 show the assignment of subscriber services from each card slot location to the Telco connectors. Subscriber lines from the CO are connected to the COT shelf by way of 50-pin Telco connectors (P1, P2, P3, and P5). Tables 24 through 27 list the Telco connector pinouts.



**Tables 21 through 27 apply when universal PG-Plus COLUs are installed in the COT shelf.**

**Table 21.** P1 Tip and Ring Pin Assignments

COT Shelf Cardslot	COLU Type					COT Shelf Connector Assignments	
	PLL-720	PLL-721	PLL-722	PLL-723	PLL-724	Tip	Ring
LU 1	POTS1	POTS1	POTS1		POTS	P1-26	P1-1
	POTS2	POTS2	POTS2			P1-27	P1-2
	POTS3	POTS3	POTS3			P1-28	P1-3
	POTS4	POTS4	ISDN	ISDN1	ISDN	P1-29	P1-4
		POTS5		ISDN2		P1-30	P1-5
		POTS6				P1-31	P1-6
LU 2	POTS1	POTS1	POTS1		POTS	P1-32	P1-7
	POTS2	POTS2	POTS2			P1-33	P1-8
	POTS3	POTS3	POTS3			P1-34	P1-9
	POTS4	POTS4	ISDN	ISDN1	ISDN	P1-35	P1-10
		POTS5		ISDN2		P1-36	P1-11
		POTS6				P1-37	P1-12
LU 3	POTS1	POTS1	POTS1		POTS	P1-38	P1-13
	POTS2	POTS2	POTS2			P1-39	P1-14
	POTS3	POTS3	POTS3			P1-40	P1-15
	POTS4	POTS4	ISDN	ISDN1	ISDN	P1-41	P1-16
		POTS5		ISDN2		P1-42	P1-17
		POTS6				P1-43	P1-18
LU 4	POTS1	POTS1	POTS1		POTS	P1-44	P1-19
	POTS2	POTS2	POTS2			P1-45	P1-20
	POTS3	POTS3	POTS3			P1-46	P1-21
	POTS4	POTS4	ISDN	ISDN1	ISDN	P1-47	P1-22
		POTS5		ISDN2		P1-48	P1-23
		POTS6				P1-49	P1-24

**Table 22.** P2 Tip and Ring Pin Assignments

COT Shelf Cardslot	COLU Type					COT Shelf Connector Assignments	
	PLL-720	PLL-721	PLL-722	PLL-723	PLL-724	Tip	Ring
LU 5	POTS1	POTS1	POTS1		POTS	P2-26	P2-1
	POTS2	POTS2	POTS2			P2-27	P2-2
	POTS3	POTS3	POTS3			P2-28	P2-3
	POTS4	POTS4	ISDN	ISDN1	ISDN	P2-29	P2-4
		POTS5		ISDN2		P2-30	P2-5
		POTS6				P2-31	P2-6
LU 6	POTS1	POTS1	POTS1		POTS	P2-32	P2-7
	POTS2	POTS2	POTS2			P2-33	P2-8
	POTS3	POTS3	POTS3			P2-34	P2-9
	POTS4	POTS4	ISDN	ISDN1	ISDN	P2-35	P2-10
		POTS5		ISDN2		P2-36	P2-11
		POTS6				P2-37	P2-12
LU 7	POTS1	POTS1	POTS1		POTS	P2-38	P2-13
	POTS2	POTS2	POTS2			P2-39	P2-14
	POTS3	POTS3	POTS3			P2-40	P2-15
	POTS4	POTS4	ISDN	ISDN1	ISDN	P2-41	P2-16
		POTS5		ISDN2		P2-42	P2-17
		POTS6				P2-43	P2-18
LU 8	POTS1	POTS1	POTS1		POTS	P2-44	P2-19
	POTS2	POTS2	POTS2			P2-45	P2-20
	POTS3	POTS3	POTS3			P2-46	P2-21
	POTS4	POTS4	ISDN	ISDN1	ISDN	P2-47	P2-22
		POTS5		ISDN2		P2-48	P2-23
		POTS6				P2-49	P2-24

**Table 23. P3 Tip and Ring Pin Assignments**

COT Shelf Cardslot	COLU Type					COT Shelf Connector Assignments	
	PLL-720	PLL-721	PLL-722	PLL-723	PLL-724	Tip	Ring
<b>LU 9</b>	POTS1	POTS1	POTS1		POTS	P3-26	P3-1
	POTS2	POTS2	POTS2			P3-27	P3-2
	POTS3	POTS3	POTS3			P3-28	P3-3
	POTS4	POTS4	ISDN	ISDN1	ISDN	P3-29	P3-4
		POTS5		ISDN2		P3-30	P3-5
		POTS6				P3-31	P3-6
<b>LU 10</b>	POTS1	POTS1	POTS1		POTS	P3-32	P3-7
	POTS2	POTS2	POTS2			P3-33	P3-8
	POTS3	POTS3	POTS3			P3-34	P3-9
	POTS4	POTS4	ISDN	ISDN1	ISDN	P3-35	P3-10
		POTS5		ISDN2		P3-36	P3-11
		POTS6				P3-37	P3-12
<b>LU 11</b>	POTS1	POTS1	POTS1		POTS	P3-38	P3-13
	POTS2	POTS2	POTS2			P3-39	P3-14
	POTS3	POTS3	POTS3			P3-40	P3-15
	POTS4	POTS4	ISDN	ISDN1	ISDN	P3-41	P3-16
		POTS5		ISDN2		P3-42	P3-17
		POTS6				P3-43	P3-18
<b>LU 12</b>	POTS1	POTS1	POTS1		POTS	P3-44	P3-19
	POTS2	POTS2	POTS2			P3-45	P3-20
	POTS3	POTS3	POTS3			P3-46	P3-21
	POTS4	POTS4	ISDN	ISDN1	ISDN	P3-47	P3-22
		POTS5		ISDN2		P3-48	P3-23
		POTS6				P3-49	P3-24

**Table 24.** *P1 Telco Connector*

<b>Pin #</b>	<b>Assignment</b>	<b>Assignment</b>	<b>Pin #</b>
1	RING1	TIP1	26
2	RING2	TIP2	27
3	RING3	TIP3	28
4	RING4	TIP4	29
5	RING5	TIP5	30
6	RING6	TIP6	31
7	RING7	TIP7	32
8	RING8	TIP8	33
9	RING9	TIP9	34
10	RING10	TIP10	35
11	RING11	TIP11	36
12	RING12	TIP12	37
13	RING13	TIP13	38
14	RING14	TIP14	39
15	RING15	TIP15	40
16	RING16	TIP16	41
17	RING17	TIP17	42
18	RING18	TIP18	43
19	RING19	TIP19	44
20	RING20	TIP20	45
21	RING21	TIP21	46
22	RING22	TIP22	47
23	RING23	TIP23	48
24	RING24	TIP24	49
25	FGND	FGND	50

**Table 25.** *P2 Telco Connector*

<b>Pin #</b>	<b>Assignment</b>	<b>Assignment</b>	<b>Pin #</b>
1	RING25	TIP25	26
2	RING26	TIP26	27
3	RING27	TIP27	28
4	RING28	TIP28	29
5	RING29	TIP29	30
6	RING30	TIP30	31
7	RING31	TIP31	32
8	RING32	TIP32	33
9	RING33	TIP33	34
10	RING34	TIP34	35
11	RING35	TIP35	36
12	RING36	TIP36	37
13	RING37	TIP37	38
14	RING38	TIP38	39
15	RING39	TIP39	40
16	RING40	TIP40	41
17	RING41	TIP41	42
18	RING42	TIP42	43
19	RING43	TIP43	44
20	RING44	TIP44	45
21	RING45	TIP45	46
22	RING46	TIP46	47
23	RING47	TIP47	48
24	RING48	TIP48	49
25	FGND	FGND	50

**Table 26.** *P3 Telco Connector*

<b>Pin #</b>	<b>Assignment</b>	<b>Assignment</b>	<b>Pin #</b>
1	RING49	TIP49	26
2	RING50	TIP50	27
3	RING51	TIP51	28
4	RING52	TIP52	29
5	RING53	TIP53	30
6	RING54	TIP54	31
7	RING55	TIP55	32
8	RING56	TIP56	33
9	RING57	TIP57	34
10	RING58	TIP58	35
11	RING59	TIP59	36
12	RING60	TIP60	37
13	RING61	TIP61	38
14	RING62	TIP62	39
15	RING63	TIP63	40
16	RING64	TIP64	41
17	RING65	TIP65	42
18	RING66	TIP66	43
19	RING67	TIP67	44
20	RING68	TIP68	45
21	RING69	TIP69	46
22	RING70	TIP70	47
23	RING71	TIP71	48
24	RING72	TIP72	49
25	FGND	FGND	50



**Table 27.** *P5 Telco Connector*

<b>Pin #</b>	<b>Assignment</b>	<b>Assignment</b>	<b>Pin #</b>
1	4WTXR1	4WTXT1	25
2	4WRXR1	4WRXT1	26
3	4WTXR2	4WTXT2	27
4	4WRXR2	4WRXT2	28
5	4WTXR3	4WTXT3	29
6	4WRXR3	4WRXT3	30
7	4WTXR4	4WTXT4	31
8	4WRXR4	4WRXT4	32
9	4WTXR5	4WTXT5	33
10	4WRXR5	4WRXT5	34
11	4WTXR6	4WTXT6	35
12	4WRXR6	4WRXT6	36
13	4WTXR7	4WTXT7	37
14	4WRXR7	4WRXT7	38
15	4WTXR8	4WTXT8	39
16	4WRXR8	4WRXT8	40
17	4WTXR9	4WTXT9	41
18	4WRXR9	4WRXT9	42
19	4WTXR10	4WTXT10	43
20	4WRXR10	4WRXT10	44
21	4WTXR11	4WTXT11	45
22	4WRXR11	4WRXT11	46
23	4WTXR12	4WTXT12	47
24	4WRXR12	4WRXT12	48

## Composite Clock Connections



**This step is required only if provisioning for DDS circuits.**

Termination resistors (TERM1 and TERM2) are located below the composite clock wire-wrap pins to provide the correct termination on the composite clock. To connect the clock leads from the Central Office Timing Source Generator to the COT shelf backplane:

- 1 Connect the first clock pair from the timing source generator to the CC1TIP and CC1RING
- 2 Connect the second clock pair from the timing source generator to the CC2TIP and CC2RING



**When connecting multiple COT shelves, you can wire-wrap pins on the backplane to allow up to seven shelves in daisy-chain fashion.**

- 3 From the COT shelf at the end of the daisy-chain, connect CC1TIP to one terminal of TERM 1, and CC1RING to the other terminal on TERM 1 ([Figure 10](#)).
- 4 From the COT shelf at the end of the daisy-chain, connect CC2TIP to one terminal of TERM 2, and CC2RING to the other terminal on TERM 2 ([Figure 10](#)) if a second composite clock source is to be used.

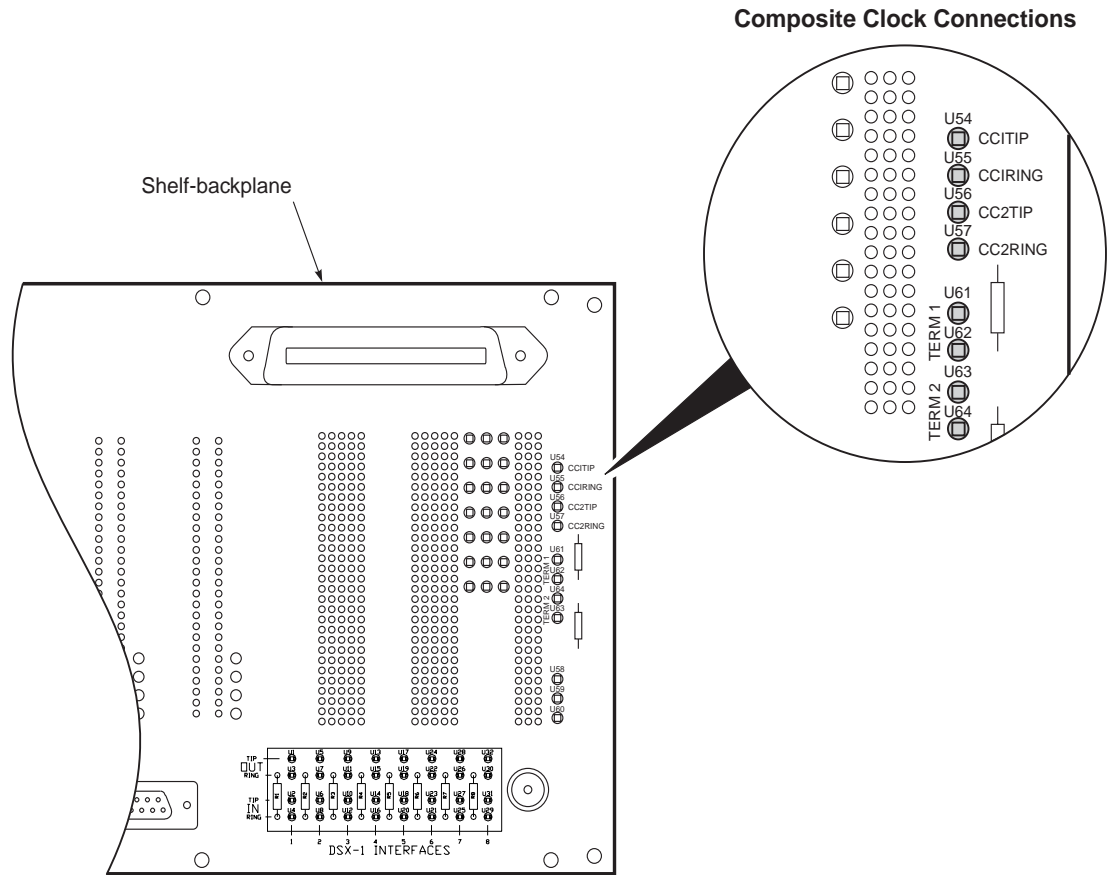

**Figure 11.** Connecting the Composite Clock

## HDSL Wiring

J4 - J15 on the PCS-718 backplane correspond to COLU slot numbers LU1 to LU12. **Figure 12** shows HDSL connections for J4 and J5. The wire-wrap pin labels for J4 - J15 correspond to the COLU slot number (LU1, LU2, etc.). In **Figure 12**, DSL\_A-1 is for the primary HDSL connection to COLU slot 1 (LU1). For COLU slot 12 (LU12), the wire-wrap pin label would read DSL\_A-12.

To make the wire-wrap terminations on the HDSL using one pair leads:

- 1 Use a wire-wrap tool to terminate HDSL pair #1 onto the T (Tip) and R (Ring) wire-wrap pins labeled DSL\_A-1.
- 2 Terminate the remainder of the required HDSL pairs onto the T and R wire-wrap pins on terminals DSL\_A-2 (LU2) through DSL\_A-12 (LU12):

To make the wire-wrap terminations on the HDSL using two pair leads:

- 1 Use a wire-wrap tool to terminate HDSL pair #1 onto the T (Tip) and R (Ring) wire-wrap pins labeled DSL\_A-1.
- 2 Use a wire-wrap tool to terminate HDSL pair #2 onto the T (Tip) and R (Ring) wire-wrap pins labeled DSL\_B-1.
- 3 Terminate the remainder of the required HDSL pairs onto the T and R wire-wrap pins on terminals DSL\_A-2 (LU2) through DSL\_A-12 (LU12) and DSL\_B-2 (LU2) through DSL\_B-12 (LU12).

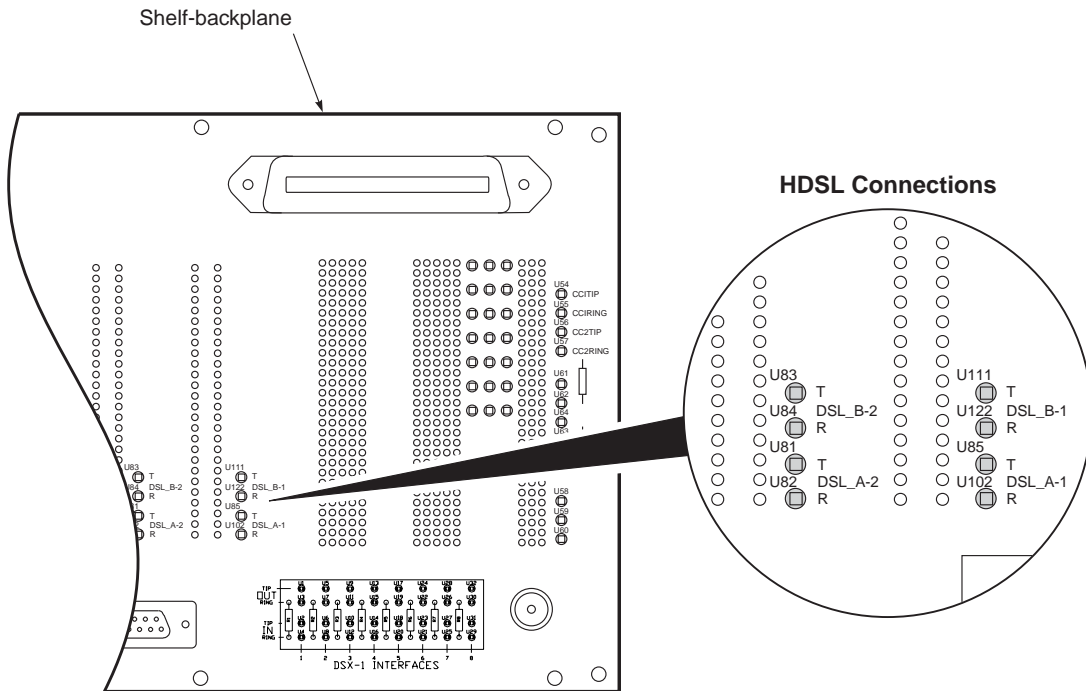

**Figure 12.** Connecting the HDSL Pairs

Table 28 shows the assignment of each card slot location to the HDSL terminations on the COT shelf backplane.

**Table 28.** PCS-718 HDSL Connections

COT Shelf		Central Office Line Unit		
Card Slot	HDSL Terminations	2 x 2 Ch. ICOLU	4, 6 Ch. ICOLU	24 Ch. ICOLU
LU 1	DSL_A – 1	System 1 – HDSL	System 1 – HDSL	System 1 – Pwr 1
	DSL_B – 1	System 2 – HDSL	(not used)	System 1 – Pwr 2
LU 2	DSL_A – 2	System 3 – HDSL	System 2 – HDSL	System 1 – HDSL 1
	DSL_B – 2	System 4 – HDSL	(not used)	System 1 – HDSL 2
LU 3	DSL_A – 3	System 5 – HDSL	System 3 – HDSL	System 2 – Pwr 1
	DSL_B – 3	System 6 – HDSL	(not used)	System 2 – Pwr 2
LU 4	DSL_A – 4	System 7 – HDSL	System 4 – HDSL	System 2 – HDSL 1
	DSL_B – 4	System 8 – HDSL	(not used)	System 2 – HDSL 2
LU 5	DSL_A – 5	System 9 – HDSL	System 5 – HDSL	System 3 – Pwr 1
	DSL_B – 5	System 10 – HDSL	(not used)	System 3 – Pwr 2
LU 6	DSL_A – 6	System 11 – HDSL	System 6 – HDSL	System 3 – HDSL 1
	DSL_B – 6	System 12 – HDSL	(not used)	System 3 – HDSL 2
LU 7	DSL_A – 7	System 13 – HDSL	System 7 – HDSL	System 4 – Pwr 1
	DSL_B – 7	System 14 – HDSL	(not used)	System 4 – Pwr 2
LU 8	DSL_A – 8	System 15 – HDSL	System 8 – HDSL	System 4 – HDSL 1
	DSL_B – 8	System 16 – HDSL	(not used)	System 4 – HDSL 2
LU 9	DSL_A – 9	System 17 – HDSL	System 9 – HDSL	System 5 – Pwr 1
	DSL_B – 9	System 18 – HDSL	(not used)	System 5 – Pwr 2
LU 10	DSL_A – 10	System 19 – HDSL	System 10 – HDSL	System 5 – HDSL 1
	DSL_B – 10	System 20 – HDSL	(not used)	System 5 – HDSL 2
LU 11	DSL_A – 11	System 21 – HDSL	System 11 – HDSL	System 6 – Pwr 1
	DSL_B – 11	System 22 – HDSL	(not used)	System 6 – Pwr 2
LU 12	DSL_A – 12	System 23 – HDSL	System 12 – HDSL	System 6 – HDSL 1
	DSL_B – 12	System 24 – HDSL	(not used)	System 6 – HDSL 2

## External ACO Connection

The ACO connection is located to the left handed side of the pin labeled EXT ACO as shown in [Figure 13](#). To control the ACO remotely, connect the ACO to GROUND through a Normally Open, momentary contact switch.

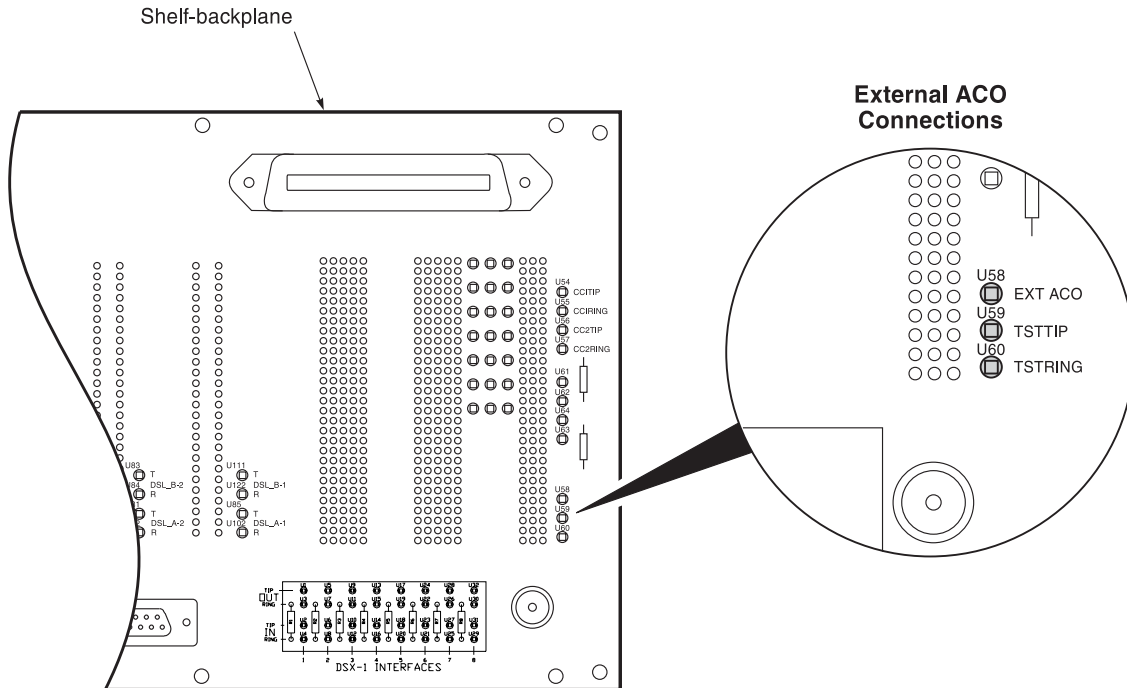

**Figure 13.** Connecting the External ACO Switch

## TURN-UP AND TEST



The following steps should be performed before any circuit cards are installed in the COT shelf.

- 1 Verify correct termination of all the HDSL lines on the wire-wrap field on the shelf backplane.
- 2 Install the fuse(s) in the CO fuse panel for the circuits providing  $-48$  Vdc power to the COT shelf. Observe that the fuses hold when installed.
- 3 Verify that there is between  $-42$  Vdc and  $-56$  Vdc between each of the  $-48$  Vdc terminals and GND on TB1 on the COT shelf backplane.
- 4 Measure the dc voltage across the HDSL terminations. Ensure that there is  $0$  Vdc between the Tip and Ring, Tip and Ground, and Ring and Ground of each HDSL circuit terminated on the shelf.
- 5 Measure the resistance across the HDSL terminations. Ensure that there is at least  $100$  k $\Omega$  of resistance between the Tip and Ring, Tip and Ground, and Ring and Ground of each HDSL circuit terminated on the shelf.
- 6 Replace the clear Plexiglas cover on the back of the COT shelf.

# PRODUCT SUPPORT

## TECHNICAL SUPPORT

Technical Assistance is available 24 hours a day, 7 days a week by the contacting Customer Service Engineering group at:

Telephone: 800.366.3891  
The 800 telephone support line is toll-free in the U.S. and Canada.

Email: [wsd\\_support@adc.com](mailto:wsd_support@adc.com)

Knowledge Base: [http://adc.com/Knowledge\\_Base/index.jsp](http://adc.com/Knowledge_Base/index.jsp)

Web: [www.adc.com](http://www.adc.com)

## LIMITED WARRANTY

Product warranty is determined by your service agreement. Refer to the ADC Warranty/Software Handbook for additional information, or contact your sales representative or Customer Service for details.

## RETURNS

To return equipment to ADC:

- 1 Locate the number of the purchase order under which the equipment was purchased. To obtain a return authorization number, you need to provide the original purchase order number to ADC's Return Material Authorization (RMA) Department.
- 2 Call or write ADC's RMA Department to ask for an RMA number and any additional instructions. Use the telephone number, fax number or email address listed below:
  - Telephone: 800.366.3891
  - Email Address: [rma@ADC.com](mailto:rma@ADC.com)
- 3 Include the following information, in writing, along with the equipment you are returning:
  - Company name and address.
  - Contact name and telephone number.
  - The shipping address to which ADC should return the repaired equipment.
  - The original purchase order number.
  - A description of the equipment that includes the model and part number of each unit being returned, as well as the number of units that you are returning.
  - The reason for the return. For example:
    - The equipment needs an ECO/ECN upgrade.
    - The equipment is defective.



**If the equipment is defective, please tell us what you observed just before the equipment malfunctioned. Be as detailed in your description as possible.**

If there is another reason for returning the equipment, please let us know so we can determine how best to help you.

- 4 Pack the equipment in a shipping carton.
- 5 Write ADC's address and the RMA Number you received from the RMA Department clearly on the outside of the carton and return to:

ADC DSL Systems, Inc.  
14352 Franklin Ave.  
Tustin, CA 92780-7013

Attention: **RMA (Number)**



**All shipments are to be returned prepaid. ADC will not accept any collect shipments.**



## **FCC CLASS A COMPLIANCE**

This equipment has been tested and found to comply with the limits for a Class A digital device, pursuant to Part 15 of the FCC rules. These limits are designed to provide reasonable protection against harmful interference when the equipment is operated in a commercial environment. This equipment generates, uses and can radiate radio frequency energy and, if not installed and used in accordance with the instruction manual, may cause harmful interference to radio communications. Operation of this equipment in a residential area is likely to cause harmful interference in which case the user will be required to correct the interference at his own expense.

## **Modifications**

The FCC requires the user to be notified that any changes or modifications made to this device that are not expressly approved by ADC Technologies, Inc. voids the user's warranty.

All wiring external to the product(s) should follow the provisions of the current edition of the National Electrical Code.

---

# ACRONYMS

<b>ACO</b>	Alarm Cut Off
<b>AWG</b>	American Wire Gauge
<b>CO</b>	Central Office
<b>COLU</b>	Central Office Line Unit
<b>COT</b>	Central Office Terminal
<b>DDS</b>	Digital Data Service
<b>DS1</b>	Digital Signal One
<b>DTE</b>	Data Terminal Equipment
<b>ESD</b>	Electrostatic Discharge
<b>FICOLU</b>	PG-Flex Integrated Central Office Line Unit
<b>HDSL</b>	High-bit-rate Digital Subscriber Line
<b>LED</b>	Light-Emitting Diode
<b>MLT</b>	Mechanized Loop Testing
<b>NEBS</b>	Network Equipment Building Standard
<b>PAU</b>	PG-Plus Alarm Unit
<b>PMU</b>	PG-Plus Management Unit
<b>PMX</b>	PG-Plus Multiplexer Unit.
<b>POTS</b>	Plain Old Telephone Service
<b>PRL</b>	PG-Plus Remote Line unit
<b>RLU</b>	Remote Line Unit
<b>RMA</b>	Return Materials Authorization
<b>RT</b>	Remote Terminal



---

**World Headquarters:**

ADC Telecommunications, Inc.  
12501 Whitewater Drive  
Minnetonka, Minnesota USA 55343

**For Technical Assistance:**

800.366.3891



1251780

---