

PG-PLUS

23-INCH CENTRAL OFFICE TERMINAL SHELF

Model	List Number	Part Number	CLEI Code
PCS-719	1	150-1619-01	S9MTAB0ARA

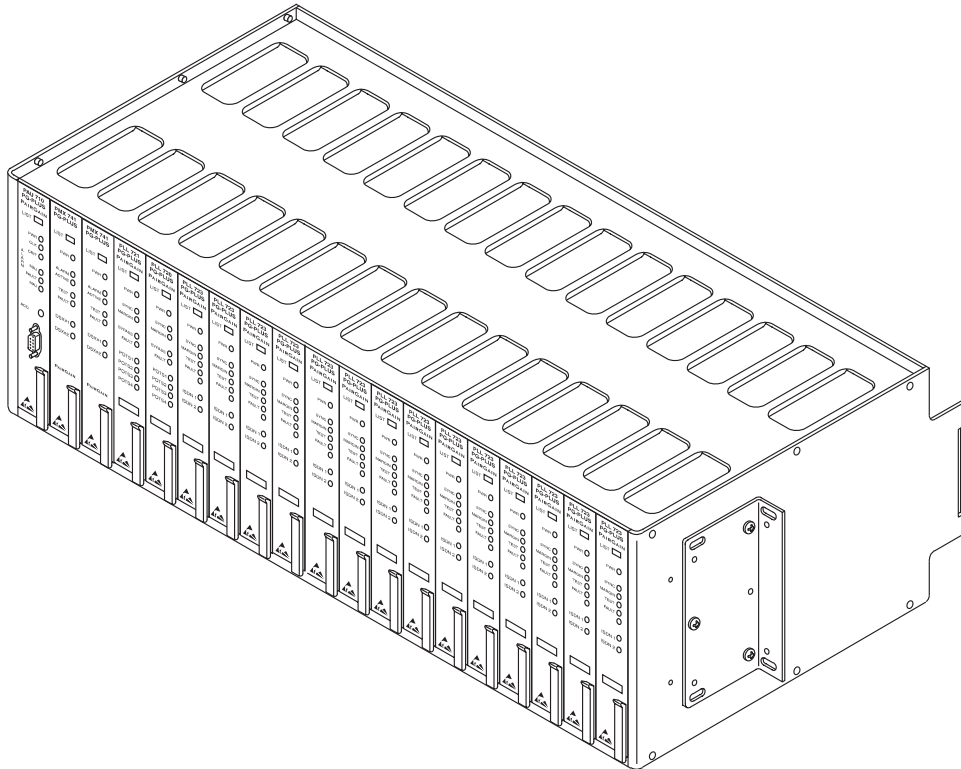

PAIRGAIN TECHNOLOGIES, INC.
ENGINEERING SERVICES TECHNICAL PRACTICE
SECTION 950-719-100-03

Revision History of this practice.
Revision 03—September 2, 1997
A) Added Pin Assignment Table
B) Corrected Connection process

©Copyright 1997 PairGain® Technologies, Inc.

PairGain is a registered trademark, and *PG-Plus* is a trademark of PairGain Technologies, Inc.

Other product names mentioned in this manual are used for identification purposes only and may be trademarks and/or registered trademarks of their respective Information contained in this document is company private to PairGain Technologies, Inc. and shall not be modified, used, copied, reproduced or disclosed in whole or in part without the written consent of PairGain.

TABLE OF CONTENTS

Using This Technical Practice.....	iv
Inspecting Your Shipment.....	iv
PCS-719 Overview	1
Description and Features	1
Theory of Operation	2
Data Channel Overview	2
Serial Communications Bus	3
Composite Clock Signals	3
Test Bus	3
Communication Requests	3
Backplane Connections	4
Power	5
COLU HDSL	5
Two-Wire Subscriber Pairs	5
Four-Wire Pairs	5
COLU Edge Card Connectors	6
Alarm Cutoff	13
Alarm Contacts	14
OS Interface	14
LAN Interface	14
DSX1 Connections	15
PAU/PMU Connector	15
PMX Connector	16
Specifications	18
Installation and Test	18
Required Tools and Test Equipment	18
Power	18
Mounting	18
Wiring Access	19
Alarm Leads	19
HDSL Lines	19
Subscriber Lines	19
Connections	19
Ground Connections	19
Power Connections	20
Redundant-Shelf Powering	21
Split-Shelf Powering	22
Single-Source Powering	23
Audible and Visual Alarm Connections	24
Subscriber Connections From CO	25
Composite Clock Connections	32
HDSL Wiring	33
External ACO Connection	34
Turn-Up and Test	34
Product Support	35
Technical Support	35
Warranty	35
FCC Compliance	35
Modifications	36
Abbreviations	36

USING THIS TECHNICAL PRACTICE

Three types of messages, identified by icons, appear in the text:



A note informs you of special circumstances.



A caution indicates the possibility of equipment damage.



A warning indicates the possibility of personal injury.

INSPECTING YOUR SHIPMENT

Upon receipt of the equipment:

- Unpack each container and visually inspect it for signs of damage. If the equipment has been damaged in transit, immediately report the extent of damage to the transportation company and to PairGain. Order replacement equipment, if necessary.
- Check the packing list to ensure complete and accurate shipment of each listed item. If the shipment is short or irregular, contact PairGain as described in the Warranty. If you must store the equipment for a prolonged period, store the equipment in its original container.

PCS-719 OVERVIEW

This practice describes the PairGain PG-Plus PCS-719 List 1B Central Office Terminal 23-inch shelf (COTS) which supports up to sixteen PG-Plus subscriber carrier systems.

DESCRIPTION AND FEATURES

The PCS-719 provides convenient mounting of COTS Plus Alarm Unit (PAUs) and Central Office Line Units (COLUs); and furnishes termination points for subscriber circuits, alarm, power, and metallic test access. All circuit boards are installed from the front of the shelf. Interconnections for PG-Plus units are located on the backplane at the rear of the shelf. The PCS-719 COTS accommodates the following PG-Plus units (see Figure 1):

- 16 COLUs
- Two Multiplexer Units (PMX)
- One PAU or one PG-Plus Management Unit (PMU) (interchangeable)

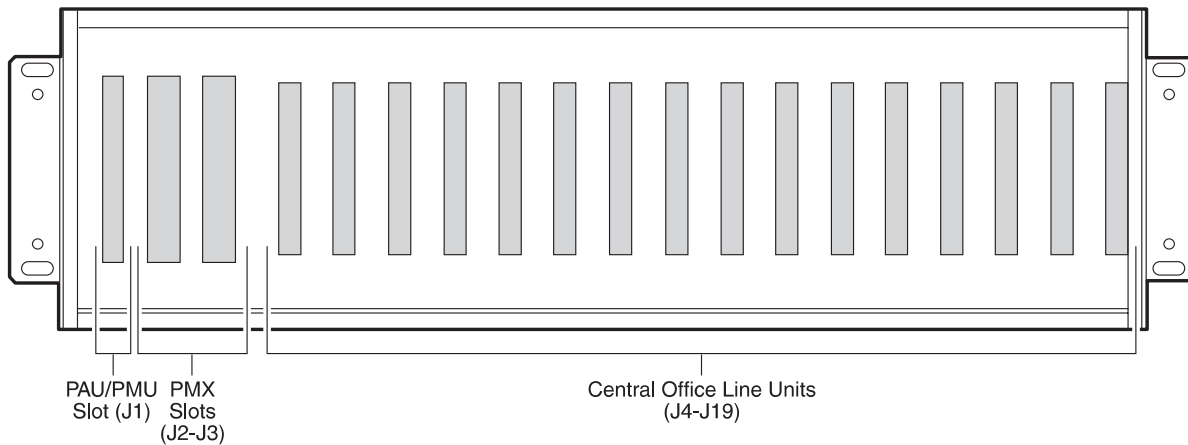

Figure 1 PCS-719 COTS

The COTS features:

- Wire-wrap connections for HDSL, alarm cutoff, and alarm relays
- Screw terminal connections for frame ground and Central Office (CO) battery
- DB-25 connector for network communications
- 64-pin Telco connector for four-wire service connections
- 50-pin Telco connector for CO lines

THEORY OF OPERATION

Data Channel Overview

The COTS backplane uses redundant Pulse Code Modulation (PCM) transmit and receive buses and Serial Communications buses (SCB) for data transfer and intra-shelf communications. Individual clock, data, and synchronization buses originate from the PMX cards and terminate at each COLU position. The COTS provides the signal connectivity and -48 V dc power distribution in the COTS. Figure 2 shows the backplane signal interconnection.

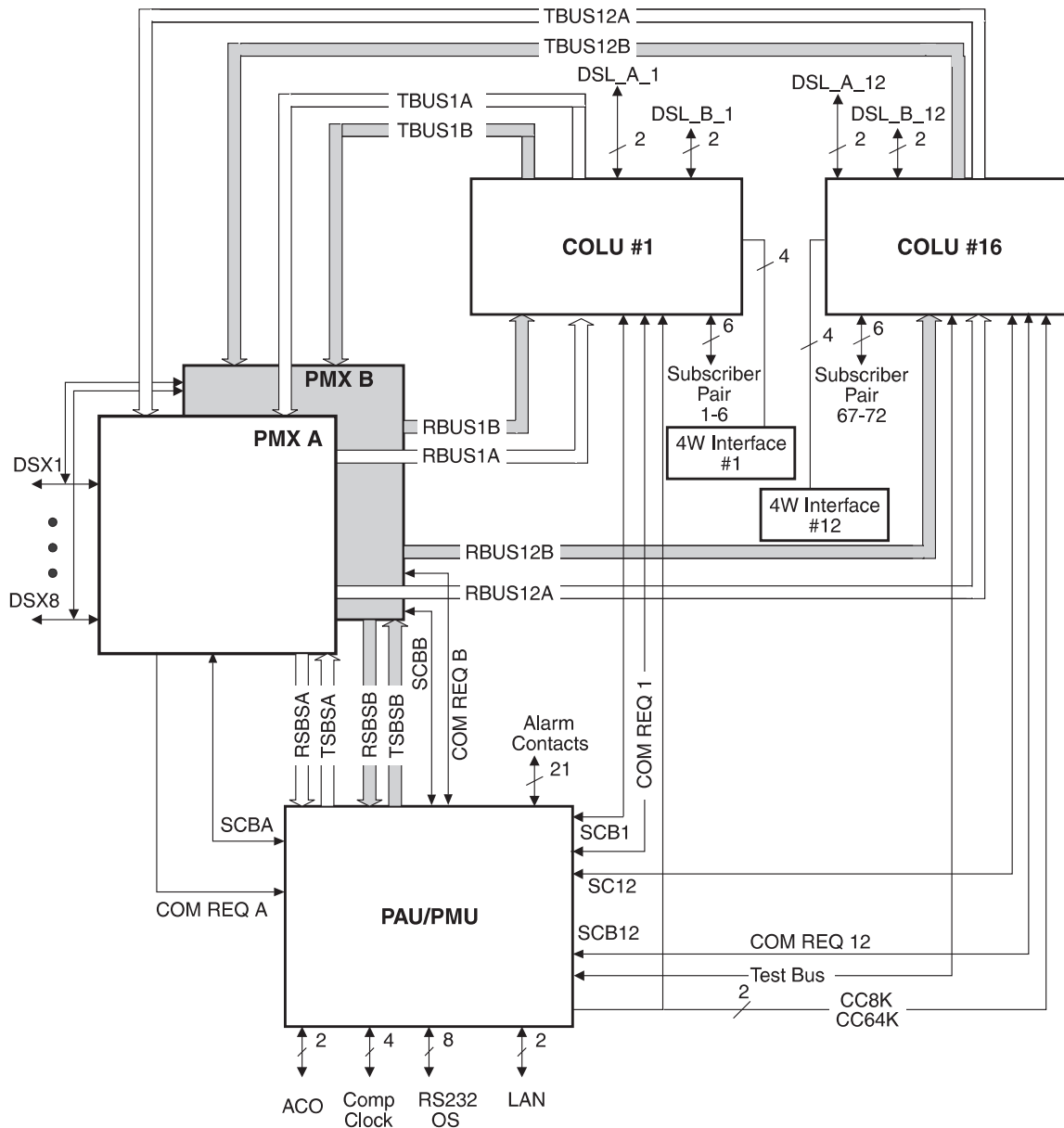

Figure 2 Backplane Signal Configuration

Serial Communications Bus

The Serial Communications Bus (SCB) provides the means for the PAU/PMU to communicate with all other boards in the COTS to allow:

- Software downloads
- Coordination of PMX equipment protection
- Generation of status, alarm, and performance reports through the PG-Plus Console menus
- Provisioning of each unit installed in the shelf through the PG-Plus Console menus

The serial bus operates in a master/slave polled environment with the PAU/PMU functioning as the SCB master. Each COLU position has its own SCB connection to avoid conflict. The SCB acts as the “card present” line to notify the PAU/PMU board that a line unit is present in the shelf. Figure 3 shows the communication line between the PAU/PMU and any COLU. If a COLU is not installed, the line is pulled high to notify the PAU/PMU that a line unit is not present and data should not be sent. When installed, each card pulls its line low.

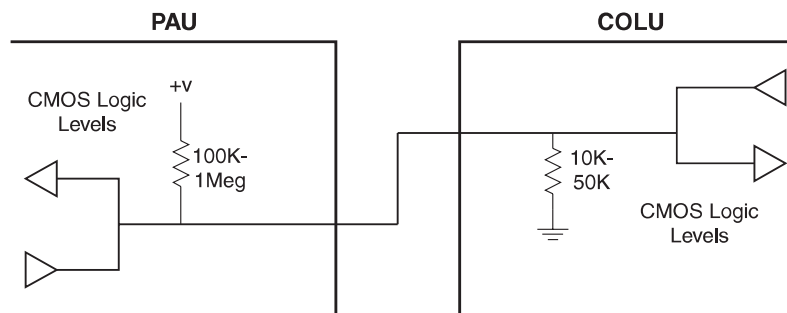

Figure 3 Communication Line Between PAU/PMU and COLU

Composite Clock Signals

Composite clock signals are a 64 kHz bipolar clock with 8 kHz bipolar violations. The 64 kHz clock and the 8 kHz violations define the bit and byte boundaries of DDS data as it is transferred within a CO. In support of the DDS interfaces, PG-Plus defines two composite clock interfaces at the PAU/PMU card slot. The PAU/PMU selects the clock and translates it into bit and byte clocks, which it then distributes to the COLUs. Wire-wrap pins on the backplane allow the composite clock source to be terminated or daisy-chained to another shelf.

Test Bus

The Test Bus provides a common Tip/Ring bus from the COLUs to the PAU/PMU. This bus allows the PAU/PMU to provide a resistive signature to any of the tested subscriber circuits.

Communication Requests

The COTS provides communication requests from each of the cards to the PAU/PMU slot. These signals are used by the COLU and PMX units to initiate communication with the PAU/PMU.

BACKPLANE CONNECTIONS

Each COTS supports the connection of up to sixteen COLUs, two PMX units and one PAU/PMU. The backplane of the PCS-719 COTS contains the connectors shown in Figure 4 and Table 1. Wiring external to the COTS should follow the provisions of the current edition of the National Electrical Code and applicable local codes.

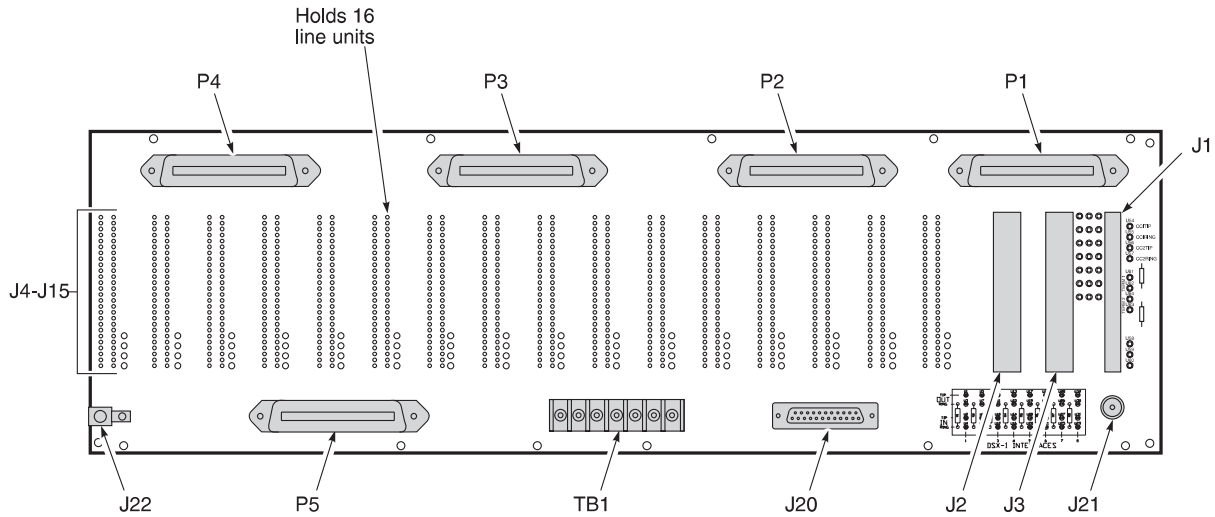

Figure 4 PCS-719 Shelf Backplane

The following sections identify each connector by type and function.



Information in Tables 2 through 20 can be used for diagnostic and troubleshooting procedures under the direction of an authorized PairGain technical support representative.

Table 1 Backplane Connectors

Connector	Description
J1	PAU or PMU connector
J2	PMX 1 connector
J3	PMX 2 connector
J4 - J19	COLU HDSL connectors
J20	DB-25 (RS-232) connector
J21	LAN connector
J22	Frame Ground
P1 - P4	Telco connectors for 2-wire interfaces
P5	Telco connector for 4-wire interfaces
TB1	Seven-position power-terminal strip

Power

The COTS backplane has a seven-position power-terminal strip (TB1) that provides connections for dual -48 V dc, common battery return, and frame ground to each of the card slots by way of screw terminals. The COTS can be wired for redundant powering, split-powering, or single-source powering depending upon requirements.

COLU HDSL

There are sixteen sets of wire-wrap HDSL interfaces on the COTS backplane, one for each COLU slot (J4 - J15 where J4 corresponds to slot LU1, and J19 corresponds to slot LU16). Each COLU slot is also equipped with a second pair of HDSL wire-wrap pins for future XDSL configurations.

Two-Wire Subscriber Pairs

A total of 96 two-wire subscriber pairs terminate at the Telco connectors (P1, P2, P3, and P4) on the PG-Plus COTS backplane. Six pairs route to each of the sixteen COLUs. See Tables 26 through 30 for P1, P2, P3, and P4 connector pinouts.

Four-Wire Pairs

The COTS provides a total of sixteen four-wire data interfaces for services such as DDS or Ethernet. They are segregated from the two-wire pairs on a separate Telco connector (P5, see Table 30). One four-wire connection is provided for each COLU slot.

COLU Edge Card Connectors

Tables 2 through 17 show the backplane connector pinouts for each COLU slot.

Table 2 COLU #1 (J4) Connector Pinouts

Pin #	Assignment	Assignment	Pin #
49	TIP1	RING1	50
47	TIP2	RING2	48
45	TIP3	RING3	46
43	TIP4	RING4	44
41	TIP5	RING5	42
39	TIP6	RING6	40
37	<BURN IN>	-	38
35	CC8KA	CC64KA	36
33	INTRPT1-	SCB1	34
31	RDATA1	RDATB1	32
29	CLKA1	CLKB1	30
27	RSIGA1	RSIGB1	28
25	FSYNCA1	FSYNCB1	26
23	TDATA1	TDATB1	24
21	TSIGA1	TSIGB1	22
19	TSTTIP	TSTRING	20
17	GND	GND	18
15	BATA_L	BATA_L	16
13	BATB_L	BATB_L	14
11	-	-	12
9	HTIPA1	HTIPB1	10
7	HRINGA1	HRINGB1	8
5	FGND	FGND	6
3	4WRXT1	4WRXR1	4
1	4WTXT1	4WTXR1	2

Table 3 COLU #2 (J5) Connector Pinouts

Pin #	Assignment	Assignment	Pin #
49	TIP7	RING7	50
47	TIP8	RING8	48
45	TIP9	RING9	46
43	TIP10	RING10	44
41	TIP11	RING11	42
39	TIP12	RING12	40
37	<BURN IN>	-	38
35	CC8KA	CC64KA	36
33	INTRPT2-	SCB2	34
31	RDATA2	RDATB2	32
29	CLKA2	CLKB2	30
27	RSIGA2	RSIGB2	28
25	FSYNCA2	FSYNCB2	26
23	TDATA2	TDATB2	24
21	TSIGA2	TSIGB2	22
19	TSTTIP	TSTRING	20
17	GND	GND	18
15	BATA_L	BATA_L	16
13	BATB_L	BATB_L	14
11	-	-	12
9	HTIPA2	HTIPB2	10
7	HRINGA2	HRINGB2	8
5	FGND	FGND	6
3	4WRXT2	4WRXR2	4
1	4WTXT2	4WTXR2	2

Table 4 COLU #3 (J6) Connector Pinouts

Pin #	Assignment	Assignment	Pin #
49	TIP13	RING13	50
47	TIP14	RING14	48
45	TIP15	RING15	46
43	TIP16	RING16	44
41	TIP17	RING17	42
39	TIP18	RING18	40
37	<BURN IN>	-	38
35	CC8KA	CC64KA	36
33	INTRPT3-	SCB3	34
31	RDATA3	RDATB3	32
29	CLKA3	CLKB3	30
27	RSIGA3	RSIGB3	28
25	FSYNCA3	FSYNCB3	26
23	TDATA3	TDATB3	24
21	TSIGA3	TSIGB3	22
19	TSTTIP	TSTRING	20
17	GND	GND	18
15	BATA_L	BATA_L	16
13	BATB_L	BATB_L	14
11	-	-	12
9	HTIPA3	HTIPB3	10
7	HRINGA3	HRINGB3	8
5	FGND	FGND	6
3	4WRXT3	4WRXR3	4
1	4WTXT3	4WTRX3	2

Table 5 COLU #4 (J7) Connector Pinouts

Pin #	Assignment	Assignment	Pin #
49	TIP19	RING19	50
47	TIP20	RING20	48
45	TIP21	RING21	46
43	TIP22	RING22	44
41	TIP23	RING23	42
39	TIP24	RING24	40
37	<BURN IN>	-	38
35	CC8KA	CC64KA	36
33	INTRPT4-	SCB4	34
31	RDATA4	RDATB4	32
29	CLKA4	CLKB4	30
27	RSIGA4	RSIGB4	28
25	FSYNCA4	FSYNCB4	26
23	TDATA4	TDATB4	24
21	TSIGA4	TSIGB4	22
19	TSTTIP	TSTRING	20
17	GND	GND	18
15	BATA_L	BATA_L	16
13	BATB_L	BATB_L	14
11	-	-	12
9	HTIPA4	HTIPB4	10
7	HRINGA4	HRINGB4	8
5	FGND	FGND	6
3	4WRXT4	4WRXR4	4
1	4WTXT4	4WTRX4	2

Table 6 COLU #5 (J8) Connector Pinouts

Pin #	Assignment	Assignment	Pin #
49	TIP25	RING25	50
47	TIP26	RING26	48
45	TIP27	RING27	46
43	TIP28	RING28	44
41	TIP29	RING29	42
39	TIP30	RING30	40
37	<BURN IN>	–	38
35	CC8KA	CC64KA	36
33	INTRPT5-	SCB5	34
31	RDATA5	RDATB5	32
29	CLKA5	CLKB5	30
27	RSIGA5	RSIGB5	28
25	FSYNCA5	FSYNCB5	26
23	TDATA5	TDATB5	24
21	TSIGA5	TSIGB5	22
19	TSTTIP	TSTRING	20
17	GND	GND	18
15	BATA_L	BATA_L	16
13	BATB_L	BATB_L	14
11	–	–	12
9	HTIPA5	HTIPB5	10
7	HRINGA5	HRINGB5	8
5	FGND	FGND	6
3	4WRXT5	4WRXR5	4
1	4WXT5	4WXR5	2

Table 7 COLU #6 (J9) Connector Pinouts

Pin #	Assignment	Assignment	Pin #
49	TIP31	RING31	50
47	TIP32	RING32	48
45	TIP33	RING33	46
43	TIP34	RING34	44
41	TIP35	RING35	42
39	TIP36	RING36	40
37	<BURN IN>	–	38
35	CC8KA	CC64KA	36
33	INTRPT6-	SCB6	34
31	RDATA6	RDATB6	32
29	CLKA6	CLKB6	30
27	RSIGA6	RSIGB6	28
25	FSYNCA6	FSYNCB6	26
23	TDATA6	TDATB6	24
21	TSIGA6	TSIGB6	22
19	TSTTIP	TSTRING	20
17	GND	GND	18
15	BATA_L	BATA_L	16
13	BATB_L	BATB_L	14
11	–	–	12
9	HTIPA6	HTIPB6	10
7	HRINGA6	HRINGB6	8
5	FGND	FGND	6
3	4WRXT6	4WRXR6	4
1	4WXT6	4WXR6	2

Table 8 COLU #7 (J10) Connector Pinouts

Pin #	Assignment	Assignment	Pin #
49	TIP37	RING37	50
47	TIP38	RING38	48
45	TIP39	RING39	46
43	TIP40	RING40	44
41	TIP41	RING41	42
39	TIP42	RING42	40
37	<BURN IN>	-	38
35	CC8KA	CC64KA	36
33	INTRPT7-	SCB7	34
31	RDATA7	RDATB7	32
29	CLKA7	CLKB7	30
27	RSIGA7	RSIGB7	28
25	FSYNCA7	FSYNCB7	26
23	TDATA7	TDATB7	24
21	TSIGA7	TSIGB7	22
19	TSTTIP	TSTRING	20
17	GND	GND	18
15	BATA_H	BATA_H	16
13	BATB_H	BATB_H	14
11	-	-	12
9	HTIPA7	HTIPB7	10
7	HRINGA7	HRINGB7	8
5	FGND	FGND	6
3	4WRXT7	4WRXR7	4
1	4WTXT7	4WTXR7	2

Table 9 COLU #8 (J11) Connector Pinouts

Pin #	Assignment	Assignment	Pin #
49	TIP43	RING43	50
47	TIP44	RING44	48
45	TIP45	RING45	46
43	TIP46	RING46	44
41	TIP47	RING47	42
39	TIP48	RING48	40
37	<BURN IN>	-	38
35	CC8KA	CC64KA	36
33	INTRPT8-	SCB8	34
31	RDATA8	RDATB8	32
29	CLKA8	CLKB8	30
27	RSIGA8	RSIGB8	28
25	FSYNCA8	FSYNCB8	26
23	TDATA8	TDATB8	24
21	TSIGA8	TSIGB8	22
19	TSTTIP	TSTRING	20
17	GND	GND	18
15	BATA_H	BATA_H	16
13	BATB_H	BATB_H	14
11	-	-	12
9	HTIPA8	HTIPB8	10
7	HRINGA8	HRINGB8	8
5	FGND	FGND	6
3	4WRXT8	4WRXR8	4
1	4WTXT8	4WTXR8	2

Table 10 COLU #9 (J12) Connector Pinouts

Pin #	Assignment	Assignment	Pin #
49	TIP49	RING49	50
47	TIP50	RING50	48
45	TIP51	RING51	46
43	TIP52	RING52	44
41	TIP53	RING53	42
39	TIP54	RING54	40
37	<BURN IN>	-	38
35	CC8KB	CC64KB	36
33	INTRPT9-	SCB9	34
31	RDATA9	RDATB9	32
29	CLKA9	CLKB9	30
27	RSIGA9	RSIGB9	28
25	FSYNCA9	FSYNCB9	26
23	TDATA9	TDATB9	24
21	TSIGA9	TSIGB9	22
19	TSTTIP	TSTRING	20
17	GND	GND	18
15	BATA_H	BATA_H	16
13	BATB_H	BATB_H	14
11	-	-	12
9	HTIPA9	HTIPB9	10
7	HRINGA9	HRINGB9	8
5	FGND	FGND	6
3	4WRXT9	4WRXR9	4
1	4WTXT9	4WTXR9	2

Table 11 COLU #10 (J13) Connector Pinouts

Pin #	Assignment	Assignment	Pin #
49	TIP55	RING55	50
47	TIP56	RING56	48
45	TIP57	RING57	46
43	TIP58	RING58	44
41	TIP59	RING59	42
39	TIP60	RING60	40
37	<BURN IN>	-	38
35	CC8KB	CC64KB	36
33	INTRPT10-	SCB10	34
31	RDATA10	RDATB10	32
29	CLKA10	CLKB10	30
27	RSIGA10	RSIGB10	28
25	FSYNCA10	FSYNCB10	26
23	TDATA10	TDATB10	24
21	TSIGA10	TSIGB10	22
19	TSTTIP	TSTRING	20
17	GND	GND	18
15	BATA_H	BATA_H	16
13	BATB_H	BATB_H	14
11	-	-	12
9	HTIPA10	HTIPB10	10
7	HRINGA10	HRINGB10	8
5	FGND	FGND	6
3	4WRXT10	4WRXR10	4
1	4WTXT10	4WTXR10	2

Table 12 COLU #11 (J14) Connector Pinouts

Pin #	Assignment	Assignment	Pin #
49	TIP61	RING61	50
47	TIP62	RING62	48
45	TIP63	RING63	46
43	TIP64	RING64	44
41	TIP65	RING65	42
39	TIP66	RING66	40
37	<BURN IN>	-	38
35	CC8KB	CC64KB	36
33	INTRPT11-	SCB11	34
31	RDATA11	RDATB11	32
29	CLKA11	CLKB11	30
27	RSIGA11	RSIGB11	28
25	FSYNCA11	FSYNCB11	26
23	TDATA11	TDATB11	24
21	TSIGA11	TSIGB11	22
19	TSTTIP	TSTRING	20
17	GND	GND	18
15	BATA_H	BATA_H	16
13	BATB_H	BATB_H	14
11	-	-	12
9	HTIPA11	HTIPB11	10
7	HRINGA11	HRINGB11	8
5	FGND	FGND	6
3	4WRXT11	4WRXR11	4
1	4WTXT11	4WTXR11	2

Table 13 COLU #12 (J15) Connector Pinouts

Pin #	Assignment	Assignment	Pin #
49	TIP67	RING67	50
47	TIP68	RING68	48
45	TIP69	RING69	46
43	TIP70	RING70	44
41	TIP71	RING71	42
39	TIP72	RING72	40
37	<BURN IN>	-	38
35	CC8KB	CC64KB	36
33	INTRPT12-	SCB12	34
31	RDATA12	RDATB12	32
29	CLKA12	CLKB12	30
27	RSIGA12	RSIGB12	28
25	FSYNCA12	FSYNCB12	26
23	TDATA12	TDATB12	24
21	TSIGA12	TSIGB12	22
19	TSTTIP	TSTRING	20
17	GND	GND	18
15	BATA_H	BATA_H	16
13	BATB_H	BATB_H	14
11	-	-	12
9	HTIPA12	HTIPB12	10
7	HRINGA12	HRINGB12	8
5	FGND	FGND	6
3	4WRXT12	4WRXR12	4
1	4WTXT12	4WTXR12	2

Table 14 COLU #13 (J16) Connector Pinouts

Pin #	Assignment	Assignment	Pin #
49	TIP73	RING73	50
47	TIP74	RING74	48
45	TIP75	RING75	46
43	TIP76	RING76	44
41	TIP77	RING77	42
39	TIP78	RING78	40
37	<BURN IN>	-	38
35	CC8KB	CC64KB	36
33	INTRPT13-	SCB13	34
31	RDATA13	RDATB13	32
29	CLKA13	CLKB13	30
27	RSIGA13	RSIGB13	28
25	FSYNCA13	FSYNCB13	26
23	TDATA13	TDATB13	24
21	TSIGA13	TSIGB13	22
19	TSTTIP	TSTRING	20
17	GND	GND	18
15	BATA_H	BATA_H	16
13	BATB_H	BATB_H	14
11	-	-	12
9	HTIPA13	HTIPB13	10
7	HRINGA13	HRINGB13	8
5	FGND	FGND	6
3	4WRXT13	4WRXR13	4
1	4WTXT13	4WTXR13	2

Table 15 COLU #14 (J17) Connector Pinouts

Pin #	Assignment	Assignment	Pin #
49	TIP79	RING79	50
47	TIP80	RING80	48
45	TIP81	RING81	46
43	TIP82	RING82	44
41	TIP83	RING83	42
39	TIP84	RING84	40
37	<BURN IN>	-	38
35	CC8KB	CC64KB	36
33	INTRPT14-	SCB14	34
31	RDATA14	RDATB14	32
29	CLKA14	CLKB14	30
27	RSIGA14	RSIGB14	28
25	FSYNCA14	FSYNCB14	26
23	TDATA14	TDATB14	24
21	TSIGA14	TSIGB14	22
19	TSTTIP	TSTRING	20
17	GND	GND	18
15	BATA_H	BATA_H	16
13	BATB_H	BATB_H	14
11	-	-	12
9	HTIPA14	HTIPB14	10
7	HRINGA14	HRINGB14	8
5	FGND	FGND	6
3	4WRXT14	4WRXR14	4
1	4WTXT14	4WTXR14	2

Table 16 COLU #15 (J18) Connector Pinouts

Pin #	Assignment	Assignment	Pin #
49	TIP85	RING85	50
47	TIP86	RING86	48
45	TIP87	RING87	46
43	TIP88	RING88	44
41	TIP89	RING89	42
39	TIP90	RING90	40
37	<BURN IN>	–	38
35	CC8KB	CC64KB	36
33	INTRPT15-	SCB15	34
31	RDATA15	RDATB15	32
29	CLKA15	CLKB15	30
27	RSIGA15	RSIGB15	28
25	FSYNCA15	FSYNCB15	26
23	TDATA15	TDATB15	24
21	TSIGA15	TSIGB15	22
19	TSTTIP	TSTRING	20
17	GND	GND	18
15	BATA_H	BATA_H	16
13	BATB_H	BATB_H	14
11	–	–	12
9	HTIPA15	HTIPB15	10
7	HRINGA15	HRINGB15	8
5	FGND	FGND	6
3	4WRXT15	4WRXR15	4
1	4WTXT15	4WTXR15	2

Table 17 COLU #16 (J19) Connector Pinouts

Pin #	Assignment	Assignment	Pin #
49	TIP91	RING91	50
47	TIP92	RING92	48
45	TIP93	RING93	46
43	TIP94	RING94	44
41	TIP95	RING95	42
39	TIP96	RING96	40
37	<BURN IN>	–	38
35	CC8KB	CC64KB	36
33	INTRPT16-	SCB16	34
31	RDATA16	RDATB16	32
29	CLKA16	CLKB16	30
27	RSIGA16	RSIGB16	28
25	FSYNCA16	FSYNCB16	26
23	TDATA16	TDATB16	24
21	TSIGA16	TSIGB16	22
19	TSTTIP	TSTRING	20
17	GND	GND	18
15	BATA_H	BATA_H	16
13	BATB_H	BATB_H	14
11	–	–	12
9	HTIPA16	HTIPB16	10
7	HRINGA16	HRINGB16	8
5	FGND	FGND	6
3	4WRXT16	4WRXR16	4
1	4WTXT16	4WTXR16	2

Alarm Cutoff

The shelf backplane provides a wire-wrap pin for connection to an external alarm cutoff circuit.

Alarm Contacts

The PG-Plus COTS provides access to the PG-Plus Alarm Unit (PAU) alarm relays by way of wire-wrap pins on the shelf backplane. Both normally open (NO) and normally closed (NC) relay operation is supported. Figure 5 shows the configuration of the alarm relays.

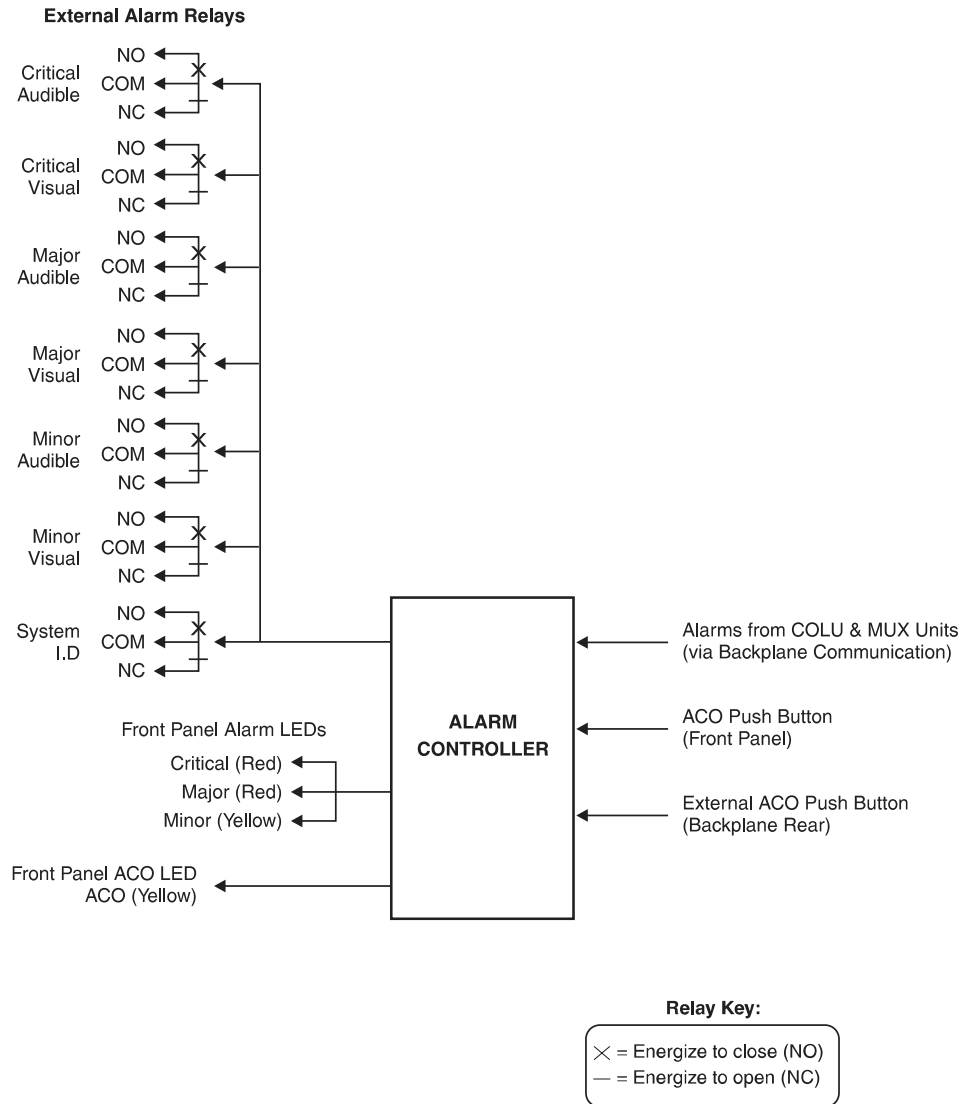

Figure 5 Alarm Relay Contacts from PAU to Wire-Wrap Field

OS Interface

The PG-Plus COTS supports RS-232 X.25 interfaces through a backplane-mounted DB25 connector.

LAN Interface

The PG-Plus COTS supports interconnecting multiple shelves by means of a 10base^T BNC LAN connector. This feature is used with a PG-Plus PMU unit.

DSX1 Connections

The COTS provides direct 100 Ω resistive termination for eight DS1 inputs from the DSX-1 cross-connect by way of wire-wrap pins located at the bottom right-hand side of the shelf backplane. The DS1 inputs are bridged to both PMX slots to allow for 1:1 equipment protection.

PAU/PMU Connector

J1 on the COTS backplane is the 96-pin DIN-type PAU/PMU connector. Table 18 lists the PAU/PMU connector pinouts.

Table 18 PAU/PMU 96-Pin DIN-Type Connector

Pin #	Row A	Row B	Row C
32	MJRAUDNO	MJRAUDCOM	MJRAUDNC
31	MJRVISNO	MJRVISCOM	MJRVISNC
30	MNRAUDNO	MNRAUDCOM	MNRAUDNC
29	MNRVISNO	MNRVISCOM	MNRVISNC
28	CRITAUDNO	CRITAUDCOM	CRITAUDNC
27	CRITVISNO	CRITVISCOM	CRITVISNC
26	SYSNO	SYSCOM	SYSNC
25	SCB1	INTRPT1-	CC1TIP
24	SCB2	INTRPT2-	CC1RING
23	SCB3	INTRPT3-	CC2TIP
22	SCB4	INTRPT4-	CC2RING
21	SCB5	INTRPT5-	ACO1
20	SCB6	INTRPT6-	GND
19	SCB7	INTRPT7-	TSTTIP
18	SCB8	INTRPT8-	TSTRING
17	SCB9	INTRPT9-	CC64KA
16	SCB10	INTRPT10-	CC8KA
15	SCB11	INTRPT11-	CC64KB
14	SCB12	INTRPT12-	CC8KB
13	SCB13	INTRPT13-	INTRPTA-
12	SCB14	INTRPT14-	FSYNCAEOC
11	SCB15	INTRPT15-	RCLKAEOC
10	SCB16	INTRPT16-	INTRPTB-
9	SCBA	SCBB	FSYNCBEOC
8	BATB_H	TDATBEOC	RCLKBEOC
7	RDATAEOC	RDATBEOC	
6	BATA_L	TDATAEOC	FGND
5	GND	ID1	ID0
4	NMATX	NMARX	<BURN IN>
3	NMADTR	NMADSR	NMAGND
2	NMACD	NMARCLK	NMATCLK
1	LAN	LGND	LGND

PMX Connector

J2 and J3 on the COTS backplane are the 160-pin DIN-type PMX connectors. Table 19 lists the PMX A (labeled as PMX 1 on the front of the shelf) connector pinouts. Table 20 lists the PMX B (labeled as PMX 2 on the front of the shelf) connector pinouts.

Table 19 PMX 1 160-Pin DIN-Type Connector

Pin #	Row A	Row B	Row C	Row D	Row E
32	RDATA1	RDATA2	RDATA3	RDATA4	RDATA5
31	RSIGA1	RSIGA2	RSIGA3	RSIGA4	RSIGA5
30	TDATA1	TDATA2	TDATA3	TDATA4	TDATA5
29	TSIGA1	TSIGA2	TSIGA3	TSIGA4	TSIGA5
28	CLKA1	CLKA2	CLKA3	CLKA4	CLKA5
27	FSYNCA1	FSYNCA2	FSYNCA3	FSYNCA4	FSYNCA5
26	GND	GND	GND	GND	GND
25	RDATA6	RDATA7	RDATA8	RDATA9	RDATA10
24	RSIGA6	RSIGA7	RSIGA8	RSIGA9	RSIGA10
23	TDATA6	TDATA7	TDATA8	TDATA9	TDATA10
22	TSIGA6	TSIGA7	TSIGA8	TSIGA9	TSIGA10
21	CLKA6	CLKA7	CLKA8	CLKA9	FSYNCA10
20	FSYNCA6	FSYNCA7	FSYNCA8	FSYNCA9	CLKA10
19	GND	GND	GND	GND	GND
18	RDATA11	RDATA12	RDATA13	RDATA14	RDATA15
17	RSIGA11	RSIGA12	RSIGA13	RSIGA14	RSIGA15
16	TDATA11	TDATA12	TDATA13	TDATA14	TDATA15
15	TSIGA11	TSIGA12	TSIGA13	TSIGA14	TSIGA15
14	CLKA11	CLKA12	CLKA13	CLKA14	CLKA15
13	FSYNCA11	FSYNCA12	FSYNCA13	FSYNCA14	FSYNCA15
12	RDATA16	RSIGA16	CLKA16	SCBA	RDATAEOC
11	BATA_L	TSIGA16	FSYNCA16	INTRPTA-	TDATAEOC
10	BATA_L	TDATA16	RCLKAEOC	FSYNCAEOC	BATB_H
9	B2A	GND	A2B	GND	BATB_H
8	-	-	-	-	<RESERVED>
7	RXTIP1	RXTIP4	TXTIP4	RXTIP7	FGND
6	RXRING1	RXRING4	TXRING4	RXRING7	FGND
5	TXTIP1	RXTIP3	RXTIP5	TXTIP7	-
4	TXRING1	RXRING3	RXRING5	TXRING7	RXTIP8
3	RXTIP2	TXTIP3	TXTIP5	RXTIP6	RXRING8
2	RXRING2	TXRING3	TXRING5	RXRING6	TXTIP8
1	TXTIP2	TXRING2	TXRING6	TXTIP6	TXRING8

Table 20 PMX 2 160-Pin DIN-Type Connector

Pin #	Row A	Row B	Row C	Row D	Row E
32	RDATB1	RDATB2	RDATB3	RDATB4	RDATB5
31	RSIGB1	RSIGB2	RSIGB3	RSIGB4	RSIGB5
30	TDATB1	TDATB2	TDATB3	TDATB4	TDATB5
29	TSIGB1	TSIGB2	TSIGB3	TSIGB4	TSIGB5
28	CLKB1	CLKB2	CLKB3	CLKB4	CLKB5
27	FSYNCB1	FSYNCB2	FSYNCB3	FSYNCB4	FSYNCB5
26	GND	GND	GND	GND	GND
25	RDATB6	RDATB7	RDATB8	RDATB9	RDATB10
24	RSIGB6	RSIGB7	RSIGB8	RSIGB9	RSIGB10
23	TDATB6	TDATB7	TDATB8	TDATB9	TDATB10
22	TSIGB6	TSIGB7	TSIGB8	TSIGB9	TSIGB10
21	CLKB6	CLKB7	CLKB8	CLKB9	FSYNCB10
20	FSYNCB6	FSYNCB7	FSYNCB8	FSYNCB9	CLKB10
19	GND	GND	GND	GND	GND
18	RDATB11	RDATB12	RDATB13	RDATB14	RDATB15
17	RSIGB11	RSIGB12	RSIGB13	RSIGB14	RSIGB15
16	TDATB11	TDATB12	TDATB13	TDATB14	TDATB15
15	TSIGB11	TSIGB12	TSIGB13	TSIGB14	TSIGB15
14	CLKB11	CLKB12	CLKB13	CLKB14	CLKB15
13	FSYNCB11	FSYNCB12	FSYNCB13	FSYNCB14	FSYNCB15
12	RDATB16	RSIGB16	CLKB16	SCBB	RDATBEOC
11	BATA_L	TSIGB16	FSYNCB16	INTRPTB-	TDATBEOC
10	BATA_L	TDATB16	RCLKBEOC	FSYNCBEOC	BATB_H
9	A2B	GND	B2A	GND	BATB_H
8	-	-	-	-	<RESERVED>
7	RXTIP1	RXTIP4	TXTIP4	RXTIP7	FGND
6	RXRING1	RXRING4	TXRING4	RXRING7	FGND
5	TXTIP1	RXTIP3	RXTIP5	TXTIP7	-
4	TXRING1	RXRING3	RXRING5	TXRING7	RXTIP8
3	RXTIP2	TXTIP3	TXTIP5	RXTIP6	RXRING8
2	RXRING2	TXRING3	TXRING5	RXRING6	TXTIP8
1	TXTIP2	TXRING2	TXRING6	TXTIP6	TXRING8

SPECIFICATIONS

Dimensions

Height	6.5 inches
Width	23 inches
Depth	12 inches with line cards installed
Weight	12.5 lbs.

Mounting

23-inch equipment rack using universal mounting brackets



Mounting the COTS in a 23-inch equipment rack on extended brackets is not recommended where vibration is a concern.

Environment

Temperature	-40°F to +149°F; -40°C to + 65°C
Humidity	5% to 95% (noncondensing)
Altitude	-200 ft. MSL to 13,000 ft. MSL; -60 m MSL to 4,000 m MSL
Vibration	NEBS

INSTALLATION AND TEST

REQUIRED TOOLS AND TEST EQUIPMENT

The tools and test equipment required for the installation of the COTS are:

- One wire-wrap tool for .045-inch square pins
- One #2 Phillips screwdriver
- One flat-head screwdriver
- One pair wire-strippers
- One pair side-cutters
- One Volt-Ohmmeter

POWER

The COTS uses –48 V dc CO battery. This voltage must be fused on a fuse panel in the CO. The fuse rating depends on the powering option used.

MOUNTING

Attach the COTS to the selected position in the 23-inch equipment frame.

WIRING ACCESS

All wiring to the COTS is done on the backplane. To access the backplane, remove the clear Plexiglas™ cover.

ALARM LEADS

Audible and visual alarm leads from the CO alarm panel to the COTS must be provided. Run the Alarm leads down the side of the COTS mounting frame.

HDSL LINES

One pair of leads from the COTS to the HDSL pair Tip and Ring at the distribution frame must be provided for each system in the COTS. These leads should be dressed along the side of the frame per local practices.

SUBSCRIBER LINES

Four 50-pin connector-ended (female) cables per system are required for connecting the COTS to the CO switch subscriber line circuits at the distribution frame. Dress the cables along the sides of the frame per local practices.

CONNECTIONS

Ground Connections



Frame Ground must be connected to provide discharge path for outside plant protection circuits.

Two Frame Ground termination points are provided on the COTS. The J22 and TB1 FGND Frame Ground termination points are electrically equivalent. To ground the COTS, perform one of the following options:

- **J22 Connection**

The preferred termination point is at J22, located on the lower left corner of the COTS backplane. This ground lug will accept wire in the range of 6 to 12 AWG.



Use this connection only if the equipment frame has a common equipment ground wire running along the vertical member of the frame.

- a Using a wire gauge of the same size as the common equipment frame ground wire, remove 5/8-inch of insulation and insert into the ground lug J22.
- b Using a flat-head screwdriver, secure the wire in the lug.
- c Attach the other end to the common equipment frame ground using locally approved methods.

- **TB1 FGND Connection**

The seven-position power-terminal strip termination point, TB1, is on the shelf backplane. A minimum of 12 AWG should be used for this connection.

- a Using minimum 12 AWG wire, attach a spade lug connector to terminate the ground wire on the FGND terminal of TB1.
- b Connect the other end of the frame ground wire to the CO Frame Ground termination point using locally approved methods.

Power Connections

The TB1 termination point on the COTS backplane provides connections for dual -48 V dc, common battery return, and frame ground to each of the card slots by way of screw terminals. The shelf can be wired for redundant powering, split-powering, or single-source powering depending upon requirements. The following sections describe the three powering options available on this device. The preferred powering method is redundant-shelf powering. Prior to performing any power connections:

- 1 Remove all fuses in the equipment bay's fuse panel for the circuit where the PG-Plus -48 V dc power leads will be terminated until the COTS is wired and ready for turn-up.
- 2 Run the battery and battery return lines from the fuse panel to the COTS mounting frame using a minimum of 12 AWG wire.
- 3 Connect to a reliably grounded -48 V dc source that is electrically isolated from the AC source.
- 4 The branch circuit overcurrent protection shall be rated 48 V, 20 A.
- 5 Disconnect both input supply sources before servicing.

Redundant-Shelf Powering

Each circuit card in the COTS receives power from two -48 V dc sources. If one -48 V dc source is lost, the other -48 V dc source provides power to the shelf circuit cards. Each -48 V dc source is fused at 20 amps.

A four-position jumper is in place on the TB1 block (Figure 6). This jumper shorts all of the 48 VDC inputs together to prevent an alarm situation when only one input feed wire is connected. To provide redundant-shelf powering:

- 1 Ensure that the ground connection is in place.
- 2 Remove the four-position jumper from TB1.
- 3 Cut the four-position jumper in half, then cut out a small strip to ensure a gap between the two pieces when they are replaced (see Figure 6).
- 4 Replace the two pieces on the TB1 block, connecting TB1-1 to TB1-2 with one piece; then TB-3 to TB-4 with the second piece.
- 5 Connect a wire to the -48A-LOW terminal of TB1. Connect the opposite end of this wire to the CO A battery supply terminal at the fuse panel (labeled -48A-HIGH).
- 6 Connect a wire to the -48B-HIGH terminal of TB1. Connect the opposite end of this wire to the CO B battery supply at the fuse panel (labeled -48B-HIGH).
- 7 Connect a wire from the Battery Return terminal in position 5 of TB1 on the COTS backplane to the A CO battery return at the fuse panel.
- 8 Connect a wire from the Battery Return terminal in position 6 of TB1 on the COTS backplane to the B CO battery return at the fuse panel.

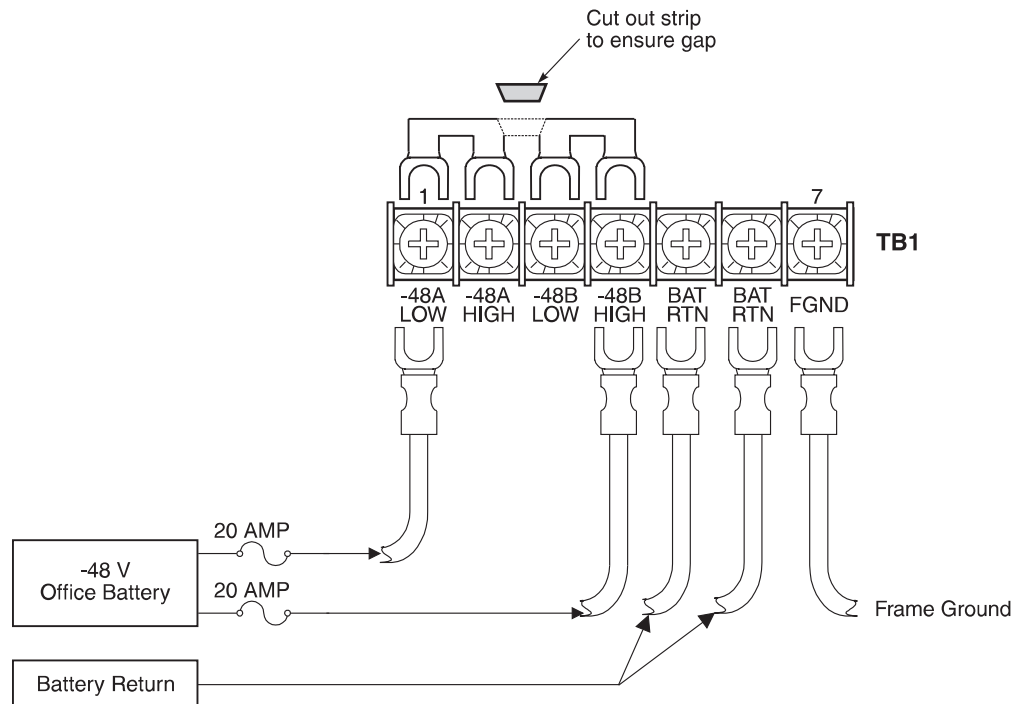

Figure 6 Redundant Shelf Power Wiring

Split-Shelf Powering

One half of the shelf is powered from one -48 V dc source, the other half is powered from another -48 V dc source. Common equipment circuit cards are powered from both sources. If one power supply should fail, one-half of the shelf maintains power. Each -48 V dc source is fused at 10 amps.

A four-position jumper is in place on the TB1 block (refer to Figure 6). This jumper shorts all of the 48 VDC inputs together to prevent an alarm situation when only one input feed wire is connected. To provide split-shelf powering:

- 1 Ensure that the ground connection is in place.
- 2 Remove the four-position jumper (refer to Figure 6) and discard.
- 3 Connect a wire to the -48A-LOW terminal of TB1 (see Figure 7). Connect the opposite end of this wire to the A CO battery supply at the fuse panel.
- 4 Connect a wire to the -48B-HIGH terminal of TB1. Connect the opposite end of this wire to the B CO battery supply at the fuse panel.
- 5 Connect a wire from the Battery Return terminal in position 5 of TB1 on the COTS backplane to the A CO battery return at the fuse panel.
- 6 Connect a wire from the Battery Return terminal in position 6 of TB1 on the COTS backplane to the B CO battery return at the fuse panel.
- 7 Use a short jumper wire to connect the -48 A-LOW and -48 B-LOW terminals of TB1. Make this connection at the top of the terminal block as shown in Figure 7.
- 8 Connect a wire from the -48A-HIGH to the -48B-HIGH terminals of TB1. Make this connection at the top of the terminal block as shown in Figure 7.

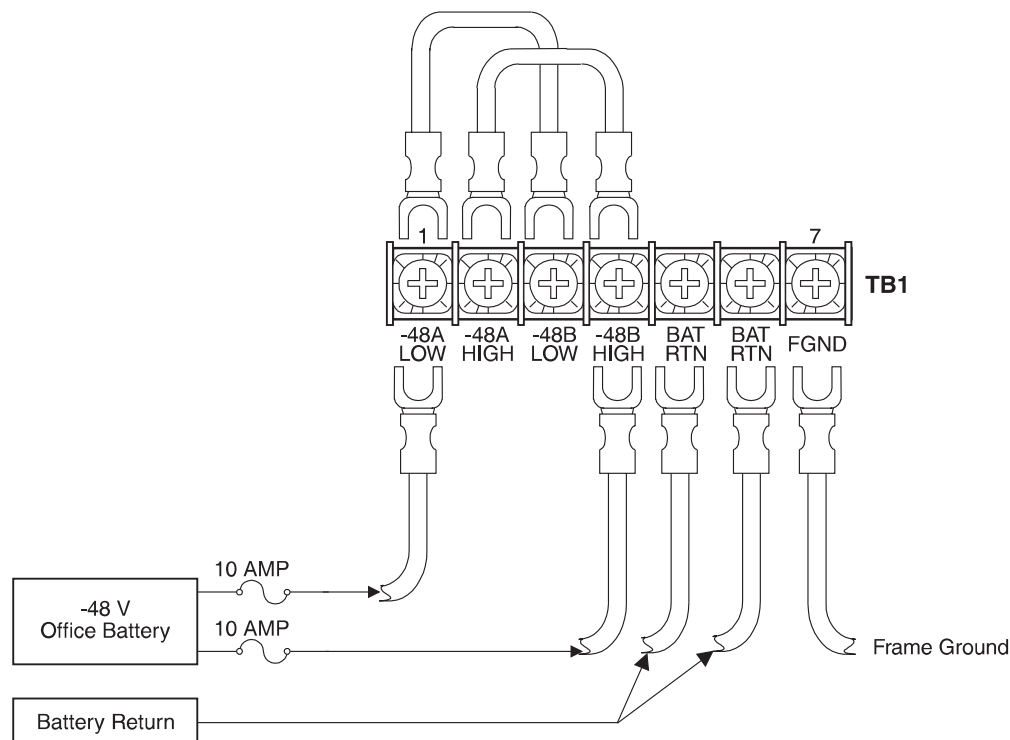

Figure 7 Split-Shelf Wiring

Single-Source Powering

The entire shelf is powered from a single source of -48 V dc power fused at 20 amps.

A four-position jumper is in place on the TB1 block. This jumper shorts all of the 48 VDC inputs together to prevent an alarm situation when only one input feed wire is connected. To provide single-source powering:

- 1 Ensure that the ground connection is in place.
- 2 Connect a wire to the -48A-LOW terminal at TB1 (Figure 8). Connect the opposite end of this wire to the -48 V dc CO battery supply at the fuse panel.
- 3 Connect a wire to the Battery Return terminal in position 6 of TB1. Connect the opposite end of this wire to the battery return of the CO battery supply at the fuse panel.
- 4 Connect a jumper wire from the -48A-LOW terminal of TB1 to the -48B-HIGH terminal of TB1.

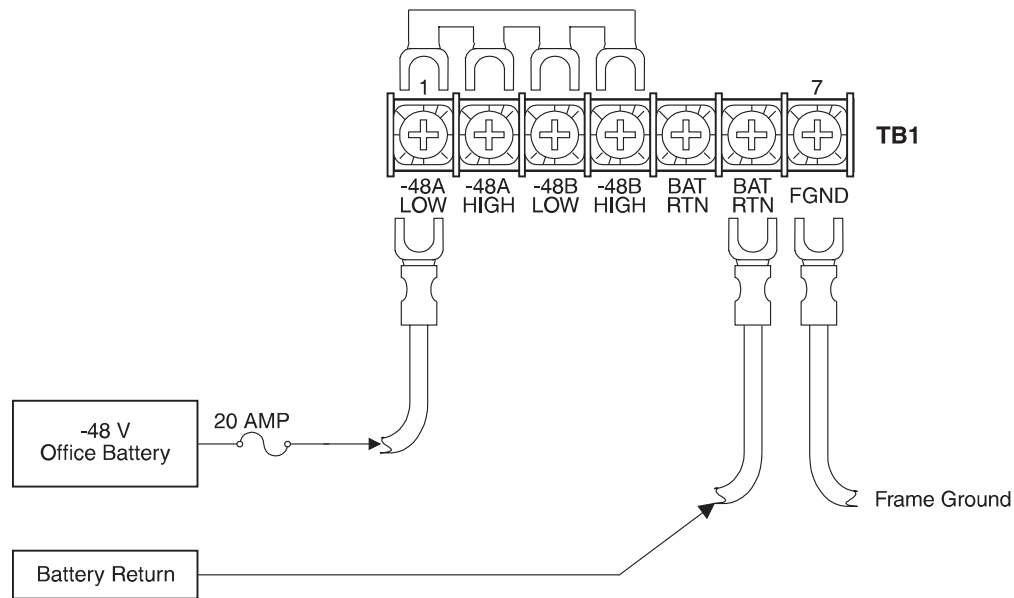

Figure 8 Single-Source Power Wiring



If the -48HIGH and the -48LOW terminals are not jumpered, the COLU power LED will blink, because one of the power rails is missing.

Audible and Visual Alarm Connections

Use a wire-wrap tool to terminate the alarm leads from the external alarm equipment on the alarm relay wire-wrap field. See Figure 9 for the location of the alarm relay wire-wrap field. Table 21 shows the layout of the wire-wrap pins on the COTS backplane.

If a remote ACO switch is to be wired, refer to the *External ACO Connection* section for wire-wrap pin field location.

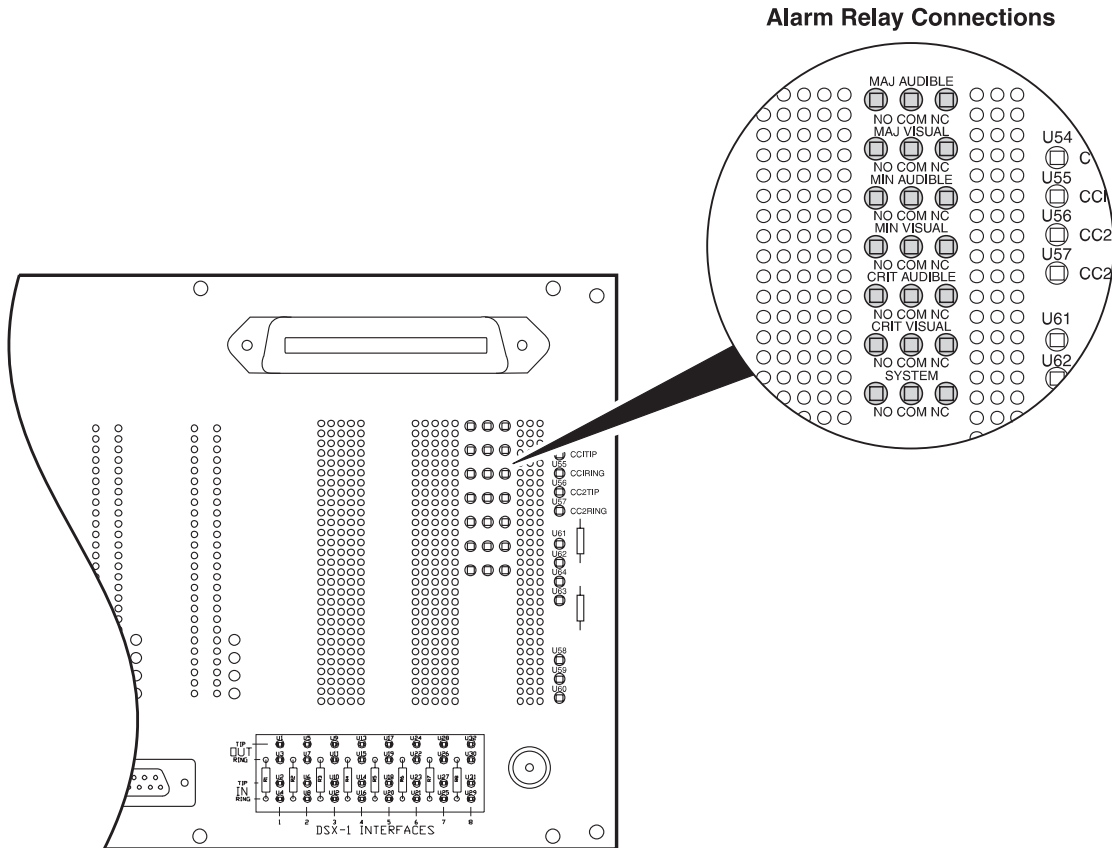

Figure 9 Alarm Relay Wire-Wrap Field

Table 21 Alarm Relay Wire-Wrap Field

Normally Open	Common Connection	Normally Closed Connection	Description
MJRAUDNO	MJRAUDCOM	MJRAUDNC	Major audio alarm
MJRVISNO	MJRVISCOM	MJRVISNC	Major visual alarm
MNRAUDNO	MNRAUDCOM	MNRAUDNC	Minor audio alarm
MNRVISNO	MNRVISCOM	MNRVISNC	Minor visual alarm
CRITAUDNO	CRITAUDCOM	CRITAUDNC	Critical audio alarm
CRITVISNO	CRITVISCOM	CRITVISNC	Critical visual alarm
SYSNO	SYSCOM	SYSNC	System Alarm (or all visual alarms)

Subscriber Connections From CO

Subscriber lines from the CO are connected to the COTS by way of 50-pin Telco connectors (P1, P2, P3, P4, and P5). Tables 22 through 25 show how the subscriber services are assigned at the Telco connectors. Tables 26 through 30 list the Telco connector pinouts.

Table 22 P1 Tip and Ring Pin Assignments

Shelf Cardslot	COLU Type					Shelf Connector Assignments	
	PLL-720	PLL-721	PLL-722	PLL-723	PLL-724	Tip	Ring
LU1	POTS1	POTS1	POTS1		POTS	P1-26	P1-1
	POTS2	POTS2	POTS2			P1-27	P1-2
	POTS3	POTS3	POTS3			P1-28	P1-3
	POTS4	POTS4	ISDN	ISDN1	ISDN	P1-29	P1-4
		POTS5		ISDN2		P1-30	P1-5
		POTS6				P1-31	P1-6
LU2	POTS1	POTS1	POTS1		POTS	P1-32	P1-7
	POTS2	POTS2	POTS2			P1-33	P1-8
	POTS3	POTS3	POTS3			P1-34	P1-9
	POTS4	POTS4	ISDN	ISDN1	ISDN	P1-35	P1-10
		POTS5		ISDN2		P1-36	P1-11
		POTS6				P1-37	P1-12
LU3	POTS1	POTS1	POTS1		POTS	P1-38	P1-13
	POTS2	POTS2	POTS2			P1-39	P1-14
	POTS3	POTS3	POTS3			P1-40	P1-15
	POTS4	POTS4	ISDN	ISDN1	ISDN	P1-41	P1-16
		POTS5		ISDN2		P1-42	P1-17
		POTS6				P1-43	P1-18
LU4	POTS1	POTS1	POTS1		POTS	P1-44	P1-19
	POTS2	POTS2	POTS2			P1-45	P1-20
	POTS3	POTS3	POTS3			P1-46	P1-21
	POTS4	POTS4	ISDN	ISDN1	ISDN	P1-47	P1-22
		POTS5		ISDN2		P1-48	P1-23
		POTS6				P1-49	P1-24

Table 23 P2 Tip and Ring Pin Assignments

Shelf Cardslot	COLU Type					Shelf Connector Assignments	
	PLL-720	PLL-721	PLL-722	PLL-723	PLL-724	Tip	Ring
LU5	POTS1	POTS1	POTS1		POTS	P2-26	P2-1
	POTS2	POTS2	POTS2			P2-27	P2-2
	POTS3	POTS3	POTS3			P2-28	P2-3
	POTS4	POTS4	ISDN	ISDN1	ISDN	P2-29	P2-4
		POTS5		ISDN2		P2-30	P2-5
		POTS6				P2-31	P2-6
LU6	POTS1	POTS1	POTS1		POTS	P2-32	P2-7
	POTS2	POTS2	POTS2			P2-33	P2-8
	POTS3	POTS3	POTS3			P2-34	P2-9
	POTS4	POTS4	ISDN	ISDN1	ISDN	P2-35	P2-10
		POTS5		ISDN2		P2-36	P2-11
		POTS6				P2-37	P2-12
LU7	POTS1	POTS1	POTS1		POTS	P2-38	P2-13
	POTS2	POTS2	POTS2			P2-39	P2-14
	POTS3	POTS3	POTS3			P2-40	P2-15
	POTS4	POTS4	ISDN	ISDN1	ISDN	P2-41	P2-16
		POTS5		ISDN2		P2-42	P2-17
		POTS6				P2-43	P2-18
LU8	POTS1	POTS1	POTS1		POTS	P2-44	P2-19
	POTS2	POTS2	POTS2			P2-45	P2-20
	POTS3	POTS3	POTS3			P2-46	P2-21
	POTS4	POTS4	ISDN	ISDN1	ISDN	P2-47	P2-22
		POTS5		ISDN2		P2-48	P2-23
		POTS6				P2-49	P2-24

Table 24 P3 Tip and Ring Pin Assignments

Shelf Cardslot	COLU Type					Shelf Connector Assignments	
	PLL-720	PLL-721	PLL-722	PLL-723	PLL-724	Tip	Ring
LU9	POTS1	POTS1	POTS1		POTS	P3-26	P3-1
	POTS2	POTS2	POTS2			P3-27	P3-2
	POTS3	POTS3	POTS3			P3-28	P3-3
	POTS4	POTS4	ISDN	ISDN1	ISDN	P3-29	P3-4
		POTS5		ISDN2		P3-30	P3-5
		POTS6				P3-31	P3-6
LU10	POTS1	POTS1	POTS1		POTS	P3-32	P3-7
	POTS2	POTS2	POTS2			P3-33	P3-8
	POTS3	POTS3	POTS3			P3-34	P3-9
	POTS4	POTS4	ISDN	ISDN1	ISDN	P3-35	P3-10
		POTS5		ISDN2		P3-36	P3-11
		POTS6				P3-37	P3-12
LU11	POTS1	POTS1	POTS1		POTS	P3-38	P3-13
	POTS2	POTS2	POTS2			P3-39	P3-14
	POTS3	POTS3	POTS3			P3-40	P3-15
	POTS4	POTS4	ISDN	ISDN1	ISDN	P3-41	P3-16
		POTS5		ISDN2		P3-42	P3-17
		POTS6				P3-43	P3-18
LU12	POTS1	POTS1	POTS1		POTS	P3-44	P3-19
	POTS2	POTS2	POTS2			P3-45	P3-20
	POTS3	POTS3	POTS3			P3-46	P3-21
	POTS4	POTS4	ISDN	ISDN1	ISDN	P3-47	P3-22
		POTS5		ISDN2		P3-48	P3-23
		POTS6				P3-49	P3-24

Table 25 P4 Tip and Ring Pin Assignments

Shelf Cardslot	COLU Type					Shelf Connector Assignments	
	PLL-720	PLL-721	PLL-722	PLL-723	PLL-724	Tip	Ring
LU13	POTS1	POTS1	POTS1		POTS	P4-26	P4-1
	POTS2	POTS2	POTS2			P4-27	P4-2
	POTS3	POTS3	POTS3			P4-28	P4-3
	POTS4	POTS4	ISDN	ISDN1	ISDN	P4-29	P4-4
		POTS5		ISDN2		P4-30	P4-5
		POTS6				P4-31	P4-6
LU14	POTS1	POTS1	POTS1		POTS	P4-32	P4-7
	POTS2	POTS2	POTS2			P4-33	P4-8
	POTS3	POTS3	POTS3			P4-34	P4-9
	POTS4	POTS4	ISDN	ISDN1	ISDN	P4-35	P4-10
		POTS5		ISDN2		P4-36	P4-11
		POTS6				P4-37	P4-12
LU15	POTS1	POTS1	POTS1		POTS	P4-38	P4-13
	POTS2	POTS2	POTS2			P4-39	P4-14
	POTS3	POTS3	POTS3			P4-40	P4-15
	POTS4	POTS4	ISDN	ISDN1	ISDN	P4-41	P4-16
		POTS5		ISDN2		P4-42	P4-17
		POTS6				P4-43	P4-18
LU16	POTS1	POTS1	POTS1		POTS	P4-44	P4-19
	POTS2	POTS2	POTS2			P4-45	P4-20
	POTS3	POTS3	POTS3			P4-46	P4-21
	POTS4	POTS4	ISDN	ISDN1	ISDN	P4-47	P4-22
		POTS5		ISDN2		P4-48	P4-23
		POTS6				P4-49	P4-24

Table 26 P1 Telco Connector

Pin #	Assignment	Assignment	Pin #
1	RING1	TIP1	26
2	RING2	TIP2	27
3	RING3	TIP3	28
4	RING4	TIP4	29
5	RING5	TIP5	30
6	RING6	TIP6	31
7	RING7	TIP7	32
8	RING8	TIP8	33
9	RING9	TIP9	34
10	RING10	TIP10	35
11	RING11	TIP11	36
12	RING12	TIP12	37
13	RING13	TIP13	38
14	RING14	TIP14	39
15	RING15	TIP15	40
16	RING16	TIP16	41
17	RING17	TIP17	42
18	RING18	TIP18	43
19	RING19	TIP19	44
20	RING20	TIP20	45
21	RING21	TIP21	46
22	RING22	TIP22	47
23	RING23	TIP23	48
24	RING24	TIP24	49
25	FGND	FGND	50

Table 27 P2 Telco Connector

Pin #	Assignment	Assignment	Pin #
1	RING25	TIP25	26
2	RING26	TIP26	27
3	RING27	TIP27	28
4	RING28	TIP28	29
5	RING29	TIP29	30
6	RING30	TIP30	31
7	RING31	TIP31	32
8	RING32	TIP32	33
9	RING33	TIP33	34
10	RING34	TIP34	35
11	RING35	TIP35	36
12	RING36	TIP36	37
13	RING37	TIP37	38
14	RING38	TIP38	39
15	RING39	TIP39	40
16	RING40	TIP40	41
17	RING41	TIP41	42
18	RING42	TIP42	43
19	RING43	TIP43	44
20	RING44	TIP44	45
21	RING45	TIP45	46
22	RING46	TIP46	47
23	RING47	TIP47	48
24	RING48	TIP48	49
25	FGND	FGND	50

Table 28 P3 Telco Connector

Pin #	Assignment	Assignment	Pin #
1	RING49	TIP49	26
2	RING50	TIP50	27
3	RING51	TIP51	28
4	RING52	TIP52	29
5	RING53	TIP53	30
6	RING54	TIP54	31
7	RING55	TIP55	32
8	RING56	TIP56	33
9	RING57	TIP57	34
10	RING58	TIP58	35
11	RING59	TIP59	36
12	RING60	TIP60	37
13	RING61	TIP61	38
14	RING62	TIP62	39
15	RING63	TIP63	40
16	RING64	TIP64	41
17	RING65	TIP65	42
18	RING66	TIP66	43
19	RING67	TIP67	44
20	RING68	TIP68	45
21	RING69	TIP69	46
22	RING70	TIP70	47
23	RING71	TIP71	48
24	RING72	TIP72	49
25	FGND	FGND	50

Table 29 P4 Telco Connector

Pin #	Assignment	Assignment	Pin #
1	RING73	TIP73	26
2	RING74	TIP74	27
3	RING75	TIP75	28
4	RING76	TIP76	29
5	RING77	TIP77	30
6	RING78	TIP78	31
7	RING79	TIP79	32
8	RING80	TIP80	33
9	RING81	TIP81	34
10	RING82	TIP82	35
11	RING83	TIP83	36
12	RING84	TIP84	37
13	RING85	TIP85	38
14	RING86	TIP86	39
15	RING87	TIP87	40
16	RING88	TIP88	41
17	RING89	TIP89	42
18	RING90	TIP90	43
19	RING91	TIP91	44
20	RING92	TIP92	45
21	RING93	TIP93	46
22	RING94	TIP94	47
23	RING95	TIP95	48
24	RING96	TIP96	49
25	FGND	FGND	50

Table 30 P5 Telco Connector

Pin #	Assignment	Assignment	Pin #
1	4WTXR1	4WTXT1	33
2	4WRXR1	4WRXT1	34
3	4WTXR2	4WTXT2	35
4	4WRXR2	4WRXT2	36
5	4WTXR3	4WTXT3	37
6	4WRXR3	4WRXT3	38
7	4WTXR4	4WTXT4	39
8	4WRXR4	4WRXT4	40
9	4WTXR5	4WTXT5	41
10	4WRXR5	4WRXT5	42
11	4WTXR6	4WTXT6	43
12	4WRXR6	4WRXT6	44
13	4WTXR7	4WTXT7	45
14	4WRXR7	4WRXT7	46
15	4WTXR8	4WTXT8	47
16	4WRXR8	4WRXT8	48
17	4WTXR9	4WTXT9	49
18	4WRXR9	4WRXT9	50
19	4WTXR10	4WTXT10	51
20	4WRXR10	4WRXT10	52
21	4WTXR11	4WTXT11	53
22	4WRXR11	4WRXT11	54
23	4WTXR12	4WTXT12	55
24	4WRXR12	4WRXT12	56
25	4WTXR13	4WTXT13	57
26	4WRXR13	4WRXT13	58
27	4WTXR14	4WTXT14	59
28	4WRXR14	4WRXT14	60
29	4WTXR15	4WTXT15	61
30	4WRXR15	4WRXT15	62
31	4WTXR16	4WTXT16	63
32	4WRXR16	4WRXT16	64

Composite Clock Connections



This step is required only if provisioning for DDS circuits.

Termination resistors (TERM1 and TERM2) are located below the composite clock wire-wrap pins to provide the correct termination on the composite clock pins. To terminate the clock leads from the Telco Timing Source Generator to the COTS backplane:

- 1 Connect CC1TIP to one terminal of TERM 1, and CC1RING to the other terminal on TERM 1 (Figure 10).
- 2 Connect CC2TIP to one terminal of TERM 2, and CC2RING to the other terminal on TERM 2 if a second composite clock source is to be used.

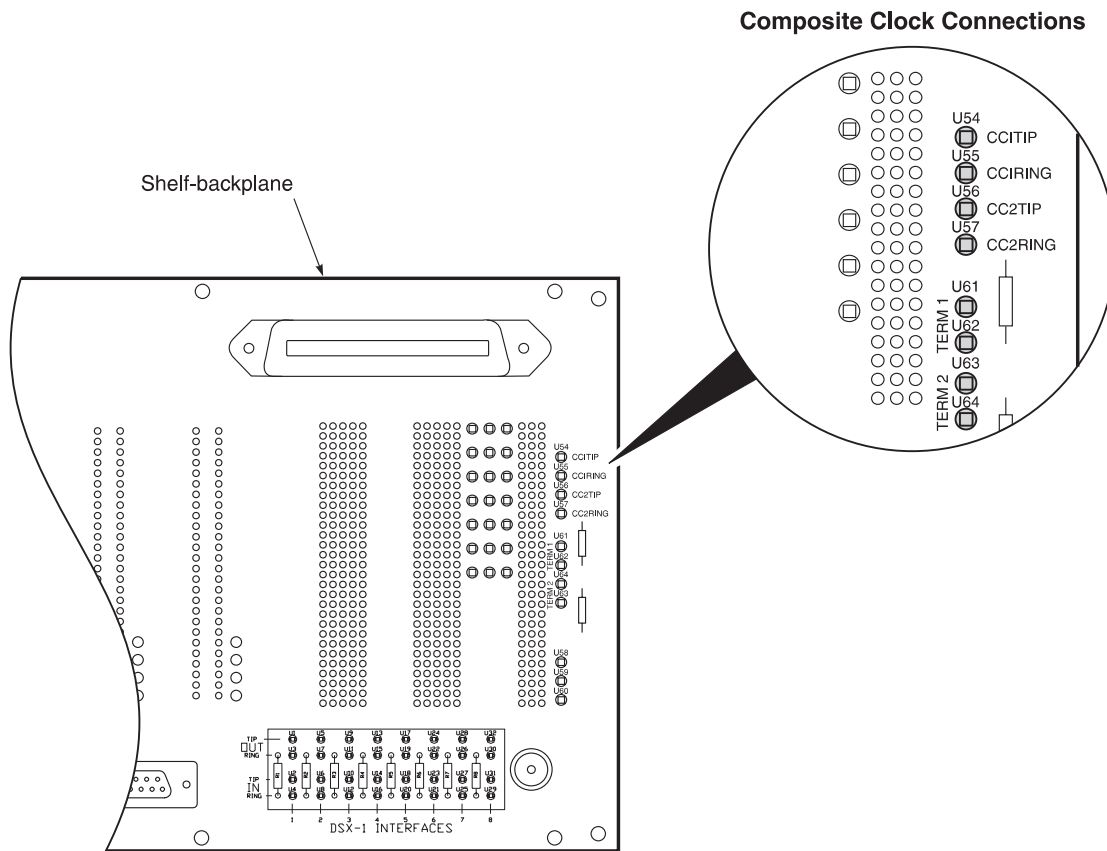

Figure 10 Composite Clock Wire Wrap Assignment

HDSL Wiring

J4 - J19 on the COTS backplane correspond to COLU slot numbers LU1 to LU16, and provide wiring support for two HDSL interfaces per COLU.

Figure 11 shows HDSL connections J4 and J5. The wire-wrap pin labels for J4 - J19 correspond to the COLU slot number. In Figure 11, DSL_A-1 is for the primary HDSL connection to COLU slot 1 (LU1). For COLU slot 16 (LU16), the wire-wrap pin label would read DSL_A-16. To make the wire-wrap terminations on the HDSL wire-wrap field:

- 1 Use a wire-wrap tool to terminate HDSL pair #1 onto the Tip and Ring wire-wrap pins labeled DSL_A-1.
- 2 Terminate the remainder of the required HDSL pairs onto the Tip and Ring wire-wrap pins on terminals DSL_A-2 (LU2) through DSL_A-16 (LU16).

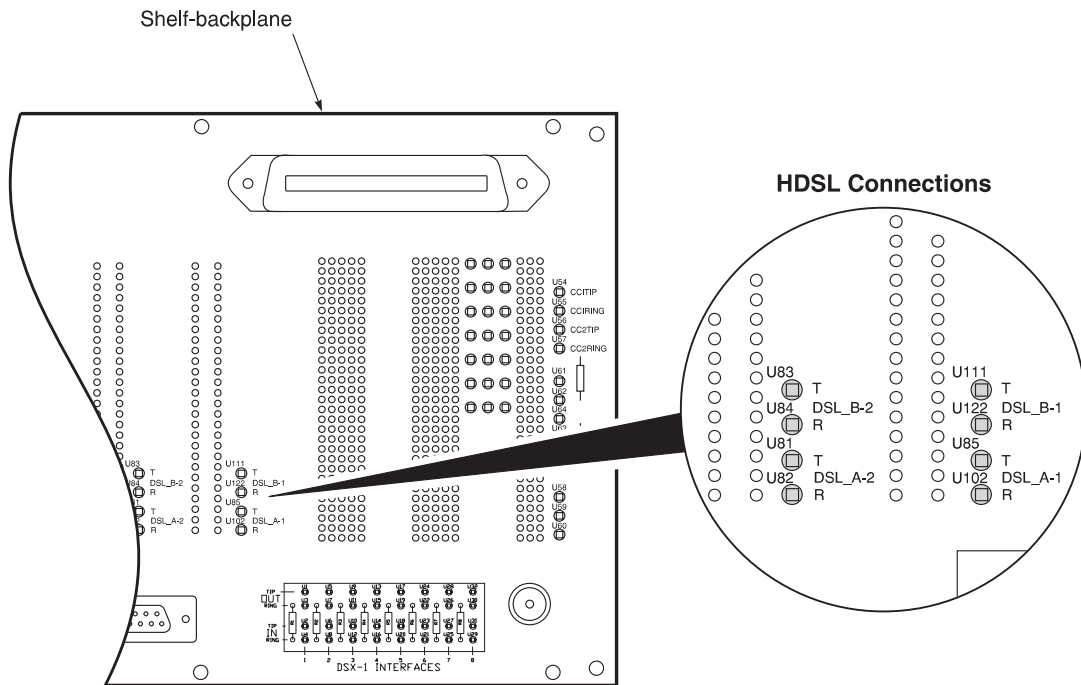

Figure 11 HDSL Wire-Wrap Pairs

External ACO Connection

The ACO connection is made on the pin labeled EXT ACO as shown in Figure 12. To control the ACO remotely, connect the ACO to GROUND through a Normally Open, momentary contact switch.

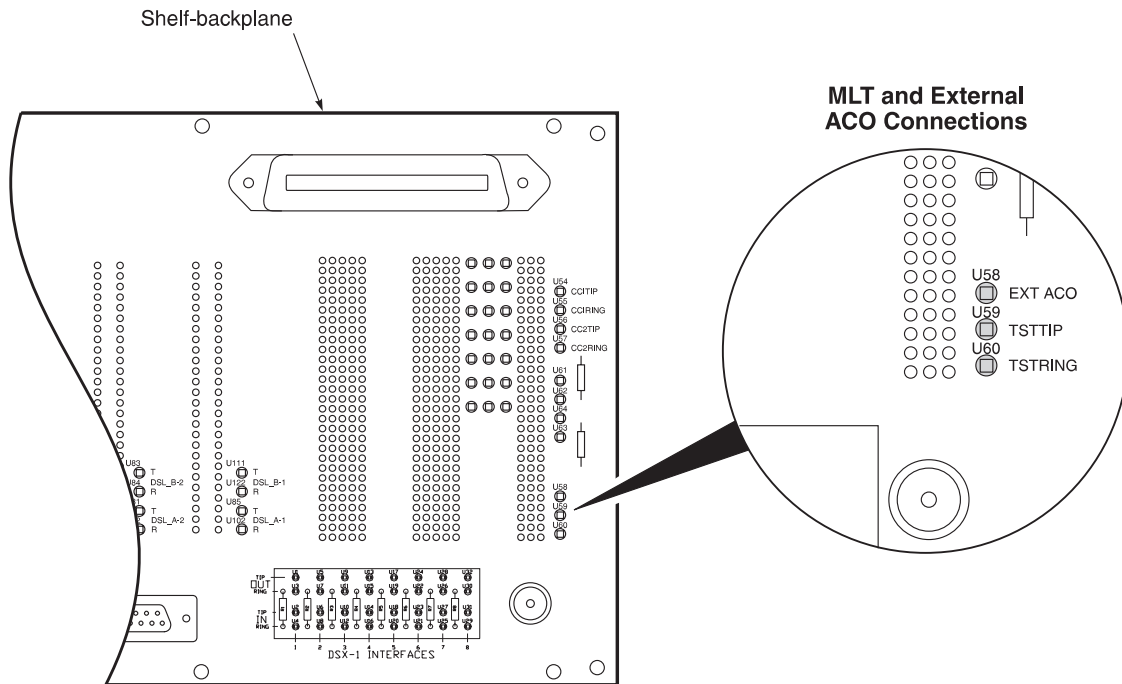

Figure 12 External ACO Wire-Wrap Connections

TURN-UP AND TEST



The following steps should be performed before any circuit cards are installed in the COTS.

- 1 Verify correct termination of all the HDSL lines on the wire-wrap field on the shelf backplane.
- 2 Install the fuses in the CO fuse panel for the circuits providing -48 V dc power to the COTS. Observe that the fuses hold when installed.
- 3 Verify that there is between -42 V dc and -56 V dc between each of the -48 V dc terminals and GND on TB1 on the COTS backplane.
- 4 Measure the dc voltage across the HDSL terminations. Ensure that there are 0 V dc between the Tip and Ring, Tip and Ground, and Ring and Ground of each HDSL circuit terminated on the shelf.
- 5 Measure the resistance across the terminals of the HDSL pairs. There should be at least 100 kΩ of resistance across the Tip and Ring, Tip and Ground, and Ring and Ground of each HDSL circuit terminated on the COTS backplane.
- 6 Replace the clear Plexiglas cover on the back of the COTS.

PRODUCT SUPPORT

TECHNICAL SUPPORT

PairGain Technical Assistance is available 24-hours-a-day, 7-days-a-week by contacting PairGain Customer Service Engineering group at:

Telephone: (800) 638-0031 or (714) 832-9922

Fax: (714) 832-9924

During normal business hours (8:00 AM to 5:00 PM, Pacific Time, Monday - Friday, excluding holidays), technical assistance calls are normally answered directly by a Customer Service Engineer. At other times, a request for technical assistance is handled by an on-duty Customer Service Engineer through a callback process. This process normally results in a callback within 30 minutes of initiating the request.

In addition, PairGain maintains a computer bulletin board system for obtaining current information on PairGain products, product troubleshooting tips and aids, accessing helpful utilities, and for posting requests or questions. This system is available 24-hours-a-day by calling (714) 730-3299. Transmission speeds up to 28.8 kbps are supported with a character format of 8-N-1.

WARRANTY

PairGain Technologies warrants this product to be free of defects and to be fully functional for a period of 60 months from the date of original shipment, given correct customer installation and regular maintenance. PairGain will repair or replace any unit without cost during this period if the unit is found to be defective for any reason other than abuse or incorrect use or installation.

Do not try to repair the unit. If it fails, replace it with another unit and return the faulty unit to PairGain for repair. Any modifications of the unit by anyone other than an authorized PairGain representative voids the warranty.

If a unit needs repair, call PairGain for a Return Material Authorization (RMA) number and return the defective unit, freight prepaid, along with a brief description of the problem, to:

PairGain Technologies, Inc.
14402 Franklin Avenue
Tustin, CA 92780
ATTN: Repair and Return Dept.
(800) 638-0031

PairGain continues to repair faulty modules beyond the warranty program at a nominal charge. Contact your PairGain sales representative for details and pricing.

FCC COMPLIANCE

This unit complies with the limits for Class A digital devices pursuant to Part 15 of the FCC rules. These limits are designed to provide reasonable protection against harmful interference when the equipment is operated in a commercial environment. This equipment generates, uses, and can radiate radio frequency energy and, if not installed and used in accordance with the instruction manual, can cause harmful interference to radio communications. Operation of this equipment in a residential area is likely to cause harmful interference, in which case the user will be required to correct the interference at his own expense.

Refer to the installation section of the appropriate instruction manual for the unit you are installing to get information on:

- Cabling
- Correct connections
- Grounding

MODIFICATIONS

The FCC requires the user to be notified that any changes or modifications made to this device that are not expressly approved by PairGain Technologies, Inc. may void the user's authority to operate the equipment.

All wiring external to the products should follow the provisions of the current edition of the National Electrical Code.

ABBREVIATIONS

ACO	<i>Alarm Cut-Off.</i> A switch used to silence audible alarms.
AWG	<i>American Wire Gauge</i>
CO	<i>Central Office</i>
COLU	<i>Central Office Line Unit.</i> PG-Plus HDSL Interface Unit.
COTS	<i>Central Office Terminal Shelf.</i> PG-Plus Central Office Shelf including line units and common equipment.
DDS	<i>Digital Data Service</i>
DS1	<i>Digital Signal One.</i> A 1.544 Mbps carrier signal.
ESD	<i>Electrostatic Discharge</i>
HDSL	<i>High-bit-rate Digital Subscriber Line</i>
LED	<i>Light-Emitting Diode</i>
MLT	<i>Mechanized Loop Testing.</i> Per TA297.
PAU	<i>PG-Plus Alarm Unit</i>
PMU	<i>PG-Plus Management Unit</i>
POTS	<i>Plain Old Telephone Service</i>
PRL	<i>PG-Plus Remote Line unit</i>
PMX	<i>PG-Plus Multiplexer Unit.</i>
RLU	<i>Remote Line Unit (circuitry only)</i>
RMA	<i>Return Materials Authorization</i>
RT	<i>Remote Terminal (enclosure and RLU inclusive)</i>
SDT	<i>Subscriber Drop Test</i>

Corporate Office
14402 Franklin Avenue
Tustin, CA 92780

Tel: (714) 832-9922
Fax: (714) 832-9924

For Technical Assistance:
(800) 638-0031

