

# PG-FLEX

## TECHNICAL PRACTICE



### CENTRAL OFFICE TERMINAL LINE UNIT

Model	List	CLEI Code
FLL-716	3C	N/A

---

**Revision History of This Practice**

<b>Revision</b>	<b>Release Date</b>	<b>Revisions Made</b>
01	February 3, 1999	Initial release
02	May 2, 2002	Release to rebrand document to comply with ADC standards
03	January 6, 2003	Updated Product Support Information

**©Copyright 2003 ADC DSL Systems, Inc. All Rights Reserved.**

*ADC is a registered trademark of ADC Technologies, Inc. PG-Flex is a registered trademark of ADC DSL Systems, Inc. No right, license, or interest to such trademarks is granted hereunder, and you agree that you shall assert no such right, license, or interest with respect to such trademarks. Other product names mentioned in this document are used for identification purposes only and may be trademarks or registered trademarks of their respective companies.*

*Information contained in this document is company private to ADC DSL Systems, Inc., and shall not be modified, used, copied, reproduced or disclosed in whole or in part without the written consent of ADC.*

*Contents herein are current as of the date of publication. ADC reserves the right to change specifications at any time without notice. Information furnished by ADC is believed to be accurate and reliable. In no event shall ADC be liable for any damages resulting from the loss of data, loss of use, or loss of profits and ADC further disclaims any and all liability for indirect, incidental, special, consequential or other similar damages. This disclaimer of liability applies to all products, publications and services during and after the warranty period.*

## USING THIS PRACTICE

Three types of messages, identified by icons, appear in the text.



**Notes indicate information about special circumstances.**



**Cautions indicate the possibility of equipment damage or the possibility of personal injury.**



**Electrostatic Discharge (ESD) susceptibility symbols indicate that a device or assembly is susceptible to damage from electrostatic discharge. You must wear an antistatic wrist strap connected to the appropriate ground connection prior to performing installation procedures. You must also observe normal ESD precautions when handling electronic equipment. Do not hold electronic plugs by their edges. Do not touch components or circuitry.**

## INSPECTING YOUR SHIPMENT

Upon receipt of the equipment:

- Unpack each container and visually inspect the contents for signs of damage. If the equipment has been damaged in transit, immediately report the extent of damage to the transportation company and to ADC. Order replacement equipment, if necessary.
- Check the packing list to ensure complete and accurate shipment of each listed item. If the shipment is short or irregular, contact ADC as described in [“Returns” on page 37](#). If you must store the equipment for a prolonged period, store the equipment in its original container.



---

## TABLE OF CONTENTS

<b>Product Overview</b> .....	<b>1</b>
Description and Features .....	1
Front Panel .....	2
<b>Specifications</b> .....	<b>4</b>
<b>Functional Description</b> .....	<b>5</b>
Overview .....	5
HDSL Transmission .....	6
Subscriber Drop Testing .....	6
Operational Capabilities .....	7
<b>Installation and Configuration</b> .....	<b>8</b>
Unpacking .....	8
Installation .....	8
Terminal Management .....	9
Connecting the FLL-716 to an ASCII Terminal or Modem .....	9
Connecting the ASCII Terminal to the FAU Card .....	12
Connection through the FAU card .....	12
Connection through the FLL-716 Line Unit .....	14
System Time Screen .....	15
Configuration, Maintenance, and Testing .....	16
Menus and Display Structure .....	16
Main Menu .....	17
Configure System Settings .....	19
Configure an ISDN Channel Unit .....	22
Channel Configuration .....	24
Display Time Slot Assignments .....	25
Configure Loop Start/Ground Start Channel Units .....	26
Display Doubler Status .....	27
Display Alarm History .....	28
Display ISDN Performance Monitoring .....	29
Maintenance .....	31
Metallic Access .....	32
ISDN Loopback Menu .....	34
Display System Inventory .....	35
<b>Troubleshooting</b> .....	<b>36</b>
<b>Product Support</b> .....	<b>37</b>
Technical Support .....	37

Limited Warranty .....	37
Returns.....	37
FCC Class A Compliance.....	39
Modifications.....	39
<b>Acronyms</b> .....	<b>40</b>
<b>Glossary</b> .....	<b>40</b>

## LIST OF FIGURES

1. FLL-716 Front Panel .....	2
2. Typical PG-Flex Configuration .....	5
3. FLL-716 Block Diagram .....	7
4. PG-Flex to Terminal (DB-9) .....	10
5. PG-Flex to Terminal (DB-25) .....	11
6. PG-Flex to Modem (DB-25) .....	11
7. Terminal Menu and Display Structure .....	16





## LIST OF TABLES

1. FLL-716 Front Panel LEDs.....	3
2. 32-Channel HDSL Transmission Distances.....	6
3. RS-232 Connector Pin Assignments .....	9
4. PG-Flex Craft Port Data Interface.....	10
5. Main Menu Options.....	18
6. System Settings Menu Options .....	20
7. ISDN Channel Unit Configuration Options .....	23
8. Channel Configuration Options.....	24
9. HDSL Status Screen Options .....	27
10. Metallic Access Menu Options .....	32
11. Inventory Menu Definitions .....	35
12. FLL-716 COT Line Unit Troubleshooting.....	36



# PRODUCT OVERVIEW

This section describes the ADC® PG-Flex® FLL-716 List 3C Central Office Terminal (COT) Line Unit and defines its features and specifications.

## DESCRIPTION AND FEATURES

The FLL-716 List 3C COT line unit is the Central Office (CO) end of the PG-Flex subscriber carrier system, and resides in a ADC 19-inch COT shelf. The FLL-716 carries up to 32 subscriber channels between a COT and a Remote Terminal (RT). Each PG-Flex system in the COT shelf requires one FLL-716 which converts the CO battery to voltages necessary to operate the COT line units, channels units, and supplies power to the RT equipment. The FLL-716 Line Unit provides access through the RS-232 interface (craft port) to provision the PG-Flex system using an ASCII terminal. However, installing an FAU-728 List 2 Alarm Unit in the shelf disables the craft port on the FLL-716. The FAU-728 List 2 Alarm Unit then provides access through its craft port to provision the PG-Flex system using an ASCII terminal.

The FLL-716 uses ADC's High-bit-rate Digital Subscriber Line (HDSL) 2B1Q (2 binary 1 quaternary line code) technology to provide the equivalent of 2.048 Mbps digital transmission rates, plus signaling, over two copper pairs. The HDSL can include unterminated bridge taps, and is used without:

- using repeaters
- loop conditioning
- pair selection

The FLL-716 supports the use of PG-Flex doublers (FDU-452) to extend the range of a PG-Flex subscriber carrier system to 21.4 kft (6.6 km) with 24 AWG loops, or 16.2 kft (5.0 km) with 26 AWG loops. Two doublers can triple the range to 32.1 kft (9.9 km) with 24 AWG loops, or to 24.3 kft (7.5 km) with 26 AWG loops.

The FLL-716 supports:

- 32 subscriber channels
- PG-Flex doublers in systems transporting POTS and ISDN circuits
- 4Tel compatible Loop Test Systems
- ISDN channel units
- loop start and ground start channel units

# FRONT PANEL

Figure 1 shows the FLL-716 front panel. Table 1 on page 3 lists the indicators and status for the front panel LEDs.

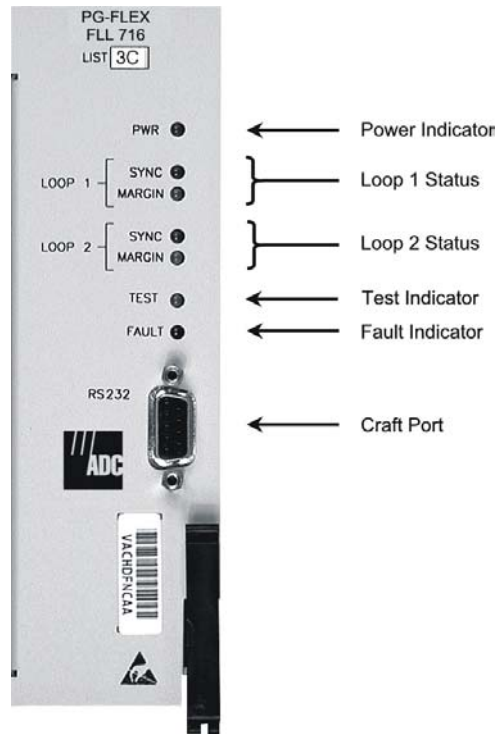

**Figure 1.** FLL-716 Front Panel

**Table 1.** FLL-716 Front Panel LEDs

<b>LED</b>	<b>LED States</b>	<b>Indicates</b>
PWR	Solid Green	Power is applied and line feed is operating normally.
	Flashing Green	Power is applied to the RT and testing for overloads.
	OFF	Not receiving power. COT Line Unit fuse may be blown.
LOOP 1 SYNC	Solid Green	HDSL line 1 is in sync between the COT and RT.
	Flashing Green	HDSL line 1 is attempting to sync with RT.
	OFF	HDSL line 1 does not detect an active RT.
LOOP 1 MARGIN	Solid Yellow	HDSL line 1 is below present margin threshold.
	OFF	HDSL line 1 margin is above the preset margin threshold.
LOOP 2 SYNC	Solid Green	HDSL line 2 is in sync between the COT and RT.
	Flashing Green	HDSL line 2 is attempting to sync with RT.
	OFF	HDSL line 2 does not detect an active RT.
LOOP 2 MARGIN	Solid Yellow	HDSL line 2 is below present margin threshold.
	OFF	HDSL line 2 margin is above the margin threshold.
TEST	Flashing yellow	Metallic access in progress.
	OFF	No metallic access active in system.
FAULT	Solid Red	A fault has been detected in the FLL-716.
	OFF	No faults have been detected in the FLL-716.

---

# SPECIFICATIONS

## Electrical Characteristics

Input Voltage	-40 to -72 Vdc
Input Power	145 W (maximum)
Input Protection	Fuse (3A GMT)
Output Voltage	±130 Vdc (maximum) ground fault protected
Output Power	100 W (maximum)

## Environmental Characteristics

Operating Elevation	-200 to 13,000 ft (-60 to 4000 m)
Operating Temperature & Humidity	-40 to +150 °F (-40 to +65 °C) 5% to 95% (non-condensing)

## Physical Dimensions

Height:	6.75 in. (17.1 cm.)
Width:	2.00 in. (5.1 cm.)
Depth:	10.50 in. (26.7 cm.)
Weight	2.0 lb. (0.91 kg.)

# FUNCTIONAL DESCRIPTION

This section provides an overview of a PG-Flex system, how HDSL technology is used to provide 32 DS0 channels, and how a subscriber drop is connected to a metallic bypass pair.

## OVERVIEW

PG-Flex is a small-capacity, universal subscriber carrier system supporting up to 32 DS0 channels of Plain Old Telephone Service (POTS), including Loop Start (LS) or Ground Start (GS) and Integrated Services Digital Network (ISDN) services.

A PG-Flex system is comprised of one line unit and one (or more) channel units at both the CO and the RT (see Figure 2). Line units and channel unit(s) can be hot-swapped without affecting other systems in the same shelf. The POTS channel units use a Pulse Coded Modulation (PCM) encoding scheme that allows high-speed modem and group 3 facsimile operation on all channels.

The CO side of a PG-Flex system mounts into a COT shelf and supports up to two systems. An Alarm Unit (common to all systems installed in the shelf) provides an interface for maintenance alarm relays and metallic access to the remote subscriber lines.

The RT side of a PG-Flex system mounts into an FRE-765 RT enclosure and supports one system, which includes one line unit and up to four channel units. The RT line unit includes the HDSL transceivers and converts the line power from the COT into the voltages required by the remote terminal electronics. The channel units must be the same type of card as the channel units installed at the CO.

Power is supplied from the CO to the RT over the HDSL transmission lines. The maximum distance from the CO to the RT is 10.7 kft (3.3 km) using 24 AWG (0.5 mm) cable. (Refer to the section "HDSL Transmission" for more information.)

Although 32 POTS subscribers can be connected to a 32 channel PG-Flex system, line powering limitations restrict service to a maximum of 24 subscribers simultaneously off-hook, or a maximum of 21 subscribers simultaneously off-hook while ringing up to 15 Ringer Equivalency Number (REN) of ringers.

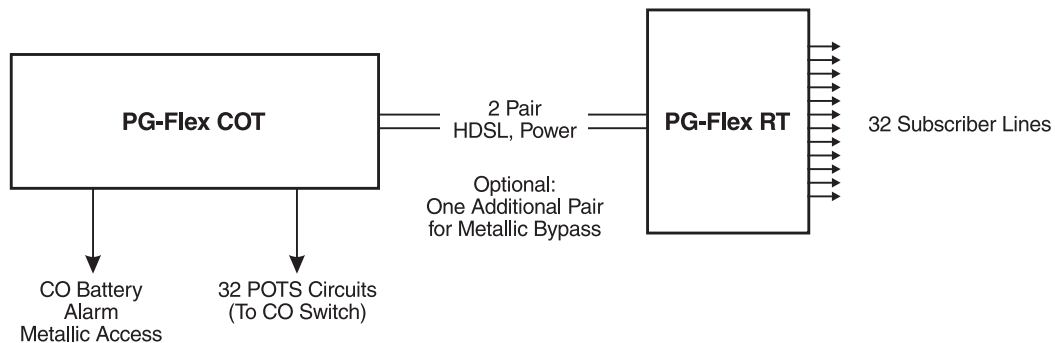

**Figure 2.** Typical PG-Flex Configuration

## HDSL TRANSMISSION

PG-Flex uses HDSL transmission technology between the COT and RT. This technology provides up to 32 DS0s, plus signaling, over two copper pairs without using repeaters, loop conditioning, or pair selection. Adaptive equalization, scrambling, and a four-level 2B1Q line coding increase range and minimize crosstalk. Because of HDSL transmission technology, the HDSL lines require no special conditioning and may include unterminated bridge taps, but cannot include load coils.

The line interface is a two-pair, 1110-kbps full-duplex 2B1Q transmission format. The dual HDSL lines provide 32 channels at 64-kbps, with signaling and an operations channel for management control. The signal characteristics on the carrier pairs comply with TR-NWT-001210, *Generic Requirements for High-bit-rate Digital Subscriber Line (HDSL) Systems*.

The distance limitation for HDSL transmission is based on a maximum signal attenuation of 35 dB. Since signal attenuation decreases as cable size increases, the larger the gauge, the greater the distance between the FLL-716 List 3C COT shelf and the RT enclosure. [Table 2](#) identifies these distances (at a cable temperature of 68 °F).

**Table 2.** 32-Channel HDSL Transmission Distances

Gauge	Loop Length	Resistance
19 AWG 0.9 mm	19.4 kft 5.9 km	322 $\Omega$
22 AWG 0.6 mm	13.7 kft 4.2 km	457 $\Omega$
24 AWG 0.5 mm	10.7 kft 3.3 km	569 $\Omega$
26 AWG 0.4 mm	8.1 kft 2.5 km	686 $\Omega$

## SUBSCRIBER DROP TESTING

For subscriber drop testing from the CO, PG-Flex is able to select and connect any subscriber drop to a metallic bypass pair at the RT. The PG-Flex system extends this connection back to the COT where it switches it to the test jack on the FAU-728 Alarm Unit and to the corresponding subscriber line on the COT channel card.

Metallic access is performed by momentarily placing and removing +116 Vdc (from the CO) on the subscriber's Tip lead. (The Ring lead should be between GND and the Tip value.) With POTS, LS/GS, and ISDN channel cards, the selected subscriber drop (assuming there is a working metallic bypass pair) connects to the corresponding COT subscriber line. The metallic connection drops when -116 Vdc is momentarily placed then removed from the subscriber's COT Tip lead.

Metallic access can also be activated through an ASCII terminal connected to the craft port located on the front of the FLL-716 List 3C line unit or through the FAU-728 List 2 Alarm Unit. (Refer to see "Metallic Access" on page 32 for metallic access test procedures.)



## OPERATIONAL CAPABILITIES

Figure 3 shows a block diagram of the FLL-716 List 3C. The power supply converts CO battery into voltages necessary to power the PG-Flex electronics including  $\pm 130$  Vdc. During power-up, the system checks the HDSL lines for hazardous conditions or other line faults which might affect the system. If a fault condition is detected, the system stops the power-up sequence and the LED indicators on the front panel indicate a line fault problem.

The FLL-716 provides the following functions for each 32 channel system in a single COT shelf:

- system power supply
- HDSL line transceivers and duplex RT power
- front-panel status indicators
- RS-232 craft port interface (DCE)
- switched access to the metallic bypass pair

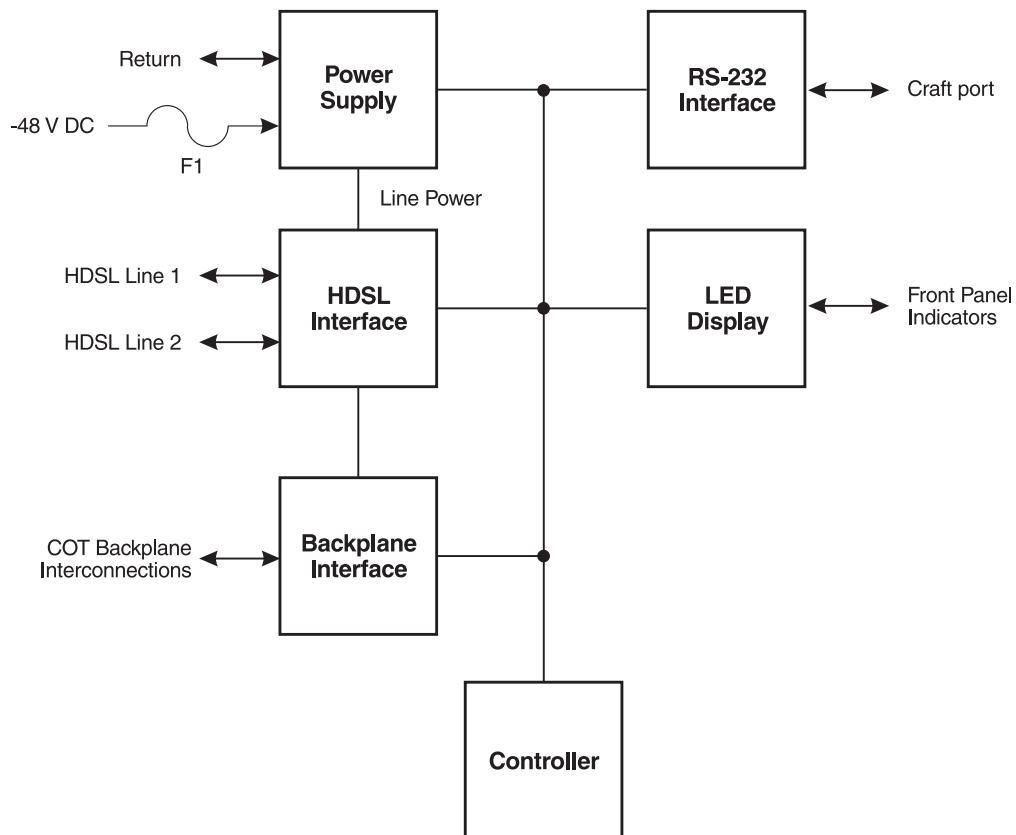

**Figure 3.** FLL-716 Block Diagram

# INSTALLATION AND CONFIGURATION

## UNPACKING

Upon receipt of the equipment, proceed as follows.

- 1 Unpack each container and visually inspect it for signs of damage. If the equipment has been damaged in transit, immediately report the extent of damage to the transportation company and to ADC. Order replacement equipment if necessary.
- 2 Check the contents versus the packing list to ensure complete and accurate shipment. If the shipment is short or irregular, contact ADC as described in the Product Support section. When storing the equipment for a prolonged period, use its original container.

## INSTALLATION



**Observe normal electrostatic discharge precautions when handling electronic equipment. Do not hold electronic plugs by their edge. Do not touch components or circuitry.**

**An FAU-728 List 2 (or higher) Alarm Unit must be installed at all times when ISDN channel units are installed. These units provide the composite clock reference source for the ISDN channel units that is required for normal operation of the ISDN channel units. Removing the FAU-728 List 2 Alarm Unit during an ISDN call for more than one minute may terminate the call.**

Install a FLL-716 COT line unit and verify operation as follows.

- 1 Insert the FLL-716 COT line unit into the COT shelf and verify the following:
  - a All LEDs on the Line Card turn on for about one-half second, then turn off.
  - b PWR and FAULT LEDs turn on after ten seconds, the COT starts its power management routine, and the PWR LED flashes.



**If line powering fails, the FLL-716 waits five minutes before attempting to repower the HDSL line. If line powering succeeds, HDSL communications begins synchronization and LOOP 1 SYNC and LOOP 2 SYNC flash.**

- 2 Verify the following front panel indications after the system powers up and establishes HDSL synchronized communications, and when no calls are in progress.
  - POWER is on
  - LOOP 1 SYNC is on
  - LOOP 1 MARGIN is off
  - LOOP 2 SYNC is on
  - LOOP 2 MARGIN is off
  - TEST is off
  - FAULT is off
- 3 Measure the following voltages on the COT shelf backplane.
  - -65 to -130 Vdc ( $\pm 10\%$ ) between the HDSL\_T1 pin and chassis ground
  - +65 to +130 Vdc between the HDSL\_T2 pin and chassis ground

## TERMINAL MANAGEMENT

The terminal management function allows configuration of and access to the entire PG-Flex system using an ASCII terminal (or modem with a null modem cable) connected to the craft port.

Use this function to:

- display system status
- set configuration parameters
- set metallic access connection to the subscriber circuit
- monitor system performance
- obtain an inventory report

### Connecting the FLL-716 to an ASCII Terminal or Modem

Table 3 identifies the connector terminations, signal designations, and signal sources used when connecting a terminal, a computer with terminal-emulation software, or a modem to the PG-Flex craft port.

**Table 3.** RS-232 Connector Pin Assignments

Connector		Signal Designation			Source
DB-25	DB-9	Function	Label	EIA	ADC
1	–	Shield		Shield	(not used)
2	3	Transmitted Data	TxD	DTE	Terminal or Modem
3	2	Received Data	RxD	DCE	PG-Flex
4	7	Request to Send	RTS	DTE	(not used)
5	8	Clear to Send	CTS	DCE	(not used)
6	6	Data Set Ready	DSR	DCE	PG-Flex
7	5	Signal Ground	SG	Common	Common
8	1	Carrier Detect	CD	DCE	Modem
20	4	Data Terminal Ready	DTR	DTE	Terminal or Modem
22	9	Ring Indicator	RI	DCE	(not used)



**Shaded signals are not used by PG-Flex, and these pins are unterminated.**

**DCE = Data Communications Equipment.**

**DTE = Data Terminal Equipment.**

The data interface supported by PG-Flex is defined in Table 4. PG-Flex automatically sets the data rate for the craft port after it receives several carriage return characters (corresponding to **ENTER** from the keyboard) from the terminal or modem.

**Table 4.** PG-Flex Craft Port Data Interface

Parameter	Value
Connector	DB-9 (female)
Transmission	Asynchronous
Data Rate	1.2 kbps 2.4 kbps 4.8 kbps 9.6 kbps
Data Rate Selection	Automatic
Data Bits	8
Stop Bits	1
Parity	None

Figure 4 and Figure 5 show the connections required between the PG-Flex craft port and an ASCII terminal (or computer running terminal-emulation software) equipped with DB-9 and DB-25 connectors (respectively).

To support automatic logoff from the PG-Flex craft port when the ASCII terminal is unplugged from the craft port, Data Terminal Ready (DTR) must be connected between the craft port and the ASCII terminal. If this connection is not made, the technician must manually log off the PG-Flex session before disconnecting the terminal.



**Failure to observe the above precautions can compromise security. Specifically, the next person accessing the PG-Flex system could enter the system at the same point where the previous user exited, thus bypassing the logon and password screens.**

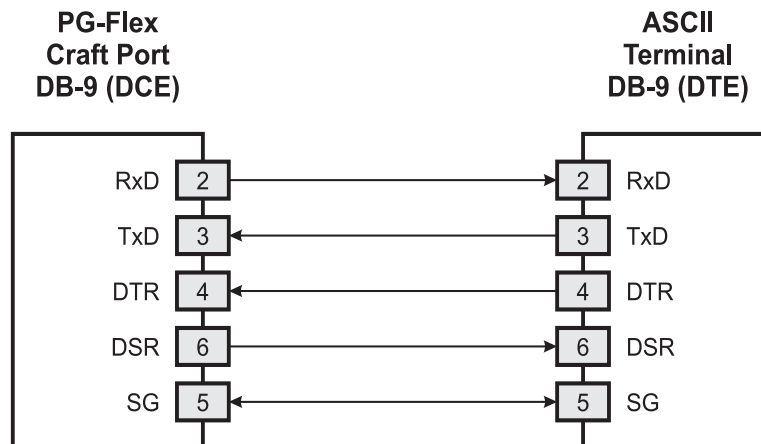

**Figure 4.** PG-Flex to Terminal (DB-9)

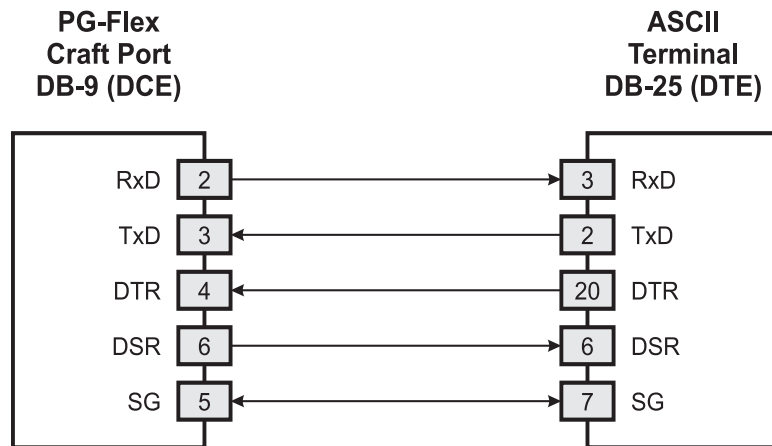

Figure 5. PG-Flex to Terminal (DB-25)

Figure 6 shows the connections required between the PG-Flex craft port and a modem equipped with a DB-25 connector. Because both the PG-Flex and modem are considered DCE devices, a null-modem cable must be used.

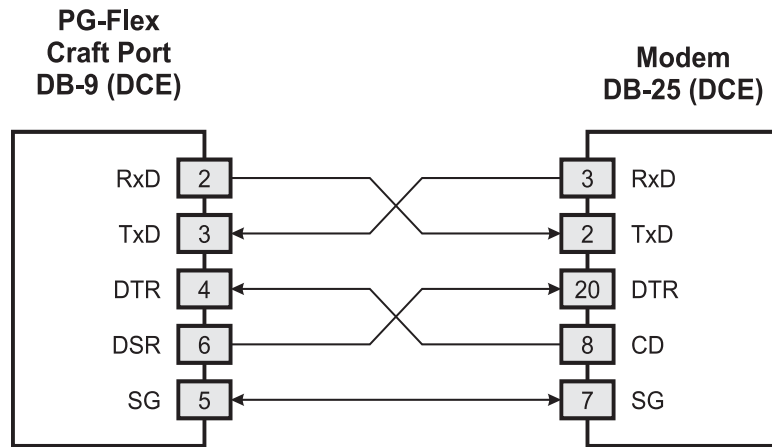

Figure 6. PG-Flex to Modem (DB-25)

The modem must be configured to enable monitoring of the DTR lead and to provide control of the CD lead to support automatic logoff from the PG-Flex craft port. If the modem is not properly configured, the technician must manually log off the PG-Flex session before terminating the call. This prevents the next user from continuing the same session.

The modem's DTR input must be connected to the Data Set Ready (DSR) output of the PG-Flex craft port through the null-modem cable. When the PG-Flex system automatically logs off after a programmable period of inactivity on the craft port, its DSR lead signals the modem (through the modem's DTR lead) to disconnect the call.

Also, the modem's CD output lead must be connected to the craft port's DTR input lead through the null-modem cable. When the originating terminal disconnects the call, the modem's CD lead signals the PG-Flex system (through the craft port's DTR lead) to perform an automatic logoff.

If the modem is not configured correctly and a null-modem cable (wired as shown in [Figure 6](#)) is not used between the PG-Flex craft port and modem, the next person to access the PG-Flex system can enter the system at the same point the previous user left the system, thereby bypassing the logon and password screens.

## Connecting the ASCII Terminal to the FAU Card

To test the system, the ASCII terminal can be connected to either the FAU card (if present) or the FLL-716 line unit.

### Connection through the FAU card

If the FAU card is present, plug the cable into the FAU craft port and observe the indicator lights to ensure the card is working properly.

- 1 After connecting the ASCII terminal to the FAU-728 alarm unit, press **ENTER** several times to start the autobaud feature. Autobaud covers transmission rates of 1200, 2400, 4800 and 9600 bps only. The Power-Up and Connection screen is displayed.



- 2 Press **ENTER** again and the logon screen appears.



- 3 Enter the password, which the screen echoes as a series of asterisks, then press **ENTER** to display the Main Menu for the FAU card.

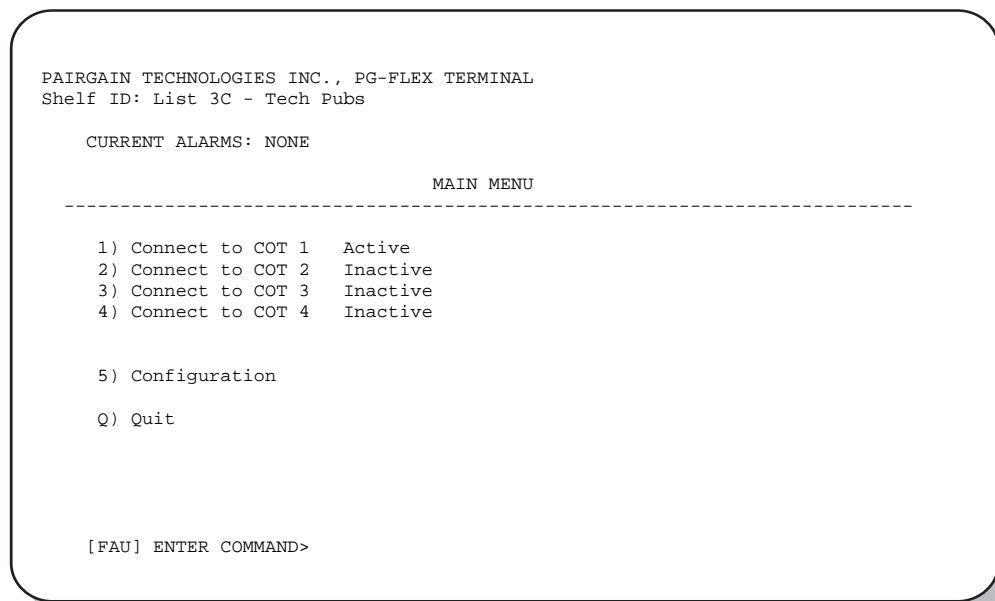

- 4 Choose one of the COTs by typing its number. Then press **ENTER** to display the Main Menu for the selected COT. Proceed as described in the following section.

### Connection through the FLL-716 Line Unit

- 1 If an FAU-728 List 2 Alarm Unit is not installed, connect the ASCII terminal to the FLL-716 line unit and press **ENTER** several times to start the autobaud feature. Autobaud covers transmission rates of 1200, 2400, 4800, and 9600 bps only. The Power-Up and Connection screen is displayed.



- 2 Press **ENTER** to display the logon screen.

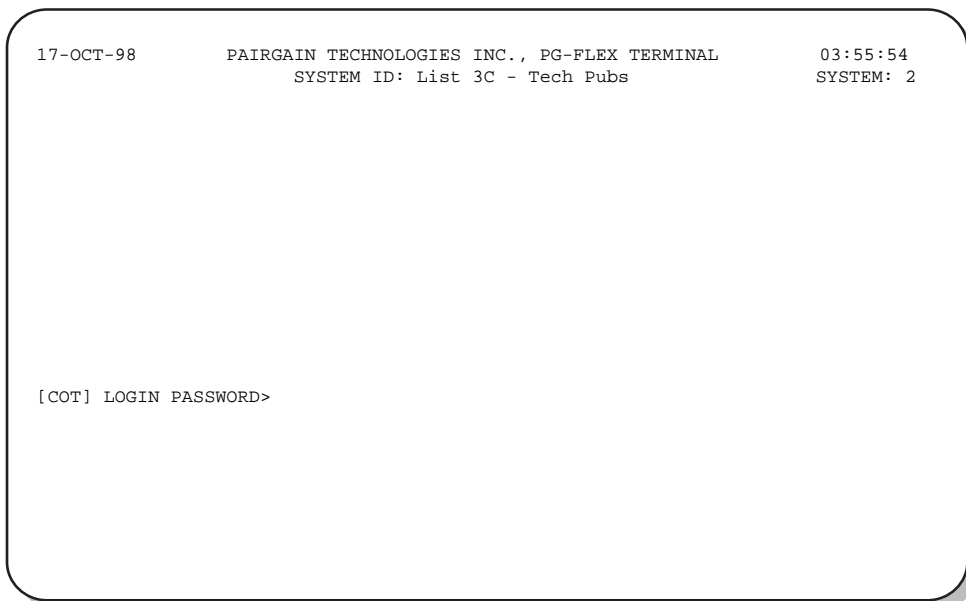

**The autobaud feature supports transmission rates of 1200, 2400, 4800 and 9600 bps only.**

- 3 Enter the password. For security reasons, the system echoes the password with asterisks (\*). Press **ENTER**.





To obtain a forgotten logon password, contact the Customer Service Engineering group (see Technical Support) for access using a master password.

## System Time Screen

The System Time screen appears the first time you log on or after the power has been removed from the COT shelf. Enter the new system time in hours (HH), minutes (:MM), and seconds (:SS).

```
08-OCT-98          PAIRGAIN TECHNOLOGIES INC., PG-FLEX TERMINAL          0:00:24
                   SYSTEM ID: List 3C - Tech Pubs                      SYSTEM: 1

                   SYSTEM TIME
                   -----

System Time has NOT been initialized!!

[COT] ENTER NEW SYSTEM TIME (HH:MM[:SS]):
```

This screen does not appear the next time you log on unless the power has been removed. Press **ENTER** to display the Main Menu.

# CONFIGURATION, MAINTENANCE, AND TESTING

The following sections describe how to navigate the ASCII screens to configure, check the status of, and maintain the FLL-716 system.

## Menus and Display Structure

Figure 7 shows the menu structure of the terminal management system.

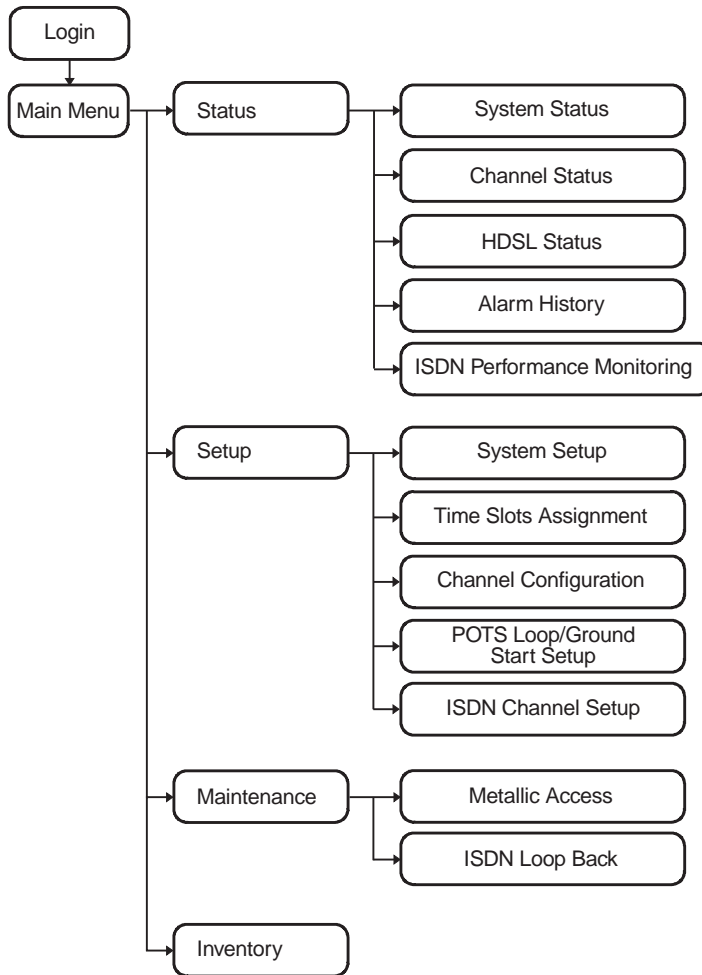

Figure 7. Terminal Menu and Display Structure

## Main Menu

The Main Menu provides access to other menus to configure the PG-Flex system, initiate or display metallic access connections, and display status information.

```
17-OCT-98          PAIRGAIN TECHNOLOGIES INC., PG-FLEX TERMINAL          03:55:54
                   SYSTEM ID: List 3C - Tech Pubs                      SYSTEM: 2

CURRENT STATUS: OK                                LOGGED IN: COT
ALARMING TERMINAL: NONE

                                MAIN MENU
-----

                                A) STATUS
                                B) SETUP
                                C) MAINTENANCE
                                D) INVENTORY

                                Q)uit

[COT] ENTER COMMAND>
```

Table 5 describes the Main Menu options.

**Table 5. Main Menu Options**

<b>Main Menu Option</b>	<b>Function</b>
A) Status	<ul style="list-style-type: none"> <li>• System Status shows the equipment installed in the system and the current status (in alarm or not) of the equipment.</li> <li>• Channel Status shows the current status of all channels in the system. Each channel has a status condition. Status conditions vary for the different types of channel cards. Examples of status are:            IDLE: channel is not off-hook or ringing            RING: channel is ringing            BUSY: channel is off-hook            OPEN: no connection to CO switch            TEST: in test mode            TREQ: 116 Vdc test request            SERR: PCM bus frame sync error            FIDL: forced idle            TDSB: time slots disabled            RBAT: reverse battery            ****: unknown</li> <li>• HDSL Status shows the status of the HDSL span, listing either a 24-hour or 7-day performance history.</li> <li>• Alarm History displays the status history of COT, RT, and span alarms.</li> <li>• ISDN Performance Monitoring Menu displays PM error count and PM threshold for a specific ISDN card and channel.</li> </ul>
B) Setup	Display the current setup or set or change the following configurable items: <ul style="list-style-type: none"> <li>• System Setup</li> <li>• Time Slots Assignment (view only)</li> <li>• Channel Configuration</li> <li>• POTS Loop/Ground Start Setup</li> <li>• ISDN Channel Setup</li> </ul>
C) Maintenance	Set up a metallic access connection to a subscriber circuit or perform an ISDN loop back test for a PG-Flex system. Metallic Access includes: COT bridging, COT looking in, COT looking out, RT looking out, RT looking in, RT bridging, and subscriber bypass. ISDN loopback testing includes the ability to switch between COT and RT loopback and change the loopback mode for each card and channel.
D) Inventory	Display manufacturing information and version information for all the units in the system (except the FAU/FPI unit). At the CO line unit terminal or the RT line unit terminal, the command displays all units in the system.
Q) Quit	Logs the user off.

## Configure System Settings

To perform system setup:

- 1 On the Main Menu, type **B** then press **ENTER** to display the Setup Menu.

```

17-OCT-98          PAIRGAIN TECHNOLOGIES INC., PG-FLEX TERMINAL          03:59:46
                   SYSTEM ID: List 3C - Tech Pubs                      SYSTEM: 2

CURRENT STATUS: OK LOGGED IN: COT
ALARMING TERMINAL: NONE

-----

                        SETUP MENU
-----

A) SYSTEM SETUP
B) TIME SLOTS ASSIGNMENT
C) CHANNEL CONFIGURATION
D) POTS LOOP/GROUND START SETUP
E) ISDN CHANNEL SETUP

CTRL-X) Main Menu    e(X)it

[COT] ENTER COMMAND>

```

- 2 Type **A** then press **ENTER** to display the System Settings menu.

```

17-OCT-98          PAIRGAIN TECHNOLOGIES INC., PG-FLEX TERMINAL          03:59:52
                   SYSTEM ID: List 3C - Tech Pubs                      SYSTEM: 2
                   SYSTEM SETTINGS
-----

A) SYSTEM DATE: . . . . . 17-OCT-98
B) SYSTEM TIME: . . . . . 03:59:52
C) SYSTEM ID: . . . . . List 3C - Tech Pubs
D) SET PASSWORD . . . . .
E) AUTO LOGOUT TIME (min.): . . . DISABLED (DISABLED,5,30,60)
F) METERED TONE FREQUENCY (kHz): DISABLED (DISABLED,12,16)
G) RING FREQUENCY (Hz): . . . . 20 (20,25,30)
H) HDSL ES ALARM THRESHOLD: . . . DISABLED (DISABLED,17,170)
I) HDSL MARGIN THRESHOLD: . . . 11 (0-15,0=DISABLED)
J) ALARM ON HDSL THRESHOLD: . . . DISABLED (DISABLED,ENABLED)
K) LOCAL LOOP LENGTH: . . . . . LONG (SHORT, LONG)
L) ALARM ON CONFIGURATION: . . . MINOR (DISABLED, MINOR, MAJOR)
M) ALARM ON INSUFFICIENT TIMESLOT: DISABLED (DISABLED, ENABLED)
N) ALARM ON ISDN PM THRESHOLD: . . DISABLED (DISABLED, ENABLED)

CTRL-X) Main Menu    e(X)it



[COT] ENTER CHOICE>

```

- 3 Type a letter (**A** through **N**) then press **ENTER** to select a parameter to change. Refer to [Table 6](#) for System Settings menu options.

A separate screen appears for the parameter selected.

**Table 6. System Settings Menu Options**

Parameter	Default Value	Description
A) System Date	01-JAN-00	Enter date. (This product meets or exceeds the current technical quality requirements for Year 2000 compliance and properly processes dates up to and beyond December 31, 1999.)
B) System Time	00:00:00 at power on	Enter military time (hh:mm:ss). The System Time must be set individually for each PG-Flex system. The time setting is lost whenever the system shelf loses power or the COLU or RTL module is removed and reinserted.
		<p><b>All the parameters discussed in the remainder of this table are stored in the CO line unit card NVRAM, and therefore normally do not change when power is cycled or cards are removed and reinserted.</b></p>
C) System ID	(all spaces)	Indicate the physical location of the PG-Flex system (CO or RT terminal) using any combination of up to 24 alphanumeric characters (including upper case, lower case, numerals, and punctuation marks). Each PG-Flex system should be assigned a unique, System ID. The default for System ID is “blank” (all spaces). If the CO line unit is replaced, re-enter the appropriate system ID.
D) Set Password	(all spaces)	Enter the password. The password can be up to 10 characters (including spaces), or any combination of alphanumeric characters (including upper case, lower case, numerals, and punctuation marks). This parameter is stored in the CO line unit card NVRAM and therefore does not change when power is cycled or cards are removed and reinserted. The password default is <b>ENTER</b> .
E) Auto Logout Time	DISABLED	The system automatically logs off after a time determined by this parameter: <ul style="list-style-type: none"> <li>• DISABLED: The user is never automatically logged off.</li> <li>• 5: 5 minutes.</li> <li>• 30: 30 minutes.</li> <li>• 60: 60 minutes.</li> </ul>
		<p><b>If the user leaves the system without logging off, and if Auto Logout Time is “DISABLED,” the next person who accesses the system can do so without logging on and does not need a password.</b></p>
F) Meter Tone Frequency	12	Meter tones are used for out-of-band signaling with coin telephones, typically in international markets. A special channel card is required to support this function. <ul style="list-style-type: none"> <li>• 12: 12 kHz.</li> <li>• 16: 16 kHz.</li> </ul>
G) Ring Frequency	20	Determines the frequency of the ringing voltage on all subscriber lines: <ul style="list-style-type: none"> <li>• 20: 20 Hz.</li> <li>• 25: 25 Hz.</li> <li>• 30: 30 Hz.</li> </ul>
H) HDSL ES Alarm Threshold	DISABLED	Sets the number of Error Seconds required before a minor alarm is generated (dependent on the setting of the Alarm on HDSL Threshold parameter). The count of Error Seconds is reset to zero when the reset function is used on the HDSL Performance History status screen. <ul style="list-style-type: none"> <li>• DISABLED: No minor alarm is generated, regardless of the number of error seconds.</li> <li>• 17: A minor alarm is generated after 17 error seconds.</li> <li>• 170: A minor alarm is generated after 170 error seconds.</li> </ul>

**Table 6. System Settings Menu Options**

Parameter	Default Value	Description
I) HDSL Margin Threshold	4	<p>Sets the HDSL margin threshold. If the HDSL margin attains a value equal to or less than the setting for this parameter, a minor alarm is generated (determined by the Alarm setting on HDSL Threshold parameter).</p> <p>A default setting of 4 indicates that a minor alarm occurs when the HDSL margin is 4 dB.</p> <p>The HDSL Margin Threshold can be set between 1 dB and 15 dB.</p>
J) Alarm on HDSL Threshold	DISABLED	<p>Controls whether a minor alarm is generated if the HDSL ES Alarm Threshold or HDSL Margin Threshold is exceeded.</p> <ul style="list-style-type: none"> <li>• <b>DISABLED:</b> A minor alarm does not occur when the HDSL ES Alarm Threshold and/or HDSL Margin Threshold is exceeded.</li> <li>• <b>ENABLED:</b> A minor alarm occurs when the HDSL ES Alarm Threshold and/or HDSL Margin Threshold is exceeded.</li> </ul>
K) Local Loop Length	Long	<p>Determines the length of subscriber loop supported by PG-Flex and affects all subscriber loops within a single PG-Flex system. The loop length affects the total power required by the PG-Flex system: the shorter the loop, the less the power required.</p> <ul style="list-style-type: none"> <li>• <b>LONG:</b> The PG-Flex system can support subscriber loops with a line resistance of 530 <math>\Omega</math> or less.</li> <li>• <b>SHORT:</b> The PG-Flex system can support subscriber loops with a line resistance of 400 <math>\Omega</math> or less.</li> </ul> <p>For most applications, the power saved by the SHORT setting is relatively insignificant; therefore, select the default value (LONG) in most cases.</p>
L) Alarm on Configuration	DISABLED	<p>Each channel card in a PG-Flex system must have a corresponding channel card type at the opposite node. A mismatch condition results when a card does not have the correct corresponding card at the other end due to channel unit removal, type mixing, or failure. If a mismatch condition exists between the CO and RT, replace the corresponding channel unit with a matching channel unit.</p> <ul style="list-style-type: none"> <li>• <b>DISABLED:</b> A minor alarm does not occur if there is a mismatch of channel units.</li> <li>• <b>ENABLED:</b> A minor alarm occurs if there is a mismatch of channel units.</li> </ul>
M) Alarm on Insufficient Time Slot	DISABLED	<p>The system can generate a minor alarm if more circuits are enabled than there are time slots available. (This could occur when enabling ISDN circuits without first disabling a sufficient number of POTS circuits to ensure that there are enough time slots available to support the ISDN circuits.)</p> <ul style="list-style-type: none"> <li>• <b>DISABLED:</b> A minor alarm does not occur if more circuits have been enabled than there are available time slots.</li> <li>• <b>ENABLED:</b> A minor alarm occurs if more circuits have been enabled than there are available time slots.</li> </ul>
N) Alarm on ISDN PM Threshold	DISABLED	<p>This parameter determines whether a minor alarm occurs if any of the PM thresholds are exceeded.</p> <ul style="list-style-type: none"> <li>• <b>DISABLED:</b> A minor alarm does not occur if any of the ISDN PM thresholds are exceeded.</li> <li>• <b>ENABLED:</b> A minor alarm occurs if any of the ISDN PM thresholds are exceeded.</li> </ul>

### Configure an ISDN Channel Unit

- 1 Type **E** then press **ENTER** to display the ISDN Channel Setup selection screen.

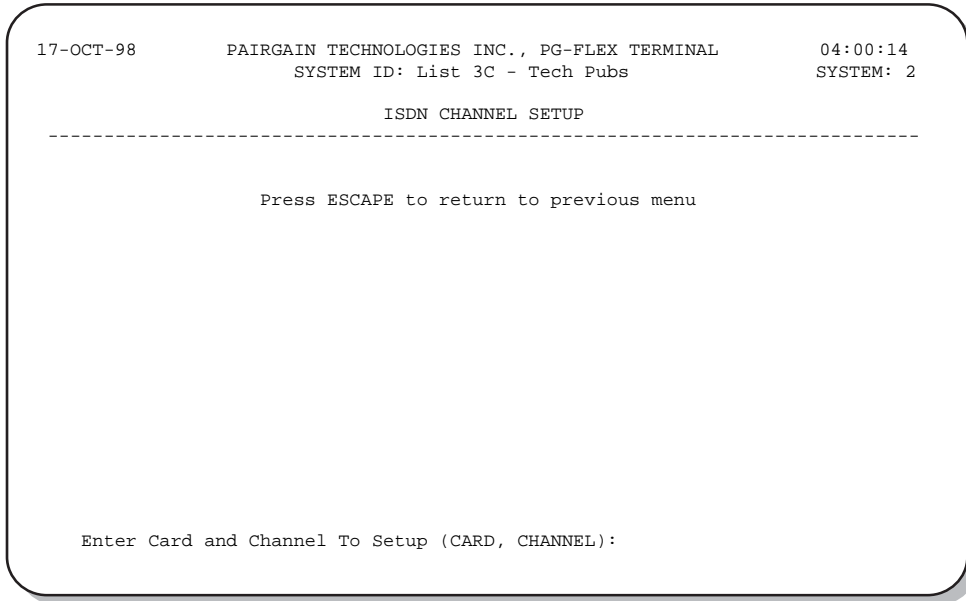

**If no ISDN cards are installed in the PG-Flex system, the display indicates, and prevents access to the ISDN Channel Setup menu.**

- 2 Type the card number followed by a comma. Then type the channel number for the ISDN circuit being configured, then press **ENTER** (for example, "1,2") to display the ISDN Channel Setup menu.

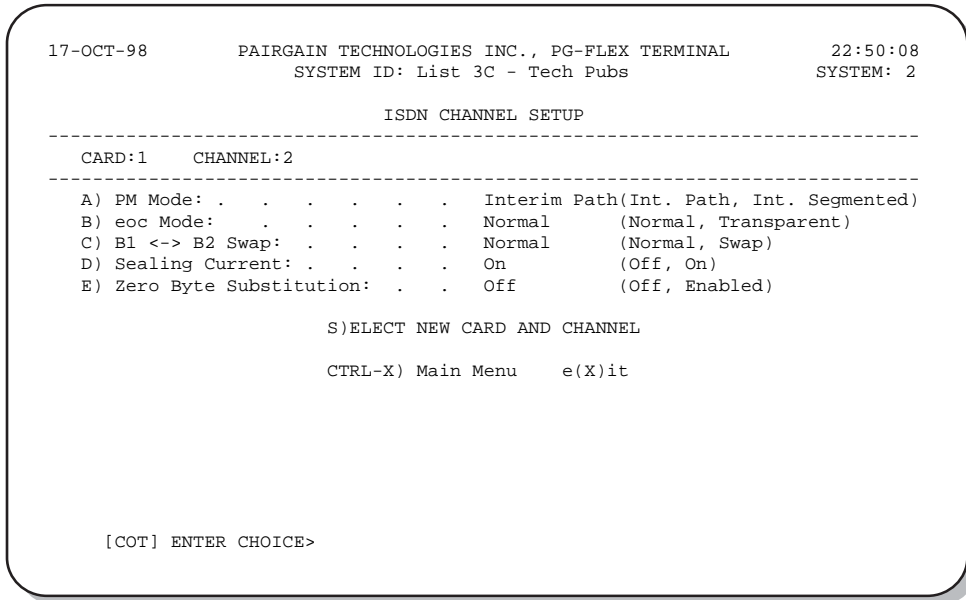

When finished with the System Setting Menu Options, type **X** to return to the Setup Menu.



- 3 On the ISDN Channel Setup menu, type a letter (A through E) then press **ENTER** to choose a setup parameter. Select one of the two options available for each parameter (Table 7).

*Table 7. ISDN Channel Unit Configuration Options*

Parameter	Default Value	Description
A) PM Mode	Interim	Method of performance monitoring. <ul style="list-style-type: none"> <li>Interim Performance: Considers the channel as one path and collects the end-to-end error rate for the entire transport path.</li> <li>Segmented Performance: Considers the channel as separate sections and individually collects error rates for each DSL loop.</li> </ul>
B) eoc mode	Normal	How ISDN eoc (embedded operations channel) messages are handled by the PG-Flex system. <ul style="list-style-type: none"> <li>Normal: eoc messages are decoded and retransmitted within the PG-Flex system.</li> <li>Transparent: eoc messages are not decoded and are passed through the PG-Flex system transparently.</li> </ul>
C) B1<-> B2 Swap	Normal	Whether the B channels are swapped between the PG-Flex CO ISDN "U" interface and the RT ISDN "U" interface. The "D" signaling channel is unaffected by this parameter. <ul style="list-style-type: none"> <li>Normal: channels "B1" and "B2" at the CO ISDN "U" interface are routed to channels "B1" and "B2" at the RT ISDN "U" interface.</li> <li>Swap: channels "B1" and "B2" at the CO ISDN "U" interface are routed to channels "B2" and "B1" at the RT ISDN "U" interface.</li> </ul>
D) Sealing Current	On	Whether sealing current is applied to the ISDN subscriber loop. <ul style="list-style-type: none"> <li>Off: No sealing current is applied to the ISDN subscriber loop.</li> <li>On: A constant current of approximately 5 mA flows in the ISDN subscriber loop at all times.</li> </ul>
E) Zero Byte Substitution	Off	How ISDN eoc messages are handled by the PG-Flex system. <ul style="list-style-type: none"> <li>Off: The PG-Flex system passes all data through without any special encoding.</li> <li>On: The PG-Flex system uses a ZBS code to prevent long string of zeros in the data.</li> </ul>

- 4 To choose a new ISDN channel unit and channel to configure, type **S** then press **ENTER**. Repeat steps 2 and 3.
- 5 When finished, type **X** then press **ENTER** to return to the Setup Menu.

## Channel Configuration



**32 time slots are available, with channels enabled by default. Disable channels only when the time slots are required by another channel unit.**

- 1 On the Setup Menu type **C** then press **ENTER** to access the Channel Configuration menu.

```

17-OCT-98          PAIRGAIN TECHNOLOGIES INC., PG-FLEX TERMINAL          11:55:50
                   SYSTEM ID: List 3C - Tech Pubs                      SYSTEM: 1

                   CHANNEL CONFIGURATION
-----
Channel COT      CU1      CU2      CU3      CU4      CU5      CU6
          RT (POTS8) (POTS8) (POTS8) (ISDN4) (---) (---)
-----
      1         ON       ON       ON       ON       -       -
      2         ON       ON       ON       ON       -       -
      3         ON       ON       ON       OFF      -       -
      4         ON       ON       ON       OFF      -       -
      5         ON       ON       ON       -        -       -
      6         ON       ON       ON       -        -       -
      7         ON       ON       ON       -        -       -
      8         ON       ON       ON       -        -       -

                   2 Time slots Available

                   D)isable Channel  E)nable Channel
                   CTRL-X) Main Menu  e(X)it

[COT] ENTER COMMAND>
    
```

See [Table 8](#) for channel configuration options.

**Table 8.** Channel Configuration Options

Parameter	Default Value	Function
Channel configuration	Enabled	Each channel is individually enabled or disabled through the COLU. This configuration is stored in both the COLU and the COCU. If any one card (COLU, RTLU, COCU, or RTCU) is removed, replaced, or reinserted, the Channel Configuration is automatically reserved. The values can be set to one of the following parameters: The display indicates when a channel is enabled but no slots are available. DISABLED (OFF): The selected channel is disabled (no time slot). ENABLED (ON): The selected channel is enabled (with time slot).

- 2 Each channel is individually enabled or disabled through the COLU. Type **D** to disable a channel or type **E** to enable a channel then press **ENTER**.
- 3 Enter the card number, a comma, then the channel number (for example, type “1,1” for card 1 on channel 1). Press **ENTER**.
- 4 When finished, type **X** then press **ENTER** to return to the Setup Menu.

## Display Time Slot Assignments

- 1 On the Setup Menu, type **B** then press **ENTER** to display the Time Slots Assignment screen.

```

17-OCT-98          PAIRGAIN TECHNOLOGIES INC., PG-FLEX TERMINAL          03:59:56
                   SYSTEM ID: List 3C - Tech Pubs                      SYSTEM: 2

                   TIME SLOTS ASSIGNMENT
-----
TIME   CHANNEL   TIME   CHANNEL   TIME   CHANNEL   TIME   CHANNEL
SLOT   ASSIGNMENT  SLOT   ASSIGNMENT  SLOT   ASSIGNMENT  SLOT   ASSIGNMENT
-----
 1:   CU1  CH1    9:   CU2  CH1    17:   CU3  CH1    25:   CU4  CH1
 2:   CU1  CH2   10:   CU2  CH2   18:   CU3  CH2   26:   CU4  CH1
 3:   CU1  CH3   11:   CU2  CH3   19:   CU3  CH3   27:   CU4  CH1
 4:   CU1  CH4   12:   CU2  CH4   20:   CU3  CH4   28:   CU4  CH2
 5:   CU1  CH5   13:   CU2  CH5   21:   CU3  CH5   29:   CU4  CH2
 6:   CU1  CH6   14:   CU2  CH6   22:   CU3  CH6   30:   CU4  CH2
 7:   CU1  CH7   15:   CU2  CH7   23:   CU3  CH7   31:   ----
 8:   CU1  CH8   16:   CU2  CH8   24:   CU3  CH8   32:   ----
-----

                   CTRL-X) Main Menu      e(X)it

[COT] ENTER COMMAND>

```



The system automatically generates these values. However, cycling power to the system or hot plugging a new channel unit can change these values.

Because PG-Flex is a universal subscriber carrier system, the specific time slot assigned to a channel is irrelevant—this screen is provided for informational purposes only.

- 2 On the Time Slots Assignment screen, type **X** then press **ENTER** to return to the Setup Menu.

## Configure Loop Start/Ground Start Channel Units

- 1 On the Setup Menu, type **D** then press **ENTER** to display the POTS Ground/Loop Start Configuration menu.

```

17-OCT-98          PAIRGAIN TECHNOLOGIES INC., PG-FLEX TERMINAL          04:00:08
                   SYSTEM ID: List 3C - Tech Pubs                      SYSTEM: 2

POTS GROUND/LOOP START CONFIGURATION
-----
Channel COT      CU1      CU2      CU3      CU4      CU5      CU6
          (POTG8)  (---)   (POTS8)  (ISDN4)  (---)   (---)
          RT  (POTG8)  (POTS8)  (POTS8)  (ISDN4)
-----
  1      LOOP      -      LOOP      N/A      -      -
  2      LOOP      -      LOOP      N/A      -      -
  3      LOOP      -      LOOP      N/A      -      -
  4      LOOP      -      LOOP      N/A      -      -
  5      LOOP      -      LOOP      -        -      -
  6      LOOP      -      LOOP      -        -      -
  7      LOOP      -      LOOP      -        -      -
  8      LOOP      -      LOOP      -        -      -

          L) Change to Loop Start
          G) Change to Ground Start
          CTRL-X) Main Menu    e(X)it

[COT] ENTER COMMAND>
    
```

- 2 Type **L** then press **ENTER** to change the channel to loop start, or type **G** then press **ENTER** to change the channel to ground start. Enter the card and channel numbers.
- 3 When finished, type **X** then press **ENTER** to return to the Setup Menu.

## Display Doubler Status

Display the status for the doubler unit(s) through the HDSL Status screen.

- 1 On the Main Menu, type **A** then press **ENTER** to display the Status menu.
- 2 Type **C** then press **ENTER** to display the HDSL Status screen.

```

17-OCT-98          PAIRGAIN TECHNOLOGIES INC., PG-FLEX TERMINAL          03:56:42
                   SYSTEM ID: List 3C - Tech Pubs                      SYSTEM: 2

-----
                        HDSL STATUS
-----
ALARMS: NONE
-----
                COT HDSL-1   COT HDSL-2   RT HDSL-1   RT HDSL-2
                mn/cr/mx   mn/cr/mx   mn/cr/mx   mn/cr/mx
MARGIN (db):    12/12/13   12/13/13   10/10/11   11/12/12
PULSE ATTN (db):  31         30         32         32
PPM OFFSET (ppm):  0         0         -2         -2
24 HOUR ES:     1         1         2         2
24 HOUR UAS:    32        40         0         8
-----
                LAST CLEARED: NONE
-----

                A) 24-HOUR PERFORMANCE HISTORY
                B) 7-DAY PERFORMANCE HISTORY

                CTRL-X) Main Menu   (R)eset   e(X)it

[COT] ENTER COMMAND>

```

- 3 Type an option (Table 9) and, where appropriate, press **ENTER** to bring about one of the following.

**Table 9.** HDSL Status Screen Options

Option	Response
A	Shows the 24-hour performance history.
B	Shows the 7-day performance history.
CTRL-X	Exits the current screen and returns to the Main Menu.
R	Resets minimum and maximum margins, 24-Hour ES, 24-Hour UAS, and 24-Hour Performance History. Type <b>Y</b> to confirm the reset, or type <b>N</b> to cancel the reset.
X	Exits this screen and returns to Status Menu.

- 4 Type **X** then press **ENTER** to return to the Status Menu.



**When initially powering up or plugging in the board, select “Reset” to clear the minimum and maximum margins, as well as the 24-Hour ES, 24-Hour UAS, and 24-Hour Performance History.**

## Display Alarm History

- 1 On the Status Menu, select **D** then press **ENTER** to display the System Alarm History menu.

```

17-OCT-98      PAIRGAIN TECHNOLOGIES INC., PG-FLEX TERMINAL      03:57:32
                SYSTEM ID: List 3C - Tech Pubs                  SYSTEM: 2

                SYSTEM ALARM HISTORY
-----
LAST CLEARED:  ----
-----

                A) COT SHELF ALARM HISTORY
                B) RT SHELF ALARM HISTORY
                C) SPAN ALARM HISTORY

                CTRL-X) Main Menu  R)reset  e(X)it

[COT] ENTER COMMAND>
    
```



Upon initially powering up, select Reset to clear out the alarm history.

- 2 Type **C** then press **ENTER** to display the Span Alarm history.

```

17-OCT-98      PAIRGAIN TECHNOLOGIES INC., PG-FLEX TERMINAL      22:57:30
                SYSTEM ID: List 3C - Tech Pubs                  SYSTEM: 2

                SPAN-1 ALARM HISTORY
-----
Type           First           Last           Status        Current      Count
-----
HDSL1 UAS      OCT 17, 00:00  OCT 17, 00:00  Enabled       NONE         1
HDSL2 UAS      OCT 17, 00:00  OCT 17, 00:00  Enabled       NONE         1

                CTRL-X) Main Menu  e(X)it > (S)pan >
    
```

- 3 Type **S** then press **ENTER** to get the additional screens for the doubler spans.



The following Alarm History menu (Span 2) is only available when a doubler is present in the circuit.

```

17-OCT-98      PAIRGAIN TECHNOLOGIES INC., PG-FLEX TERMINAL      22:57:30
                SYSTEM ID: List 3C - Tech Pubs                SYSTEM: 2
                SPAN-2 ALARM HISTORY
-----
Type           First           Last           Status        Current      Count
-----
HDSL2 UAS     OCT 17, 00:00   OCT 17, 00:00   Enabled       NONE         1

CTRL-X) Main Menu  e(X)it > (S)pan >

```

## Display ISDN Performance Monitoring

- 1 On the Status Menu, type **A** then press **ENTER** to display the ISDN Performance Monitoring Menu.

```

17-OCT-98      PAIRGAIN TECHNOLOGIES INC., PG-FLEX TERMINAL      03:57:44
                SYSTEM ID: List 3C - Tech Pubs                SYSTEM: 2

                ISDN PERFORMANCE MONITORING MENU
-----

                Press ESCAPE to return to previous menu

Enter Card and Channel (CARD,CHANNEL):

```



If no ISDN cards are installed in the PG-Flex system, the display so indicates, and does not continue to the ISDN Channel Setup menu.

- 2 Type the card number followed by a comma. Then type the channel number for the ISDN module being configured, then press **ENTER** (for example, "1,2") to display the ISDN Channel Setup menu.
- 3 Enter the channel unit number and the channel for the new ISDN channel unit.

```

08-OCT-98      PAIRGAIN TECHNOLOGIES INC., PG-FLEX TERMINAL      12:45:18
                SYSTEM ID: List 3C - Tech Pubs                  SYSTEM: 1

                ISDN PERFORMANCE MONITORING MENU
-----
INTERIM PATH ENABLED  CARD:1  CHANNEL:2
-----

                A) SELECT NEW CARD AND CHANNEL
                B) PM ERROR COUNT
                C) PM THRESHOLD/ALERT INFO

                CTRL-X) Main Menu      e(X)it

[COT] ENTER COMMAND>
    
```

- 4 Type **B** then press **ENTER** to display the 8-Hour PM Error Count History screen.

```

17-OCT-98      PAIRGAIN TECHNOLOGIES INC., PG-FLEX TERMINAL      00:07:08
                SYSTEM ID: List 3C - Tech Pubs                  SYSTEM: 1
                8-HOUR PM ES COUNT HISTORY
-----
INTERIM PATH ENABLED  CARD:2  CHANNEL:1
-----

                CUSTOMER/NETWORK
                <<Hourly ES>>
                RT
-----
HOUR                COT
-----
16:00                0/ 0                0/ 0
17:00                0/ 0                0/ 0
18:00                0/ 0                0/ 0
19:00                0/ 0                0/ 0
20:00                0/ 0                0/ 0
21:00                0/ 0                0/ 0
22:00                0/ 0                0/ 0
23:00                0/ 0                0/ 0

                A) SELECT NEW CARD AND CHANNEL

                CTRL-X) Main Menu      e(X)it

[COT] ENTER COMMAND>
    
```



- 5 Type **X** then press **ENTER** to return to the ISDN Performance Monitoring Menu. Type **C** then press **ENTER** to display the PM Threshold/Alert Info screen.

```

17-OCT-98          PAIRGAIN TECHNOLOGIES INC., PG-FLEX TERMINAL          00:07:38
                   SYSTEM ID: List 3C - Tech Pubs                      SYSTEM: 1
                   PM THRESHOLD/ALERT INFO
-----
INTERIM PATH ENABLED  CARD:2  CHANNEL:1
-----
COT                CUSTOMER/NETWORK
Hourly ES          Hourly SES    Daily ES          Daily SES
Threshold Count    40                10                100               25
Threshold Exceeded no/no             no/no             no/no             no/no
Threshold Cross Alarm dis/dis         dis/dis         dis/dis         dis/dis

RT                CUSTOMER/NETWORK
Hourly ES          Hourly SES    Daily ES          Daily SES
Threshold Count    40                10                100               25
Threshold Exceeded no/no             no/no             no/no             no/no
Threshold Cross Alarm dis/dis         dis/dis         dis/dis         dis/dis

A) SELECT NEW CARD AND CHANNEL
B) CHANGE PM THRESHOLD COUNT
C) ENABLE/DISABLE THRESHOLD CROSSING ALARM

CTRL-X) Main Menu    e(X)it

[COT] ENTER COMMAND>

```

- 6 To select another card and channel: type **X** then press **ENTER** to return to the ISDN Performance Monitoring Menu. Otherwise, type **CTRL + X** to return to the Main Menu.

## Maintenance

On the Main Menu, press **C** then press **ENTER** to access the Maintenance Menu.

```

17-OCT-98          PAIRGAIN TECHNOLOGIES INC., PG-FLEX TERMINAL          04:01:22
                   SYSTEM ID: List 3C - Tech Pubs                      SYSTEM: 2

CURRENT STATUS: OK                                     LOGGED IN: COT
ALARMING TERMINAL: NONE

MAINTENANCE MENU
-----
A) METALLIC ACCESS
B) ISDN LOOPBACK

CTRL-X) Main Menu    e(X)it

[COT] ENTER COMMAND>

```

## Metallic Access

A metallic access connection to a subscriber circuit can be setup using the metallic access options.

- 1 On the Maintenance Menu, type **A** then press **ENTER** to display the Metallic Access Menu.

```

17-OCT-98          PAIRGAIN TECHNOLOGIES INC., PG-FLEX TERMINAL          04:01:10
                   SYSTEM ID: List 3C - Tech Pubs                      SYSTEM: 2

CURRENT STATUS: OK          LOGGED IN: COT
ALARMING TERMINAL: NONE

-----
METALLIC ACCESS MENU
-----
A) COT - BRIDGING
B) COT - LOOKING IN
C) COT - LOOKING OUT
D) RT - LOOKING OUT
E) RT - LOOKING IN
F) RT - BRIDGING
G) SUBSCRIBER BYPASS

R)remove access

CTRL-X) Main Menu      e(X)it

[COT] ENTER COMMAND>
    
```

Table 10 defines the functions of the metallic access menu parameter selections.

**Table 10. Metallic Access Menu Options**

Option	Parameter	Function
A	COT - Bridging	Monitors a subscriber circuit connection between the switch and the specified CO channel unit Tip/Ring pair.
B	COT - Looking In	The subscriber connection between the switch and the specified channel unit Tip/Ring pair can be tested. The channel under test is disconnected from the switch for this function. The technician will be able to verify connectivity between the channel under test and the CO switch.
C	COT - Looking Out	The subscriber connection through the CO channel unit toward the subscriber can be tested. The switch is disconnected from PG-Flex for this function.
D	RT - Looking In	Provides a connection to the subscriber circuit at the RT channel unit Tip/Ring pair with the subscriber terminal equipment disconnected. (Metallic bypass pair required.)
E	RT - Looking Out	Provides a connection to the subscriber drop with the RT channel unit disconnected. (Metallic bypass pair required.)
F	RT - Bridging	Monitors the connection between the RT channel unit and the subscriber terminal equipment. (Metallic bypass pair required.)
G	Subscriber Bypass	Provides a metallic connection from the switch to the subscriber's terminal equipment for the selected channel, bypassing the PG-Flex carrier transport. This is the only access connection that can be maintained after the technician logs off the craft port. (Metallic bypass pair required.)

- 2 On the Metallic Access Menu, type a letter (**A** through **G**) then press **ENTER** to display the Metallic Access menu and select the subscriber circuit to be accessed.

```

17-OCT-98      PAIRGAIN TECHNOLOGIES INC., PG-FLEX TERMINAL      22:58:46
                SYSTEM ID: List 3C - Tech Pubs                  SYSTEM: 2

CURRENT STATUS: OK                                LOGGED IN: COT
ALARMING TERMINAL: NONE

-----
METALLIC ACCESS MENU
-----

Press ESCAPE to return to previous menu

Enter Card and Channel (CARD,CHANNEL):

```

To select a subscriber circuit:

- 1 Type the card number followed by a comma. Then type the channel number for the ISDN circuit being configured, then press **ENTER** (for example, “1,2”) to select a subscriber circuit. Metallic access to the selected circuit is provided at the test jack on the FAU-728 Alarm Unit front panel. The Metallic Access Menu indicates the current metallic access configuration.
- 2 Use a volt/ohm meter or other test equipment to test the subscriber circuit.

```

17-OCT-98      PAIRGAIN TECHNOLOGIES INC., PG-FLEX TERMINAL      04:01:10
                SYSTEM ID: List 3C - Tech Pubs                  SYSTEM: 2

CURRENT STATUS: OK                                LOGGED IN: COT
ALARMING TERMINAL: NONE

-----
METALLIC ACCESS MENU
-----

A) COT - BRIDGING
B) COT - LOOKING IN
C) COT - LOOKING OUT
D) RT  - LOOKING OUT
E) RT  - LOOKING IN
F) RT  - BRIDGING
G) SUBSCRIBER BYPASS

R)remove access

CTRL-X) Main Menu    e(X)it

[COT] ENTER COMMAND>

```

To release a subscriber drop, select **R** then press **ENTER**.

## ISDN Loopback Menu

On the Maintenance Menu, type **B** then press **ENTER** to display the ISDN Loopback Menu.

```

17-OCT-98          PAIRGAIN TECHNOLOGIES INC., PG-FLEX TERMINAL          04:01:16
                   SYSTEM ID: List 3C - Tech Pubs                      SYSTEM: 2
                   ISDN LOOPBACK MENU
-----
COT LOOPBACK MAP   CARD:1
-----
LOOPBACK           CH1           CH2           CH3           CH4
-----
B1 DSL             normal          normal          normal          normal
B2 DSL             normal          normal          normal          normal
2B+D DSL           normal          normal          normal          normal
B1 DC              normal          normal          normal          normal
B2 DC              normal          normal          normal          normal
2B+D DC            normal          normal          normal          normal

                P)revious Card or N)ext Card
                S)witch between COT or RT Loopback
                C)hange Loopback Mode

                CTRL-X) Main Menu  e(X)it

[COT] ENTER COMMAND>

```

To initiate a loop back on an ISDN line:

- 1 On the ISDN Loopback menu, type **C** and press **ENTER**.
- 2 Type the card number followed by a comma. Then type the channel number for the ISDN circuit being configured, then press **ENTER** (for example, "1,2").
- 3 Select the Loopback type desired. In most instances, a loopback of the B1 or B2 channels towards the office (DSL) or customer (DC) is sufficient to verify operation of the ISDN circuit.

To release Loopback on an ISDN line:

- 1 On the ISDN Loopback menu, type **C** and press **ENTER**.
- 2 Type the card number followed by a comma. Then type the channel number for the ISDN circuit being configured, then press **ENTER** (for example, "1,2").
- 3 Select Set Normal from the loopback mode menu.
- 4 Type **CTRL + X** to return to the Main Menu.

## Display System Inventory

This option allows displaying of manufacturing and version information for all the units in the system (except the FAU/FPI unit).

On the Main Menu, type **D** then press **ENTER** to display the system Inventory screen.

```

17-OCT-98          PAIRGAIN TECHNOLOGIES INC., PG-FLEX TERMINAL          11:20:02
                   SYSTEM ID: List 3C - Tech Pubs SYSTEM: 1

INVENTORY
-----
LOC  SLOT   MODEL  LIST  ISSUE  TYPE      S/W   P1 TAG  CLEI CODE
-----
COT  LU1    FLL-716  3C    1      32-CH E1*  4.7   2658001749
COT  CU1    FLC-703   4     1      POTG8     1.3   2057000141  VACHCHGCAA
COT  CU2    FLC-703   3     1      POTG8     1.3   0217001889  VACHCDGCAA
COT  CU3    FLC-703   3     1      POTG8     1.3   0217001722  VACHCDGCAA
COT  CU4    FLC-706   1     1      ISDN4     1.4   0148002670  VACHEGJCAA
RT   LU    FRL-746  3C    1      32-CH E1*  4.7   3108001710
RT   CU1    FRC-753   4     1      POTG8     1.5   0838004040  VARHCKGCAA
RT   CU2    FRC-753   2     1      POTG8     1.4   2067001665  VARHCKGCAA
RT   CU3    FRC-753   2     1      POTG8     1.4   3486001316  VARHCKGCAA
RT   CU4    FRC-756   1     1      ISDN4     1.3   1747001417  VARHEJCAA

                   CTRL-X) Main Menu      e(X)it

[COT] ENTER COMMAND>
    
```

**Table 11. Inventory Menu Definitions**

Parameter	Definition
LOC	Card location (the COT shelf or the RT enclosure)
SLOT	Slot location
MODEL	Card model
LIST	Card list number
ISSUE	Issue number
TYPE	Type (E1, T1, POTS, ISDN)
S/W	The software version of the installed card
P1 TAG	An ASCII character string up to 10 characters representing the manufacturing serial number
CLEI CODE	Card CLEI code

Type **CTRL + X** to return to the Main Menu.

# TROUBLESHOOTING

Table 12 provides troubleshooting procedures based on indications displayed by the front panel indicators of FLL-716.

**Table 12.** FLL-716 COT Line Unit Troubleshooting

Indication	Problem	Action
POWER LED off	<ul style="list-style-type: none"> <li>The COT Shelf is not receiving CO battery.</li> </ul>	<ol style="list-style-type: none"> <li>Verify that the shelf fuse on the equipment bay is good.</li> <li>Verify wiring between the COT shelf and the CO fuse panel, and from the panel to the CO battery.</li> </ol>
	<ul style="list-style-type: none"> <li>The CO line unit fuse F1 has blown.</li> </ul>	<ol style="list-style-type: none"> <li>Replace the fuse in the CO line unit with a 3A GMT type.</li> </ol>
LOOP 1 (2) SYNC LED flashing or off	<ul style="list-style-type: none"> <li>The HDSL line is attempting to synchronize with the remote terminal line unit or cannot detect the HDSL signal from the remote terminal line unit. This is usually an indication that there is a problem with the HDSL circuit between the COT and RT (assuming the FAULT LED is off).</li> </ul>	<ol style="list-style-type: none"> <li>Verify the HDSL circuits are terminated properly and with the correct orientation.</li> <li>Measure the loop resistance of each HDSL circuit (shorting the pair at the far end). The loop resistance must be less than that shown in Table 2.</li> </ol>
	<ul style="list-style-type: none"> <li>The COLU and RTLU are incompatible. That is, one is a T1 version and the other is an E1 version</li> </ul>	<ol style="list-style-type: none"> <li>Replace the incompatible line unit.</li> </ol>
LOOP 1 (2) MARGIN LED on	<ul style="list-style-type: none"> <li>The HDSL line margin level is below the preset level.</li> </ul>	<ol style="list-style-type: none"> <li>Check the preset Margin Alarm level in the Setup Menu.</li> <li>Measure the loop resistance of each HDSL circuit (shorting the pair at the far end). The loop resistance must be less than that shown in Table 2.</li> </ol>
FAULT LED on	<ul style="list-style-type: none"> <li>Faulty FLL-716 CO line unit</li> </ul>	<ol style="list-style-type: none"> <li>Check that none of the HDSL pairs are shorted to ground.</li> <li>Check for continuity from COT to RT on all HDSL lines.</li> <li>Replace the COT line unit, if the RT line unit is confirmed good. Otherwise, replace the RT line unit.</li> </ol>

# PRODUCT SUPPORT

## TECHNICAL SUPPORT

Technical Assistance is available 24 hours a day, 7 days a week by the contacting Customer Service Engineering group at:

Telephone: 800.366.3891  
The 800 telephone support line is toll-free in the U.S. and Canada.

Email: [wsd\\_support@adc.com](mailto:wsd_support@adc.com)

Knowledge Base: [http://adc.com/Knowledge\\_Base/index.jsp](http://adc.com/Knowledge_Base/index.jsp)

Web: [www.adc.com](http://www.adc.com)

## LIMITED WARRANTY

Product warranty is determined by your service agreement. Refer to the ADC Warranty/Software Handbook for additional information, or contact your sales representative or Customer Service for details.

## RETURNS

To return equipment to ADC:

- 1 Locate the number of the purchase order under which the equipment was purchased. To obtain a return authorization number, you need to provide the original purchase order number to ADC's Return Material Authorization (RMA) Department.
- 2 Call or write ADC's RMA Department to ask for an RMA number and any additional instructions. Use the telephone number, fax number or email address listed below:
  - Telephone: 800.366.3891
  - Email Address: [rma@ADC.com](mailto:rma@ADC.com)
- 3 Include the following information, in writing, along with the equipment you are returning:
  - Company name and address.
  - Contact name and telephone number.
  - The shipping address to which ADC should return the repaired equipment.
  - The original purchase order number.
  - A description of the equipment that includes the model and part number of each unit being returned, as well as the number of units that you are returning.
  - The reason for the return. For example:
    - The equipment needs an ECO/ECN upgrade.
    - The equipment is defective.



**If the equipment is defective, please tell us what you observed just before the equipment malfunctioned. Be as detailed in your description as possible.**

If there is another reason for returning the equipment, please let us know so we can determine how best to help you.

- 4 Pack the equipment in a shipping carton.
- 5 Write ADC's address and the RMA Number you received from the RMA Department clearly on the outside of the carton and return to:

ADC DSL Systems, Inc.  
14352 Franklin Ave.  
Tustin, CA 92780-7013

Attention: **RMA (Number)**



**All shipments are to be returned prepaid. ADC will not accept any collect shipments.**



## **FCC CLASS A COMPLIANCE**

This equipment has been tested and found to comply with the limits for a Class A digital device, pursuant to Part 15 of the FCC rules. These limits are designed to provide reasonable protection against harmful interference when the equipment is operated in a commercial environment. This equipment generates, uses and can radiate radio frequency energy and, if not installed and used in accordance with the instruction manual, may cause harmful interference to radio communications. Operation of this equipment in a residential area is likely to cause harmful interference in which case the user will be required to correct the interference at his own expense.

## **Modifications**

The FCC requires the user to be notified that any changes or modifications made to this device that are not expressly approved by ADC Technologies, Inc. voids the user's warranty.

All wiring external to the product(s) should follow the provisions of the current edition of the National Electrical Code.

# ACRONYMS

<b>CO</b>	Central Office
<b>COLU</b>	Central Office Line Unit
<b>COT</b>	Central Office Terminal
<b>CRC</b>	Cyclic Redundancy Check
<b>DCE</b>	Data Communications Equipment
<b>DIP</b>	Dual In-Line Package
<b>DSL</b>	Digital Subscriber Line
<b>ES</b>	Errored Seconds
<b>DTR</b>	Data Terminal Ready
<b>HDSL</b>	High-bit-rate Digital Subscriber Line
<b>ISDN</b>	Integrated Services Digital Network
<b>LED</b>	Light Emitting Diode
<b>LU</b>	Line Unit
<b>NVRAM</b>	Non Volatile Random Access Memory
<b>PCM</b>	Pulse Code Modulation
<b>PM</b>	Performance Monitoring
<b>POTS</b>	Plain Old Telephone Service
<b>REN</b>	Ringer Equivalency Number
<b>RMA</b>	Return Material Authorization
<b>RT</b>	Remote Terminal

# GLOSSARY

<b>Margin</b>	The excess signal to noise ratio, at either the COT or RT, relative to a $10^{-7}$ Bit Error Rate. <i>cr</i> is the current margin, <i>mn</i> is the minimum margin since last cleared, <i>mx</i> is the maximum value since cleared, and N/A means Not Available. The normal range of a typical margin is from 22 to 6 dB.
<b>Pulse Attenuation</b>	The attenuation of the 2B1Q pulse from the distant end. This value is related to the cable pair's 196-kHz loss. The pulse attenuation is a more direct indication of the loop attenuation to the 2B1Q signal than the 196-kHz loss. The normal range of pulse attenuation is from 1 to 32 dB.
<b>PPM</b>	The relative offset of the crystal oscillator in the RT line unit from the COT line unit's crystal oscillator. Any value between -64 and +64 is adequate. Values outside this range indicate out of tolerance components or excessive temperature drift of critical components.
<b>HDSL 24 Hour ES</b>	The number of 1-second intervals that contained at least one CRC error. This value is a running total of errored seconds (ES) for the last 24 hours.
<b>HDSL 24 Hour UAS</b>	The number of (unavailable) seconds the HDSL loop was out of synchronization.



---

**World Headquarters:**

ADC Telecommunications, Inc.  
12501 Whitewater Drive  
Minnetonka, Minnesota USA 55343

**For Technical Assistance:**

800.366.3891



1251762

---