

## Technical Assistance

PairGain Technical Assistance is available 24 hours per day, 7 days per week by contacting PairGain's Customer Service Engineering group (listed below).

During normal business hours (8:00 AM to 5:00 PM, Pacific Time, Monday through Friday, excluding holidays), technical assistance calls are normally answered directly by a Customer Service Engineer. At other times, a request for technical assistance is handled by an on-duty Customer Service Engineer through a callback process. This process normally results in a return call within 30 minutes of initiating the request.

In addition, PairGain maintains a computer bulletin board system for obtaining current information on PairGain products, product fault isolation tips and aids, helpful utilities, and for posting requests or questions. This system is available 24 hours per day by calling (714) 730-2800. Transmission speeds up to 28.8 kbps are supported with a character format of 8-N-1.

PairGain product, company, and application information can be found at <http://www.pairgain.com> using any Web browser.

## Limited Warranty

PairGain Technologies, Inc. warrants this product to be free of defective and faulty workmanship for a period of 60 months, under normal use, from the date of shipment. PairGain's obligation under this warranty is limited to replacing or repairing, at PairGain's option, any such product that is returned during the warranty period per PairGain's instructions and which product, in PairGain's sole option, is determined to be defective upon examination at our plant.

Do not try to repair or disassemble the unit. If it fails, replace it with another unit and return the faulty unit to PairGain for repair. Any modifications of the unit by anyone other than an authorized PairGain representative will void the warranty.

If a unit needs repair, call PairGain at (800) 638-0031 for a Return Material Authorization (RMA) number and return the defective unit, freight prepaid, along with a brief description of the problem, to the PairGain Technologies, Inc. at 14352 Franklin Avenue, Tustin, CA 92780-7013.

PairGain will continue to repair or replace faulty modules beyond the warranty program at a nominal charge. Contact your PairGain sales representative for details and pricing.

## FCC Compliance

This unit complies with the limits for Class A digital devices pursuant to Part 15 of the FCC rules. These limits are designed to provide reasonable protection against harmful interference when the equipment is operated in a commercial environment. This equipment generates, uses, and can radiate radio frequency energy and, if not installed and used in accordance with the instruction manual, can cause harmful interference to radio communications. Operation of this equipment in a residential area is likely to cause harmful interference, in which case the user will be required to correct the interference at his own expense.

Refer to the installation section of the appropriate instruction manual for the unit you are installing to get information on cabling, correct connections, and grounding.

**Corporate Office:**  
14402 Franklin Avenue  
Tustin, CA 92780  
Tel: (714) 832-9922  
FAX: (714) 832-9924

**For Technical Assistance:**  
(800) 638-0031



Copyright © 1998 PairGain Technologies Inc.

# PAIRGAIN

Section Number 363-796-104-01, Revision 01, June 24, 1998

# PG-FLEX FPI STREAKER CARD QUICK INSTALLATION GUIDE

## MODEL FSU-796 LIST 4, P/N 150-1396-04

This PairGain® PG-Flex™ FSU-796 List 4 FPI Streaker card is a continuity tester. The card verifies that the PGTC interface and Alarm connections from the "MAINT UNIT" slot of a PG-Flex Central Office Terminal (COT) shelf (19" or 23") are wired correctly to the Central Office (CO) Main Distribution Frame (MDF).

## Unpack and Inspect the Shipment

When you receive the PG-Flex FSU-796 List 4 streaker card:

- 1 Unpack the PG-Flex FSU-796 streaker card and visually inspect it for signs of damage. If the components have been damaged in transit, immediately report the extent of damage to the transportation company and to your sales representative. Order a replacement unit if necessary.
- 2 Compare the contents of the package against the packing list. If the shipment is incorrect, contact PairGain as described in the "Limited Warranty" section.

## Features of the FSU-796 List 4

The illustration shows the FSU-796 List 4 front panel, and the table below describes the features and functions for the front panel LEDs and the LED Test switch.

Feature	Function
<b>PGTC Interface Status LEDs</b>	
TIP 1 - 4	These 28 LEDs are used to verify the PGTC Interface connections.
RING 1 - 4	
LOCK 1-4	The appropriate LED lights when one of the 28 PGTC Interface terminations from the MDF is shorted to ground.
SLEEVE 1 - 4	
ON-HOOK 1 - 4	If the LED for the termination under test does not light, or the wrong LED lights, the termination is miswired.
PROCEED 1 - 4	
TSTALM	
TMAJ	
SEIZE	
SEZBY	
<b>Alarm Status LEDs</b>	
SHELF ID	These 15 LEDs are used to verify major and minor visual and audible alarms.
MAJ AUD	The appropriate LED lights when one of the Alarm terminations from the MDF is shorted to ground.
MAJ VIS	If the LED for the termination under test does not light, or the wrong LED lights, the termination is miswired.
MIN AUD	
MIN VIS	For the relay contact, NO is normally open, C is common, and NC is normally closed.
-48 CO LED	Indicates that the CO battery is wired correctly.
LED Test Switch	When pressed, lights all LEDs on the Streaker card.

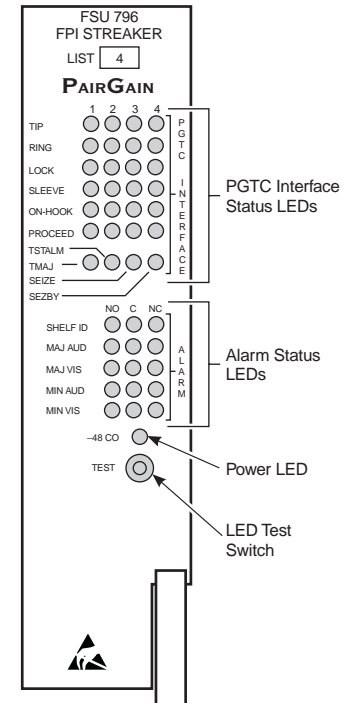

## Installing and Testing the FSU-796 List 4



The COT shelf power must be connected to provide -48V to the FSU-796.

- Slide the FSU-796 List 4 into the COT shelf "MAINT UNIT" slot (see the illustration below) until the retaining latch on the front panel locks into position.
- Verify that the -48 CO LED is on. If the -48 CO LED is not on:
  - verify that frame ground and CO battery are connected (refer to local practices).
  - verify that the fuses are installed in the equipment bay fuse panel.
  - replace the FSU-796 streaker card.
- Press the LED Test switch and verify that all PGTC interface and alarm LEDs are on. Replace the FSU-796 if any of the LEDs do not light.

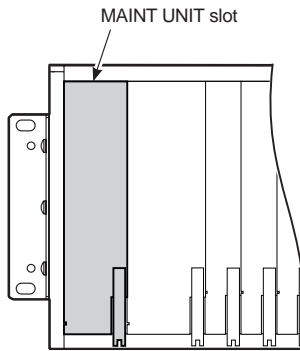

PG-Flex FSU-796 List 4 Slot Location

## Testing the MAINT UNIT Slot Wiring

- From the MDF, connect a jumper lead from frame ground to the appropriate PGTC or alarm connector termination on the MDF (refer to Table 1 and Table 2 for PGTC and alarm connector pinouts). Verify that the corresponding PGTC interface or alarm status LED on the FSU-796 is on.
  - If the correct PGTC interface or alarm LED lights, proceed to the next connector termination.
  - If the PGTC interface or alarm LED under test does not light, or if the wrong LED lights, check the wiring to the COT shelf.
- Repeat the previous step for each PGTC interface and alarm LED connector termination.

Table 1. PGTC Interface Connector Pinouts

Pin	Signal	Pin	Signal
1	PGTC_RING1	26	PGTC_TIP1
2	PGTC_RING2	27	PGTC_TIP2
3	PGTC_RING3	28	PGTC_TIP3
4	PGTC_RING4	29	PGTC_TIP4
5	SLEEVE2	30	SLEEVE1
6	SLEEVE4	31	SLEEVE3
7	OH2	32	OH1
8	OH4	33	OH3
9	PROCEED2	34	PROCEED1
10	PROCEED4	35	PROCEED3
11	LOCK2	36	LOCK1
12	LOCK4	37	LOCK3
17	TMAJ	42	TSTALM
22	SEZBY	47	SEIZE

Table 2. Alarm Wire-Wrap Terminations

Relay	NO*	COM*	NC*
SHELF_ID	1	2	3
MAJ_AUD	4	5	6
MAJ_VIS	7	8	9
MIN_AUD	10	11	12
MIN_VIS	13	14	15

\* For the relay contacts, NO is normally opened, NC is normally closed, and COM is common.