PG-FLEX 8 CHANNEL RT POTS UNIT MODEL FRC-754

Model	List Number	Part Number	CLEI Code
FRC-754	1	150-1354-01	N/A



PAIRGAIN TECHNOLOGIES, INC.
ENGINEERING PLANT SERIES TECHNICAL PRACTICE
SECTION 363-754-100-02

Revision History of this practice.
Revision 02—January 12, 1998
A) Update Format

TABLE OF CONTENTS

A. PRODUCT OVERVIEW	1
1. Description and Features.....	1
2. Front Panel	2
3. Specifications	3
B. FUNCTIONAL DESCRIPTION.....	4
4. Applications	4
5. Operational Capabilities	6
C. INSTALLATION AND TEST.....	7
6. Unpacking	7
7. Turn-Up and Testing.....	7
8. Troubleshooting.....	7
D. TECHNICAL SUPPORT.....	9
9. Technical Support.....	9
E. CERTIFICATION AND WARRANTY.....	9
10. Certification.....	9
11. Warranty.....	10
F. ABBREVIATIONS	10
12. Abbreviations	10

USING THIS TECHNICAL PRACTICE

Two types of messages, identified by icons, appear in the text:



A note informs you of special circumstances.



Cautions indicate the possibility of damage to equipment or the possibility of personal injury.

©Copyright 1998 PairGain Technologies, Inc.

PairGain is a registered trademark, and PG-Flex is a trademark of PairGain Technologies, Inc.

Information contained in this document is Company Private to PairGain Technologies and shall not be modified, used, copied, reproduced, or disclosed in whole or in part without the written consent of PairGain.

Other product names mentioned in this practice are used for identification purposes only and may be trademarks and/or registered trademarks of their respective companies.

A. PRODUCT OVERVIEW

1. Description and Features

- 1.1** The PairGain® PG-Flex™ FRC-754 List 1 Channel Unit provides eight POTS interfaces between a PG-Flex Remote Terminal (RT) and subscribers. The FRC-754 Channel Unit uses A-Law pulse code modulation (PCM) encoding. The FRC-754 Channel Unit includes green status LEDs for each line indicating idle, ringing, and off-hook conditions, as well as a red LED indicating a fault condition on the Channel Unit. The channel unit provides metallic test access to the subscriber line connection through an optional metallic bypass pair.
- 1.2** Features of the PG-Flex FRC-754 COT Channel Unit:
- eight POTS subscriber interfaces
 - 64 kbps A-Law PCM encoding
 - metering tones (12 kHz, 16 kHz)
 - front panel ACTIVE LEDs indicate idle, ringing, metallic test access, and off-hook for each channel
 - front panel FAULT LED indicator simplifies troubleshooting

2. Front Panel

2.1 **Figure 1 shows the FRC-754 front panel.** Table 1 lists the different states and indications for the FRC-754 Channel Unit front panel LEDs.

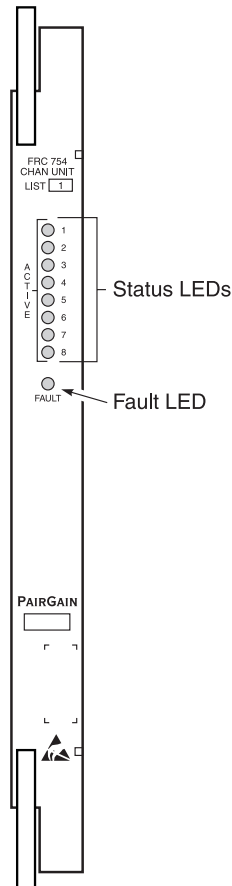

Figure 1. FRC-754 Front Panel

Table 1. FRC-754 Front Panel LEDs

LED	LED State	Indicates
ACTIVE (1 through 8)	Solid green	Channel is off hook.
	Fast flashing green	Channel is in test access mode.
	Slow flashing green	Channel is ringing.
FAULT	Off	Channel is on hook.
	Red	Fault detected by the unit. See Table 3 for troubleshooting procedures.
	Off	No faults detected.

3. Specifications

Electrical Characteristics

Analog Impedance	600 ohms
DC Loop Current	> 20 mA into off-hook dc resistance
Ringer Output Drive.....	15 REN maximum per RT, 5 REN maximum per channel
RT DC Supervisory Range	960 ohms. Maximum cable resistance, minus 430 ohms for handset, is 530 ohms
RT Idle State Loop Voltage (On-Hook).....	> 40 Vdc. Ring is negative with respect to Tip
RT Loop Closure (Off-Hook) Detection	< 960 ohms between Tip and Ring
RT On-Hook Detection	> 10 kohms

Environmental

Operating Elevation	-200 ft. to 13,000 ft (-60 m to 4,000 m)
Temperature and Humidity	-40° F to +150° F (-40° C to +65° C) 5% to 95% (non condensing)

Physical

Weight	0.6 lb. (0.3 kg)
Dimensions	
Height	12.00 in. (30.5 cm)
Width	1.00 in. (2.5 cm)
Depth	4.50 in. (11.4 cm)

B. FUNCTIONAL DESCRIPTION

4. Applications

4.1 PG-Flex is a small capacity universal subscriber carrier system that can support up to 32 subscriber channels, including POTS and ISDN services. The system, based on HDSL transmission technology, is remotely powered from the Central Office. Using two 24 gauge (0.5 mm) unconditioned copper pairs, the remote terminal may be located up to 10.7 kft (3.3 km) from the Central Office terminal. Standard 19- or 23-inch shelves contain multiple systems; circuit cards may be hot-swapped without affecting other systems installed in the shelf. POTS channel units use 64-kbps A-Law pulse coded modulation (PCM) encoding to allow Group 3 facsimile or high-speed modem operation on all channels.

4.2 System Flex Configuration. Figure 2 shows a typical PG-Flex system that consists of:

- **COT.** Two complete systems may be installed in a 19-inch COT Shelf and four complete systems may be installed in a 23-inch COT Shelf. Each system requires one COT Line Unit and up to three (23-inch shelf) or six (19-inch shelf) Channel Units. A common Alarm Unit or Pair Gain Test Controller Interface Unit in each shelf provides an interface for maintenance alarm relays and metallic access to the remote subscriber lines.
- **RT.** The Remote Terminal communicates with, and is line-powered from, the COT over two pairs of 19- to 26-gauge (0.9 mm to 0.4 mm) twisted-pair telephone wire. Each pair carries both power and HDSL signaling. The RT Enclosure provides a weatherproof housing for the PG-Flex remote electronics and subscriber terminations. The enclosure accepts one common RT Line Unit and up to four Channel Units.

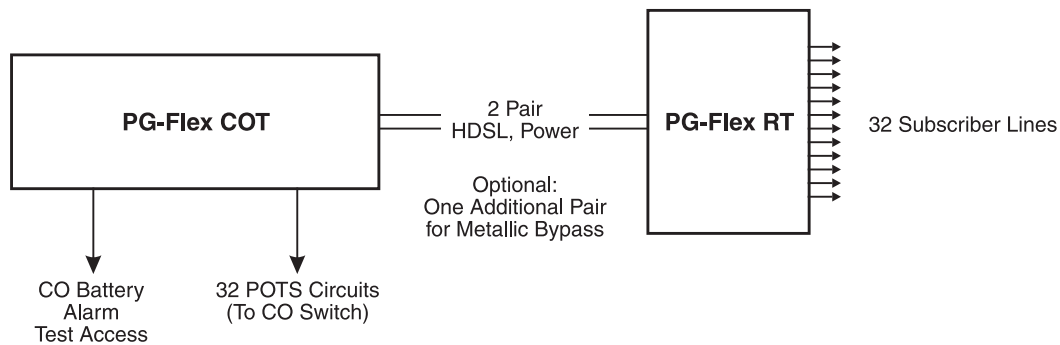

Figure 2. Typical PG-Flex Configuration

- 4.3 HDSL Transmission.** PG-Flex utilizes HDSL transmission technology between the COT and RT and provides up to 32 DS0s, plus signaling, over two copper pairs without the need for repeaters, loop conditioning, or pair selection. Adaptive equalization, scrambling, and a four-level 2B1Q line coding scheme increase range and minimize crosstalk.
- 4.4** The line interface is a two-pair, 1110-kbps full-duplex 2B1Q transmission format. The dual HDSL lines provide thirty-two 64-kbps channels with signaling, and an embedded operations channel for management control. The signal characteristics on the carrier pairs comply with TR-NWT-001210, *Generic Requirements for High-bit-rate Digital Subscriber Line (HDSL) Systems*.
- 4.5** For the system configuration depicted in Figure 2, the maximum distance between the COT and the RT is 10.7 kft (3.3 km), assuming the HDSL lines are 24 gauge (0.5 mm). Table 2 shows the maximum distance between the COT and RT for various gauge wire. Due to the nature of HDSL transmission technology, the HDSL lines do not require any special conditioning and may include unterminated bridge taps, but cannot include load coils.

Table 2. PG-Flex Distances

Wire Gauge	Loop Length		
	16/32 Channel System		Resistance @ 28 °C
26 AWG (0.4 mm)	8.1 kft	(2.5 km)	686 Ω
24 AWG (0.5 mm)	10.7 kft	(3.3 km)	569 Ω
22 AWG (0.6 mm)	13.7 kft	(4.2 km)	457 Ω
19 AWG (0.9 mm)	19.4 kft	(5.9 km)	322 Ω

- 4.6 Subscriber Drop Testing.** For subscriber drop testing from the CO, PG-Flex is able to select and connect any subscriber drop to a metallic test pair at the RT. PG-Flex extends this connection back to the COT where technicians can switch it onto a test access bus, or to the corresponding subscriber line on the COT channel card.
- Metallic access is performed from the subscriber's COT. Refer to the FLC-704 technical practice for more information.

5. Operational Capabilities

5.1 The FRC-754 RT Channel Unit provides 8 POTS interfaces between the RT and subscribers, and performs the following functions:

- 64 kbps A-Law PCM encoding
- applies ringing voltage
- generates forward disconnect
- generates metering tones
- detects an off-hook or ring-trip condition
- connects a subscriber loop to a metallic test pair
- protects against secondary surges

5.2 A block diagram of the FRC-754 Channel Unit is shown in Figure 3. One 8-Channel RT Channel Unit supports eight POTS interfaces.

5.3 A status LED is associated with each line to indicate whether the line is off-hook, idle, ringing, or being tested. A common fault LED indicates a general fault has been detected on the card and it should be replaced.

5.4 Test access connections to a specific line circuit are made through the maintenance terminal or by the CO switch applying the appropriate voltages on the subscriber line (see paragraph 4.6).

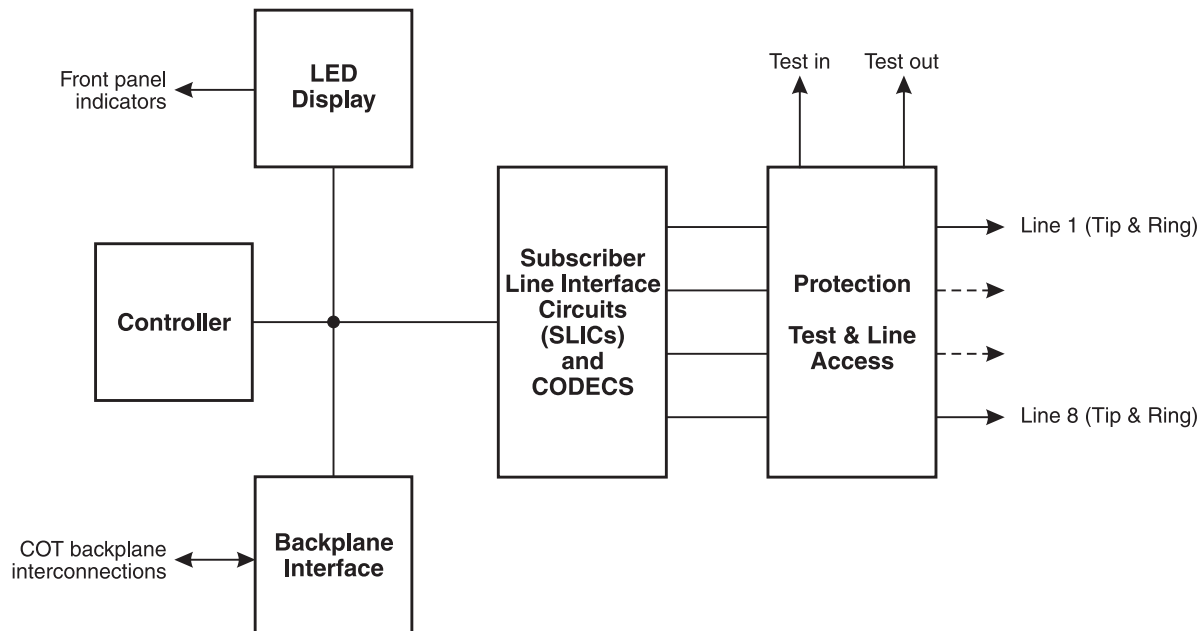

Figure 3. FRC-754 Block Diagram

C. INSTALLATION AND TEST

6. Unpacking

6.1 Upon receipt of the equipment, proceed as follows:

- 1 Unpack each container and visually inspect it for signs of damage. If the equipment has been damaged in transit, immediately report the extent of damage to the transportation company and to PairGain. Order replacement equipment if necessary.
- 2 Check the contents versus the packing list to ensure complete and accurate shipment. If the shipment is short or irregular, contact PairGain as described in Section 9. If you must store the equipment for a prolonged period, store the equipment in its original container.

7. Turn-Up and Testing



Observe normal electrostatic discharge precautions when handling electronic equipment. Do not hold electronic plugs by their connector edges. Do not touch components or circuitry.

7.1 Install RT Channel Units

- 1 Insert each FRC-754 Channel Unit into the FRE-765 RT enclosure.

All LEDs on the Channel Unit will turn on for approximately 2 seconds, then scan from top to bottom, then flash all on, then off.

- 2 After the system has powered up, established HDSL synchronized communications, and no calls are in progress, verify that the Channel Unit front panel indicators ACTIVE 1 through ACTIVE 8 and FAULT LEDs are all off.

7.2 **Test Subscriber Circuits.** Test each subscriber circuit by placing and receiving calls; ACTIVE 1 through 8 LEDs track call progress.



To reduce the power required by the Remote Terminal, the RT Channel Unit LEDs will extinguish after a two minute time-out. Press and hold the ACO button on the RT Line Unit for two seconds to reactivate the LEDs for another two minutes.

8. Troubleshooting

8.1 Table 3 on page 8 provides troubleshooting procedures based on indications displayed by the front panel indicators of FRC-754 Channel Unit.

Table 3. FRC-754 Channel Unit Troubleshooting

Indication	Problem	Action
FAULT LED ON	The FRC-754 processor has detected a fault.	Remove and reinsert the Channel Unit. If the FAULT LED does not extinguish, replace the Channel Unit.
Troubleshooting based on customer-originated trouble reports		
No Dial tone, Can't Dial	<ul style="list-style-type: none"> • faulty RT or COT Channel Unit • facility short/open • CO switch problem 	<ol style="list-style-type: none"> 1 Lift the subscriber pair at the network interface. If dial tone is present and you can place a call, refer the problem to the customer per local practice. 2 If you cannot hear dial tone or cannot place a call at the network interface (with the subscriber pair lifted), check for dial tone at the RT. If dial tone is present, check the pair between the RT and the network interface. If no dial tone is present, replace the RT Channel Unit. 3 If the problem still exists, reinsert the original RT Channel Unit and replace the COT Channel Unit. Test for operation. 4 If the problem still exists, refer the problem to the CO switch.
Phone Doesn't Ring	<ul style="list-style-type: none"> • high-resistance subscriber line short • faulty RT or CO Channel Unit • loop length too long 	<ol style="list-style-type: none"> 1 Lift the subscriber pair at the network interface. If ringing is present, refer the problem to the customer per local practice. 2 If ringing is not present, check for ringing at the RT. If ringing is present, check the pair between the RT and the network interface. If no ringing is present, replace the RT Channel Unit. If ringing is still not present, check a circuit on another Channel Unit. If ringing is still not present, replace the RT Line Unit. 3 If ringing is still not present at the RT, reinsert the original Channel Unit and Line Unit. Test for ringing at the COT. 4 Test for ringing into the COT from the CO switch. If no ringing is present, refer the trouble to the CO switch. If ringing is present, replace the COT Channel Unit. Test again for ringing at the network interface. If ringing is still not present, contact PairGain technical assistance per section 9. 5 Verify the resistance of the copper loop between the RT Enclosure and the network interface is less than 530 Ω.
Phone doesn't stop ringing	<ul style="list-style-type: none"> • faulty subscriber instrument • faulty RT Channel Unit • loop length too long 	<ol style="list-style-type: none"> 1 Test for ring trip at the network interface. If the ringing is tripped, refer the trouble to the customer per local practice. 2 If the ringing is not tripped, test for tripping at the RT. If ring trip does occur, check the loop for excessive length. If ring trip does not occur, replace the RT Channel Unit. If ring trip still does not occur, contact PairGain technical assistance per section 9. 3 Verify the resistance of the copper loop between the RT Enclosure and the network interface is less than 530 Ω.
Can't Hear, Can't Be Heard	<ul style="list-style-type: none"> • subscriber problem • faulty RT or COT Channel Unit 	<ol style="list-style-type: none"> 1 Lift the subscriber line at the network interface and check the signal level. If correct, refer trouble to the customer per local practice. 2 If the level is too low, check the level at the RT. If the level is correct at the RT, check the pair between the RT and the network interface. If the level is too low at the RT, replace the RT Channel Unit. 3 If the level is still too low, reinsert the original RT Channel Unit. 4 Check the level at the COT coming from the CO switch. If it is correct, replace the COT Channel Unit. If it is not correct, refer the problem to the CO regarding the switch. 5 If the level is still not correct, reinsert the original COT Channel Unit. Contact PairGain technical assistance per section 9.

D. TECHNICAL SUPPORT

9. Technical Support

- 9.1** PairGain Technical Assistance is available 24-hours-a-day, 7-days-a-week by contacting PairGain Customer Service Engineering group at:
- Telephone:** (800) 638-0031 or (714) 832-9922
- Fax:** (714) 832-9924
- 9.2** During normal business hours (8:00 AM to 5:00 PM, Pacific Time, Monday - Friday, excluding holidays), technical assistance calls are normally answered directly by a Customer Service Engineer. At other times, a request for technical assistance is handled by an on-duty Customer Service Engineer through a callback process. This process normally results in a callback within 30 minutes of initiating the request.
- 9.3** In addition, PairGain maintains a computer bulletin board system for obtaining current information on PairGain products, product troubleshooting tips and aids, accessing helpful utilities, and for posting requests or questions. This system is available 24-hours-a-day by calling (714) 730-3299. Transmission speeds up to 28.8 kbps are supported with a character format of 8-N-1.

E. CERTIFICATION AND WARRANTY

10. Certification

- 10.1** **FCC Compliance.** The FRC-754 List 1 Channel Unit complies with the limits for Class A digital devices pursuant to Part 15 of the FCC rules. These limits are designed to provide reasonable protection against harmful interference when the equipment is operated in a commercial environment. This equipment generates, uses and can radiate radio frequency energy and, if not installed and used in accordance with the instruction manual, may cause harmful interference to radio communications. Operation of this equipment in a residential area is likely to cause harmful interference in which case the user will be required to correct the interference at his own expense.
- 10.2** Refer to the installation section of the appropriate instruction manual for the unit you are installing to get information on:
- cabling
 - proper connections
 - grounding
 - line power
- 10.3** All wiring external to the product(s) should follow the provisions of the current edition of the National Electrical Code.

11. Warranty

- 11.1** PairGain Technologies warrants this product to be free of defects and to be fully functional for a period of 5 years from the date of original shipment, given proper customer installation and regular maintenance. PairGain will repair or replace any unit without cost during this period if the unit is found to be defective for any reason other than abuse or improper use or installation.
- 11.2** This module should not be field repaired. If it fails, replace it with another unit and return the faulty unit to PairGain for repair. Any modifications of the unit by anyone other than an authorized PairGain representative will void the warranty.
- 11.3** If a unit needs repair, call PairGain for a Return Material Authorization (RMA) number and return the defective unit, freight prepaid, along with a brief description of the problem, to:
- PairGain Repair Center
14352 Franklin Avenue
Tustin, CA 92780-7013
- FAX: (714) 730-2961
Phone: (714) 730-2800 or (800) 370-7670
- 11.4** PairGain will continue to repair faulty modules beyond the warranty program at a nominal charge. Contact your PairGain sales representative for details and pricing.

F. ABBREVIATIONS

12. Abbreviations

2B1Q	2 binary bits encoded in one quaternary symbol
CLASS	Custom Local Area Signaling Services
CO	Central Office
COT	Central Office Terminal
DS0	Digital Signal Level Zero (64 kb/s)
DTMF	Dual Tone Multi-Frequency
MLT	Mechanized Loop Testing
PBX	Private Branch Exchange
PCM	Pulse Code Modulation
PGTC	Pair Gain Test Controller
POTS	Plain Old Telephone Service
RMA	Return Material Authorization
RT	Remote Terminal

Corporate Office
14402 Franklin Avenue
Tustin, CA 92780

Tel: (714) 832-9922
Fax: (714) 832-9924

