PG-FLEX EIGHT CHANNEL REMOTE TERMINAL LOOP START/GROUND START UNIT

Model	List Number	Part Number	CLEI Code
FRC-753	4	150-1353-04	VARHCKGCAA



PAIRGAIN TECHNOLOGIES, INC.
ENGINEERING PLANT SERIES TECHNICAL PRACTICE
SECTION 363-753-104-01

Revision History of this practice.
Revision 01—June 4, 1997
A) Initial Release.

TABLE OF CONTENTS

A. PRODUCT OVERVIEW	1
1. Description and Features.....	1
2. Front Panel	2
3. Specifications	3
B. FUNCTIONAL DESCRIPTION.....	3
4. Applications	3
5. Operational Capabilities	4
C. INSTALLATION AND TEST.....	5
6. Unpacking	5
7. Installation.....	5
8. Troubleshooting.....	6
D. TECHNICAL SUPPORT.....	8
9. Technical Support.....	8
E. CERTIFICATION AND WARRANTY.....	8
10. Certification.....	8
11. Warranty.....	9
F. ABBREVIATIONS.....	9
12. Abbreviations	9

USING THIS TECHNICAL PRACTICE

Three types of messages, identified by icons, appear in the text:



A note informs you of special circumstances.



A caution indicates the possibility of equipment damage.



A warning indicates the possibility of personal injury.

Copyright © 1997, PairGain Technologies, Inc.
 PairGain is a registered trademark, and PG-Flex is a trademark of PairGain Technologies, Inc.

A. PRODUCT OVERVIEW

1. Description and Features

- 1.1** The PairGain® PG-Flex FRC-753 List 4 Channel Unit provides eight loop start or ground start channel interfaces for Plain Old Telephone Service (POTS) between a PG-Flex Remote Terminal (RT) and subscribers. You can provision each of the eight circuits separately for either loop start or ground start services. Provisioning is done through the PG-Flex Line Unit Maintenance port.

The FRC-753 unit provides metallic test access to the subscriber line connection through an optional metallic bypass pair. Perform metallic bypass testing either manually or through the Pair Gain Test Controller (PGTC).

- 1.2** Features of the FRC-753 COT Channel Unit are:

- eight loop start or ground start POTS subscriber interfaces
- 64 kbps μ -Law Pulse Code Modulation (PCM) encoding
- front panel ACTIVE LEDs
- front panel FAULT LED
- PGTC compatibility
- Custom Local Area Signaling Services (CLASS) support (i.e., caller ID)
- line-side answer supervision support (reverse battery)
- forward disconnect
- distinctive ringing
- protection against secondary surges and power cross
- connection for a subscriber loop to a metallic bypass test pair
- application of ringing voltage
- detection of loop off-hook, ground start seizure, and Ring-Tip conditions

2. Front Panel

- 2.1 Figure 1 shows the FRC-753 front panel. Table 1 lists the different states and indications for the FRC-753 Channel Unit front panel LEDs.

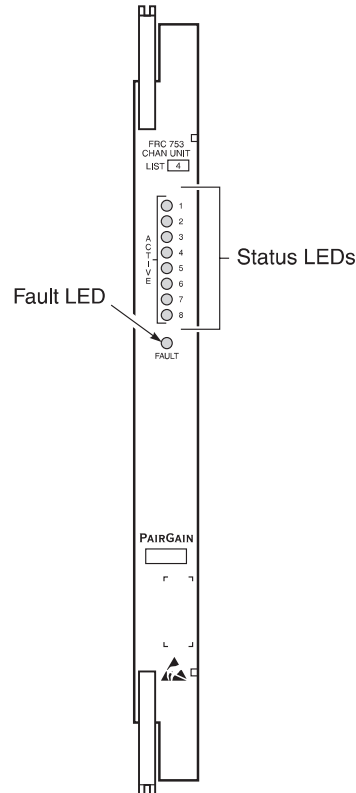

Figure 1. FRC-753 Front Panel

Table 1. FRC-753 Front Panel LEDs

LED	LED State	Indicates
ACTIVE (1 through 8)	Solid green	Channel is off hook.
	Fast flashing green	Channel is switched to the test pair.
	Slow flashing green	Channel is ringing.
	Off	Channel is on hook.
FAULT	Red	Fault detected by the unit.
	Off	No faults detected.

To reduce power at the RT, the FRC-753 LEDs extinguish after a two minute timeout period. Press and hold the ACO button on the RT Line Unit for two seconds to re-activate the LEDs for another two minutes.

3. Specifications

Electrical Characteristics

Analog Impedance	600 Ω
Subscriber Drop	530 Ω + 430 Ω handset
DC Loop Current	23 mA
Ringer Output	40 V RMS, 3 lines simultaneously, 5 REN each
End-to-End Loss	-2.5 dB ± 1.0 dB
Lightning Protection	Meets all requirements (GR-CORE-1089, Section 4)

Environmental

Operating Elevation	-200 ft. to 13,000 ft (-60 m to 4,000 m)
Temperature and Humidity	-40° F to +150° F (-40° C to +65° C) 5% to 95% (non condensing)

Physical

Weight	0.6 lb (0.3 kg)
Dimensions	
Height	12.0" (30.5 cm)
Width	1.0" (2.5 cm)
Depth	4.5" (11.4 cm)

B. FUNCTIONAL DESCRIPTION

4. Applications

4.1 The FLC-753 can be configured to provide service in any one of the following ways:

- eight independent loop start subscriber lines or
- eight ground start Private Branch Exchange (PBX) lines or
- a mixture of both loop start subscriber lines and ground start PBX lines

Figure 2 shows a typical system with loop start and ground start services.

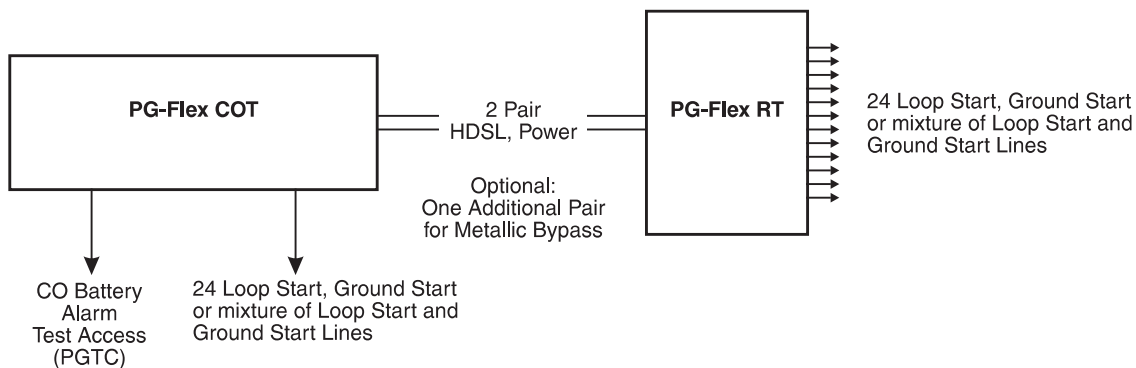

Figure 2. Typical System with Loop Start and Ground Start Capabilities

5. Operational Capabilities

5.1 FRC-753 Functions. The FRC-753 Channel Unit provides eight POTS channel interfaces between the RT and the subscriber. Each FRC-753 detects:

- loop current
- Ring trip
- Ring ground

The subscriber line battery is supplied by a constant current supply. It is sufficient to operate a telephone set over the indicated loop. The battery feed can be disconnected and the loop opened to a drop connection when a forward disconnect signal is received from the FLC-703. The battery feed can also reverse the polarity of the output as a physical signal of far end supervision.

The FRC-753 has protection from lightning and power crosses. See section 3 for specifications.

5.2 Circuit Operation. The following paragraphs define the FRC-753 circuit operation when using loop start for subscriber lines or ground start for PBX lines. Each FRC-753 circuit has an associated LED that indicates when the line is off-hook, idle, ringing, or under test. See Table 1.

5.2.1 *Loop start* idle condition is a Ring lead negative and Tip lead positive from the Central Office Terminal (COT) with the same conditions out of the RT toward the subscriber. The following occurs when the calling line goes off-hook:

- loop current flows and is detected by the FRC-753
- FLC-703 receives an off-hook signal from the RT
- FLC-703 generates an off-hook signal to the Central Office (CO) to begin current flow
- CO sends dial tone
- FRC-753 recognizes dial pulses or Dual Tone Multi Frequency (DTMF) signaling, from the subscriber and forwards these as loop current breaks, or DTMF signaling, to the CO

The following occurs for an incoming call:

- FLC-703 detects a ringing signal from the CO
- FLC-703 signals the FRC-753 which then connects ringing to the subscriber
- subscriber line goes off-hook and the FRC-753, via the FLC-703, signals the CO to disconnect ringing and establish an audio path

5.2.2 *Ground start* idle condition is a Tip lead open and Ring lead negative into the COT and Tip lead open and Ring lead negative at the RT. The following occurs when a PBX requests service for an outgoing call by grounding the Ring lead at the RT:

- FRC-753 signals the FLC-703
- FLC-703 operates a Ring ground relay that requests dial tone from the CO (this makes the circuit busy, or seizes it, for outgoing calls to prevent others from using it, i.e., prevents glare where different users can seize a line at the same time)
- CO sends dial tone and grounds the Tip to signal the PBX to begin dialing
- FLC-703 detects Tip ground, closes the loop between Tip and Ring, and signals the FRC-753 to send Tip ground to the PBX
- PBX removes the original Ring ground condition and completes the loop (Tip and Ring)

The following occurs for an incoming call:

- FLC-703 detects a ringing signal from the CO, along with Tip ground
- FLC-703 signals the FRC-753 which then connects Tip ground and ringing to the PBX
- PBX goes off-hook and the FRC-753, via the FLC-703, signals the CO to disconnect ringing and establish an audio path

5.2.3 When caller ID (a CLASS feature) is activated, the CO generates a signal to the subscriber between the first and second bursts of the ringing signal only (i.e., PG-Flex supports on-hook transmission).

5.2.4 The forward-disconnect function releases a called line that was left on hold or an answering set that requires a loop open to be able to turn off.

C. INSTALLATION AND TEST

6. Unpacking

6.1 Upon receipt of the equipment, proceed as follows:

- 1 Unpack each container and visually inspect it for signs of damage. If the equipment has been damaged in transit, immediately report the extent of damage to the transportation company and to PairGain. Order replacement equipment if necessary.
- 2 Check the contents versus the packing list to ensure complete and accurate shipment. If the shipment is short or irregular, contact PairGain as described in Section 11. If you must store the equipment for a prolonged period, store the equipment in its original container.

7. Installation



Observe normal electrostatic discharge precautions when handling electronic equipment. Do not hold electronic plug-ins by their edge. Do not touch components or circuitry.

7.1 Install FRC-753. Insert the FRC-753 into the shelf and observe that all LEDs:

- turn ON for approximately two seconds
- scan from top to bottom
- turn OFF

If the LEDs do not follow the above sequence, see Table 1.



Use List 3 or higher PG-Flex CO and RT Line Units when activating the ground start feature.

7.2 Provision the FRC-753. Provision the FRC-753 using the FLL-712 List 3 CO Line Unit practice. For each channel provisioned, select loop start or ground start.

7.3 Connect Cabling. Place a connection from the subscriber interface to the RT termination.

- 7.4 Verify Operation.** Verify the following after the system is powered up and HDSL communication is synchronized:
- 1** Observe that the front panel ACTIVE indicators are all OFF and the FAULT indicator is off (no calls are in progress).
 - 2** Test circuits for loop start:
 - a** Place an outgoing call for each subscriber circuit provisioned and observe that the ACTIVE LED tracks the progress of the call (Table 1).
 - b** Place an incoming call for each subscriber circuit provisioned and observe that the ACTIVE LED tracks the progress of the call (Table 1).
 - 3** Test circuits for ground start (circuits must be provisioned for ground start per section 7.2):
 - a** Place an outgoing call for each subscriber circuit provisioned and observe that the ACTIVE LED tracks the progress of the call (Table 1).
 - b** Place an incoming call for each subscriber circuit provisioned and observe that the ACTIVE LED tracks the progress of the call (Table 1).

8. Troubleshooting

- 8.1 Subscriber Drop Testing.** For PG-Flex subscriber drop testing from the CO, select and connect any subscriber drop to a metallic test pair at the RT. PG-Flex extends this connection to the COT where it can be switched onto the test access bus or to the corresponding subscriber line on the COT channel card.
- Activate test access through the RS-232 maintenance port located on the front of the COT Line Unit using an ASCII terminal.
- 8.2** Table 2 provides troubleshooting procedures based on indications displayed by the FRC-753 Channel Unit front panel status LEDs or customer reported problems.

Table 2. FRC-753 RT Channel Unit Troubleshooting

Indication	Problem	Action
FAULT LED ON	The FRC-753 processor has detected a fault.	Remove and re-insert the Channel Unit. If the FAULT LED does not extinguish, replace the Channel Unit.
Troubleshooting based on customer-originated trouble reports		
No Dial tone, Can't Dial	<ul style="list-style-type: none"> • faulty RT or COT Channel Unit • facility short/open • CO switch problem 	<ol style="list-style-type: none"> 1 Lift the subscriber pair at the network interface. If dial tone is present and you can place a call, refer the problem to the customer per local practice. 2 If you cannot hear dial tone or cannot place a call at the network interface (with the subscriber pair lifted), check for dial tone at the RT. If dial tone is present, check the pair between the RT and the network interface. If no dial tone is present, replace the RT Channel Unit. 3 If the problem still exists, re-insert the original RT Channel Unit and replace the COT Channel Unit. Test for operation. 4 If the problem still exists, refer the problem to the CO switch.
Phone Doesn't Ring	<ul style="list-style-type: none"> • high-resistance subscriber line short • faulty RT or CO Channel Unit • loop length too long 	<ol style="list-style-type: none"> 1 Lift the subscriber pair at the network interface. If ringing is present, refer the problem to the customer per local practice. 2 If ringing is not present, check for ringing at the RT. If ringing is present, check the pair between the RT and the network interface. If no ringing is present, replace the RT Channel Unit. If ringing is still not present, check a circuit on another Channel Unit. If ringing is still not present, replace the RT Line Unit. 3 If ringing is still not present at the RT, re-insert the original Channel Unit and Line Unit. Test for ringing at the COT. 4 Test for ringing into the COT from the CO switch. If no ringing is present, refer the trouble to the CO switch. If ringing is present, replace the COT Channel Unit. Test again for ringing at the network interface. If ringing is still not present, contact PairGain technical assistance per section 9. 5 Verify the resistance of the copper loop between the RT Enclosure and the network interface is less than 530 Ω.
Phone doesn't stop ringing	<ul style="list-style-type: none"> • faulty subscriber instrument • faulty RT Channel Unit • loop length too long 	<ol style="list-style-type: none"> 1 Test for ring trip at the network interface. If the ringing is tripped, refer the trouble to the customer per local practice. 2 If the ringing is not tripped, test for tripping at the RT. If ring trip does occur, check the loop for excessive length. If ring trip does not occur, replace the RT Channel Unit. If ring trip still does not occur, contact PairGain technical assistance per section 9. 3 Verify the resistance of the copper loop between the RT Enclosure and the network interface is less than 530 Ω.
Can't Hear, Can't Be Heard	<ul style="list-style-type: none"> • subscriber problem • faulty RT or COT Channel Unit 	<ol style="list-style-type: none"> 1 Lift the subscriber line at the network interface and check the signal level. If correct, refer trouble to the customer per local practice. 2 If the level is too low, check the level at the RT. If the level is correct at the RT, check the pair between the RT and the network interface. If the level is too low at the RT, replace the RT Channel Unit. 3 If the level is still too low, re-insert the original RT Channel Unit. 4 Check the level at the COT coming from the CO switch. If it is correct, replace the COT Channel Unit. If it is not correct, refer the problem to the CO regarding the switch. 5 If the level is still not correct, re-insert the original COT Channel Unit. Contact PairGain technical assistance per section 9.

D. TECHNICAL SUPPORT

9. Technical Support

- 9.1** PairGain Technical Assistance is available 24-hours-a-day, 7-days-a-week by contacting PairGain Customer Service Engineering group at:
- Telephone:** (800) 638-0031 or (714) 832-9922
- Fax:** (714) 832-9924
- 9.2** During normal business hours (8:00 AM to 5:00 PM, Pacific Time, Monday - Friday, excluding holidays), technical assistance calls are normally answered directly by a Customer Service Engineer. At other times, a request for technical assistance is handled by an on-duty Customer Service Engineer through a callback process. This process normally results in a callback within 30 minutes of initiating the request.
- 9.3** In addition, PairGain maintains a computer bulletin board system for obtaining current information on PairGain products, product troubleshooting tips and aids, accessing helpful utilities, and for posting requests or questions. This system is available 24-hours-a-day by calling (714) 730-3299. Transmission speeds up to 28.8 kbps are supported with a character format of 8-N-1.

E. CERTIFICATION AND WARRANTY

10. Certification

- 10.1** **FCC Compliance.** The FRC-753 List 4 Channel Unit complies with the limits for Class A digital devices pursuant to Part 15 of the FCC rules. These limits are designed to provide reasonable protection against harmful interference when the equipment is operated in a commercial environment. This equipment generates, uses and can radiate radio frequency energy and, if not installed and used in accordance with the instruction manual, may cause harmful interference to radio communications. Operation of this equipment in a residential area is likely to cause harmful interference in which case the user will be required to correct the interference at his own expense.
- 10.2** Refer to the installation section of the appropriate instruction manual for the unit you are installing to get information on:
- cabling
 - proper connections
 - grounding
 - line power
- 10.3** All wiring external to the product(s) should follow the provisions of the current edition of the National Electrical Code.

11. Warranty

- 11.1** PairGain Technologies warrants this product to be free of defects and to be fully functional for a period of 5 years from the date of original shipment, given proper customer installation and regular maintenance. PairGain will repair or replace any unit without cost during this period if the unit is found to be defective for any reason other than abuse or improper use or installation.
- 11.2** This module should not be field repaired. If it fails, replace it with another unit and return the faulty unit to PairGain for repair. Any modifications of the unit by anyone other than an authorized PairGain representative will void the warranty.
- 11.3** If a unit needs repair, call PairGain for a Return Material Authorization (RMA) number and return the defective unit, freight prepaid, along with a brief description of the problem, to:
- PairGain Technologies, Inc.
14402 Franklin Avenue
Tustin, CA 92780-7013
ATTN: Customer Repair Facility
- 11.4** PairGain will continue to repair faulty modules beyond the warranty program at a nominal charge. Contact your PairGain sales representative for details and pricing.

F. ABBREVIATIONS

12. Abbreviations

CLASS	Custom Local Area Signaling Services
CO	Central Office
COT	Central Office Terminal
DTMF	Dual Tone Multi Frequency
MLT	Mechanized Loop Testing
PBX	Private Branch Exchange
PCM	Pulse Code Modulation
PGTC	Pair Gain Test Controller
POTS	Plain Old Telephone Service
RMA	Return Material Authorization
RT	Remote Terminal

Corporate Office
14402 Franklin Avenue
Tustin, CA 92780

Tel: (714) 832-9922
Fax: (714) 832-9924



PAIRGAIN
THE COPPEROPTICS COMPANY