

PG-FLEX™ 8 CHANNEL RT POTS UNIT MODEL FRC-753

List #	PairGain Part #	CLEI Code
1	150-1353-01	VARHCGECAA
2	150-1353-02	VARHCGGCAA

CONTENTS	PAGE
A. PRODUCT OVERVIEW	
1. DESCRIPTION AND FEATURES	2
2. APPLICATIONS	2
3. SPECIFICATIONS	3
4. CERTIFICATION	4
5. WARRANTY	4
B. FUNCTIONAL DESCRIPTION	
6. OPERATIONAL CAPABILITIES	6
7. FRONT PANEL	6
C. INSTALLATION AND TEST	
8. UNPACKING	6
9. TURN-UP AND TESTING	6
10. TROUBLESHOOTING	6



Figure 1. FRC-753 COT Channel Unit Front Panel. The PairGain FRC-753 provides eight POTS interfaces between a PG-Flex Remote Terminal and the subscriber.

CAUTION

This product incorporates static sensitive components.
 Proper electrostatic discharge procedures must be followed.

A. PRODUCT OVERVIEW

1. DESCRIPTION AND FEATURES

1.01 The PG-Flex FRC-753 Channel Unit provides 8 POTS interfaces between a PG-Flex Remote Terminal (RT) and subscribers. The FRC-753 Channel Unit uses μ -Law PCM encoding. The unit includes status LEDs for each line indicating idle, ringing, and off-hook conditions, as well as an LED indicating a fault condition on the Channel Unit. The unit provides metallic test access to the subscriber line for connecting through an optional metallic bypass pair.

1.02 Revision History of this practice.

Revision 02—December 18, 1996

a) Added List 2.

1.03 Features of the PG-Flex FRC-753 RT Channel Unit:

- Eight POTS subscriber interfaces
- 64 kbps μ -Law PCM encoding
- Front panel ACTIVE LEDs indicate idle, ringing, test access, and off-hook for each channel
- Front panel FAULT LED indicator simplifies troubleshooting
- Pair Gain Test Controller (PGTC) Compatibility, List 2 only

2. APPLICATIONS

2.01 Subscriber Drop Testing. For subscriber drop testing from the central office, PG-Flex is able to select and connect any subscriber drop to a metallic test pair at the RT. PG-Flex extends this connection back to the COT where it can be switched onto the test access bus, or to the corresponding subscriber line on the COT channel card.

2.02 Test access may be achieved by placing +116V on the subscriber's COT tip lead for 1.5 seconds, then removing the +116V. Depending on the configuration of the PG-Flex system, the selected subscriber drop (assuming a working metallic bypass pair) will be connected to either the corresponding COT subscriber line or to the test access bus.

2.03 The test connection will be dropped when -116V is applied to the subscriber's COT tip for 1.5 seconds, then removing the -116V.

2.04 Test access may also be activated through the RS-232 Maintenance Port located on the front of the COT Line Unit, using an ASCII terminal.

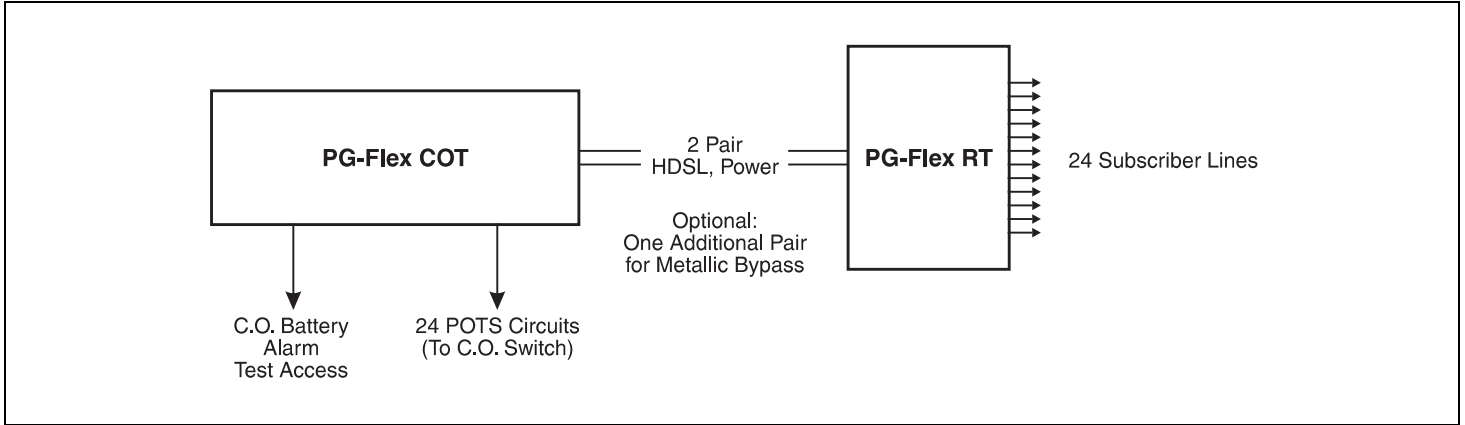

Figure 2. Typical PG-Flex Configuration.

3. SPECIFICATIONS

Analog Impedance

600 ohms

DC Loop Current

23 mA into off-hook dc resistance of 960 ohms

Ringer Output Drive

15 REN maximum per RT, 5 REN maximum per channel

RT DC Supervisory Range

960 ohms. Maximum cable loop resistance, minus 430 ohms for handset, is 530 ohms.

RT Idle State Loop Voltage (On-Hook)

Greater than 40 Vdc. Ring is negative with respect to Tip

RT Loop Closure (Off-Hook) Detection

Less than 960 ohms between Tip and Ring

RT On-Hook Detection

Greater than 10 kohms

Operating Temperature & Humidity

-40° F to +150° F (-40° C to +65° C)
5% to 95% (non condensing)

Operating Elevation

-200 ft. to 13,000 ft.
(60 m to 4,000 m)

Dimensions

Height:	12.00"	(30.5 cm)
Width:	1.00"	(2.5 cm)
Depth:	4.50"	(11.4 cm)

Weight

0.6 lb. (0.3 kg)

4. CERTIFICATION

4.01 FCC Compliance. The FRC-753 Channel Unit complies with the limits for Class A digital devices pursuant to Part 15 of the FCC rules. These limits are designed to provide reasonable protection against harmful interference when the equipment is operated in a commercial environment. This equipment generates, uses and can radiate radio frequency energy and, if not installed and used in accordance with the instruction manual, may cause harmful interference to radio communications. Operation of this equipment in a residential area is likely to cause harmful interference in which case the user will be required to correct the interference at his own expense.

4.02 Refer to the installation section of the appropriate instruction manual for the unit you are installing to get information on:

- Cabling
- Proper connections
- Grounding
- Line power

4.03 All wiring external to the product(s) should follow the provisions of the current edition of the National Electrical Code.

5. WARRANTY

5.01 PairGain Technologies warrants this product to be free of defects and to be fully functional for a period of 5 years from the date of original shipment, given proper customer installation and regular maintenance. PairGain will repair or replace any unit without cost during this period if the unit is found to be defective for any reason other than abuse or improper use or installation.

5.02 This module should not be field repaired. If it fails, replace it with another unit and return the faulty unit to PairGain for repair. Any modifications of the unit by anyone other than an authorized PairGain representative will void the warranty.

5.03 If a unit needs repair, call PairGain for a Return Material Authorization (RMA) number and return the defective unit, freight prepaid, along with a brief description of the problem, to:

**PairGain Technologies, Inc.
2120 Ritchey St.
Santa Ana, CA 92705-5101
ATTN: Customer Repair Facility
(800) 638-0031**

5.04 PairGain will continue to repair faulty modules beyond the warranty program at a nominal charge. Contact your PairGain sales representative for details and pricing.

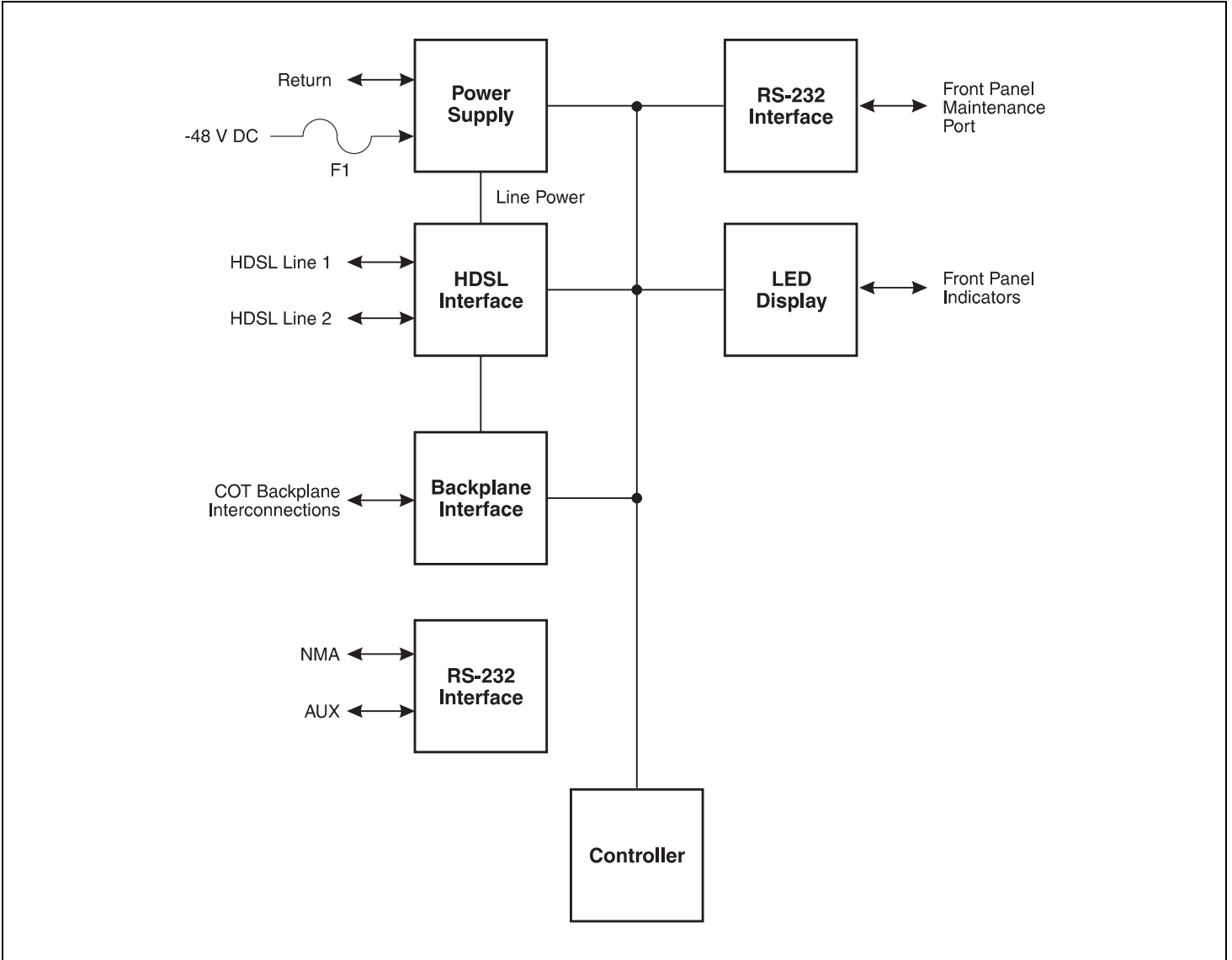

Figure 3. FRC-753 Block Diagram

B. FUNCTIONAL DESCRIPTION

6. OPERATIONAL CAPABILITIES

6.01 The FRC-753 RT Channel Unit provides 8 POTS interfaces between the RT and subscribers, and performs the following functions:

- 64 kbps μ -Law PCM encoding
- Applies ringing voltage
- Generates forward disconnect
- Detects an off-hook or ring-trip condition
- Connects a subscriber loop to a metallic test pair
- Protects against secondary surges
- Pair Gain Test Controller (PGTC) compatibility

6.02 A block diagram of the FLC-753 Channel Unit is shown in Figure 3. One 8-Channel RT POTS unit supports eight POTS interfaces.

6.03 A status LED is associated with each line to indicate whether the line is off-hook, idle, ringing, or being tested. A common fault LED indicates a general fault has been detected on the card and it should be replaced.

6.04 Test access connections to a specific line circuit are made through the maintenance terminal or by the CO switch applying the appropriate voltage on the subscriber line (see paragraphs 2.01 through 2.04).

7. FRONT PANEL

7.01 The front panel of the FRC-753 Channel Unit contains the following indicators (see Figure 1):

- **ACTIVE 1-8 LED Indicators**
Green—the channel is off-hook.
Flashing Green—(slow flash) the channel is ringing (the LED will track the ringing) or the line has been switched to the test pair.
Off—the channel is on-hook.
- **FAULT LED Indicator**
Red—a fault has been detected by the unit.
Off—no faults are detected by the unit.

C. INSTALLATION AND TEST

8. UNPACKING

8.01 Upon receipt of the equipment, proceed as follows:

1. Unpack each container and visually inspect it for signs of damage. If the equipment has been damaged in transit, immediately report the extent of damage to the transportation company and to PairGain. Order replacement equipment if necessary.
2. Check the contents versus the packing list to ensure complete and accurate shipment. If the shipment is short or irregular, contact PairGain as described in Section 5. If you must store the equipment for a prolonged period, store the equipment in its original container.

9. TURN-UP AND TESTING

9.01 Table 2 provides step-by-step turn-up and test procedures for the FRC-753 Channel Unit.

10. TROUBLESHOOTING

10.01 Table 3 provides troubleshooting procedures based on indications displayed by the front panel indicators of the FRC-753 Channel Unit.

TABLE 2. FRC-753 RT CHANNEL UNIT TURN-UP AND TESTING

CAUTION			
Observe normal electrostatic discharge precautions when handling electronic equipment. Do not hold electronic plugs by their connector edges. Do not touch components or circuitry.			
<i>Step</i>	<i>Operation</i>	<i>Action</i>	<i>Observe</i>
1	Install RT Channel Units	a. Insert each FRC-753 Channel Unit into the FRE-765 RT Enclosure.	All LEDs on the Channel Unit will turn <i>on</i> for approximately 2 seconds, then scan from top to bottom, then turn <i>off</i> .
		b. After the system has powered up, established HDSL synchronized communications, and no calls are in progress, observe the Channel Unit front panel indicators.	ACTIVE 1 <i>off</i> ACTIVE 2 <i>off</i> ACTIVE 3 <i>off</i> ACTIVE 4 <i>off</i> ACTIVE 5 <i>off</i> ACTIVE 6 <i>off</i> ACTIVE 7 <i>off</i> ACTIVE 8 <i>off</i> FAULT <i>off</i>
2	Test Subscriber Circuits	a. Test each subscriber circuit by placing and receiving calls.	ACTIVE 1 through 8 LEDs track call as described in paragraph 7.01.

Note: To reduce the power required by the Remote Terminal, the RT Channel Unit LEDs will extinguish after a two minute time out. Press and hold the ACO button on the RT Line unit for two seconds to reactivate the LEDs for another two minutes.

TABLE 3. FRC-753 RT CHANNEL UNIT TROUBLESHOOTING

<i>Indication</i>	<i>Problem</i>	<i>Action</i>
FAULT LED <i>on</i>	The processor in the RT Line Unit has stopped.	Remove and replace the RT Line Unit. If the system does not restart, replace the RT Line Unit.
<i>Troubleshooting based on customer-originated trouble reports</i>		
No Dial tone, Can't Dial	Short circuit, faulty COT, or faulty RT Channel Unit.	<ol style="list-style-type: none"> 1. Lift the subscriber pair at the RT. If dial tone is present and calls can be placed, check for shorts toward the subscriber or on the customer's premise. 2. If you cannot hear a dial tone and/or cannot make calls at the RT with the subscriber drop lifted, lift the jumper in the CO between the CO switch and the COT. If you hear a dial tone and/or can make calls at the switch, replace the COT Channel Unit and/or RT Channel Unit. Otherwise, the problem is in the CO switch.
Phone Doesn't Ring	High-resistance short on subscriber drop, faulty RT Channel Unit, or faulty RT Line Unit.	<ol style="list-style-type: none"> 1. Check for ringing at the RT. If ringing isn't present on the line under test, try ringing another line terminated on the same RT Channel Unit. If ringing is present on other lines, check for high resistance shorts on the subscriber drop. 2. If ringing isn't present on a circuit terminated on the same RT Channel Unit, try ringing a line terminated on another RT Channel Unit. If the line rings, replace the RT Channel Unit. If the line doesn't ring, replace the RT Line Unit.
Phone Doesn't Stop Ringing	Faulty subscriber station instrument, faulty RT Channel Unit, or loop length too long.	<ol style="list-style-type: none"> 1. Phone stops ringing when using a butt-in at subscriber location: <ol style="list-style-type: none"> a) Subscriber's station instrument's internal resistance is too high. Replace instrument according to local policies. 2. If phone doesn't stop ringing when using a butt-in at the subscriber location, re-test at the RT: <ol style="list-style-type: none"> a) If phone still doesn't stop ringing, replace the RT Channel Unit. b) Otherwise, loop length between RT and subscriber is too long.
Can't Hear, Can't Be Heard	Subscriber problem, faulty COT Channel Unit, or faulty RT Channel Unit.	<ol style="list-style-type: none"> 1. Lift the subscriber drop at the RT. If audible level is acceptable, there is a problem toward the subscriber. 2. If audible level is too low at the RT with the subscriber drop lifted, lift the jumper in the CO between the CO switch and the COT. If audible level is acceptable, replace the COT Channel Unit and/or RT Channel Unit. Otherwise, the problem is in the CO switch.