

HIGAIN-ETSI RS

RATE SELECTABLE HDSL UNITS

QUICK INSTALLATION GUIDE

Model	List Number	Part Number
UTU-722	1	150-1422-22
ETU-772	1	150-1432-22

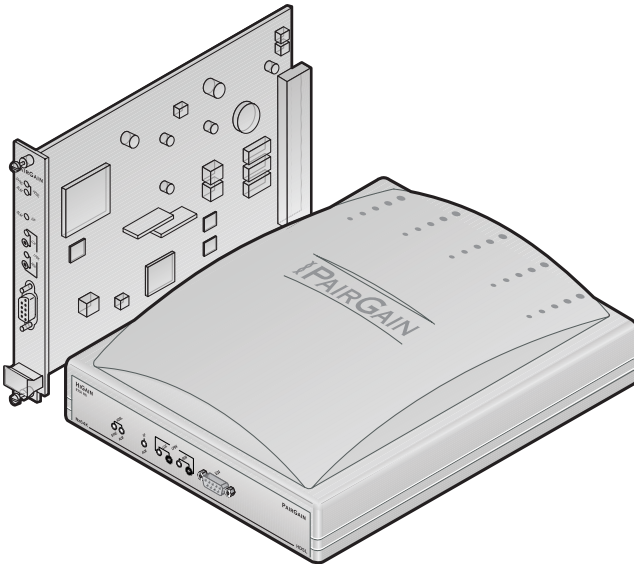

PAIRGAIN TECHNOLOGIES, INC.
ENGINEERING SERVICES
SECTION 700-722-900-02

Revision History of This Guide

Revision	Release Date	Revisions Made
01	March 23, 1999	Initial release
02	June 21, 1999	Added pinouts for ETU-772 HDSL line and console port connectors.

©Copyright 1999 PairGain Technologies, Inc.

PairGain and HiGain are registered trademarks and HiGain-ETSI is a trademark of PairGain Technologies, Inc.

Information contained in this document is company private to PairGain Technologies, Inc., and shall not be modified, used, copied, reproduced or disclosed in whole or in part without the written consent of PairGain.

Other product names mentioned in this practice are used for identification purposes only and may be trademarks or registered trademarks of their respective companies.

USING THIS GUIDE

Three types of messages, identified by icons, appear in the text.



Notes contain information about special circumstances.



Cautions indicate the possibility of equipment damage or the possibility of personal injury.

Warnungszeichen deuten darauf hin, dass Schaden am Gerät oder eine mögliche Körperverletzung riskiert wird, falls die Warnungen nicht beachtet werden.



The ESD Susceptibility symbol indicates that a device or assembly is susceptible to damage from electrostatic discharge.

DOCUMENTATION

The complete technical practice for the units described in this guide, *HiGain-ETSI RS Rate Selectable HDSL Line and Desktop Units*, section 700-722-100-xx, can be downloaded from the Customer Site portion of the PairGain Web page at www.pairgain.com. A password is required. If you do not have a password, contact your PairGain sales representative.

If you have comments on this PairGain document, send an email to technical_publications@pairgain.com. Type the product name and the section number of the document in the subject area of the email message.

TABLE OF CONTENTS

Overview	1
Rate Selectable HDSL	1
UTU-722 Line Unit.....	1
ETU-772 Desktop Unit	2
Transmission Ranges	2
Compatibility	3
Shelves and Enclosures for UTU-722	3
Connector Adapters for ETU-772	3
Front Panels	4
ETU-772 Rear Panel	7
Installation	8
Inspection	8
Safety	8
Line Unit Installation	9
Desktop Unit Installation	9
HDSL Startup and Synchronization.....	11
System Configuration	12
Maintenance Terminal Connection.....	12
Logging On	13
Navigating Menus	14
System Settings.....	15
LTU and NTU Interface Settings.....	16

Viewing Status **17**

 Main Console Screen..... 17

 Monitor Screens 19

 Monitor LTU and NTU Interface Screens 19

 Monitor HDSL Span Screen 20

PairGain Regional Sales Offices **21**

Documentation **22**

Technical Support **22**

Equipment Repair **23**

Warranty **23**

Compliance **24**

OVERVIEW

This guide contains installation information for the PairGain® HiGain-ETSI™ UTU-722 List 1 and ETU-772 List 1 Rate Selectable (RS) line and desktop units.

RATE SELECTABLE HDSL

HiGain-ETSI RS is a single pair High-bit-rate Digital Subscriber Line (HDSL) solution that offers extended reach capabilities through the use of industry-leading multi-rate DSL technology. The UTU-722 and ETU-772 deploy HDSL in networks using a single pair of copper wire running at speeds between 64 kbps and 256 kbps. The HDSL line rates are either menu selected in time slot increments of 64 kbps or derived automatically from the Terminal Transmission (TT) clock received at the Nx64k serial data port from the Network Data Terminal Equipment (DTE). Transmission ranges vary according to the rate selected. Depending on noise environment, ranges of up to 8.5 km (5.3 miles) are possible at the lowest-selectable HDSL line rates (64 and 128 kbps).



HiGain-ETSI RS units are not backward compatible with standard HDSL or management unit firmware. The installed firmware must be that designed for rate selectable units.

HiGain-ETSI RS units must have the same payload rates available. An LTU set for a rate of 768 kbps will not function with an NTU whose maximum available rate is 256 kbps.

UTU-722 LINE UNIT

The UTU-722 can be configured as a Line Termination Unit (LTU) or Network Termination Unit (NTU). The default configuration is NTU.

When configured as an LTU, the UTU-722 serves as the Exchange Office side of a repeaterless, HDSL transmission system. The LTU-configured unit connects to an NTU-configured unit (UTU-722 or ETU-772) over one twisted-pair of copper wire, completing the HDSL transmission system.

The UTU-722 has an Nx64k serial data interface with user-selectable protocols that include V.35, V.36, X.21, and RS-530 (RS-449). The UTU-722 accepts the DTE payload at its Nx64k serial data port and transports the data to the remote unit at the selected HDSL rate. The UTU-722 requires -36 to -72 Vdc from a local power supply or an enclosure's AC-to-DC power supply; it does not supply power to other HDSL units.

ETU-772 DESKTOP UNIT

The ETU-772 is housed in a plastic enclosure with interface and power connectors for use as an integrated desktop unit. All functions of the ETU-772, with exception of power requirements, are identical to the UTU-722. The ETU-772 requires a source of 100 to 240 volt, 50 or 60 Hz, AC power.

TRANSMISSION RANGES

Transmission ranges assume the presence of noise according to the ETSI model described in TS 101 135. The expected Bit Error Rate (BER) under this model is 10^{-7} . The transmission ranges in such a noise environment at the various HDSL line rates over one twisted-pair of 0.4 mm and 0.51 mm copper wire are listed below.

Transmission Ranges with ETSI Noise

HDSL Line Rate (kbps) ^(a)	Wire Size and Transmission Range (with ETSI Noise)	
	0.4 mm (26 AWG) Single Twisted-Pair Copper Wire	0.51 mm (24 AWG) Single Twisted-Pair Copper Wire
128	5.0 km (16,404 ft.)	6.3 km (20,669 ft.) ^(b)
256	4.1 km (13,451 ft.)	5.1 km (16,732 ft.)

(a) A selected HDSL line rate of 64 kbps is transmitted at 128 kbps.

(b) The maximum no-noise transmission range is approximately 8.5 km.

COMPATIBILITY

The UTU-722 and ETU-772 are compatible with the following PairGain HiGain-ETSI products.

Shelves and Enclosures for UTU-722

- EMS-830 Exchange Office Management Shelf, rear connector access (part number 150-1400-01).
- EMS-831 Exchange Office Management Shelf, front connector access (part number 150-1401-01).
- EMS-832 Exchange Office Management Shelf, front connector access (part number 150-1402-01).
- ERE-810 Single-Slot Remote Enclosure. (part number 150-1410-01).
- ERE-811 Single-Slot Remote Enclosure with internal AC power supply (part number 150-1411-01).
- ERE-821 Dual-Slot Remote Enclosure with internal AC power supply (part number 150-1416-01).
- ERE-826 Single-Slot Remote Enclosure (part number 150-1412-01).

Connector Adapters for ETU-772

- ECA-800 D25M to M34F connector adapter for V.35 (part number 150-1470-01).
- ECA-801 D25M to D15F connector adapter for X.21 (part number 150-1471-01).
- ECA-802 DB9M to RJ-45 connector adapter for HDSL (part number 150-1472-01).
- ECA-804 DB9M to 4-position terminal block connector for HDSL (part number 150-1474-01).
- ECA-807 DB25M to DB37F connector adapter for RS-449 (part number 150-1477-01).

FRONT PANELS

The components on the UTU-722 and ETU-772 front panels are shown below. Their functions are described on [page 5](#) and [page 6](#).

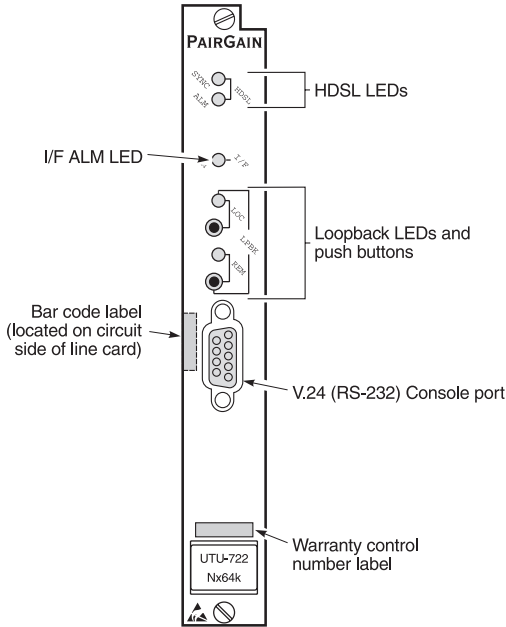

UTU-722 Line Unit Front Panel

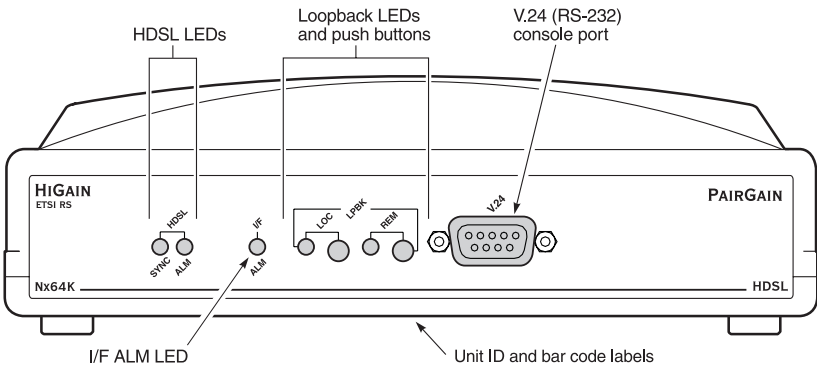

ETU-772 Desktop Unit Front Panel

UTU and ETU Front Panel Components

Item	Function
HDSL SYNC LED	Displays synchronization state for the HDSL loop.
HDSL ALM LED	Displays alarm state for the HDSL loop.
I/F ALM LED	Displays the Nx64k interface (I/F) alarm state.
LOC LPBK LED	Displays local (LOC) loopback state.
LOC LPBK Button	Activates the local HDSL analog loopback.
REM LPBK LED	Displays remote (REM) loopback state.
REM LPBK Button	Activates the remote interface loopback.
V.24 (RS-232) console port	Provides bi-directional communication between the unit and an external maintenance terminal through a V.24 (RS-232C) interface to allow configuration and performance monitoring through the Console screen menus.
Bar code label (all units)	Contains the serial number and part number of the unit, as indicated in both bar code and text format. Also contains the configuration number of the unit, as indicated by "CFG: Rnn," where <i>nn</i> is the configuration number. For example, CFG: R07 would indicate configuration number 07.
Warranty control number label (UTU-722)	Indicates the beginning year and month of the line card warranty. Also indicates the line card revision number. For example, warranty control number "803R07" would indicate a warranty beginning in the year 1998 (8), during the month of March (03), and line card revision number R07.
Unit ID label (ETU-772)	Identifies the model number, manufacturer, part number, and input voltage range of the ETU. Includes the CE Mark, certifying that the unit is in compliance with European Telecommunications Terminal Equipment (TTE) directives 89/336/EEC and 93/68/EEC.

UTU and ETU Front Panel LED Indications

LED	Mode	Description
HDSL SYNC LED	Steady green	HDSL loop is ready to transmit and receive data across all spans.
	Slow flashing	HDSL loop acquisition is in progress for local span.
	Off	HDSL loop is not configured.
HDSL ALM LED	Steady red	Indicates: <ul style="list-style-type: none"> • Loss of sync word (LOSW) • Margin is below the set margin alarm threshold • Errored Seconds (ES) count is above threshold on any span.
	Pulsing red	Pulses for every ES on any span.
	Off	Normal transmit or receive data is in progress.
I/F ALM LED	Steady red	Loss of Clock (LOC) alarm due to loss of TT clock (Nx64k timing) or external clock (EXT timing).



For information on loopback testing and loopback LED indications, see the *HiGain-ETSI RS Rate Selectable HDSL Line and Desktop Units* technical practice, section 700-722-100-xx. See “[Documentation](#)” on page iii for information on how to obtain this practice.

ETU-772 REAR PANEL

The components on the ETU-772 rear panel are shown and described below.

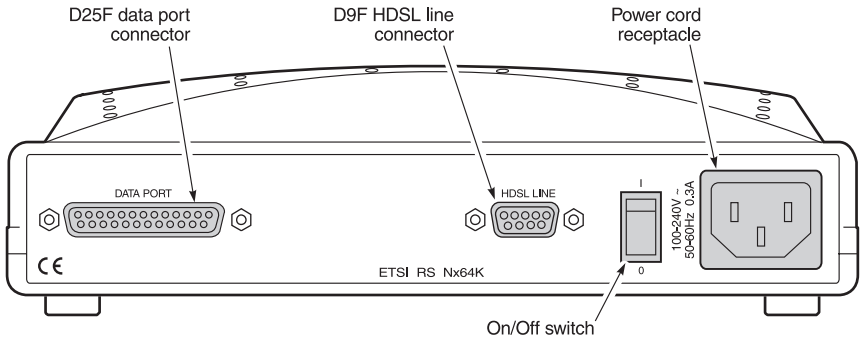

ETU-772 Desktop Unit Rear Panel

ETU-772 Rear Panel Components

Item	Description
D25F data port connector	Connects Nx64k data circuits to the enclosure.
D9F HDSL line connector	Connects the HDSL pairs to the enclosure.
Power cord receptacle	Connects an AC power cord to the enclosure.
On/Off switch	Rocker switch that allows you to turn the externally applied AC power on or off.

INSTALLATION

This section contains instructions for installation of the UTU-722 line unit and the ETU-772 desktop unit.

INSPECTION

Before installing the line or desktop unit, inspect it for signs of shipping damage. If the unit has been damaged in transit, immediately report the extent of the damage to the transportation company and to PairGain Technologies.

SAFETY

To ensure your safety when servicing and installing this equipment, please take the following precautions:



Be careful when installing or modifying telephone lines. Dangerous voltages can be present. It is unsafe to install telephone wiring during a lightning storm.

Always disconnect all telephone lines and power connections before servicing or disassembling this equipment. For performance and safety reasons, only power supplies listed for use with telephone equipment by a locally recognized organization should be used with PairGain equipment. All wiring external to the product should follow the local wiring codes.

Walte Vorsicht beim Installieren oder Ändern von Telefonlinien. Gefährliche Spannungen könnten anliegen. Es ist nicht sicher während eines Gewitters Telefondrähte zu installieren.

Bevor Wartung oder Auseinandernehmen des Gerätes müssen immer alle Telefon- und Netzkabel ausgezogen werden. Aus Leistungs- und Sicherheitsgründen sollten nur Netzteile die für Telefongeräte zugeschnitten und von einem renommierten Geschäft vertrieben werden mit PairGain Geräten verwendet werden. Alle externen Verdrahtungsarbeiten sollten nach den hiesigen Elektrizitätsvorschriften ausgeführt werden.

LINE UNIT INSTALLATION

To install the UTU-722 line unit into a shelf or remote enclosure:



The chassis ground of the shelf or remote enclosure receiving these units must be connected to earth ground for protection of the equipment and for safety of personnel.

Other protection is required when the network side of the equipment is extended to an outside facility.

- 1 Install the line unit into the appropriate slot (1 through 16) of a shelf or into a single- or dual-slot remote enclosure. (See [“Compatibility” on page 3.](#))
- 2 Connect the power source as instructed in the technical practice for the shelf or remote enclosure in which the line unit is installed.
- 3 If configuring the line unit as an LTU, power up the shelf and proceed as instructed on pages [12](#) through [15](#) to access the Local Unit Role option in the *Config System Settings* menu (the default setting is NTU).
- 4 Connect the data port and HDSL line cabling as instructed in the technical practice for the shelf or remote enclosure in which the line unit is installed.
- 5 Set the DTE interface (TT clock) for the default HDSL payload rate of 256 kbps (4 time slots).

DESKTOP UNIT INSTALLATION

To install an ETU-772 desktop unit:

- 1 Insert the AC power cord into the power cord receptacle on the ETU rear panel.
- 2 Plug the power cord into a source of 100 to 240 volt, 50 or 60 Hz AC power.
- 3 If configuring the desktop unit as an LTU, power up the unit and proceed as instructed on pages [12](#) through [15](#) to access the Local Unit Role option in the *Config System Settings* menu (the default setting is NTU).

- 4 Connect the data port cable from the DTE to the data port connector on the ETU-772 rear panel.
- 5 Connect the HDSL line cable to the HDSL line connector on the ETU rear panel. The pinouts for the HDSL line connector are listed in the following table.

HDSL Line Connector (DB9F) Pinouts

Pin*	Signal	Description
4	HDSL_RING_A	HDSL Ring Loop 1
9	HDSL_TIP_A	HDSL Tip Loop 1
1	HDSL_RING_B	HDSL Ring Loop 2
6	HDSL_TIP_B	HDSL Tip Loop 2

* No other pins are used.

- 6 Set the DTE interface (TT clock) for the default HDSL payload rate of 256 kbps (4 time slots).

HDSL STARTUP AND SYNCHRONIZATION

At startup, a HiGain-ETSI RS LTU confirms that it is communicating with a HiGain-ETSI RS NTU. The LTU then synchronizes the NTU configuration with its own configuration.

Power up the LTU and NTU. The following synchronization sequence should occur:

- 1 Power up the shelf or enclosure where the unit(s) are installed.
- 2 Confirm the following:
 - The HDSL ALM LED is on and the HDSL SYNC LED flashes once per second as the units self-configure and establish synchronization.
 - After approximately 60 seconds the HDSL ALM LED is off and the HDSL SYNC LED is a steady green. The units are now ready for configuration through the console screen menus.



If the HDSL SYNC LED continues to flash after 90 seconds, the HDSL line is faulty, the Local Unit Role is not configured as LTU, or one of the units is not a rate selectable unit. Check for the correct line units and Local Unit Role. Test the HDSL line using the loopbacks described in technical practice 700-722-100-xx.

The LTU and NTU will reset and their LEDs will sequence through the startup cycle following any change to the HDSL Payload Rate option (see “[System Settings](#)” on page 15).

SYSTEM CONFIGURATION

After synchronization is established, the HDSL system can be configured and performance can be monitored from the local unit. If the HDSL link is down, the only parameters that can be changed are those on the local unit. The LTU also provides a special lockout feature that prevents users plugged into the NTU console port from changing the circuit configuration. When enabled, the maintenance terminal connected to an NTU provides a read-only view of the entire HDSL system.



The Console screen menus are not available when the HDSL line unit is under the control of a shelf management unit.

MAINTENANCE TERMINAL CONNECTION

A maintenance terminal is used to access the line unit Console screen menus. Through these menus, the HDSL system is configured, monitored, tested, and its circuit inventory is displayed.

To connect a maintenance terminal:

- 1 Connect a standard serial cable from the maintenance terminal COM port to the line unit's front panel console port. The pinouts for the console port and maintenance terminal connectors are shown in the diagram on the following page.
- 2 Configure the maintenance terminal for the following communication settings:
 - VT100 Emulation or ANSI (if VT100 is not available)
 - clear the modem initialization string if supported by the terminal
 - Bits per second: 1200, 2400, 4800, 9600 (default), or 19200 bps (recommended)
 - Data bits: 8
 - Parity: None
 - Stop bits: 1
 - Flow Control: None

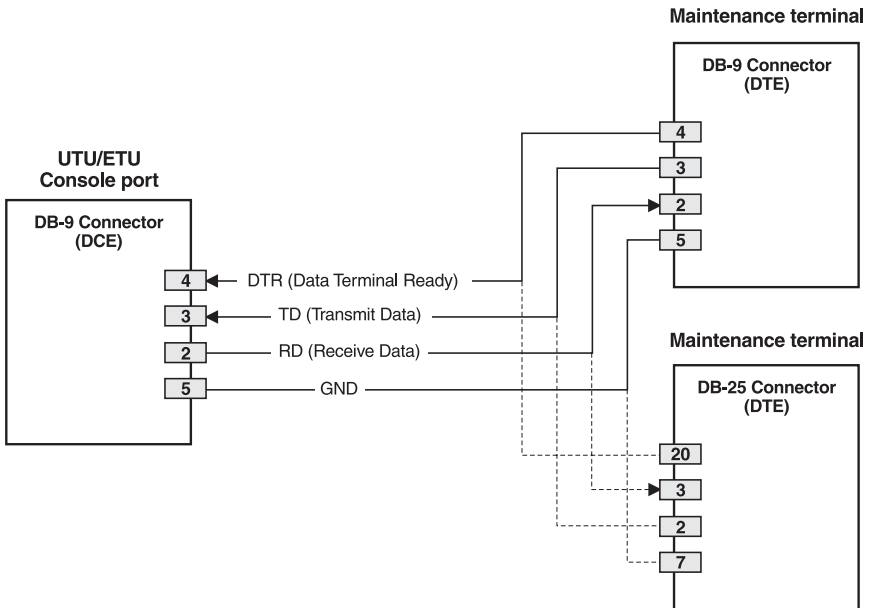

UTU/ETU Console Port and Maintenance Terminal Connector Pinouts

LOGGING ON

To log on to the maintenance terminal Console screen:

- 1 Press the **SPACEBAR** several times to activate the autobaud feature and to display the Logon Password screen.



The **ENTER** key is the factory default password. If you establish a different password, you must type the new password (single word, no spaces, up to eight characters) on a subsequent log on. If the system does not respond, verify that the Hardware Flow Control of the maintenance terminal is set to NONE.

- 2 Type the password at the prompt or press **ENTER** if a password has not been established. The Console screen menu bar displays.

NAVIGATING MENUS

Use the keys described in the following table to navigate the Console screen and its menus.

Console Screen Navigation Keys

These Keys	Perform this Function
Alpha-numeric keys	Type the underlined or highlighted letter to select and execute a menu item. For example on the Console screen menu bar, type C to access the Config drop-down menu. Also use these keys to enter values in text fields. For example, on the Config Date and Time menu, type the date in a DD/MM/YY format.
↑ and ↓ keys	Press the ↓ key to access a Console screen drop-down menu. For example, press the ↓ key on Config to access the Config drop-down menu. Or press the ↑ and ↓ keys to highlight a sub-menu item, then press ENTER to select the item. For example, press the ↓ key to highlight Config Alarms, then press ENTER to view the sub-menu.
TAB key	Provides same function as the ↓ key.
← and → keys	Moves horizontally across the Menu bar, except when in a text entry field.
CTRL + E	CTRL + E moves up one line in the History screens.
CTRL + X	CTRL + X moves down one line in the History screens.
CTRL + C	CTRL + C performs the page-down function in the History screens.
CTRL + R	CTRL + R performs the page-up function in the History screens.
SPACEBAR	Selects options displayed for current menu item. For example, to select MANUAL or Nx64k AUTO mode from the Config System Settings menu: <ul style="list-style-type: none"> press the ↓ key to highlight the HDSL Rate Mode option, then press the SPACEBAR until the desired option (MANUAL or Nx64k AUTO) is highlighted.
ESC	Exits the current screen and returns to the previous screen. Selection changes made on the current screen are discarded. Press ESC while in a text field to cancel the text entry and restore the old value.
ENTER	Applies all selections on the current screen. For example, to select an HDSL payload rate from the Config System Settings menu: <ul style="list-style-type: none"> press the ↓ key to highlight the HDSL Payload Rate option, then type the desired number of time slots (1 to 4) and press ENTER to display the selected HDSL payload rate (in MANUAL mode only).

SYSTEM SETTINGS

The following table lists the settings available in the *Config System Settings* menu. The settings in boldface type are factory default settings.

Settings in Config System Settings Menu

Settings	Description
Application Mode ^(a)	
SINGLE	System uses a single pair of twisted copper wire to transport data.
HDSL Rate Mode	
MANUAL	Selects the mode by which the HDSL payload rate will be set. HDSL payload rate is set by number of time slots entered for the HDSL Payload Rate option. ^(b) Each time slot is 64 kbps.
Nx64K AUTO	HDSL payload rate is set by TT clock input at Nx64k data port.
HDSL Payload Rate ^(c)	
256 kbps/4	Typing a time slot value of 1 through 4 and pressing ENTER sets and displays the HDSL payload rate (in MANUAL mode only). Payload rate is automatically set in Nx64K AUTO mode. ^(d) ^(e)
Remote Console Access	
ALLOWED	Selects whether a maintenance terminal connected to an NTU can affect system changes or is read-only. This field may be set only at the LTU. NTU Console screens can be used to configure the system.
BLOCKED	NTU Console screens are read-only. The LOC and REM pushbuttons on the NTU are also disabled. System changes can only be made from the LTU.
Protect Switch Mode	Not available on Nx64k serial data port units.
Local Unit Role	
LTU	Configures UTU or ETU as LTU (master) or NTU (slave). The default configuration is NTU (slave). Configures UTU or ETU as LTU (master). The LTU-configured rate selectable UTU/ETU does not provide line power to other HDSL units.
NTU	Configures UTU or ETU as NTU (slave). The NTU-configured rate selectable UTU/ETU does not provide line power to other HDSL units.

(a) SINGLE is the only application mode.

(b) UTU-722 and ETU-772 have 4 time slots available for rates of 64 kbps to 256 kbps.

(c) An HDSL Payload Rate of 64 kbps (1 time slot) is transmitted at 128 kbps.

(d) Payload rates in both the MANUAL and Nx64K AUTO modes are displayed in the Config LTU and Config NTU Interface menus as Data Rate/# of TSS (data rate/number of time slots).

(e) Changing the HDSL Payload Rate or Local Unit Role causes the unit to reset and the LEDs to cycle. Log on again by pressing the **SPACEBAR** several times.

LTU AND NTU INTERFACE SETTINGS

The following table lists the settings available in the Config LTU and Config NTU Interface menus. The settings in boldface type are factory default settings.

Settings in Config LTU and Config NTU Interface Menus

Settings	Description
Primary Timing Source ^(a)	Selects the clock source for the HDSL transmit direction. Choices are: <ul style="list-style-type: none"> • INT - Internal Oscillator • EXT - External 2.048 MHz clock (UTU-722 only) • Nx64k - Nx64k Serial Data port receive clock (TT) • HDSL - Recovered clock from received HDSL data
Nx64k Port	
Interface Type	Select the interface standard for serial data port. Choices are: V.35, V.36 , X.21, and RS-530.
Data Rate/# of TSs	Read-only display of HDSL data rate and corresponding number of time slots (TSs) as set automatically by TT clock (Nx64K AUTO mode) or by HDSL Payload Rate option in Config System Settings menu (MANUAL mode). Default setting is 256kbps/4 .
Beginning TS	Read-only display of beginning time slot. For these units Beginning TS is always 0 (zero).
Transmit Clock	Selects the transmit data (SD) clock as External (EXT), Internal Rising Edge (INT_RISING), or Internal Falling Edge (INT_FALLING). Transmit clock is always EXT if the Timing Source is Nx64k.
CTS DSR RLSD	Specifies one of three methods the LTU/NTU uses to generate the Clear to Send (CTS), Data Set Ready (DSR), and Received Line Signal Detect (RLSD) control signals for the V.35/V36 port. The V.35/V.36 port is hardware-configured as DCE. Set each of these parameters to match the requirements of the application. Choices are: <ul style="list-style-type: none"> • STD (standard) - The output control signal follows the ITU standards • ON (force ON) - Control signal is always ON • OFF (force OFF) - Control signal is always OFF
LL/RL	Selects whether the LTU/NTU responds to (enabled) or ignores (disabled) the Local Loopback (LL) and Remote Loopback (RL) input control signals. The enabled (ENA) status appears on the display.

(a) Primary Timing Source automatically set to Nx64k in Nx64K AUTO mode.

VIEWING STATUS

View status using a maintenance terminal or PC running a terminal emulation program connected to the unit's V.24 (RS-232) console port.

MAIN CONSOLE SCREEN

The main Console screen displays a summary of LTU and NTU circuit configuration, as well as performance statistics and alarm status for each interface.

The following table lists the information displayed in each field of the main Console screen.

Information Displayed in Main Console Screen

Field	Description
Circuit Configuration	
V.35/V.36/X.21/ RS-530	Indicates the interface standard for Nx64k serial data port.
<i>n</i> k	Indicates the data rate in number of kbps (<i>n</i> k) mapped to the Nx64k interface.
Timing	Indicates the primary source the LTU/NTU uses for clock synchronization:
INT	Internal oscillator.
EXT	External 2.048 MHz.
Nx64k	Serial data port receive clock.
HDSL	Recovered clock from received HDSL data.
Application mode	Indicates that the Single Pair (SINGLE) application mode is in effect.
Performance	
MAR1	Displays the Margin value for each HDSL interface or displays link status (SIG, ACQ, etc.) if the link is not up.
MAR2	Reserved

Information Displayed in Main Console Screen (Cont.)

Field	Description
ES1	Displays the ES counts for each HDSL interface. The counts are for the latest 24-hour period, calculated as the sum of the counts in the previous 95 15-minute intervals, plus the count in the current 15-minute interval.
ES2	Reserved

Alarms

The Alarms field displays a list of all active alarms at each LTU/NTU and HDSL interface.

Possible Nx64k
port alarms

LOC Loss of incoming clock (TT) at the serial data port (only enabled if the primary timing source is Nx64k or if the transmit clock mode is set to EXT).

Possible External
Clock Alarms

LOC Applies to loss of external clock when EXT timing is used. The external clock was lost for the previous second. This alarm is reset when the clock is active again.

Possible HDSL alarms

MAR1 Margin threshold has fallen below alarm threshold for the HDSL interface.

ES1 Errored second count has exceeded alarm threshold for the HDSL interface.

LOSW1 Loss of sync word for the HDSL interface. Remains active during restart, but not a cold start.

MONITOR SCREENS

The Monitor screens display the signal activity at the LTU/NTU serial data port, and the 24-hour error counts and other information from the HDSL Span 1 interface.

Monitor LTU and NTU Interface Screens

The following table lists the information displayed in each field of the Monitor LTU and Monitor NTU Interface screens.

Information Displayed in Monitor LTU and NTU Interface Screens

Field	Description				
Nx64k Port					
Data & Clk Activity	<p>Displays the status of the TT (terminal timing), SD (transmit data), ST (send timing), RT (receive timing), and RD (receive data) signals at the Nx64k port at one-second intervals. Asterisks (**) indicate an active line. Dashes (--) indicate an inactive line. Displayed fields are:</p> <table> <tr> <td>From DTE:</td> <td>From DCE:</td> </tr> <tr> <td>TT SD</td> <td>ST RT RD</td> </tr> </table>	From DTE:	From DCE:	TT SD	ST RT RD
From DTE:	From DCE:				
TT SD	ST RT RD				
Ctrl Signal State	<p>Displays the status of the RTS (ready to send), DTR (data terminal ready), RL, LL, CTS, DSR, RLSD, and TM (test mode) control signals at the Nx64k port at one-second intervals. ON indicates an active line. OFF indicates an inactive line. Displayed fields are:</p> <table> <tr> <td>From DTE:</td> <td>From DCE:</td> </tr> <tr> <td>RTS DTR RL LL</td> <td>CTS DSR RLSD TM</td> </tr> </table>	From DTE:	From DCE:	RTS DTR RL LL	CTS DSR RLSD TM
From DTE:	From DCE:				
RTS DTR RL LL	CTS DSR RLSD TM				
Clear 24 Hour History	Not available from this screen on Nx64k serial data port units. Use clear history options in console screen History Menu.				

Monitor HDSL Span Screen

The following table lists the information displayed in each field of the Monitor HDSL Span 1 screen.

Information Displayed in Monitor HDSL Span 1 Screen

Field	Description
Current Margin (dB) (MAR)	Indicates the excess signal-to-noise ratio relative to a 10^{-7} bit error rate. The normal range of a typical margin is from 6 to 22 dB, with a value of 6 dB corresponding to a predicted BER of 10^{-10} .
Low Margin (dB)	Indicates the lowest margin since startup or the last clearance of the 24-hour history.
High Margin (dB)	Indicates the highest margin since startup or the last clearance of the 24-hour history.
Pulse Attenuation (dB)	Indicates the attenuation of the 2B1Q pulse from the distant end. This value is related to the cable pair's loss at 292 KHz. The normal range of pulse attenuation is from 1 to 41 dB.
Errored Seconds (ES)	The number of one-second intervals in which at least one HDSL CRC-6 error or loss of Sync Word (LOSW) was detected on the HDSL span during the last 24 hours.
Unavailable Seconds (UAS)	The number of seconds that the HDSL span was down during the last 24 hours.
HDSL Tip/Ring Reversal	Indicates whether the two conductors of the HDSL span are correctly connected or have been interchanged. The system automatically compensates for an interchange of wire leads.
Clear 24 Hour History	Not available from this screen on Nx64k serial data port units. Use clear history options in console screen History Menu.

PAIRGAIN REGIONAL SALES OFFICES

Customer assistance, sales, and product information is available at PairGain's regional sales offices. Contact the PairGain® regional sales office at the location serving your area.

PairGain Regional Sales Offices

Region	Location	Hours	Telephone Number	Fax Number
United States and Canada	Tustin, California USA	24-hours-a-day, 7-days-a-week	+714.832.9922	+714.832.9908
Latin America	Miami Beach, Florida USA	Monday - Friday, 9:00AM to 5:00PM	+305.957.8100	+305.949.5804
	Campinas, Brasil	Monday - Friday, 8:00AM to 5:00PM	+55.19.865.9205	+55.19.865.9202
Europe	Switzerland	Monday - Friday, 8:00AM to 5:30PM	+41.56.483.4400	+41.56.483.4401
Middle East and Africa	Dubai, U.A.E.	Sunday - Thursday, 9:00AM to 6:00PM	+971.4.343.4949	+971.4.343.0656
Asia Pacific and China	Hong Kong (N.E. Asia)	Monday - Friday 9:00AM to 5:00PM	+852.2802.2918	+852.2802.2789
	Beijing (N. China)	Monday - Friday 8:30AM to 5:00PM	+86.10.6846.6856	+86.10.6847.6857
	Guangzhou (S. China)	Monday - Friday 8:30AM to 5:00PM	+86.20.8387.7153	+86.20.8387.3011

ORDERING PROCEDURE

Orders may be placed through PairGain regional sales offices by telephone, fax or, mail. A fax is preferred.

When placing an order, please provide the following information:

- Customer purchase order number
- Ship-to and bill-to addresses
- Part numbers and quantity required
- Requested delivery date
- Preferred method of shipment.

After receiving your order, PairGain will send an Order Acknowledgment to the bill-to and ship-to addresses (unless directed otherwise).

TECHNICAL SUPPORT

PairGain Technical Assistance is available 24 hours a day, 7 days a week by contacting PairGain Customer Service Engineering group at:

Telephone: (800) 638-0031 or (714) 832-9922

Fax: (714) 832-9924

Email: support@pairgain.com

During normal business hours (7:30 AM to 5:30 PM, Pacific Time, Monday through Friday, excluding holidays), technical assistance calls are normally answered directly by a Customer Service Engineer. At other times, a request for technical assistance is handled by an on-duty Customer Service Engineer through a callback process. This process normally results in a callback within 30 minutes of initiating the request.

EQUIPMENT REPAIR

To ensure that the equipment does not become damaged, carefully observe the following cautions:



If a problem has been isolated to this unit, do not attempt to repair it. The unit's components are not user serviceable and, therefore, must not be replaced. Please return the unit to PairGain for repairs.

Wenn eine Störung auf dieses Gerät zurückgeführt werden kann, sollte man nicht versuchen es zu reparieren. Die Geräteteile sind nicht vom Endverbraucher zu warten und müssen darum nicht ersetzt werden. Bitte senden Sie das Gerät zur Reparatur zurück an PairGain.

WARRANTY

PairGain Technologies warrants this product to be free of defects and to be fully functional for a period of 60 months from the date of original shipment, given correct customer installation and regular maintenance. PairGain will repair or replace any unit without cost during this period if the unit is found to be defective for any reason other than abuse or incorrect use or installation.

Do not try to repair the unit. If it fails, replace it with another unit and return the faulty unit to PairGain for repair. Any modifications of the unit by anyone other than an authorized PairGain representative voids the warranty.

If a unit needs repair, call PairGain for a Return Material Authorization (RMA) number and return the defective unit, freight prepaid, along with a brief description of the problem, to:

PairGain Technologies, Inc.
14352 Franklin Avenue
Tustin, CA 92780
ATTN: Repair and Return Dept.
(800) 638-0031

PairGain continues to repair faulty modules beyond the warranty program at a nominal charge. Contact your PairGain sales representative for details and pricing.

COMPLIANCE

The shelf, enclosure, and desktop units within the PairGain HiGain-ETSI product line have been affixed with the CE Mark. This is based on compliance of the complete PairGain HiGain-ETSI product line with directive 89/336/EEC as amended by directive 93/68/EEC.

Corporate Office

14402 Franklin Avenue
Tustin, CA 92780

Tel: (714) 832-9922

Fax: (714) 832-9924

For Technical Assistance:

(800) 638-0031

