

## QUICK INSTALLATION



## HDU-409 LIST 1 AND LIST 2 DOUBLER UNIT

---

## THE HDU-409 LIST 1 AND LIST 2

The HiGain® HDU-409 List 1 and List 2 are low-power micro doubler units that extend the range of a HiGain repeaterless T1 transmission system. The doubler units are installed between any doubler-compatible HiGain Line Unit (HLU), HiGain Doubler Unit (HDU), or HiGain Remote Unit (HRU). Each doubler allows 1.544 Mbps transmission over an additional Carrier Service Area (CSA) range.

The HDU-409 List 1 is only compatible with the HiGain product line. The HDU-409 List 2 is compatible with both the HiGain and PG-Flex product lines. The CSA includes loops up to 12,000 feet (3.657 km) of 24 AWG or 9,000 feet (2.743 km) of 26 AWG wire.

### FEATURES

- 
- Occupies one 239 T1 mechanics slot
  - Powered by any doubler-compatible HiGain or PG-Flex (List 2 only) line unit
  - Extremely low power dissipation
  - Lightning and power cross-protection on both sides of the High-bit-rate Digital Subscriber Line (HDSL) interface
  - Front-panel status display Light Emitting Diode (LED)
  - Extremely low latency
  - Compatible with PG-Flex List 3x line units in configurations with up to three spans
  - Minimal wander and jitter
  - Used in four-span line-powered HiGain circuits (three doublers and one remote) or five-span locally powered circuits (four doublers and one remote)
- 

### SPECIFICATIONS

---

<b>Operating Temperature</b>	-40 °F (-40 °C) to +149 °F (+65 °C)
<b>Operating Humidity</b>	5% to 95% non-condensing
<b>Operating Temperature in Outside Enclosures</b>	Complies with Section 10.2.1.3 of TA-NWT-001210
<b>Operating Elevation</b>	200 feet (60.96 m) below sea level to 13,000 feet (3.96 km) above sea level
<b>Mounting</b>	Single 239 T1 mechanics slot
<b>HDSL Line Code</b>	784 kbps, Two Binary, One Quaternary (2B1Q) full duplex
<b>HDSL Output</b>	+13.0 dBm, 135 Ω
<b>Maximum Provisioning Loss</b>	35 dB at 196 KHz, 135 Ω
<b>Line Clock Rate</b>	Internal Stratum 4 clock
<b>Power Consumption</b>	3.0 W (nominal)
<b>Resistive Signature Input/Output</b>	5 Ω (typical)

---

# 1

## BEFORE YOU BEGIN

- 1 Verify that you are installing the HDU-409 with the following compatible HiGain outdoor enclosures. For a list of compatible non-ADC enclosures, see the HDU-409 List 1 and List 2 technical practice, section number 150-409-100-xx.
  - HRE-458, 10-slot unit
  - HRE-500, 1-slot unit
  - HRE-504, 4-slot unit
  - HRE-506, 6-slot unit
  - HRE-712, 12-slot unit
  - HRE-602, 2-slot unit
  - HRE-819, 12-slot unit
- 2 Verify that you are installing the HDU-409 with compatible line and remote circuit modules (see [Table 1](#) inside).
- 3 Determine the number of doublers the circuit can support based upon:
  - the model of the HLU and HRU in the circuit (see [Table 1](#))
  - whether the HRU is locally powered or line-powered (see [Table 1](#))
  - whether you are installing in a HiGain (see “[HiGain Doubler Applications](#)”) or PG-Flex application (see “[PG-Flex Doubler Applications](#)”).
- 4 Observe the following deployment rules for enclosure placement:
  - Rule 1: Place the enclosures at the electrical limits (35 dB) of each span.
  - Rule 2: Make all spans the same electrical length (same 196 kHz loss) to achieve optimum performance if Rule 1 is not applicable.
  - Rule 3: To minimize power consumption and dissipation of the HLU, confirm that the spans closest to the HLU are as short as possible and the spans furthest from the HLU are as long as possible.
- 5 Determine the enclosure model based upon doubler and repeater capacities of occupied slots as shown in [Table 2 “Outdoor Enclosure Capacities with Full Solar Load”](#).

*Continued* 

## Card-edge connector

1	Ground
2	DC (in) test
3	HDSL Ring A (out)
4	HDSL Tip A (out)
5	HDSL Tip A (in)
6	HDSL Ring A (in)
7	DC (out) test
8	HDSL Tip B (in)
9	HDSL Ring B (in)
10	Ground
11	HDSL Ring B (out)
12	HDSL Tip B (out)

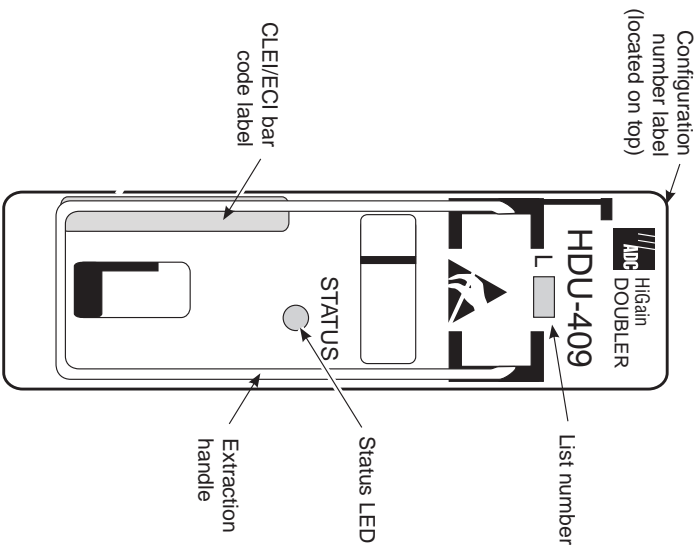

Status LED reports the following conditions:

Flashing red (once per second)	Indicates HDSL Cyclic Redundancy Check (CRC) error has occurred between the HDU-409 and the upstream module.
Flashing red (twice per second)	Indicates HDSL CRC error has occurred between the HDU-409 and the downstream module.
Flashing yellow (once per second)	Indicates a loopback at the doubler towards the network. This loopback tests the integrity of the upstream span(s).
Flashing yellow (twice per second)	Indicates a loopback at the doubler towards the customer. This loopback tests the integrity of the downstream span(s).
Flashing green (once per second)	Indicates synchronization is being attempted between the HDU-409 and the upstream module.
Flashing green (twice per second)	Indicates synchronization is being attempted between the HDU-409 and the downstream module.
Solid yellow	Indicates the HDSL margin is less than the margin threshold provisioned for the circuit.
Solid green	Indicates HDSL frame synchronization has been achieved between the HDU-409 and both the upstream and downstream modules.

# HIGAIN DOUBLER APPLICATIONS

The HDU-409 List 1 and List 2 can be used in two- to five-span circuits, depending on the HLU model and the power option (line or local) of the compatible HRU. [Table 1](#) lists the maximum number of doublers that can be deployed.

**Table 1.** Maximum Number of HDU-409 Doublers per Circuit

HLU Model	Maximum Number of HDU-409 Doublers Per Circuit <sup>(a)</sup>			
	Line-Powered Remote		Locally Powered Remote	
	I-CPE ON	I-CPE OFF	I-CPE ON	I-CPE OFF
HLU-231 List 3D, List 6D, List 7x HLU-232 List 1D HLU-319 List 2x HLU-388 List 2x, HLU-431 List 1D	1	2	2	2
HLU-231 List 8x HLU-319 List 5x HLU-388 List 5x	2	3 <sup>(b)</sup>	2	4 <sup>(c)</sup>

- (a) The HRU-412 is limited to applications with one and two doublers only.
- (b) Requires HRU-402, all lists.
- (c) Requires HRU-402 List 1 or List 3.



**HiGain systems support doubler loopbacks when HiGain doublers are used with compatible HiGain circuit modules.**  
**Consult your line unit documentation for details on how to execute generic or special doubler loopbacks.**

# PG-FLEX DOUBLER APPLICATIONS

[Figure 1](#) shows a typical HDU-409 List 2 installation for the PG-Flex subscriber carrier system. For each doubler installed between the PG-Flex Central Office Terminal (COT) and Remote Terminal (RT), two auxiliary power pairs are required. A maximum of two doublers may be installed in a PG-Flex system. With two doublers, four sets of auxiliary power pairs must be installed between the COT and the RT. These auxiliary power pairs must be the same wire gauge (or lower) as those assigned to the HDSL pairs.

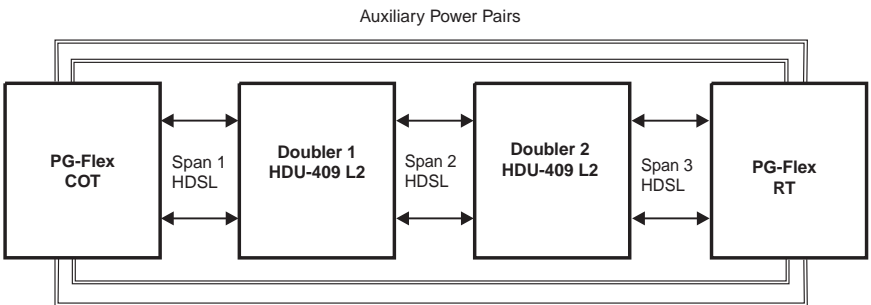

**Figure 1.** Typical HDU Installation with PG-Flex



**PG-Flex systems do not support doubler loopbacks.**

# DOUBLER DEPLOYMENT

Sealed multislot outdoor enclosures restrict the rate of heat transfer to the outside air. This restriction may result in excessive heat buildup. [Table 2](#) shows the doubler and repeater capacities of occupied slots that can be reliably housed in compatible HiGain outdoor enclosures as a function of solar exposure and maximum ambient temperature. (For a list of compatible non-ADC enclosures, see the HDU-409 List 1 and List 2 technical practice, section number 150-409-100-xx.)

The capacities shown in [Table 2](#) can be increased to all odd or even slots (where applicable) for non-solar load (shaded or manhole applications). For every four T1 repeaters that are installed with the doublers, the outdoor capacity must be decreased by one doubler or repeater unit. In addition to the T1 repeaters, the HiGain HDU-439 mini doubler can also be installed along with the HDU-409 micro doubler in the same enclosure.

*Table 2. Outdoor Enclosure Capacities with Full Solar Load<sup>(a)</sup>*

Enclosure Model	Description	HDU-409 Doubler Capacity <sup>(b)</sup>	239 T1 Repeater Capacity <sup>(b)</sup>	Recommended Slot Assignment for Maximum Capacity <sup>(c)</sup>
HRE-458	Outdoor canister, pole or wall mount, with Universal Card Cage	10	10	1-10
HRE-500	Outdoor canister, pole or wall mount, with Universal Card Cage	1	1	1
HRE-504	Outdoor canister, pole or wall mount, with Universal Card Cage	4	4	1-4
HRE-506	Outdoor canister, pole or wall mount, with Universal Card Cage	6	6	1-6
HRE-602	Outdoor canister, pole or wall mount, with Universal Card Cage	2	2	1 and 2
HRE-712	Outdoor canister, pole mount (List 1), wall mount (List 2), with Universal Card Cage	12	12	1-12
HRE-819	Outdoor dual chamber, pole or wall mount	12	12	1-12
AT&T-819	Outdoor dual chamber pole and wall mount	14	25	1, 3, 5, 7, 8, 10, 12, 14, 15, 17, 19, 21, 23, 25

(a) Maximum sunlight exposure per TR-TSY-000057.

(b) Decrease capacities by five-percent (round up) for every 5 °F increase above maximum ambient temperature. Increase capacities by five percent (round down) for every full 5 °F decrease below maximum ambient temperature.

(c) Refer to the applicable technical practice for full deployment details.

## 2 INSTALLATION

- 1 Align the HDU-409 with the enclosure slot guides and slide the unit in.
- 2 Push the unit into the enclosure until it snaps into place, indicating that it is properly seated.



**The HDU has a Ground Fault Detection (GFD) circuit as described in R7-1, Section 7.2.1 of GR-1089 CORE, Issue 1, Revision 1, December 1996.**

**When used in a HiGain circuit, the HDU-409 immediately detects ground faults occurring in the span on either side of the interrupted circuit (doubler) and shuts down the HDSL power feed circuit until the ground fault is located and repaired. When using older doublers without a GFD circuit, the HDU-409 must be the doubler nearest the HLU to support GFD. The ground plane of the doubler enclosure must be securely connected to earth ground.**

## 3 POWER-UP SEQUENCE

Once the HDU-409 is installed in the enclosure, the front panel Status LED flashes green when power is applied from an upstream unit. Once the loops on both sides of the HDU synchronize, the LED turns a steady green.

## FCC Class A Compliance

This equipment has been tested and found to comply with the limits for a Class A digital device, pursuant to Part 15 of the FCC Rules. These limits are designed to provide reasonable protection against harmful interference when the equipment is operated in a commercial environment. This equipment generates, uses, and can radiate radio frequency energy and, if not installed and used in accordance with the instruction manual, may cause harmful interference to radio communications. Operation of this equipment in a residential area is likely to cause harmful interference in which case the user will be required to correct the interference at his own expense.

## Limited Warranty

Product warranty is determined by your service agreement. Contact your sales representative or Customer Service for details.

## Modifications

Any changes or modifications made to this device that are not expressly approved by ADC DSL Systems, Inc. voids the user's warranty.

All wiring external to the products should follow the provisions of the current edition of the National Electrical Code.

## Standards Compliance

This equipment has been tested and verified to comply with the applicable sections of the following safety standards:

- GR 63-CORE - Network Equipment-Building System (NEBS) Requirements
- GR 1089-CORE - Electromagnetic Compatibility and Electrical Safety
- Binational standard, UL-1950/CSA-C22.2 No. 950-95: Safety of Information Technology Equipment

## Trademark Information

ADC is a registered trademark of ADC Telecommunications, Inc. HiGain is a registered trademark of ADC DSL Systems, Inc. Other product names mentioned in this installation guide are used for identification purposes only and may be trademarks or registered trademarks of their respective companies.

## Copyright Information

© 2002 ADC DSL Systems, Inc. All rights reserved. Information contained in this document is company private to ADC DSL Systems, Inc., and shall not be modified, used, copied, reproduced or disclosed in whole or in part without the written consent of ADC.

## ADC DSL Systems, Inc.

14402 Franklin Avenue  
Tustin, CA 92780-7013  
Tel: 714.832.9922  
Fax: 714.832.9924

## Technical Assistance

Tel: 800.638.0031  
Tel: 714.730.3222  
Fax: 714.730.2400



Product Catalog: HDU-409-L1, HDU-409-L2  
CLEI: T1R6AE0C, T1R6AEDC  
Document: 350-409-100-02, Issue 2



1213936

October 13, 2000