

HiGain

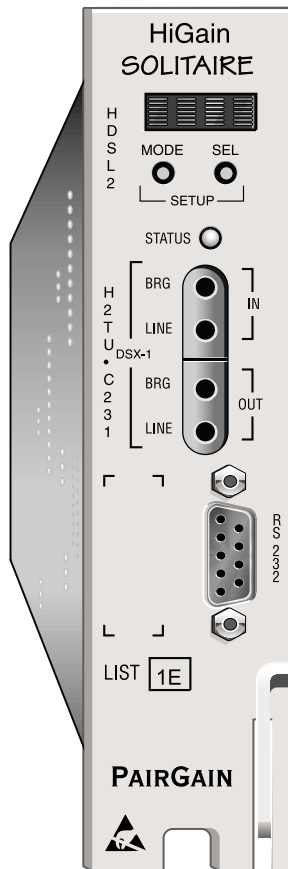

HiGain HDSL2 Line Unit

H2TU-C-231 List 1E

Part Number: 150-2404-15

CLEI Code: VACH4VYC

Revision History of This Practice

Revision	Release Date	Revisions Made
01	November 29, 1999	Initial release.
02	April 21, 2000	Firmware update.
03	January 08, 2002	ADC rebranding

Copyright

April 21, 2000

© 2000 ADC DSL Systems, Inc. All rights reserved.

Trademark Information

ADC is a registered trademark of ADC Telecommunications, Inc. HiGain is a registered trademark of ADC DSL Systems, Inc. No right, license, or interest to such trademarks is granted hereunder, and you agree that no such right, license, or interest shall be asserted by you with respect to such trademark. Other product names mentioned in this practice are used for identification purposes only and may be trademarks or registered trademarks of their respective companies.

Disclaimer of Liability

Information contained in this document is company private to ADC DSL Systems, Inc., and shall not be modified, used, copied, reproduced or disclosed in whole or in part without the written consent of ADC.

Contents herein are current as of the date of publication. ADC reserves the right to change the contents without prior notice. In no event shall ADC be liable for any damages resulting from loss of data, loss of use, or loss of profits, and ADC further disclaims any and all liability for indirect, incidental, special, consequential or other similar damages. This disclaimer of liability applies to all products, publications and services during and after the warranty period.

USING THIS TECHNICAL PRACTICE

The following conventions are used in this manual:

- Monospace type indicates screen text.
- Keys you press are indicated by small icons such as **Y** or **ENTER**. Key combinations to be pressed simultaneously are indicated with a plus sign as follows: **CTRL** + **ESC**.
- Items you select are in **bold**.
- Three types of messages, identified by icons, appear in text.



Notes contain information about special circumstances.



Cautions indicate the possibility of equipment damage or personal injury.



The Electrostatic Discharge (ESD) susceptibility symbol indicates that a device or assembly is susceptible to damage from electrostatic discharge.

For a list of abbreviations used in this document, refer to [“Appendix E - Abbreviations”](#) on page 67.

DOCUMENTATION

If you have comments on this PairGain document, send an email to technical_publications@pairgain.com. Type the product name and the section number of the document in the subject area of the email message.

INSPECTING SHIPMENT

Upon receipt of the equipment:

- Unpack each container and inspect the contents for signs of damage. If the equipment has been damaged in transit, immediately report the extent of damage to the transportation company and to PairGain. Order replacement equipment, if necessary.
- Check the packing list to ensure complete and accurate shipment of each listed item. If the shipment is short or irregular, contact PairGain as described in the Warranty located inside the back cover. If you must store the equipment for a prolonged period, store the equipment in its original container.

TABLE OF CONTENTS

Overview	1
Features	1
Compatibility	2
Applications	2
HiGain Regenerators.....	3
Front Panel	4
Installation	9
Verification	10
Verification without a Downstream Device	10
Verification with a Downstream Device	10
Provisioning Requirements	11
Provisioning	12
Using the MODE and SEL Buttons	12
Setting Options through MODE and SEL	12
Resetting to Factory Default Values.....	13
Displaying System Parameter Settings.....	13
Disabling an Alarm.....	13
Loopback Modes	13
Using a Maintenance Terminal	14
Connecting to a Maintenance Terminal.....	14
The Logon Screen.....	14
Provisioning Tasks.....	16
Setting Date and Time	16
Setting Circuit ID Numbers	17
Making Changes to the System Configuration.....	18
Clearing the History, Alarm, and Event Log Screens	30
Monitoring System Activity and Performance	31
System Overview	31
Using the Monitor Screen to View System Activity.....	32
Using the Performance Screens to View Performance Data.....	34
Performance History at the DS1 Interface.....	35
Performance History at the HDSL2 Interface	37
Current Statistics Screens for the DS1 Interface	38
Current Statistics for HDSL2 Interface	39
Using the Performance Screens to View Alarm Data.....	40
Alarm History at the DS1 Interface	40

Alarm History at the HDSL2 Interface	42
Using the Event Log to Track System Events	43
Testing	45
Front-Panel System Alarms	45
Alarm Option for Digital Loop Carrier (DLC) Feed	46
Retiring System Alarms	46
Remote LOS and AIS Response	47
OCT55 Test Pattern with AMI Code	47
Loopback Operation	48
Generic Loopback Commands	48
Special Loopback Commands	50
Manual Loopback Session	51
Loopback Test Procedures	52
General Troubleshooting Tips	52
GNLB Test Procedures	52
A2LB Test Procedures	54
A3LB and A4LB Test Procedures	57
Appendix A - Specifications	58
Power Consumption	59
Maximum Power Dissipation	59
Maximum Current Drain	59
H2TU-C-231 List 1E Card Connector	60
Network Management Control Bus	60
Fuse Alarm	61
System Alarm Output Pins	61
Craft Port	61
Appendix B - Functional Operation	62
Timing	63
Ground Fault Detect	63
Appendix C - Compatibility	64
Appendix D - Product Support	65
Appendix E - Abbreviations	67
Certification and Warranty	Inside Back Cover
Limited Warranty	69

LIST OF FIGURES

1. HDSL2 System Model	3
2. H2TU-C-231 List 1E Front Panel.....	4
3. Installing the H2TU-C-231List 1E into a Shelf	9
4. Logon Screen	15
5. Configuration Menu - Date and Time.....	16
6. Inventory Screen	17
7. Configuration Menu.....	18
8. Configuration Menu - Standard Options (Defaults Shown)	19
9. Configuration Menu - PairGain Options (Defaults Shown)	19
10. Configuration Menu - Reset to Factory Defaults.....	29
11. Master Clear.....	30
12. System Spans	31
13. Monitor Screen - Active Loopback with Alarms.....	32
14. H2TU-R DS1 31-day Performance History.....	35
15. H2TU-C DS1 25-hour Performance History	35
16. H2TU-C HDSL2 31-day Performance History	37
17. H2TU-R DS1 Current Statistics.....	38
18. H2TU-C DS1 Current Statistics.....	38
19. H2TU-C HDSL2 Current Statistics	39
20. H2TU-C DS1 Alarm History Screen	40
21. H2TU-R DS1 Alarm History Screen	41
22. H2TU-C HDSL2 Alarm History Screen	42
23. System Event Log	43
24. H2TU-R LOS and AIS Response Priorities.....	47
25. Loopback Summary	48
26. Loopback Modes.....	53
27. H2TU-C-231 List 1E Card-edge Connector	60
28. RS-232 Craft Port Pinouts.....	61
29. H2TU-C-231 List 1E Block Diagram.....	62

LIST OF TABLES

1. Front-panel Description.....	5
2. Front-panel Display Messages	6
3. Navigational Keys for the HiGain HDSL2 Maintenance Terminal Screens.....	14
4. Logon Screen Menus.....	15
5. H2TU-C-231 List 1E Standard Config Screen Options	20
6. H2TU-C-231 List 1E PairGain Config Screen Options	21
7. DS1/DSX-1 24-hour PM Threshold.....	23
8. Response to H2TU-R DS1 Frame Conversion Options	24
9. Extended SuperFrame Format.....	25
10. SuperFrame Format	26
11. DDS NI and DS0 DP Latching Loopback Sequence	26
12. HiGain HDSL2 Loopback vs. Latching Sequence.....	27
13. Response of H2TU-C and H2TU-R to LOS and AIS	28
14. Monitor Screen Descriptions.....	33
15. Error Acronyms Used on the DS1 Performance History Screens.....	36
16. Error Acronyms Used on the HDSL2 Performance History Screens	37
17. DS1 Alarm Descriptions	41
18. HDSL2 Alarm Descriptions	42
19. Event Log Entry Messages List.....	44
20. Front-Panel System Alarms Summary	45
21. Summary of HiGain HDSL2 Loopback Codes and Activation Methods	49
22. Addressable Repeater Loopback Commands (A2LB)	54
23. Addressable Repeater Loopback Commands (A3LB and A4LB)	57
24. H2TU-C Power Parameters—No Regenerator	59

OVERVIEW

The HiGain HDSL2 product family from ADC® is the industry's first practical implementation of High-bit-rate Digital Subscriber Line 2 (HDSL2). ADC products are fully compliant with the HDSL2 standard. Providing full-rate T1 access using just a single copper pair, HDSL2 is a cost-effective solution that offers an open architecture. The open architecture inherent in HDSL2 guarantees interoperability, allowing simple, economic accommodation of network growth. HiGain HDSL2 uses the industry's first HDSL2 chipset (ANSI T1/E1.4 compliant) developed by ADC.

HiGain HDSL2 products provide 1.552 Mbps transmission on one unconditioned copper pair over the full Carrier Service Area (CSA) range. The CSA includes loops up to 12,000 feet of 24 American Wire Gauge (AWG) wire or 9,000 feet of 26 AWG wire, including bridged taps.

FEATURES

The H2TU-C-231 List 1E line unit is the Central Office (CO) side of a T1 transmission system.

- HDSL2 transmission features
 - Three-span range with two regenerators (36 kft, 24 AWG)
 - Lightning and power cross-protection on HDSL2 interfaces
 - Full duplex HDSL2 transmission on one pair at 1.552 Mbps
 - Ultra-low wander (Stratum 1 compliant)
 - Grounded loop detection on High-bit-rate Digital Subscriber Line 2 (HDSL2)
- Front-panel provisioning features
 - Four-character status display
 - DS1 splitting and bridging access
 - Status LED
 - RS-232 craft port for connection to a maintenance terminal
- HiGain HDSL2 maintenance screens for inventory, provisioning, and troubleshooting
 - High-performance, non-volatile performance monitoring
 - Non-volatile alarm histories
 - Performance Report Messaging (PRM) support for Supplemental PRM (SPRM) and Network PRM (NPRM) at the H2TU-R
- Configuration options
 - Selectable DS1 pre-equalizer
 - Bipolar Violation Transparency (BPVT)
 - Bit Error Rate (BER) alarm
 - Loss of Signal/Alarm Indication Signal (LOS/AIS) payload alarm
 - Remote provisioning
 - Selectable loopback activation codes
- Compatible with Small Cross-section Shelf (SXSS) and equipment
- Digital Data Service (DDS) latching loopback

- Payload (PL) and HiGain (HG) loopback source identification
- Network Management and Administration (NMA) interface
- Margin Alarm (MAL) threshold

COMPATIBILITY

The H2TU-C-231 is designed to mount in 220 mechanics shelves. For a list of compatible shelves see “Appendix C - Compatibility” on page 64.

APPLICATIONS

HiGain HDSL2 systems provide a cost-effective, easy-to-deploy method for delivering T1 High Capacity Digital Service (HCDS) over a single copper pair. HiGain HDSL2 systems support a multitude of network connections and system models (see [Figure 1 on page 3](#)).

- The service is deployed over one unconditioned, non-loaded copper pair.
- Conventional, inline, T1 repeaters are no longer required.
- Cable pair conditioning, pair separation, and bridged tap removal are not required.

Each loop has no more than 35 dB of loss at 196 kHz, with driving and terminating impedances of 135 Ω . In general, HiGain HDSL2 systems:

- Operate effectively in the same cable binder group with other HDSL2 lines, HDSL, T1, ADSL, SDSL, POTS, DDS, and other transmission schemes.
- Can be used with customers requiring DS1 service on a temporary or permanent basis.
- Provide a means of quickly deploying service in advance of fiber-optic transmission systems.



DS1 is used throughout this document to refer to either the remote unit's DS1 interface or the line unit's DSX-1 interface.

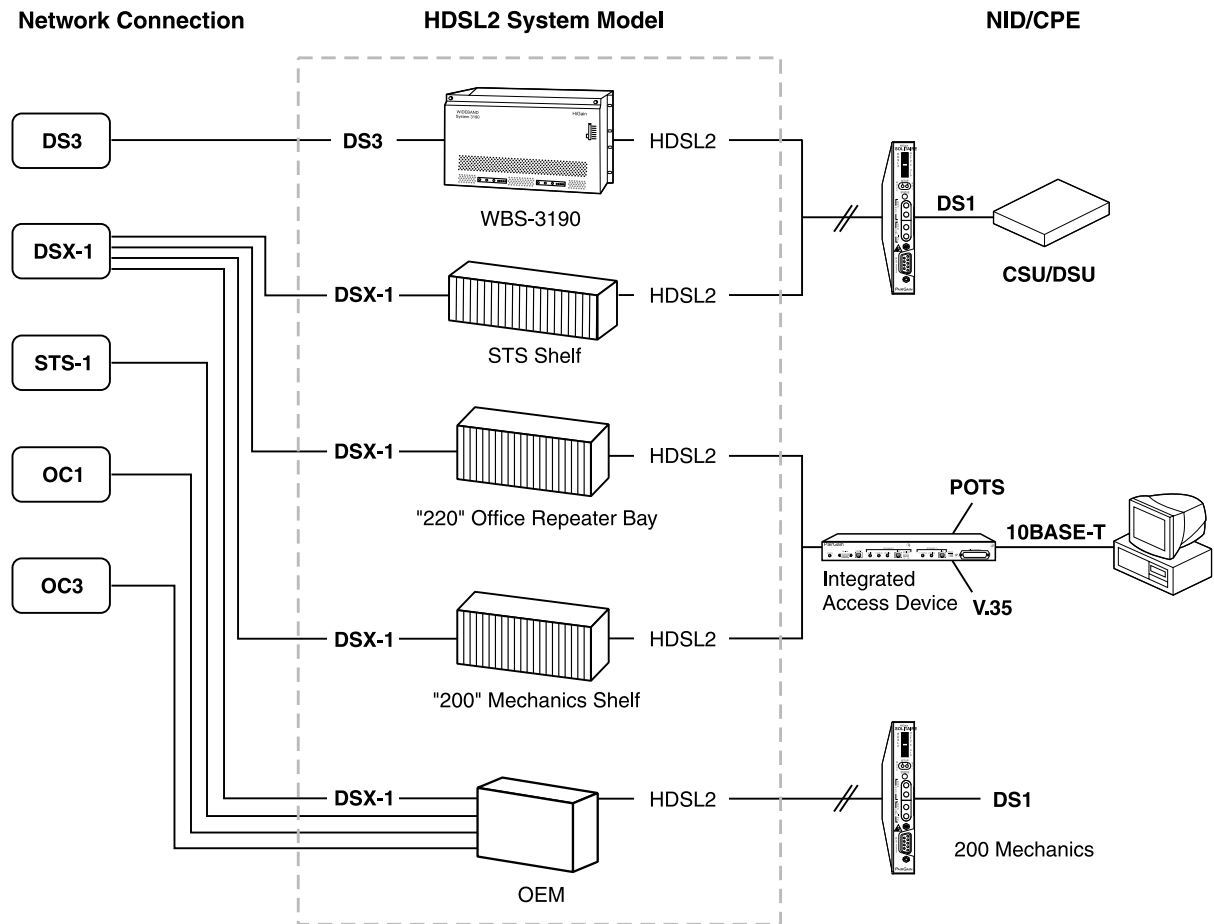

Figure 1. HDSL2 System Model

HIGAIN REGENERATORS

For applications without regenerators (doublers), the H2TU-C-231 is directly connected to an H2TU-R remote unit by one HDSL2 cable pair. The H2TU-C-231 List 1E is compatible with all HiGain H2TU-Rs.

For applications with regenerators, one to two regenerators may be used in the HDSL2 loop between the H2TU-C and H2TU-R.

- The H2TU-C-231 List 1E can power one regenerator (H2RU-407 or H2RU-409) and a remote unit (H2TU-R-402) for a total of two spans.
- If the H2TU-R is locally powered, the H2TU-C can power up to two regenerators for a total of three spans.



Future product enhancements of the H2TU-C-231 will support regenerators.

FRONT PANEL

Figure 2 shows the H2TU-C-231 List 1E front panel. Table 1 on page 5 describes the front-panel components. For pinout diagrams of the H2TU-C card-edge connector and craft port, refer to “Appendix A - Specifications” on page 58.

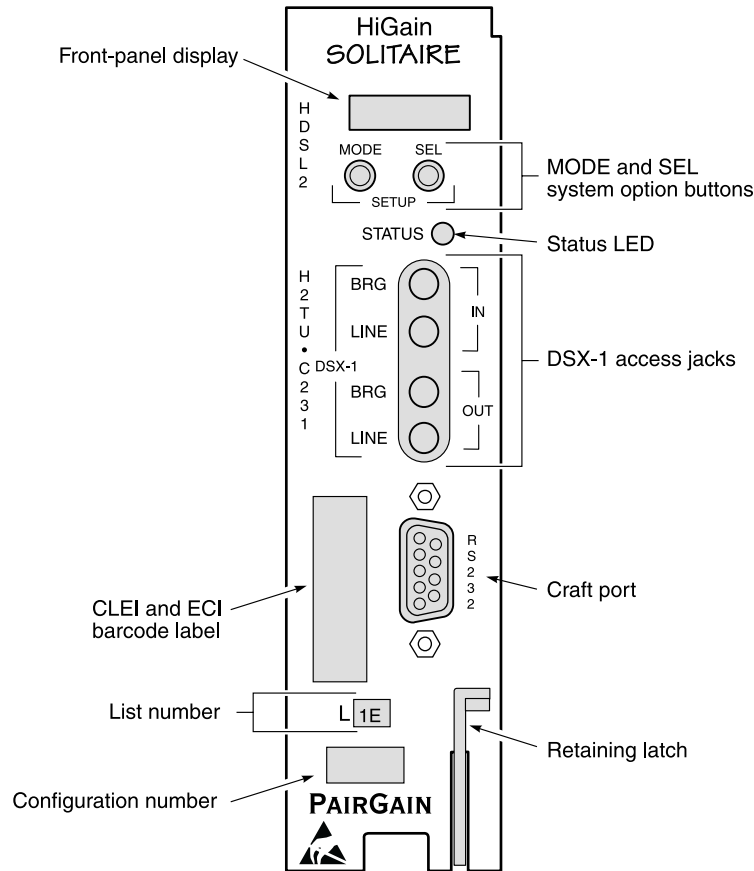

Figure 2. H2TU-C-231 List 1E Front Panel

Table 1. Front-panel Description

Front-panel Feature	Function
Front-panel display	Displays four-character status, provisioning, and alarm system messages. The front-panel display illuminates when power is initially applied. To conserve power, the display only remains on for 5 minutes. Using the MODE or SEL buttons reactivates the display and restarts the 5-minute timer. Refer to Table 2 on page 6 for a listing of the four-character messages.
MODE and SEL system option buttons	Permits the user options to be monitored and modified without the need of a maintenance terminal. Used to initiate all HiGain HDSL2 loopbacks and to display DSX-1 line parameters and line unit identity.
Status LED	The status LED can report the following conditions:
Off	Line power is off.
Green	Normal operation.
Red	Fuse alarm.
Flashing red	HDSL2 acquisition and system alarm.
Yellow	An H2TU-C-231 Customer Remote Loopback (CREM) or a Network Local Loopback (NLOC) is in effect.
Flashing yellow	H2TU-C-231 is in an Armed (ARM) state.
DSX-1 access jacks	
BRG	Provides non-intrusive bridging jack access to (IN) and from (OUT) the HDSL2 span at the DSX-1 interface. Allows the two DS1 payloads to be monitored.
LINE	Provides splitting jack access to (IN) and from (OUT) the HDSL2 span at the DSX-1 interface. Breaks the IN and OUT paths to permit test signal insertion and retrieval.
Craft port (RS-232)	Provides bidirectional communication between the unit and an external terminal to allow configuration and performance monitoring through the maintenance terminal screens.
CLEI and ECI bar code label	Provides the human-readable Common Language Equipment Identifier (CLEI) code number and the Equipment Catalog Item (ECI) bar code number.
List number	Identifies the list number of the H2TU-C-231.
Retaining latch	Retains the card in the shelf when pulled up and extracts the card from the shelf when pulled down.
Configuration number	<p>For some products the configuration number may contain either a five- or six-digit warranty configuration number or a stand-alone two or three-digit configuration number as follows:</p> <ul style="list-style-type: none"> Digit 1 - Last digit of shipment year Digits 2 and 3 - Shipment month Digits 4, 5, and 6 - Configuration number <p>The configuration number identifies the version of the product. New configuration numbers usually accompany changes in the last two characters of the CLEI code.</p> <p>The configuration number is found on a small label attached to the front panel. It is the last two numbers (following the x) of a 13-character part number. For example: 150-1234-01-x01.</p>

Table 2 lists the front-panel display messages. The three- or four-character display reports the code of a pertinent alarm, loopback, or diagnostic message and, in some cases, is followed by a second four-character message that modifies the first message with a value or current configuration setting.

Table 2. *Front-panel Display Messages*

Message	Full Name	Description
ALARM MESSAGES		
ACO	Alarm CutOff	A system alarm has occurred and has been retired to an ACO condition by pressing the SEL button on the H2TU-C front panel.
ALRM	Alarm Condition Exists	A system alarm condition is in effect.
DBER	DS1 Bit Error Rate	A system DS1 BER alarm is in effect and remains in effect until cleared.
HBER	HDSL2 Block Error Rate	A system HDSL2 Block Error Rate alarm is in effect.
LA	Loop Attenuation	Indicates that the attenuation on the HDSL2 loop has exceeded the maximum threshold value.
LAIS	Local Alarm Indication Signal	Indicates an AIS (all ones) pattern is being transmitted from the local DS1 output port.
LLOS	Local Loss of Signal	Indicates that no signal is detected at the DSX-1 input to the H2TU-C. Causes a system alarm.
LOSW	Loss of Sync Word	Indicates that the HDSL2 loop has lost synchronization.
MAL	Margin Alarm	The margin on HDSL2 loop has dropped below the threshold (0 to 15 dB) as set by the operator.
PWR FEED GND	Ground	The HDSL2 loop is grounded.
PWR FEED OPEN	Open	Indicates a line power open condition.
PWR FEED SHRT	Short	Indicates a short between the Tip and Ring of the HDSL2 pair.
PRMF	Performance Report Messaging - Far End	H2TU-R PRM-FE BER threshold has been exceeded.
PRMN	Performance Report Messaging - Near End	H2TU-R PRM-NE BER threshold has been exceeded.
RAIS	Remote Alarm Indication Signal	Indicates an AIS (all ones) pattern is being received at the H2TU-R DS1 input port.
RLOS	Remote Loss of Signal	Indicates that no signal is detected at the DS1 input to the H2TU-R. Causes a system alarm.
RRAI	Remote RAI—Remote Alarm Indication at the H2TU-R	Indicates an RAI alarm (yellow) from the CPE with errors from the line unit or network.
SPN <i>n</i>	Span Number	Accompanies the LOSW alarm and identifies the span where the LOSW alarm occurred.
TRCI	Transmit RAI-CI—Remote Alarm Indication at the H2TU-R	Upon reception of an RAI (yellow alarm) from the CPE, the H2TU-R sends RAI-CI towards the network if the network signal received at the H2TU-R is clear. If the network signal is impaired (LOS, AIS, or LOF), then the RAI is passed on to the network unaltered.
TUC	Transmission Unit Central Office	Accompanies the HBER, MAL, and LA alarm and indicates that the alarm has occurred at the H2TU-C central office unit.
TUR	Transmission Unit Remote End	Accompanies the HBER, MAL, and LA alarm and indicates that the alarm has occurred at the H2TU-R remote unit.

Table 2. Front-panel Display Messages (Cont.)

Message	Full Name	Description
LOOPBACK MESSAGES		
CRG n	Customer Regenerator n Loopback	Signal from customer is looped back to the customer at H2RU n , where n is the number of the regenerator.
CLOC	Customer Local Loopback	Signal from customer is looped back to the customer at the H2TU-R.
CREM	Customer Remote Loopback	Signal from customer is looped back to the customer at H2TU-C-231.
NRG n	Network Regenerator n Loopback	DSX-1 signal is looped back to the network at H2RU n , where n is the number of the regenerator.
NLOC	Network Local Loopback	DSX-1 signal is looped back to the network at the H2TU-C.
NREM	Network Remote Loopback	DSX-1 signal is looped back to the network at the H2TU-R.
SMJK	Remote SmartJack Loopback	DSX-1 signal is looped back to the network at the H2TU-R SmartJack module.
DIAGNOSTIC MESSAGES		
A = xx	Maximum Loop Attenuation	The Attenuation (A) message appears followed by xx , where xx is the loop attenuation of the longest (maximum loss) span measured in dB.
ACQ	Acquisition	The multiplexers of the H2TU-C and H2TU-R (or the H2TU-C and first regenerator) are trying to establish synchronization over the HDSL2 loop of Span 1.
A n L	Acquisition n Loop	The multiplexers of the two devices on Span n are trying to establish synchronization with each other, where n is the number of the span.
ARM	HiGain System Armed	Armed to respond to Intelligent Repeater Loop (ILR) codes.
BAD RT?	No Response from H2TU-R	The H2TU-C does not receive any response from the H2TU-R. Therefore, the integrity of the H2TU-R or the HDSL2 loop is questionable.
FERR	Framing Bit Error Occurred	Framing bit error occurred at H2TU-C DSX-1 input.
FLDL	Flash Download	Flash download of firmware updates. Contact Customer Service for update procedures (see "Appendix D - Product Support" on page 65.)
HES	HDSL2 CRC Error	H2TU-C HDSL2 Loop Cyclical Redundancy Check (CRC) error.
LBPV	Local Bipolar Violation	A bipolar violation has been received at the DSX-1 input to the H2TU-C-231.
M= xx	HDSL2 Loop Margin	Indicates the power of the received HDSL2 signal relative to noise (S/N with respect to 21.5 dB). Any value of 6 dB or greater is adequate for reliable system operation.
MNGD	Managed	The H2TU-C-231 is under control of the H2TU-319 network management unit. In this state, the front-panel craft port and push buttons are disabled.
PWR FEED OFF	Power Feed Off	HDSL2 span power has been turned off by setting the PWFD option to OFF, or HDSL2 span power has been turned off by use of the A2LB Intelligent Office Repeater (IOR) powerdown code.
PWR FEED ON	Power Feed On	Indicates that the HDSL2 loop is not grounded or shorted.
SIG	Signaling	The transceivers of the H2TU-C and H2TU-R (or the H2TU-C and first regenerator) are trying to establish contact with each other over the HDSL2 loop of Span 1.

Table 2. *Front-panel Display Messages (Cont.)*

Message	Full Name	Description
S_nL	Synchronization n Loop	The transceivers of the two devices on Span n are trying to establish contact with each other, where n is the number of the span.
SYSTEM INFORMATION MESSAGES ^(a)		
CODE $xxxx$	Line Code: AMI, B8ZS	The DS1 line code setting: Alternate Mark Inversion (AMI) or Bipolar with 8-Zero Substitution (B8ZS).
FRM $xxxx$	Frame: SF, ESF, UNFR	Defines the type of frame pattern being received from the DSX-1: SuperFrame (SF), Extended SuperFrame (ESF), or Unframed (UNFR).
LATT xx	Loop Attenuation	The current loop attenuation threshold setting is measured in dB.
LIST xx	H2TU-C-231 List Number	The list number xx .
MARG xx	Margin	The current margin threshold setting is measured in dB.
VER $x.xx$	H2TU-C-231 Software Version Number	The software version number $x.xx$.
(a) System information messages are displayed in Scroll Mode. To scroll through the messages, press the MODE and SEL buttons for 3 or more seconds.		

INSTALLATION



Upon receipt of the equipment, inspect the contents for signs of damage. If the equipment has been damaged in transit, immediately report the extent of damage to the transportation company and to ADC.

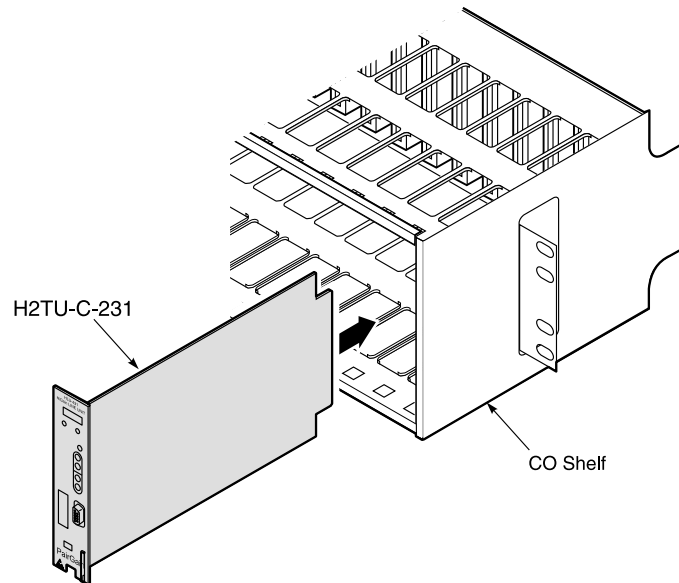

Figure 3. Installing the H2TU-C-231 List 1E into a Shelf



When installing an H2TU-C in a chassis, be sure to wear an antistatic wrist strap. Avoid touching components on the circuit board.



To comply with the intrabuilding wiring requirements of GR-1089 CORE, Section 4.5.9, the shields of the ABAM-type cables that connect the H2TU-C-231 List 1E DSX-1 output ports to the cross-connect panel must be grounded at both ends.

- 1 Align the H2TU-C with the enclosure slot guides and slide the unit in. Push the unit back until it touches the backplane card-edge connector and the retaining latch on the front panel opens.
- 2 Place your thumbs on the front panel and push the H2TU-C into the card-edge connector until the retaining latch closes. This indicates that the card is properly seated.

VERIFICATION

Once the H2TU-C-231 is installed, verify that it is operating properly. To do this, monitor the following:

- Status LED
- Status messages reported by the front-panel display ([Table 2 on page 6](#)).

Verification without a Downstream Device

If there is no downstream device installed:

- 1 Verify that the H2TU-C powers up. The front-panel display illuminates and reports status messages. (See [Table 2 on page 6](#) for a list of messages.)
- 2 Verify that the H2TU-C attempts to communicate with downstream devices (status LED flashes red). Even if a downstream device is not present, the following events should occur:
 - a The front-panel display reports various four-character status messages.
 - b The H2TU-C again attempts communication until a downstream device is detected.

Verification with a Downstream Device

If a downstream device has been installed:

- 1 Verify that the H2TU-C powers up. (The front-panel display illuminates and reports various status messages.)
- 2 Verify that the H2TU-C attempts to communicate with downstream devices (status LED flashes red). One of the following occurs:
 - If downstream devices are successfully identified and the HDSL2 loop synchronizes, the H2TU-C status LED lights a steady green. The H2TU-C reports normal margin messages on the front-panel display.
 - If downstream devices are not successfully identified, the H2TU-C reports four-character status messages. The H2TU-C attempts communication again and reports four-character status messages. The H2TU-C repeats this cycle until a downstream device is detected.
- 3 If there is more than one span, verify that each subsequent span synchronizes normally by monitoring the front-panel display messages.
- 4 If a remote unit is installed, verify that the last span synchronizes normally. The H2TU-C status LED should light a steady green and the front-panel display should report normal margin messages.
- 5 Verify that a valid DS1 signal has been applied to the H2TU-C and the H2TU-R.
 - If no DS1 signal is being applied to either the H2TU-C or the H2TU-R inputs, then the appropriate DS1 alarms (LLOS or RLOS) display on the front panel and the status LED flashes red.
 - If a valid DS1 signal is being supplied to the H2TU-C and H2TU-R, then DS1 alarm indications should be absent and the status LED lights a steady green.

PROVISIONING REQUIREMENTS

Refer to “[Provisioning](#)” on [page 12](#) for instructions on configuring and monitoring the H2TU-C-231.

The H2TU-C-231 List 1E can be provisioned by using the MODE and SEL buttons on the front panel or by accessing the HiGain HDSL2 maintenance screens. While the MODE and SEL buttons can be used to manually accomplish some provisioning tasks, such as setting system options, the HiGain HDSL2 maintenance screens (available when you connect a PC to the craft port) can handle all provisioning tasks.

After a successful installation, complete the following tasks:

- 1 Set the date and time (see “[Setting Date and Time](#)” on [page 16](#)).
- 2 Set the circuit ID number (see “[Setting Circuit ID Numbers](#)” on [page 17](#)).
- 3 Make any desired changes to configuration (see “[Making Changes to the System Configuration](#)” on [page 18](#)).
- 4 Clear the Performance, Alarm history, and Event Log screens to remove miscellaneous data acquired during startup, or use Master Clear in the Config Menu. This ensures the collection of accurate and meaningful data. (See “[Clearing the History, Alarm, and Event Log Screens](#)” on [page 30](#).)

PROVISIONING

There are two methods for provisioning:

- Use the MODE and SEL buttons on the front panel of the H2TU-C to:
 - Set system options
 - Reset the H2TU-C to its factory default settings for system options
 - Display system option settings (scroll mode)
 - Select system loopbacks
- Use a maintenance terminal (ASCII terminal or a PC running terminal emulation software) connected to the H2TU-C craft port (or to an HMU craft port) to access the HiGain HDSL2 maintenance screens ([Figure 4 on page 15](#)). This gives you full access to all H2TU-C status, history, inventory, and provisioning screens.



No dip switches or jumpers are required to provision the H2TU-C-231 as it contains a non-volatile RAM (NVRAM) which stores the system option settings. System option settings are retained if shelf power is lost or if the H2TU-C-231 is unplugged.

USING THE MODE AND SEL BUTTONS

Setting Options through MODE and SEL

To provision the H2TU-C-231 List 1E through the MODE and SEL buttons on the front panel:

- 1 Press the MODE button for 1 second and release it. The front-panel display alternately shows the first system parameter and its current setting.
- 2 Press the SEL button to step through all possible settings of the selected parameter.
- 3 After the desired setting has been selected, press the MODE button. This updates the currently displayed parameter to the selected setting, then advances to the next configurable parameter. After the last parameter has been selected, a CONF NO message appears on the front-panel display.
- 4 Do one of the following:
 - To cancel the session without saving the requested parameter changes, press the MODE button or do nothing. (After 30 seconds, the display returns to its normal mode without saving the new changes.)
 - To accept the requested parameter changes, press the SEL button. (A CONF YES message displays and returns to its normal mode after saving the new changes.)

Resetting to Factory Default Values

All user options for the H2TU-C-231 List 1E (Table 6 on page 21) can be set to the factory default values using the MODE and SEL buttons. To set the user options to their default values:

- 1 Press the SEL button for 6 seconds until the following message appears:

DFLT NO

- 2 Press the SEL button while the DFLT NO message is displayed.

The message changes to DFLT YES indicating the factory default values are now in effect and the display returns to the normal mode.

To terminate the DFLT mode without setting the factory default values, do one of the following:

- Press the MODE button to return to the normal display mode.
- Wait 30 seconds for the unit to return to the normal display mode.

Displaying System Parameter Settings

To scroll through the current settings of all system parameters, press the MODE button for 3 or more seconds. The H2TU-C displays the following parameters:

- H2TU-C-231 List 1E software version number
- H2TU-C-231 list number
- Type of frame pattern received from the DSX-1
- Line code of the signal received from the DSX-1
- All user-configured parameter settings
- Loop attenuation threshold setting
- Margin alarm threshold setting

Disabling an Alarm

If the system is in a Minor alarm state, the alarm relay can be disengaged by pressing the SEL button. This turns off the Alarm CutOff (ACO) indication.

Loopback Modes

See “Loopback Operation” on page 48 for instructions on using the MODE and SEL buttons to activate loopbacks.

USING A MAINTENANCE TERMINAL

Connecting to a Maintenance Terminal

The craft port on the front panel allows you to connect the H2TU-C-231 to a maintenance terminal (ASCII terminal or PC running a terminal emulation program). Once connected to a maintenance terminal, you can access the maintenance, provisioning, and performance screens.

To connect to a maintenance terminal:

- 1 Connect a standard 9-pin terminal cable to the RS-232 craft port (Figure 2 on page 4) on the H2TU-C-231 front panel.
- 2 Connect the other end of the cable to the serial port on the maintenance terminal.
- 3 Start a terminal emulation program such as ProComm (emulating a VT100 terminal).
- 4 Configure the maintenance terminal to the following communication settings:
 - 9600 baud
 - No parity
 - 8 data bits
 - 1 stop bit
 - Hardware flow control to OFF
- 5 If necessary, press **CTRL** + **R** to refresh the HiGain HDSL2 logon screen.

The Logon Screen

The HiGain HDSL2 maintenance terminal screens allow you to monitor, provision, and troubleshoot an H2TU-C-231 system.

To select a menu from the HiGain HDSL2 logon screen (Figure 4 on page 15), do one of the following:

- Press the first letter of the menu.
- Use the **←** **→** arrow keys to select the menu, and then press **ENTER**.

Table 3 summarizes the navigational keys. They are also listed in the onscreen Help menu. Table 4 on page 15 describes the Logon screen menus.

Table 3. *Navigational Keys for the HiGain HDSL2 Maintenance Terminal Screens*

Key ^(a)	Function
SPACEBAR	Cycle through selections.
ENTER	Activate the current setting or choice, or display a menu.
ESC or F11 (VT100)	Return to the parent menu.
↑ or CTRL + E	Select the submenu or item above the current one, or return to the previous menu.
↓ or CTRL + X	Select the submenu or item below the current one.
→ or CTRL + D	Select the menu or item to the right of the current one.
← or CTRL + S	Select the menu or item to the left of the current one, or return to the previous menu.
CTRL + R	Refresh the screen.

(a) Legacy management units require use of control keys instead of arrow keys.

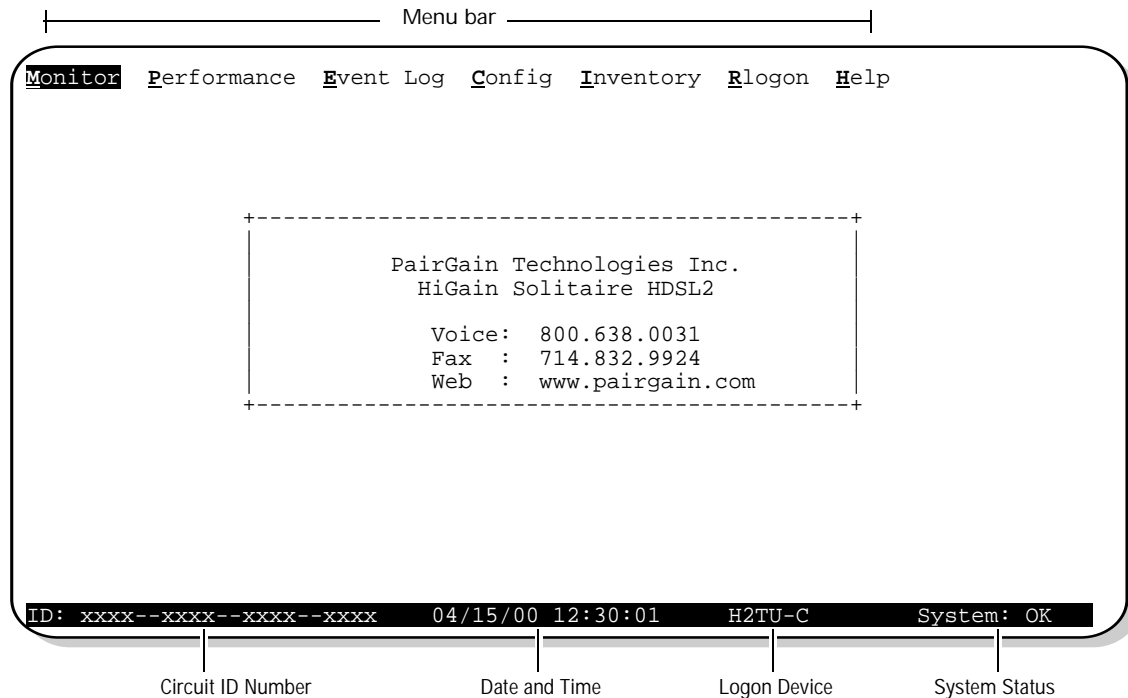

Figure 4. Logon Screen

Table 4. Logon Screen Menus

Press this key:	To access this menu:	Menu Functions
M	Monitor	Monitors loopbacks and alarms, and provides a graphical representation of circuit activity, including ES, UAS, SES, and line code.
P	Performance	Provides performance and alarm histories for current, 25-hour, 48-hour, or 31-day periods for either the DS1 or HDSL2 interface.
E	Event Log	Identifies the 100 most recent system events and reports the date and time of occurrence.
C	Config	Provides standard configuration options, PairGain options, date and time setting, and a reset option (factory settings).
I	Inventory	Provides product information about the various devices that are in the system and lists circuit and device identifications.
R	Rlogon / Rlogout	Remote logon can be performed from the H2TU-C or H2TU-R. The screen displays "Rlogout" when the H2TU-C or H2TU-R is remotely logged on to the other unit at the end of the circuit. To logoff the remote unit, press R . "Rlogout" changes to "Rlogon". The unit is now locally logged on until R is pressed again to re-initiate the remote logon.
H	Help	Provides a glossary of terms used in the HiGain HDSL2 maintenance screens, a list of navigational keys, and ADC contact information.

PROVISIONING TASKS

After H2TU-C-231 is successfully installed, perform these basic provisioning tasks.

- Set date and time
- Set circuit ID numbers
- Make any necessary configuration changes
- Clear history, alarm, and event log screens to remove miscellaneous data during startup

Setting Date and Time

```
Monitor Performance Event Log Config Inventory Rlogon Help
+-----+
| Standard Options -> |
| PairGain Options -> |
| Date and Time -> |
+-----+
| Date (mm/dd/yyyy): 04/15/2000 |
| Time (hh:mm[:ss]): 12:30:01 |
+-----+
ID: xxxx--xxxx--xxxx--xxxx 04/15/00 12:30:01 H2TU-C System: OK
```

Figure 5. Configuration Menu - Date and Time

- 1 Press **C** to select the Config menu.
- 2 Use the **↑** and **↓** arrow keys to select **Date and Time**, then press **ENTER**.
- 3 Type the date in the format indicated, then press **ENTER**.
- 4 Type the time in the format indicated (entering seconds is optional), then press **ENTER**.

Setting Circuit ID Numbers

The Inventory screen provides product information on all units in the system and allows the setting of the circuit and unit identification numbers.

```

Monitor Performance Event Log Config Inventory Rlogon Help
-----
Product Information -----
Unit      : H2TU-C          H2TU-R
Product   : H2TU-C-231     H2TU-R-402
List      : 1E             4E
Sw Ver.   : 2.00           2.00
Build #   : 00             00
Checksum  : 0x3FAE         0x3FAE
H2 Xcvr   : L1-RA2 1.31    L1-RA2 1.31
Serial #  : 01232456789    0123456789
CLEI     : VACHKVYCAA      VARHJUUCAA
Mfg. Date: 04/05/00        04/05/00
-----
Circuit and Unit Identifications -----
Circuit ID : xxxx--xxxx--xxxx--xxxx
H2TU-R ID  : yyyy--yyyy--yyyy--yyyy

Enter new ID and press <Enter> to set.
ID: xxxx--xxxx--xxxx--xxxx 04/15/00 12:30:01 H2TU-C System: OK

```

Figure 6. Inventory Screen

- 1 Press **I** to select the Inventory screen.
- 2 Type the Circuit ID number, then press **ENTER**.
- 3 Type the ID numbers of all other devices listed in the system, pressing **ENTER** after each entry.

Making Changes to the System Configuration

The Config menu (Figure 7) allows you to make the following types of system configuration changes:

- Standard options (Figure 8 on page 19)
- PairGain options (Figure 9 on page 19)
- Date and time (see “Setting Date and Time” on page 16)
- Master clear (see “Clearing the History, Alarm, and Event Log Screens” on page 30)
- Reset to factory default configuration (Figure 10 on page 29)

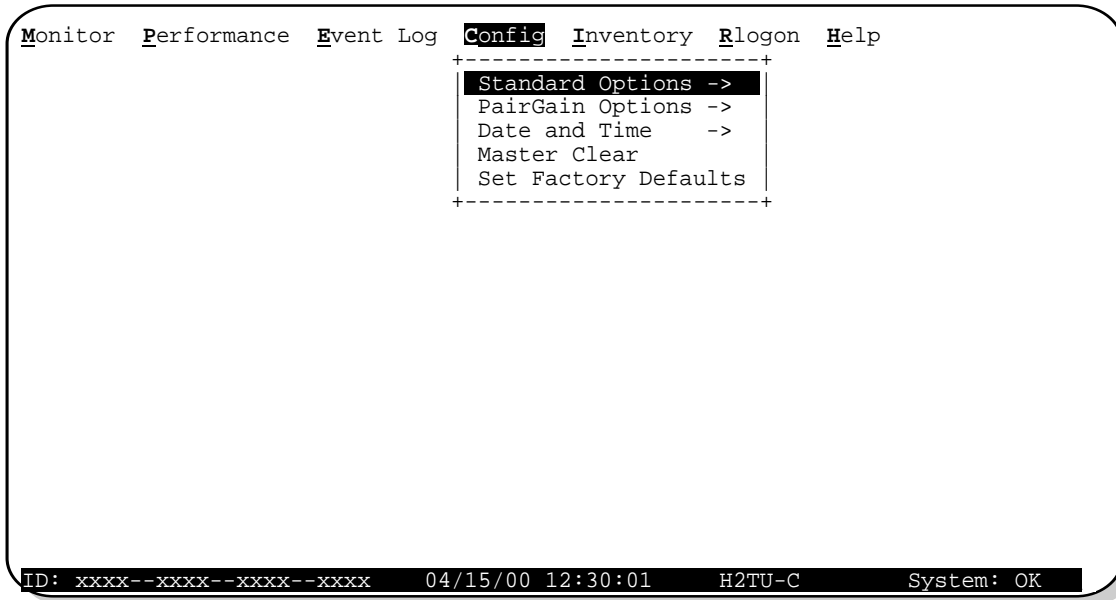

Figure 7. Configuration Menu

Making Changes to Standard and PairGain Options

Figure 8 and Figure 9 on page 19 show the Standard and PairGain configuration options. Standard options are those that are supported by HiGain HDSL2 units when connected to units from other vendors. PairGain options are an extended set of options that are only available when using HiGain units exclusively. For a description of each option and a list of possible option settings, refer to Table 5 on page 20 and Table 6 on page 21. To make changes to these options:

- 1 Press **C** to select the Config menu.
- 2 Use the **↑** and **↓** arrow keys to select **Standard Options** or **PairGain Options**, and press **ENTER**.
- 3 Use the arrow keys to select an option.
- 4 Press the **SPACEBAR** to cycle through the available settings for that option.
- 5 Press **ENTER** to activate your choice.

```

Monitor Performance Event Log Config Inventory Rlogon Help
+-----+
| Standard Options -> |
+-----+
Loopback Timeout (LBTO) : 120 min
Loop Attenuation Threshold (LATT) [0-40]: 35 dB
Margin Threshold (MARG) [0-15]: 4 dB
DS1 Frame Formatting (FRMG) : AUTO
DS1 Line coding (DS1) : B8ZS
H2TU-C Equalization (EQL) : EXT
H2TU-R Line Buildout (RLBO) : -7.5 dB
Alarm Pattern (ALMP) : AIS
H2TU-R TLOS Loopback (TLOS) : DIS
Network Loopback Pattern (NLBP) : AIS
+-----+

Press <Space> to cycle through settings and <Enter> to activate.
ID: xxxx--xxxx--xxxx--xxxx 04/15/00 12:30:01 H2TU-C System: OK

```

Figure 8. Configuration Menu - Standard Options (Defaults Shown)

```

Monitor Performance Event Log Config Inventory Rlogon Help
+-----+
| Standard Options -> |
| PairGain Options -> |
+-----+
Line Power Feed (PWRP) : ON
Remote Provisioning (RTPV) : ENA
Bipolar Violation Transparency (BPVT) : DIS
HDSL2 BER Threshold (HBER) : 1E-6
DS1 BER (DBER) : DIS
Special Loopback Mode (SPLB) : A4LB
SmartJack Loopback (LPBK) : ENA
Minor Alarm (ALM) : DIS
Network AIS Signal (NAIS) : CI
H2TU-R DS1 Frame Conversion (CONV) : ACON
Performance Report Messaging (PRM) : S+N
ESF-RAI to SF-RAI Overwrite (ROVR) : ENA
SF-RAI to SF-RAI-CI toward NET (RACI) : ENA
Fractional T1 Mode (FT1) : DIS
+-----+

Press <Space> to cycle through settings and <Enter> to activate.
ID: xxxx--xxxx--xxxx--xxxx 04/15/00 12:30:01 H2TU-C System: OK

```

Figure 9. Configuration Menu - PairGain Options (Defaults Shown)

Table 5 describes the Standard Config screen options and lists their front-panel display codes. **Table 6 on page 21** describes the PairGain Config screen options and lists their front-panel display codes. Selections in bold typeface are the factory default settings.

Table 5. H2TU-C-231 List 1E Standard Config Screen Options

System Settings Screen Options	Front-panel Display Code	Selection	Description
Loopback Timeout	LBTO	NONE	Disables automatic time-out cancellation of all loopbacks.
		20	Sets automatic cancellation of all loopbacks to 20 minutes after initiation.
		60	Sets automatic cancellation of all loopbacks to 60 minutes after initiation.
		120	Sets automatic cancellation of all loopbacks to 120 minutes after initiation.
Loop Attenuation Threshold	LATT	0 through 40 dB	Determines the maximum loop attenuation before an alarm is declared. Zero disables the alarm. The loop attenuation threshold can only be set through the HDSL2 maintenance screens.
		35 dB	Default value.
Margin Threshold	MARG	0 to 15 dB	Determines the minimum allowable margin below which a system alarm can occur. Zero disables the alarm. The Margin (Alarm) Threshold can only be set through the HiGain HDSL2 maintenance screens.
		4dB	Default value.
DS1 Frame Formatting	FRMG	AUTO	Configures the HiGain HDSL2 system to operate in an auto-framing (AUTO) mode. It detects and locks to both SF or ESF DS1 frame patterns. Line and path performance parameters are maintained and displayed. Unframed payloads will cause the ES-P and SES-P counters to increment.
		UNFR	Configures the same as AUTO except unframed payloads do not cause the ES-P and SES-P counters to increment.
DS1 Line Coding	DS1	B8ZS	Places both the H2TU-C and H2TU-R into their B8ZS modes. Applies to both the MUX (port 2) and AUX (port 1) interfaces.
		AMI	Places both the H2TU-c and H2TU-R into their AMI modes. Applies to both the MUX (port 2) and AUX (port 1) interfaces.
H2TU-C Equalization (See "H2TU-C Equalization (EQL) Option." on page 23.)	EQL	EXT	Disables the H2TU-C internal equalizer, allowing connection of external equalizer hardware to perform the same or a similar function.
		0	Sets the Equalizer to DSX-1 for 0 to 132 feet.
		133	Sets the Equalizer to DSX-1 for 133 to 265 feet.
		266	Sets the Equalizer to DSX-1 for 266 to 398 feet.
		399	Sets the Equalizer to DSX-1 for 399 to 532 feet.
		533	Sets the Equalizer to DSX-1 for 533 to 655 feet.
H2TU-R Line Buildout	RLBO		Sets the DS1 receive level output toward the Customer Interface (CI). H2TU-R Line Buildout can only be set through the HDSL2 maintenance screens.
		0 dB	Sets the DS1 RLBO level toward the CI to 0 dB.
		-7.5 dB	Sets the DS1 RLBO level toward the CI to -7.5 dB.
		-15.0 dB	Sets the DS1 RLBO level toward the CI to -15.0 dB.
Alarm Pattern	ALMP	AIS	Enables the HiGain HDSL2 system to output an AIS payload at its DS1 ports for LOSW and DS1 LOS. For priority resolution, see Figure 24 on page 47 .
		LOS	Enables the HiGain HDSL2 system to output an LOS condition at its DS1 ports for LOSW and DS1 LOS.

Table 5. H2TU-C-231 List 1E Standard Config Screen Options (Cont.)

System Settings Screen Options	Front-panel Display Code	Selection	Description
H2TU-R TOS Loopback	TLOS	ENA	Enables a logic loopback at the H2TU-R when an LOS occurs at its DS1 input, if enabled at the H2TU-R. For priority resolution, see Figure 24 on page 47 .
		DIS	Disables Transmit Loss of Signal (TLOS) logic loopback.
Network Loopback Pattern	NLBP	AIS	Enables the H2TU-R to transmit an AIS towards CI for any network loopback. For priority resolution, see Figure 24 on page 47 .
		LOS	Enables the H2TU-R to transmit an LOS towards CI for any network loopback.

Table 6. H2TU-C-231 List 1E PairGain Config Screen Options

System Settings Screen Options	Front-panel Display Code	Selection	Description
Line Power Feed	PWRF	OFF	Disables powering to the HDSL2 pair.
		ON	Keeps the HDSL2 line voltage at nominal -185 Vdc.
Remote Provisioning	RTPV	ENA	Enables remote provisioning.
		DIS	Disables remote provisioning.
Bipolar Violation Transparency (See "Bipolar Violation Transparency (BPVT) Option" on page 23.)	BPVT	ENA	Enables BPVs and HDSL2 CRC errors at the DS1 input to be converted into DS1 BPVs at the DS1 output at the distant end. This makes HiGain HDSL2 transparent to BPVs.
		DIS	Disables BPV Transparency.
HDSL2 BER Threshold (See "HDSL2 BER Threshold (HBER) Option" on page 23 and "System Alarm Output Pins" on page 61.)	HBER	1E-6	System alarm relay contact closes and the Status LED flashes red when the Block Error Rate exceeds 10^{-6} . (Block Error Rate is based on the definition of Bit Error Rate.)
		1E-7	System alarm relay contact closes and the Status LED flashes red when BER exceeds 10^{-7} .
		NONE	Prevents generation of a system alarm due to BER.
DS1 BER Threshold (See "DS1 BER (DBER) Option" on page 23.)	DBER	ENA	Enables the fixed 24-hour DS1 BER threshold.
		DIS	Prevents the generation of a system alarm due to DS1 BER.
Special Loopback Mode	SPLB	GNLB	Configures the HiGain HDSL2 system to respond to the generic inband loopback codes.
		A2LB	Configures the HiGain HDSL2 system to respond to the inband loopback codes of the Teltrend addressable repeater.
		A3LB	Configures the HiGain HDSL2 system to respond to the inband loopback codes of the Wescom addressable repeater.
		A4LB	Configures the HiGain HDSL2 system to respond to the inband loopback codes of the Wescom Mod 1 addressable repeater.
SmartJack Loopback	LPBK	ENA	Enables the HiGain HDSL2 system to recognize all inband SmartJack (SMJK) loopback commands.
		DIS	Configures the HiGain HDSL2 system to ignore all inband SmartJack loopback commands.

Table 6. H2TU-C-231 List 1E PairGain Config Screen Options (Cont.)

System Settings Screen Options	Front-panel Display Code	Selection	Description
Minor Alarm	ALM	ENA	Enables the generation of the output alarm on pins 20 and 21 when a system alarm condition occurs.
		DIS	Disables the generation of the output alarm on pins 20 and 21 when a system alarm condition occurs.
Network AIS Pattern	NAIS	CI	If ALMP is set to AIS, this option specifies which pattern is sent to the network when a remote LOS or AIS occurs. When configured for CI, an AIS-CI pattern is sent to the network. For priority resolution, see Figure 24 on page 47 .
		AIS	When configured for AIS, an AIS pattern is sent to the network.
H2TU-R DS1 Frame Conversion (See "H2TU-R DS1 Frame Conversion (CONV) Option" on page 24.)	CONV	OFF	Framing determined by the DS1 frame formatting option.
		ACON	Auto (ACON) detection of framing and potential frame conversion at the remote.
		FCON	Auto detection of framing and forced frame format conversion (FCON) at the H2TU-R.
Performance Report Messaging	PRM	SPRM	The H2TU-R generates Supplemental PRM (SPRM) every second if no PRM is present from the CPE within 5 seconds of a reset or an LOS/AIS/OOF condition occurs. TL1 commands and responses are enabled.
		NPRM	The H2TU-R generates Network PRM (NPRM) if no PRM is present from the CPE. If the CPE is sending PRMs, NPRM is generated in addition to the existing PRM every second. TL1 commands and responses are enabled.
		S + N	The H2TU-R generates an NPRM which is tagged on to an SPRM every second. The H2TU-R generates SPRM if no PRM is present from the CPE. If the CPE is sending PRM, the PRM is converted to an SPRM. TL1 commands and responses are enabled.
		OFF	ESF Datalink (DL) is completely transparent. No PRMs are generated. There are no TL1 responses unless the system is first armed by a TL1 command, which enables Performance Monitoring.
ESF-RAI to SF-RAI Overwrite (See "ESF-RAI to SF-RAI Overwrite (ROVR) Option" on page 28.)	ROVR	ENA	If the CONV option is set to FCON or ACON, an ESF DS1 payload from the network with an embedded RAI pattern is converted to an SF-RAI pattern towards the CI at the H2TU-R.
		DIS	Prevents conversion to an SF-RAI pattern.
SF-RAI to SF-RAI-CI towards NET (See "SF-RAI to SF-RAI-CI toward NET (RACI) Option" on page 28.)	RACI	ENA	Allows DS1 SF-RAI (yellow alarm) signal received by the H2TU-R to be converted to an SF-RAI-CI signal towards the network.
		DIS	Prevents conversion of the DS1 SF-RAI.
Fractional T1 Mode (See "Fractional T1 Mode (FT1) Option" on page 26.)	FT1	ENA	Enables system response to DDS latching loopback commands for fractional T1 applications, CP disconnect, and trouble indication. For priority resolution, see Figure 24 on page 47 .
		DIS	Disables system response to DDS latching loopback commands for fractional T1 applications, CP disconnect, and trouble indication.

HDSL2 BER Threshold (HBER) Option. The HBER option permits the monitoring of loop integrity and reporting of alarms when excessive errors are detected. The PM primitive used for this purpose is the CRC checksum performed on the HDSL2 frame for both directions of transmission. It is, therefore, called a block error rate rather than the bit error rate associated with the DS1 interface. The CRC errors and counts are displayed on the Monitor screen for both the H2TU-C and H2TU-R. The HBER option allows an alarm to be generated if the total number of CRCs at either the H2TU-C or H2TU-R exceeds the selected BER threshold during the last 1-minute interval.

- HBER option = 1E-6. Alarm is generated if CRC > 92
- HBER option = 1E-7. Alarm is generated if CRC > 9

Once initiated, the HBER count clears when the CRC count drops below the selected threshold. Selecting NONE inhibits this alarm.

H2TU-C Equalization (EQL) Option. Equalization is the configuration of system transmission characteristics within specified limits. An adaptive equalizer inserts a frequency-shaped loss that corresponds to an equivalent addition of an appropriate cable length. By simulating the additional cable loss necessary for correct operation, the equalizer compensates for a range of variation in transmission path characteristics.

Bipolar Violation Transparency (BPVT) Option. The H2TU-C-231 improves compatibility with Digital Loop Carrier (DLC) feeder applications because of its ability to transmit DS1 BPV occurrences between its DS1 interfaces. This feature is required to support protection switching in DLC applications. Each DLC terminal must be able to monitor the integrity of its Receive DS1 payload and then switch to the protect line when the integrity of the path drops below specific user selected limits. An essential requirement of this feature is the need for each DLC terminal to detect BPVs in its DS1 input. Standard HDSL systems correct DS1 BPVs at the input and therefore prevent them from being detected by the DLC terminals to which they are connected. The H2TU-C-231 and its associated remote units remove this limitation and become BPV transparent by detecting and counting input BPVs at each end and then by replicating them at the DS1 output port of the distant end.

The BPV count is converted into BPVs at the distant end during the following second at a rate of 1 BPV every 128 DS1 bits up to a maximum of 12000 ($BER=7.7 \times 10^{-3}$). This maximum rate is more than adequate since it exceeds the maximum 10^{-3} BER required by most DLC systems.

DS1 BER (DBER) Option. The DS1 BER alarm occurs when any of the DS1 or DSX-1 performance monitoring parameters listed in [Table 7](#) exceed the counts shown for the 24-hour period between 12:00:00 AM through 11:59:59 PM. These thresholds correspond to a 10^{-6} BER. All PM counters clear to zero at 12:00:00 AM or when Master Clear is selected.

Table 7. DS1/DSX-1 24-hour PM Threshold

Parameter	Threshold Count
CV-L (BPV)	133,400
ES-L, ES-P, PRM, PDVS-L	648
SES-L, SES-P	100
UAS-P, UAS-L	10

H2TU-R DS1 Frame Conversion (CONV) Option. Frame format conversion is only applicable to the remote H2TU-R, but selectable by the H2TU-C or H2TU-R. This option enables the network to be ESF, which is used to embed SPRM or NPRM into the datalink towards the network. During conversion, frame bit errors are regenerated to ensure transparency.

The HDSL2 system attempts to find ESF or SF framing or determines that no framing exists. The DS1 framing is then synchronized with the HDSL2 frame. If the framing is lost, the system generates an Out-of-Frame (OOF) defect which results in UAS-P. As a result, the system reverts to frame search mode.

This option has the following settings:

- **OFF:** No frame conversion takes place. All framing issues are determined by the FRMG option settings of AUTO and UNFR.
- **ACON:** This is the automatic conversion setting. If the system detects ESF from the network and SF from the CPE, it automatically converts the CPE SF to ESF towards the network as well as the network ESF to SF towards the CPE.

Upon power-on-reset, after loopdown, or after changing the frame conversion option, the framing needs to be re-established before a complete conversion takes place. If there is a failure condition (LOS, AIS, or LOF) during steady state, the previous conversion state is maintained to ensure continuity when the system returns from the failure condition.

If SF is received from the network, the H2TU-R forces an ESF towards the network for about 1.5 seconds. This signals to the far-end PM-NIU at the network boundary that frame conversion is requested. If the far-end PM-NIU is capable of conversion, it changes the framing to ESF. If not, then the H2TU-R reverts to SF and does not apply any conversion.

If an ESF is received from the CPE, it is passed on to the network, and the network's inbound framing is passed on to the CPE.

- **FCON:** This is the forced conversion setting. [Table 8](#) lists the HiGain HDSL2 responses to both the ACON and FCON settings for the CONV option. The responses are identical, except in cases 3 and 4. In these cases, the FCON reply is attempting to force the network (or the far-end PM-NIU) to send ESF. It also alerts the CPE with an AIS alarm pattern while forcing the ESF to the network. Continuity is maintained as for ACON. [Table 9 on page 25](#) and [Table 10 on page 26](#) list the ESF and SF frame formats, respectively.

Table 8. Response to H2TU-R DS1 Frame Conversion Options

Case Number	NET Transmit	CPE Transmit	ACON Option	FCON Option
			NET > CPE NET < CPE	NET > CPE NET < CPE
1	ESF	SF	ESF → SF ESF ← SF	ESF → SF ESF ← SF
2	ESF	ESF	ESF → ESF ESF ← ESF	ESF → ESF ESF ← ESF
3	SF	ESF	SF → SF ESF ← ESF	SF → AIS ESF ← ESF
4	SF	SF	SF → SF SF ← SF	SF → AIS ESF ← SF

Table 9. *Extended SuperFrame Format*

ESF Number	Frame Bits		
	Framing Pattern Sequence (FPS) - 2 kb/s	Frame Bit for Datalink (FDL) - 4 kb/s	Cyclical Redundancy Check (CRC) Bits - 2 kb/s
1		m	
2			C1
3		m	
4	0		
5		m	
6			C2
7		m	
8	0		
9		m	
10			C3
11		m	
12	1		
13		m	
14			C4
15		m	
16	0		
17		m	
18			C5
19		m	
20	1		
21		m	
22			C6
23		m	
24	1		

Table 10. *SuperFrame Format*

SF Number	Frame Bits	
	Terminal Framing Bit	SuperFrame Signaling Bit
1	1	
2		0
3	0	
4		0
5	1	
6		1
7	0	
8		1
9	1	
10		1
11	0	
12		0

Fractional T1 Mode (FT1) Option. Fractional T1 circuits can be used in feeder networks to provide frame relay service. If such circuits are maintained by a DDS test group, then these circuits must respond to DDS/DS0 latching loopback commands, the only tool test groups have at their disposal. A latching loopback, once it has been initiated by the correct sequence, remains locked or “latched” until the correct loopdown sequence has been detected.

The FT1 option, when enabled, allows the H2TU-C to respond to DS0 latching loopback commands and thus support fractional T1 frame-relay applications. This is in addition to the standard full bandwidth T1 2-in-5 loopup and 3-in-5 loopdown SmartJack commands. FT1 supports both the full T1 commands of ENA and the new DDS latching loopback commands, which must also be enabled. (For more information about latching loopback commands, refer to BellCore TA-TSY-000077, Issue 3, April 1986.)

The FT1 option supports both the DDS NI and DDS DS0 Data Port (DP) latching loopback sequences listed in [Table 11](#).

Table 11. *DDS NI and DS0 DP Latching Loopback Sequence*

Enable Sequence	Minimum Number of Bytes	Byte Name	Network Code
1	35	Transition in Progress (TIP)	S0111010
2A	35	NI Loop Select Code (LSC)	S1000001
2B	35	DS0 DP Loop Select Code (LSC)	S0000101
3	100	Loopback Enable Code (LBE)	S1010110
4	35	All Ones	S1111111
5	100	LBE	S1010110
6	32	Far End Voice (FEV)	S0111010
Disable/Loopdown	35	TIP	S0111010

The sequences in [Table 11](#) are sent in timeslot 1. The S in the Network Code column is a “don’t care” bit. The loopback is activated after the detection of Sequence 6. Upon completion of the enable sequence, the Test Center continues to transmit FEV bytes in multiples of 20 until FEV confirmation bytes are returned or until about 2 seconds have elapsed. If the confirmation bytes are not received, a failed attempt is reported. Anticipate the minimum number of bytes when the loopback code is transmitted by a pre-programmed machine test pattern generator. These minimum number of bytes will most likely be exceeded when the codes are sent manually. Also, manual testing may inject random data signals between valid control sequences. The detection algorithm ignores these occurrences and only responds to valid control codes.

[Table 12](#) lists the relationship between the latching loopback sequences and the specific HiGain HDSL2 loopback they initiate.

Table 12. *HiGain HDSL2 Loopback vs. Latching Sequence*

HiGain HDSL2 Loopback	Latching Sequence
NREM	1, 2A, 3, 6
NLOC	1, 2B, 3, 6
NRG1	1, 2B, 3, 4, 5, 6
NRG2	1, 2B, 3, 4, 5, 4, 5, 6

The NLOC and NRG1 through NRG2 loopbacks are called tandem DS0 DP loopbacks. They are used to select one of many loopback points when there are several identical data ports in tandem. The NI loopback is assigned to the H2TU-R (NREM) since it is usually located at the Network Interface (NI). The DS0 DP tandem loopback is assigned to the rest of the HiGain HDSL2 loopbacks because most DDS test sets support this tandem command set.

The Test Center transmits a group of 40 TIP bytes to loop down the loopback. It continues to transmit TIP bytes in multiples of 20 until the TIP bytes are not returned or until about 2 seconds have elapsed. If the bytes are absent, a successful loopdown is reported; otherwise, a failed loopdown is reported. The loopdown can also be initiated by depressing the H2TU-R loopback control button or by any of the standard 3-in-5 loopdown commands. The implemented detection/release loopback algorithm functions properly in the presence of a 10^{-3} bit error rate.

Since the FT1 mode is a combination of both the full T1 and the latching loopback modes, all codes are always active. Therefore, if a loopback is initiated by a latching sequence, it can be looped down by either a latching or generic loopback and vice versa. All loopback commands are completely symmetric in the FT1 mode.

If the latching sequence shown in [Table 12](#) is interrupted for more than 20 minutes, the detection is cleared, and the H2TU-C reverts back to its initial state where it searches for the initial sequence 1.

After a successful latching sequence terminates in a latched loopback state, the state remains until the Disable command is detected or until the LBTO option of NONE, 20, 60, or 120 minutes has expired, whichever occurs first.

The unframed AIS pattern that is normally sent towards the network for a CILOS fault condition must be replaced by the new patterns listed in [Table 13 on page 28](#) when the FT1 loopback option is selected. In addition, the FT1 mode also requires an input AIS pattern to be converted into an unframed 7E output pattern at both ends as shown in [Table 13](#).

Table 13. Response of H2TU-C and H2TU-R to LOS and AIS

Case	FT1 Option	H2TU-C Input	H2TU-C Output Pattern			H2TU-R Input	H2TU-R Output	Status Screen	Front-panel Display
			Framing	Payload	FDL				
1	ENA	SF	SF	01111110	N/A	LOS/AIS	01111110 UNFR	RCV RLOS/RAIS XMT IDLE	ALRM RLOS/RAIS
2	ENA	ESF	ESF	01111110	X ^(a)	LOS/AIS	01111110 UNFR	RCV RLOS/RAIS XMT IDLE	ALRM RLOS/RAIS
3	ENA	LOS/AIS	SF	01111110	N/A	LOS/AIS	01111110 UNFR	RCV RLOS/RAIS XMT IDLE	ALRM RLOS/RAIS
4	ENA	LOS/AIS	SF	PL	X ^(a)	SF/PL	AIS	RCV LLOS/LAIS	ALRM LLOS/LAIS
5	ENA	LOS/AIS	SF	PL	X ^(a)	ESF/PL	AIS	RCV LLOS/LAIS	ALRM LLOS/LAIS

(a) Don't care bit

ESF-RAI to SF-RAI Overwrite (ROVR) Option. If the ESF RAI to SF RAI Overwrite (ROVR) option is enabled, it allows a network ESF RAI or ESF RAI-CI pattern to be converted into a CPE SF RAI or SF RAI-CI pattern and overwrites bit 2 of every DS0 channel with a zero.

If the ROVR option is disabled, it prevents conversion of a network ESF payload with an embedded RAI pattern. Disabling the ROVR option preserves the integrity of the CPE payload as it was originally transmitted.

SF-RAI to SF-RAI-CI toward NET (RACI) Option. In general, the Remote Alarm Indication - Customer Installation (RAI-CI) signal is a RAI signal which contains a signature indicating that an LOF or AIS failure has occurred within the customer's network.

RAI-CI is transmitted toward the network when these two conditions are simultaneously true at the point from which RAI-CI is originated (at the H2TU-R, towards the network):

- RAI is received from the CI
- No LOF, LOS, or AIS failure is detected in the signal received from the network.

Since RAI-CI meets the definition of RAI, RAI-CI may be detected and used exactly as an RAI.

For ESF, the RAI-CI signal is a repetitive pattern with a period of 1.08 seconds. RAI-CI is formed by sequentially interleaving 0.99 seconds of the unscheduled message 00000000 11111111 (right-to-left), which represents RAI in the DL, with 90 milliseconds of the message 00111110 11111111 (right-to-left) to flag the signal as RAI-CI.

For SF, the SF-RAI-CI signal is transmitted inband by setting each of the 24 channel time slots to 1000 1011 (left-to-right). In addition to the criteria specified above, the generation of SF-RAI-CI has to be held for 1 second to examine the DS0 channels for the presence of a frame with an all-zeroes pattern. If present, the generation of SF-RAI-CI is suspended for the duration of the all-zeroes pattern.

In all SF environments, the H2TU-R automatically converts a CPE DS1 payload with an embedded RAI signal into an RAI-CI pattern towards the network if the RACI option is enabled (default). Such a conversion affects the payload as described above. Disable RACI to avoid this conversion.



The SF-RAI to SF-RAI-CI option is only applicable in an all SF framing environment. If SF to ESF conversion is active (the CONV option is set to either ACON or FCON), the SF RAI is converted into ESF RAI in the FDL, regardless of the RACI setting.

Resetting the H2TU-C



Resetting the H2TU-C to its original factory settings may cause interruption of service.

To reset the H2TU-C-231 List 1E to its original factory defaults:

- 1 Press **C** to select the Config menu.
- 2 Use the **↑** and **↓** arrow keys to select **Set Factory Defaults**, then press **ENTER**.
- 3 Press **Y** if you are certain you want to reset the H2TU-C, or press **N** to cancel this action.

```

Monitor  Performance  Event Log  Config  Inventory  Rlogon  Help
+-----+
| Standard Options -> |
| PairGain Options -> |
| Date and Time -> |
| Master Clear |
| Set Factory Defaults |
+-----+

SETTING FACTORY DEFAULTS...SERVICE *MAY* BE INTERRUPTED! ARE YOU SURE (Y/N)?
ID: xxxx--xxxx--xxxx--xxxx 04/15/00 12:30:01 H2TU-C System: OK

```

Figure 10. Configuration Menu - Reset to Factory Defaults

Clearing the History, Alarm, and Event Log Screens

Select Master Clear to clear the History, Alarm, and Event Log screens after the system has been installed and is functioning properly. This removes miscellaneous data acquired during the startup session and ensures that you have meaningful data thereafter.

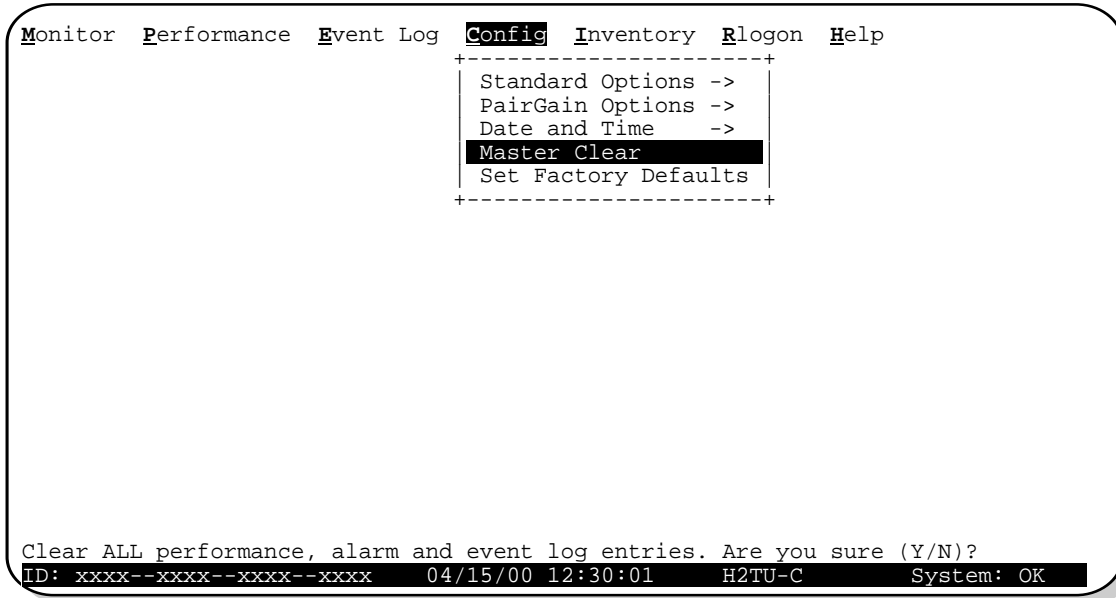

Figure 11. Master Clear

To clear the Event Log, press **E** to select the Event Log screen, then press **L** to clear the screen.

To clear an individual history or alarm screen, do the following:

- 1 Press **P** to select the Performance screen.
- 2 Press the **SPACEBAR** to select either interface (**H2TU-C DS1**, **H2TU-R DS1**, **H2TU-C HDSL2** or **H2TU-R HDSL2**), then press **ENTER**.
- 3 Press the **SPACEBAR** to select the type of statistics (**Current**, **Alarm History**, **25 Hour History**, **48 Hour History**, or **31 Day History**) and press **ENTER** after your selection.
 - Selecting **31 Day History** allows you to clear the Current, 25 Hour, 48 Hour, and 31 Day performance history screens for the selected interface.
 - Selecting **Alarm History** allows you to clear the alarm history screen for the selected interface. For information about the DS1 and HDSL2 Alarm screens, see [Table 17 on page 41](#).
- 4 Press **L** to clear the screen.

To clear ALL history, alarm, and event log screens by this method:

- 1 Press **C** to select the Config screen.
- 2 Select **Master Clear**.
- 3 Press **Y** to clear all screens.

MONITORING SYSTEM ACTIVITY AND PERFORMANCE

The H2TU-C-231 provides two sets of maintenance screens for monitoring system activity and assessing performance.

- The Monitor screens provide a graphical representation of circuit activity and allow initiation of loopbacks.
- The Performance screens provide current, 25-hour, 48-hour, and 31-day performance histories and a continuous alarm history.
- The Event Log provides a description of the 100 most recent events.

SYSTEM OVERVIEW

Future product enhancements will support up to two regenerators with three HDSL2 spans as shown in [Figure 12](#).

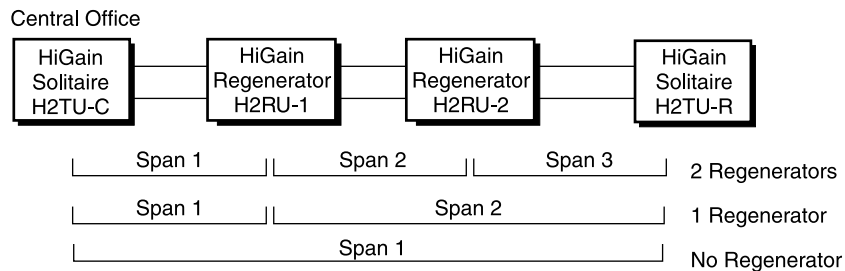

Figure 12. System Spans

The Monitor and Performance screens provide important activity and performance information about the HDSL2 spans and span devices.

USING THE MONITOR SCREEN TO VIEW SYSTEM ACTIVITY

- 1 Press **M** to view the system diagram.

Figure 13 shows an armed circuit with an active loopback and alarms. Terms used on the system diagram are defined in the onscreen Help menu glossary. Abnormal situations are highlighted on the diagram. See Table 14 on page 33 for screen field descriptions.

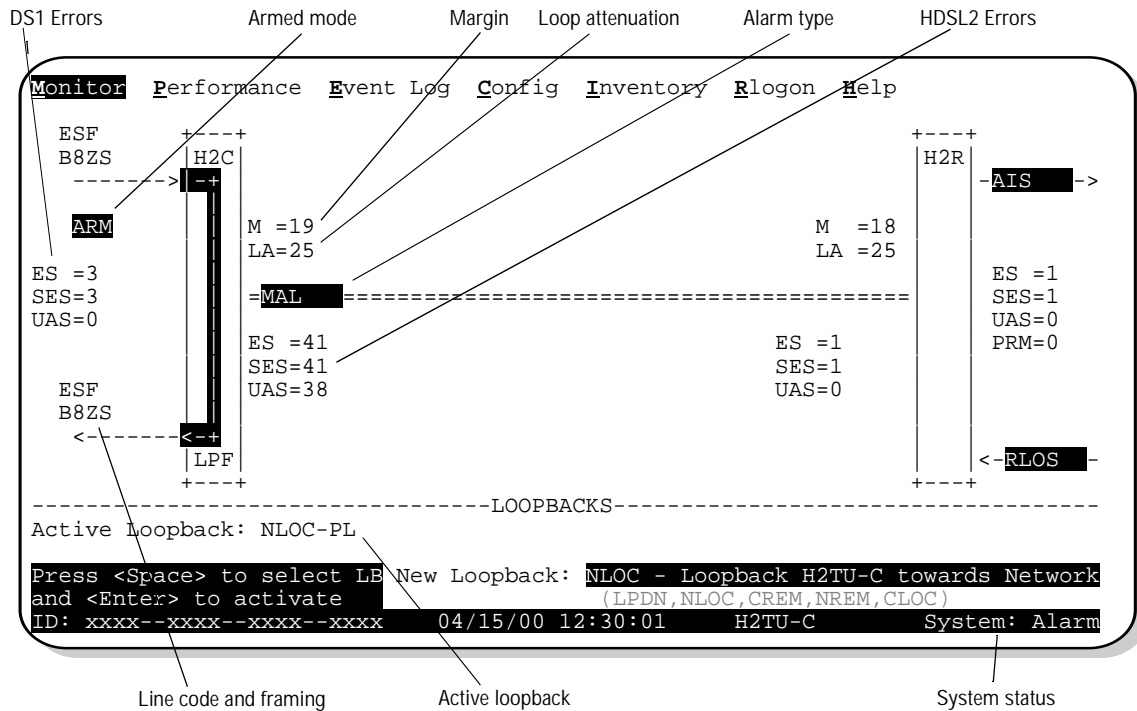

Figure 13. Monitor Screen - Active Loopback with Alarms

- 2 To initiate a loopback, press the **SPACEBAR** to cycle through the loopback choices. Press **ENTER** to make your choice,
 When prompted with the message: Are you sure (Y/N)?, press **Y** to initiate the loopback or **N** to cancel. For more information about loopbacks and troubleshooting, see "Testing" on page 45.
- 3 To initiate a loopdown of all active loopbacks, press the **SPACEBAR** to select **LPDN**, then press **ENTER** or **N**. When prompted with the message: Are you sure (Y/N)?, press **Y** to initiate the loopdown or **N** to cancel.

Table 14. Monitor Screen Descriptions

Field	Description
Active Loopback	An active loopback is indicated on the lower third of the Monitor screen. Available loopbacks are indicated by gray text. See Table 21 on page 49 for a summary of the HiGain HDSL2 loopback codes and activation methods.
Alarm type	Indicates type of alarm.
Armed mode	Indicates system is in an armed state for an intelligent repeater loopback command.
Code type	Type of DS1 line coding used (B8ZS or AMI).
DS1 ES Count	Errored Seconds—The sum of the Errored Seconds-Line (ES-L) and Errored Seconds-Path (ES-P) counts detected on the DS1 input over a 24-hour period. Errors included are: DS1 Frame errors, BPV, and ESF CRC errors.
DS1 SES Count	Severely Errored Seconds—The sum of the DS1 Severely Errored Seconds-Line (SES-L) and Severely Errored Seconds-Path (SES-P) counts over the last 24 hours.
DS1 UAS Count	Unavailable Errored Seconds—The number of seconds during which the DS1 input signal was absent over a 24-hour period.
Frame type	Type of DS1 framing used on the input stream (SF, ESF or UNFR).
HDSL2 ES Count	Errored Seconds—The number of 1-second intervals that contained at least one CRC or LOSW error. This value is a running total of the last 24 Hours.
HDSL2 SES Count	Severely Errored Seconds—The number of 1-second intervals that contain at least 50 CRC errors or one or more LOSW defects. (An LOSW defect occurs when at least three consecutive HDSL2 frames contain one or more frame bit errors.) This value is a running total of the last 24 hours.
HDSL2 UAS Count	Unavailable Errored Seconds—The number of seconds the HDSL2 loop is unavailable. This occurs after 10 contiguous HDSL2 SES and is retired after 10 contiguous non-SES seconds. This value is a running total of the last 24 hours.
ID	Circuit identification (ID) number.
LA	Loop Attenuation—indicates the attenuation of the Overlapped Pulse Amplitude Modulation Transmission with Interlocking Spectra (OPTIS) pulse from the distant end. The value is related to the 196 kHz loss of the cable pair. The loop attenuation is a more direct indication of the loop attenuation to the OPTIS signal than is the 196 kHz loss. The normal HiGain HDSL2 LA operation range is from 0 to 40 dB.
LPF	Line Power Feed—indicates the HDSL2 line power is on.
M	Margin—the signal-to-noise ratio at all HDSL2 ports, relative to a 10^{-7} Bit Error Rate.
MAL	Margin Alarm—Indicates the margin on HDSL2 loop has dropped below the threshold (0 to 15dB) as set by the operator.
PL (or HG)	PL displays when the loopback was initiated by a command embedded in the DS1 data path payload (PL). HG displays when the loopback was initiated from a HiGain (HG) front panel or by a HiGain maintenance terminal loopback command.
PRM	The sum of the Performance Report Messaging-Near End (PRM-NE) and Performance Report Messaging-Far End (PRM-FE) counts.
System Status	The presence or absence of alarms (BER, MARG, LOS, AIS, AIS-CI, RAI, RAI-CI, LA) is indicated on the lower right corner of all screens. See Table 20 on page 45 for a list of the front-panel system alarms.

USING THE PERFORMANCE SCREENS TO VIEW PERFORMANCE DATA

The Performance screens display:

- CRC statistics for the HDSL2 or DS1 interface in 31-day, 48-hour, 25-hour and current history reports.
- Alarm statistics for the HDSL2 (Figure 20) or DS1 interfaces (Figure 21 on page 41) on a continuous basis.

To access the Performance history screens:

- 1 Press **P** to select the Performance screen.
- 2 Press the **SPACEBAR** to select either interface (**H2TU-C DS1**, **H2TU-R DS1**, **H2TU-C HDSL2**, or **H2TU-R HDSL2**), then press **ENTER**.
- 3 Press the **SPACEBAR** to select the type of statistics (**Current**, **Alarm History**, **25 Hour History**, **48 Hour History**, or **31 Day History**), then press **ENTER**.

Performance History at the DS1 Interface

Figure 14 and Figure 15 are examples of an H2TU-R 31-day and H2TU-C 25-hour history DS1 performance screens, respectively, as viewed from the line unit. In addition, there are 48-hour, 25-hour, and current statistic screens for the DS1 interface for the H2TU-R, as well as the H2TU-C. Table 15 describes the acronyms used in the performance history screens.

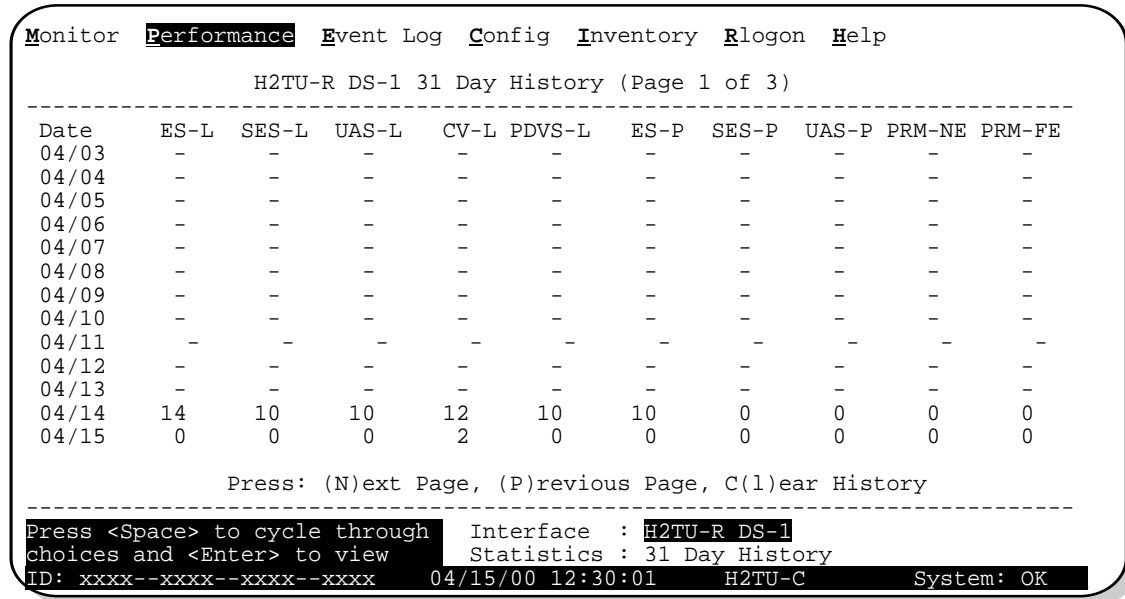

Figure 14. H2TU-R DS1 31-day Performance History

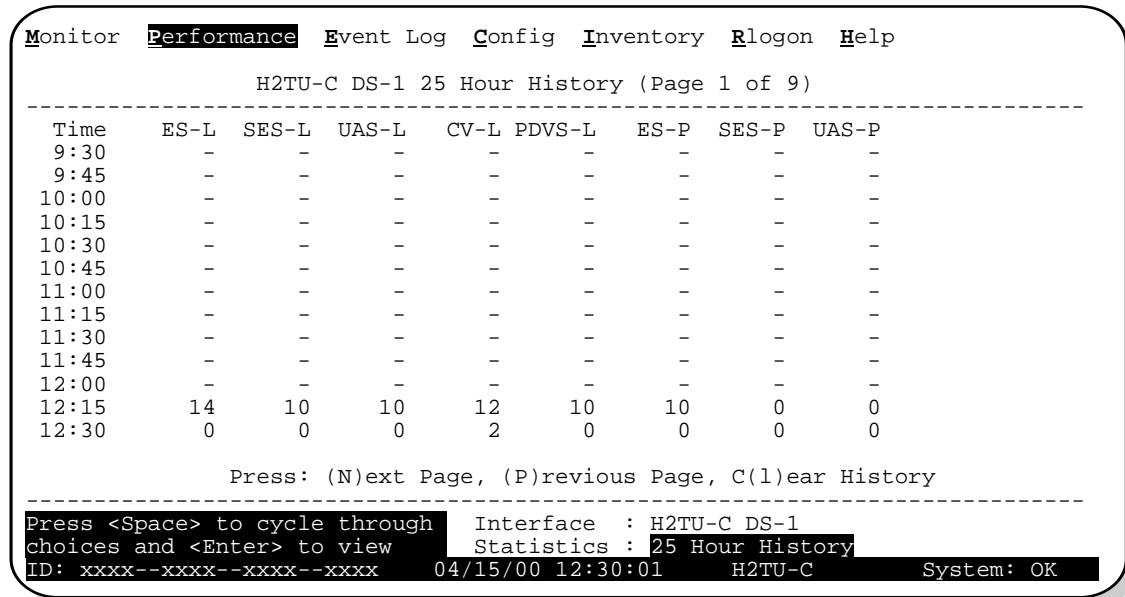

Figure 15. H2TU-C DS1 25-hour Performance History

Table 15. Error Acronyms Used on the DS1 Performance History Screens

Error Acronym	Description	Error Acronym	Description
ES-L	Errored Seconds - Line Seconds with BPV ≥ 1 .	SES-P	Severely errored seconds - Path Seconds with SES or CRC(ESF) ≥ 320 or FE ^(d) (SF) ≥ 8 ($F_T + F_S$).
SES-L	Severely errored seconds - Line Seconds with BPV plus EXZ ≥ 1544 or LOS ≥ 1 .	UAS-P	Unavailable seconds - Path A second of unavailability based on SES-P or AIS ≥ 1 .
UAS-L	Unavailable seconds - Line Seconds with LOS ≥ 1 .	PRM-NE ^(a)	Performance Report Monitoring - Near End The PRM from CPE indicates errors, and the signal received from the network at the remote is error-free.
CV-L	Code Violation - Line Total BPV count.	PRM-FE ^(a)	Performance Report Monitoring - Far End The PRM from the network indicates errors, and the signal received from the CPE is error-free.
PDVS-L	Pulse Density Violation Seconds - Line Seconds with excessive zeroes (AMI = 16 zeroes, B8ZS = 8 zeroes).	B8ZSS ^(b)	B8ZS Monitored Seconds Seconds with B8ZS detection when AMI option is active.
ES-P	Errored Seconds - Path Seconds with SEF ^(c) , CRC (ESF) or FE ^(d) (SF) ≥ 1 .	MSEC ^(b)	Monitored Seconds of the current (15 minute/1 hour/1 day) screen.

(a) Only appears on H2TU-R Performance History screens.

(b) Appears on the DS1 Current Statistics screens.

(c) Severely Errored Frame—Two or more frame bit errors occurring in a 0.75 ms interval for SF or a 3 ms interval for ESF.

(d) FE is a frame bit error.

Performance History at the HDSL2 Interface

Figure 16 is an example of a 31-day HDSL2 performance screen as viewed from the H2TU-C. The HDSL2 interface has 31-day, 48-hour, 25-hour, and current statistic screens for the H2TU-C. Table 16 describes the acronyms used in the performance history screens.

```

Monitor Performance Event Log Config Inventory Rlogon Help
                H2TU-C HDSL2 31 Day History (Page 1 of 3)
-----
Date      ES      SES      UAS      CV      LOSWS
04/03    -        -        -        -        -
04/04    -        -        -        -        -
04/05    -        -        -        -        -
04/06    -        -        -        -        -
04/07    -        -        -        -        -
04/08    -        -        -        -        -
04/09    -        -        -        -        -
04/10    -        -        -        -        -
04/11    -        -        -        -        -
04/12    -        -        -        -        -
04/13    -        -        -        -        -
04/14    -        -        -        -        -
04/15    14      10      10      14      10

                Press: (N)ext Page, (P)revious Page, C(l)ear History
-----
Press <Space> to cycle through choices and <Enter> to view
Interface : H2TU-C HDSL2
Statistics : 31 Day History
ID: xxxx--xxxx--xxxx--xxxx 04/15/00 12:30:01 H2TU-C System: OK

```

Figure 16. H2TU-C HDSL2 31-day Performance History

Table 16. Error Acronyms Used on the HDSL2 Performance History Screens

Error Acronym	Description
ES	Errored seconds Seconds with HDSL2 CRC ≥ 1 or LOSW ≥ 1
SES	Severely errored seconds Seconds with HDSL2 CRC ≥ 50 or LOSW ≥ 1
UAS	Unavailable seconds Based on 10 contiguous SES occurrences
CV	Code Violation Total count of HDSL2 CRC errors.
LOSWS	Loss of Sync Word Second Seconds with LOSW ≥ 1

Current Statistics Screens for the DS1 Interface

Examples of current statistics screens are shown below. [Figure 17](#) and [Figure 18](#) show statistics for the DS1 interface at the remote unit and line unit, respectively. These screens report 1-day, 1-hour, and 15-minute statistics. Refer to [Table 15](#) on [page 36](#) for descriptions of the kinds of errors reported on these screens.

```

Monitor  Performance  Event Log  Config  Inventory  Rlogon  Help
                H2TU-R DS-1 Current Statistics
-----
Start      1 Day   1 Hour   15 Min
          00:00  12:00   12:30
ES-L           0         0         0
SES-L           0         0         0
UAS-L           0         0         0
CV-L           0         0         0
PDVS-L          0         0         0
ES-P           0         0         0
SES-P           0         0         0
UAS-P           0         0         0
PRM-NE          0         0         0
PRM-FE          0         0         0
B8ZSS           0         0         0
MSEC          3482      1801         1
                Press: C(l)ear Current Statistics
-----
Press <Space> to cycle through  Interface : H2TU-R DS-1
choices and <Enter> to view      Statistics : Current
ID: xxxx--xxxx--xxxx--xxxx    04/15/00 12:30:01  H2TU-C      System: OK

```

Figure 17. H2TU-R DS1 Current Statistics

```

Monitor  Performance  Event Log  Config  Inventory  Rlogon  Help
                H2TU-C DS-1 Current Statistics
-----
Start      1 Day   1 Hour   15 Min
          00:00  12:00   12:30
ES-L           0         0         0
SES-L           0         0         0
UAS-L           0         0         0
CV-L           0         0         0
PDVS-L          0         0         0
ES-P           0         0         0
SES-P           0         0         0
UAS-P           0         0         0

B8ZSS           0         0         0
MSEC          3482      1801         1
                Press: C(l)ear Current Statistics
-----
Press <Space> to cycle through  Interface : H2TU-C DS-1
choices and <Enter> to view      Statistics : Current
ID: xxxx--xxxx--xxxx--xxxx    04/15/00 12:30:01  H2TU-C      System: OK

```

Figure 18. H2TU-C DS1 Current Statistics

Current Statistics for HDSL2 Interface

Figure 19 shows statistics for the HDSL2 interface at the H2TU-C. This screen reports 1-day, 1-hour, and 15-minute statistics. Refer to Table 16 on page 37 for descriptions of the kinds of errors reported on this screen.

```

Monitor Performance Event Log Config Inventory Rlogon Help
-----
H2TU-C HDSL2 Current Statistics
-----
Start      1 Day   1 Hour   15 Min
          00:00  12:00   12:30
ES         0       0       0
SES        0       0       0
UAS        0       0       0
CV         0       0       0
LOSWS     3482    1801    1

          Margin(dB)  LA (dB)
Hi         16
Cur       15       25
Low        12

          Press: C(1)ear Current Statistics
-----
Press <Space> to cycle through Interface : H2TU-C HDSL2
choices and <Enter> to view   Statistics : Current
ID: xxxx--xxxx--xxxx--xxxx  04/15/00 12:30:01   H2TU-C   System: OK

```

Figure 19. H2TU-C HDSL2 Current Statistics

USING THE PERFORMANCE SCREENS TO VIEW ALARM DATA

To access the alarm history screens:

- 1 Press **P** to select the Performance menu.
- 2 Press the **SPACEBAR** to select an interface (**H2TU-C DS1**, **H2TU-R DS1**, **H2TU-C HDSL2**, or **H2TU-R HDSL2**), then press **ENTER**.
- 3 Press the **SPACEBAR** until **Alarm History** is selected, then press **ENTER**.
- 4 Press **N** or **P** to page through the alarm history screens.
- 5 Press **L** to clear the selected alarm history screen.

Alarm History at the DS1 Interface

The Alarm History screen reports DS1 statistics for the H2TU-C (Figure 20) and the H2TU-R (Figure 21 on page 41) on a continuous basis. The types of alarms reported are described in Table 17 on page 41. Current alarms are shown in reverse video.

```

Monitor  Performance  Event Log  Config  Inventory  Rlogon  Help
-----
                H2TU-C DS-1 Alarm History
-----
Alarm      First           Last           Status        Count
-----
LLOS      04/10/00 00:00   04/14/00 00:45   ALARM         12
LAIS      04/10/00 00:37   04/14/00 00:45   OK             0
DBER      04/10/00 00:37   04/14/00 00:45   OK             7
-----
                Press: C(l)ear Alarm History
-----
Press <Space> to cycle through  Interface : H2TU-C DS-1
choices and <Enter> to view    Statistics : Alarm History
ID: xxxx--xxxx--xxxx--xxxx    04/15/00 12:30:01   H2TU-C        System: Alarm

```

Figure 20. H2TU-C DS1 Alarm History Screen

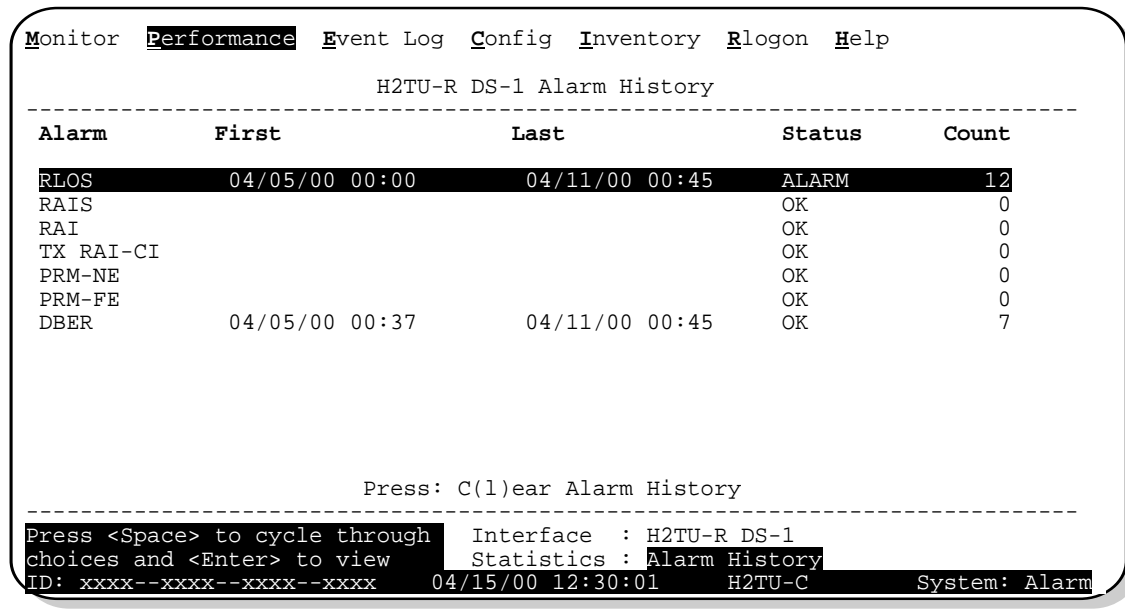

Figure 21. H2TU-R DS1 Alarm History Screen

Table 17. DS1 Alarm Descriptions

Screen Alarm	Front-panel Alarm	Description
H2TU-C DS1 ALARMS (see Figure 20 on page 40)		
LLOS ^(a)	LLOS	Local Loss of Signal—Loss of the H2TU-C DSX-1 input signal.
LAIS	LAIS	Local Alarm Indication Signal—Indicates an AIS (all ones) pattern is being transmitted from the local DS1 output port. The ALMP option determines whether AIS (default) or LOS is sent towards the CPE.
DBER	DBER	Bit Error Rate—The DS1 BER has exceeded the built-in 24-hour threshold limits of approximately 10 ⁻⁶ .
H2TU-R DS1 ALARMS (see Figure 21)		
RLOS ^(a)	RLOS	Remote Loss of Signal— Loss of the H2TU-R DS1 input signal.
RAIS	RAIS	Remote Alarm Indication Signal—Indicates an AIS (all ones) pattern is being received at the H2TU-R DS1 input port. By default (see Figure 24 on page 47) AIS-CI ^(b) is sent towards the network.
RAI	RRAI	Remote RAI - Remote Alarm Indication at the H2TU-R—Indicates an RAI alarm (yellow) from the CPE with errors from the line unit or network.
TX RAI-CI	TRCI	Transmit RAI-CI - Remote Alarm Indication at the H2TU-R—Upon reception of an RAI (yellow alarm) from the CPE, the H2TU-R sends a RAI-CI towards the network if the network signal received at the H2TU-R is clear. If the network signal is impaired (LOS, AIS or LOF), then the RAI is passed on to the network unaltered. This is applicable to SF or ESF framing. In an all SF environment, RACI must be enabled to convert SF RAI to SF RAI-CI.
PRM-NE	PRMN	Performance Report Monitoring - Near End—The count of the PRM-NE register at the H2TU-R exceeds the 10 ⁻⁶ BER threshold at 648 events since 12:00:00 AM.
PRM-FE	PRMF	Performance Report Monitoring - Far End—The count of the PRM-FE register at the H2TU-R exceeds the 10 ⁻⁶ BER threshold at 648 events since 12:00:00 AM.
DBER	DBER	Bit Error Rate—The DS1 BER has exceeded the built-in 24-hour threshold limits of approximately 10 ⁻⁶ .

(a) This is a DS1-specific alarm that also issues a minor alarm (sent to the management unit or the backplane), if enabled.

(b) AIS-CI is a modified AIS alarm pattern. Equipment not suited to detect AIS-CI still detects this signal as an AIS. AIS-CI is sent toward the network indicating that an LOS (RLOS) or AIS (RAIS) has been received from the CPE.

Alarm History at the HDSL2 Interface

Figure 22 shows the H2TU-C HDSL2 alarm history, and Table 18 describes the alarms.

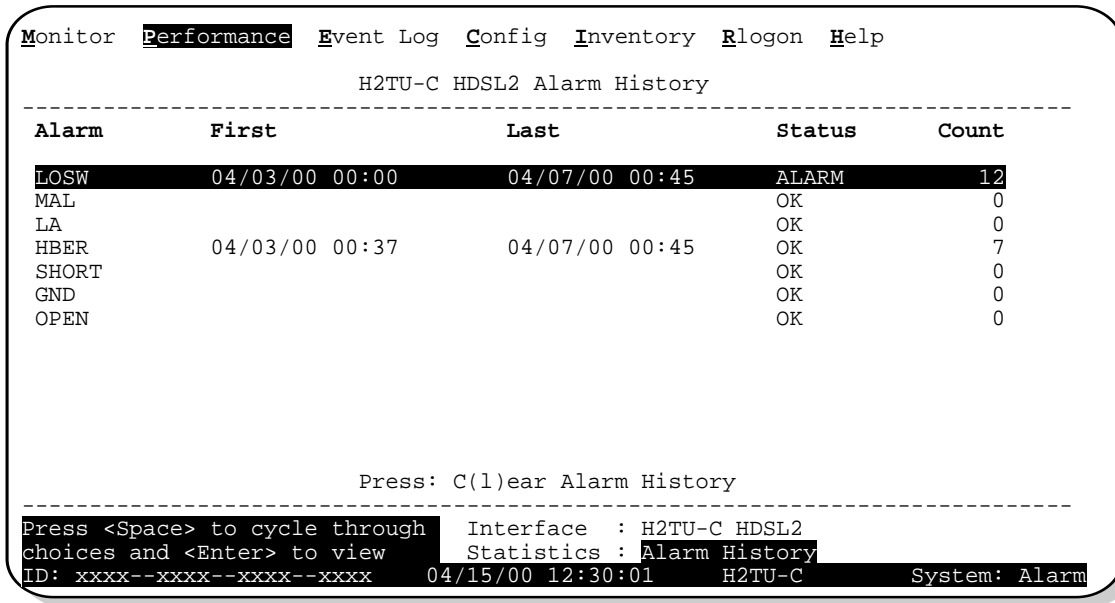

Figure 22. H2TU-C HDSL2 Alarm History Screen

Table 18. HDSL2 Alarm Descriptions

Screen Alarm	Front-panel Alarm	Description
LOSW	LOSW	Loss of Sync Word—The HDSL2 loop has lost synchronization.
MAL	MAL	Margin—The margin on the HDSL2 loop has dropped below the minimum threshold value set for the system.
LA	LA	Loop Attenuation—The attenuation on the HDSL2 loop has exceeded the maximum value set for the HDSL2 loop attenuation threshold.
HBER	HBER	Block Error Rate—The HDSL2 BER has exceeded the set threshold limits of 10 ⁻⁶ or 10 ⁻⁷ .
SHORT ^(a)	SHRT	Indicates a short between the Tip and Ring of the HDSL2 pair.
GND ^(a)	GND	The HDSL2 loop is grounded.
OPEN ^(a)	OPEN	Indicates a line power open condition.

(a) Appears only at the H2TU-C HDSL2 interface.

USING THE EVENT LOG TO TRACK SYSTEM EVENTS

To view a running log of system events, press **E** to select the Event Log. The Event Log displays the date and time of the 100 most recent events (most recent displayed first) and provides a description of each event. See [Table 19 on page 44](#) for a complete list of event log messages.

- Press **N** or **P** to page through the event log.
- Press **T** to return to the top of the log.
- Press **L** to clear the event log.

```

Monitor Performance Event Log Config Inventory Rlogon Help
-----
System Event Log (Page 1 of 7)
-----
# Location Date and Time Entry
1 System 04/10/00 12:25:00 DS1 Alarm Register reset
2 System 04/10/00 12:25:00 HDLSL2 Alarm Register Reset
3 System 04/10/00 12:25:00 DS1 Performance Register Reset
4 System 04/10/00 12:25:00 HDLSL2 Performance Register Reset
5 System 04/10/00 00:13:32 Time set 12:25:00
6 System 04/03/00 00:13:27 Date set 04/03/00
7 H2TU-C 04/03/00 00:13:27 NLOC: Loop-down
8 H2TU-C 04/03/00 00:11:16 NLOC: Loop-up
9 H2TU-R 04/03/00 00:10:43 DS1 LOS Alarm: End
10 H2TU-R 04/03/00 00:10:30 DS1 LOS Alarm: Begin
11 System 04/03/00 00:04:11 DS1C: AUTO to AMI
12 H2TU-C 04/03/00 00:00:40 HDLSL2 LOSW Alarm: End
13 H2TU-C 04/03/00 00:00:02 HDLSL2 LOSW Alarm: Begin
14 - Empty -
15 - Empty -

Press: (N)ext Page, (P)revious Page, (T)op of Log, C(l)ear Log
ID: xxxx--xxxx--xxxx--xxxx 04/15/00 12:30:01 H2TU-C System: OK

```

Figure 23. System Event Log

Table 19. *Event Log Entry Messages List*

Event Log Messages
Any DS1 Alarm History reset
Any DS1 PM register reset
Any HDSL2 Alarm History reset
Any HDSL2 PM register reset
Any Loop Down (any segment)
Any Loop Up (any segment)
Any provisioning option change: <provisioning mnemonic>: changed from <old> to <new>
CPE DBER alarm (1 day threshold crossed of any PM data except PRM-NE or PRM-FE)
CPE DS1 AIS begins / ends
CPE DS1 LOS begins / ends
CPE PRM-NE BER alarm (<i>at the remote only</i> : 1 day threshold crossed of PRM-NE: trouble on CPE receive)
Current statistics reset
Event Log reset
H2TU-R Power up / down
HDSL2 DC pair open begins/ends on any segment
HDSL2 Ground fault begins/ends on any segment
HDSL2 HBER alarm (threshold crossed) on any segment.
HDSL2 loop attenuation (threshold crossed) on any HDSL2 I/F
HDSL2 margin alarm (threshold crossed) on any HDSL2 I/F
HDSL2 unavailability begins / ends on any segment
Master zero reset
NTWK DBER alarm (1day threshold crossed of any PM data)
NTWK DS1 LOS begins / ends
NTWK PRM-FE BER alarm (<i>at the remote only</i> : 1 day threshold crossed of PRM-FE: trouble on NTWK far end)
NTWN DS1 AIS begins / ends
Power Feed Open begins / ends
Power Feed Short begins / ends
RAI begins / ends
TX RAI-CI begins / ends (RAI-CI sent from the remote towards the network)

TESTING

This section provides information about front-panel system alarms, LOS/AIS response, OCT55 test procedure, and loopback testing.

FRONT-PANEL SYSTEM ALARMS

Table 20 summarizes all possible HDSL2 system alarms (7 HDSL2 and 9 DS1) in order of priority as they appear on the front panel. These alarms correlate with the alarms displayed on the alarm history screens (see “Using the Performance Screens to View Alarm Data” beginning on page 40), however, the screens provide a more detailed analysis. More than one alarm condition can exist at any given time, but only one message can be displayed on the front panel. For multiple alarms, only the highest priority alarm displays.

Table 20. *Front-Panel System Alarms Summary*

Front-panel Message ^(a)	Alarm	Description	To Inhibit
PWR FEED SHRT ^(b)	Short	A short exists between the Tip and Ring of the HDSL2 pair.	Cannot be inhibited.
PWR FEED GND ^(b)	Ground	The HDSL2 loop is grounded.	Cannot be inhibited.
PWR FEED OPEN ^(b)	Open	A line power open condition exists.	Cannot be inhibited.
LOSW ^(b)	Loss of Sync Word ^(c)	The HDSL2 loop has lost synchronization.	Cannot be inhibited.
LLOS ^(b)	Local Loss of Signal	Loss of the DSX-1 input signal.	Cannot be inhibited.
RLOS ^(b)	Remote Loss of Signal	Loss of the H2TU-R DS1 input signal.	Cannot be inhibited.
LAIS	Local Alarm Indication Signal	Indicates an AIS (all ones) pattern is being transmitted from the local DS1 output port.	Cannot be inhibited.
RAIS	Remote Alarm Indication Signal	Indicates an AIS (all ones) pattern is being received at the H2TU-R DS1 input port.	Cannot be inhibited.
RRAI	Remote RAI—Remote Alarm Indication at the H2TU-R	Indicates an RAI alarm (yellow) from the CPE with errors from the line unit or network.	Cannot be inhibited.
TRCI	Transmit RAI-CI—Remote Alarm Indication at the H2TU-R	Upon reception of an RAI (yellow alarm) from the CPE, the H2TU-R sends RAI-CI towards the network if the network signal received at the H2TU-R is clear. If the network signal is impaired (LOS, AIS or LOF), then the RAI is passed on to the network unaltered.	Cannot be inhibited.
MAL ^(b)	Margin Alarm	The margin on the HDSL2 loop has dropped below the minimum threshold value set for the system.	Set the Margin Alarm Threshold option to 0 (zero).
LA ^(b)	Loop Attenuation	The attenuation on the HDSL2 loop has exceeded the maximum value set for the HDSL2 loop attenuation threshold.	Set the HDSL2 Loop Attenuation Threshold option to zero.
DBER	DS1 Bit Error Rate	The DS1 BER has exceeded the set threshold limits of approximately 10^{-6} .	Select DIS for the DBER system option.
HBER ^(b)	HDSL2 Block Error Rate	The HDSL2 BER has exceeded the set threshold limits of 10^{-6} or 10^{-7} .	Select NONE for the HBER system option.

Table 20. *Front-Panel System Alarms Summary (Cont.)*

Front-panel Message ^(a)	Alarm	Description	To Inhibit
PRMF	Performance Report Messaging - Far End	Indicates H2TU-R PRM-NE BER threshold is exceeded.	Set DBER threshold to DIS.
PRMN	Performance Report Messaging - Near End	Indicates H2TU-R PRM-NE BER threshold is exceeded.	Set DBER threshold to DIS.

(a) The message, ALRM, displays prior to any alarm message.
(b) Only these alarms assert the System Alarm bus on pins 20 and 21 of the card-edge connector if the ALM option is enabled.
(c) When the HDSL2 loop loses sync word (LOSW), a system alarm condition exists. However, since the H2TU-C-231 enters the acquiring mode, the front-panel status LED flashes red, and the ACQ or SIG message displays instead of the ALRM message.

Alarm Option for Digital Loop Carrier (DLC) Feed

To improve HiGain HDSL2 compatibility with the switch-to-protect features used in DLC feeder applications, the H2TU-C-231 has an Alarm Pattern (ALMP) option that allows you to select either an AIS or LOS DS1 output payload for the following alarms:

- LOSW on any loop
- LOS DS1

Retiring System Alarms

To retire a system alarm, press the SEL button and execute an Alarm Cut Off (ACO). An ACO turns the alarm off and replaces the ALRM message with an ACO message. The second part of the ALRM message, which defines the cause of the alarm, remains. Both parts of the message remain until the alarm condition clears or another higher priority alarm occurs.

Remote LOS and AIS Response

Figure 24 shows the different ways the H2TU-R can respond to the network, depending on the configuration of the TLOS, NLBP, AMLP, FT1, and NAIS configuration options described in Table 5 on page 20 and Table 6 on page 21. See Table 13 on page 28 for response of the H2TU-C and H2TU-R to LOS and AIS alarm conditions.

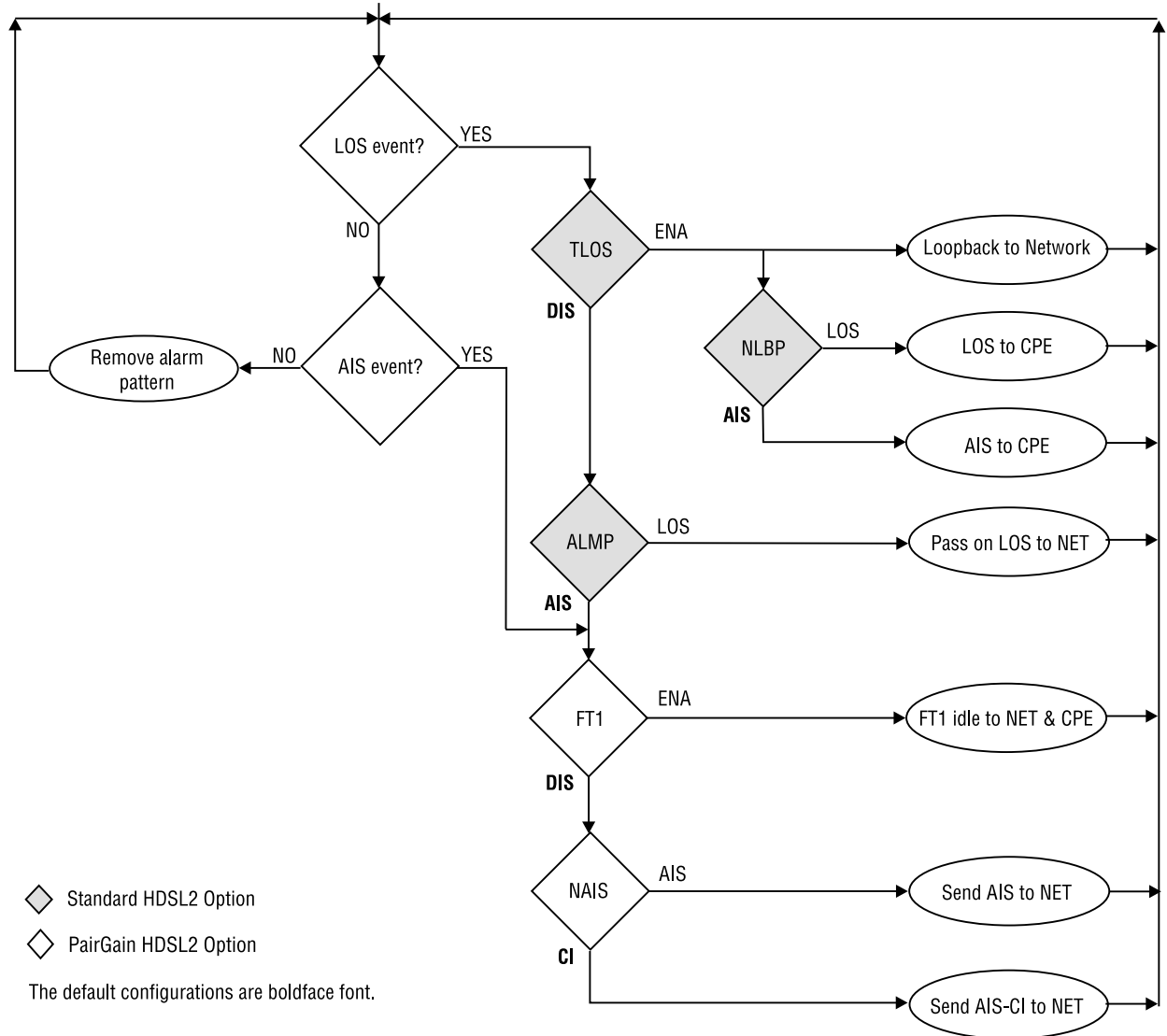

Figure 24. H2TU-R LOS and AIS Response Priorities

OCT55 TEST PATTERN WITH AMI CODE

The OCT 55 test pattern can be used in unframed mode to stress the system and verify data integrity. In an SF or ESF framing mode, excessive zero anomalies may occur which cause the H2TU-C to report ES, SES, and UAS errors according to ANSI T1.231-1997.

LOOPBACK OPERATION

HiGain HDSL2 has a family of loopback options for analyzing circuit functionality. The loopback signal is transmitted and returned to the sending device for comparison. This allows you to verify the integrity of the HDSL2 channels to the H2TU-C, the H2TU-C DSX-1 interface, and the DS1 channels to the customer. Loopback options include:

- Generic Loopback (GNLB) options, including the SmartJack (SMJK) option (see [Table 21 on page 49](#))
- Special Loopback (SPLB) options (see [“Special Loopback Commands” on page 50](#)) and the following command tables:
 - Addressable Repeater Loopback command: A2LB (see [Table 22 on page 54](#))
 - Addressable Repeater Loopback commands: A3LB, A4LB (see [Table 23 on page 57](#))

Loopback commands can be initiated by:

- Selecting the loopback type using the MODE and SEL buttons on the H2TU-C front panel (or the Manual Loopback button on the H2TU-R)
- Selecting the loopback type from the Monitor menu when connected to the craft port of the H2TU-C or H2TU-R
- Entering the loopback code into the test equipment connected to the H2TU-C or H2TU-R



HiGain HDSL2 only supports one active loopback; however, SmartJack loopback can be present along with one other network loopback.

Generic Loopback Commands

The HiGain HDSL2 Generic Loopback (GNLB) commands allow you to use inband codes to loop up either NLOC (4-in-7) or NREM (3-in-7) towards the network. In addition, these inband codes loop up CREM (6-in-7) or CLOC (5-in-7) towards the customer. Either loopup condition can be terminated (looped down) with the 3-in-5, SMJK loopdown code. All inband codes must be present for at least 5 seconds before the HiGain HDSL2 system responds. HiGain HDSL2 also supports NRGx regenerator loopbacks to the network and CRGx regenerator loopbacks towards the customer. TLOS is a logic loopback caused by loss of the DS1 input from the CI.

[Figure 25](#) summarizes the available loopbacks in the system, and [Table 21 on page 49](#) summarizes the HiGain HDSL2 generic loopback commands. See [“GNLB Test Procedures” on page 52](#) for the test procedures that apply when using the GNLB mode.

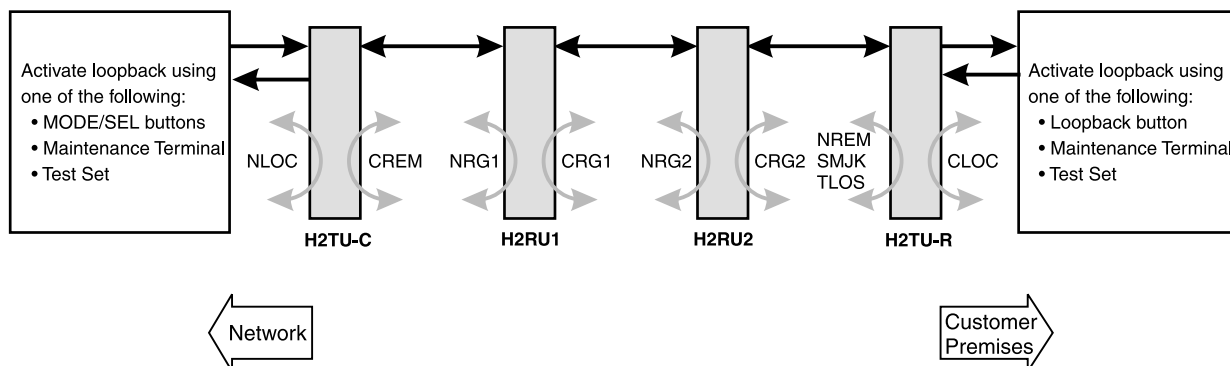

Figure 25. Loopback Summary

Table 21. Summary of HiGain HDSL2 Loopback Codes and Activation Methods

Loopback	Code	Description	Method of Activation		
			Test Set	Craft Port	MODE/SEL
NLOC	1111000 4-in-7	DSX-1 signal is looped back to the network at the H2TU-C.	X	X	X
NRG1	110000 2-in-6	DSX-1 signal is looped back to the network at the regenerator 1.	X	X	X
NRG2	111000 3-in-6	DSX-1 signal is looped back to the network at the regenerator 2.	X	X	X
NREM	1110000 3-in-7	DSX-1 signal is looped back to the network at the H2TU-R.	X	X	X
CLOC	1111100 5-in-7	Signal from the customer is looped back to the customer at the H2TU-R.	X	X	X
CRG1	111100 4-in-6	Signal from the customer is looped back to the customer at regenerator 1.	X	X	X
CRG2	111110 5-in-6	Signal from the customer is looped back to the customer at regenerator 2.	X	X	X
CREM	1111110 6-in-7	Signal from the customer is looped back to the customer at the H2TU-C.	X	X	X
SMJK LpUp (PL)	11000 2-in-5	SmartJack Loopup or NID payload (PL) code. Invokes H2TU-R loopback towards network.	X		
SMJK LpUp (ESF-DL)	1111-1111- 0100-1000	SmartJack Loopup or NID (ESF-DL) code. Invokes H2TU-R loopback towards network.	X		
SMJK LpDn (PL)	11100 3-in-5	SmartJack Loopedown or NID payload (PL) code. Removes SMJK, NLOC, NREM, CLOC, CREM, CRG _x , and NRG _x .	X		
SMJK LpDn (ESF-DL)	1111-1111- 0010-0100	SmartJack Loopedown or NID (ESF-DL) code. Removes SMJK, NLOC, NREM, CLOC, CREM, CRG _x , and NRG _x .	X		



HiGain HDSL2 systems feature the SmartJack option which can emulate a Network Interface Device (NID) for the purpose of loopback testing of the HiGain HDSL2 circuit. SMJK and NREM loopbacks perform the same functions, but their initiation differs. SMJK indicates that the loopback was initiated by the 2-in-5 inband command. NREM, on the other hand, is initiated by the 3-in-7 inband command or by a command issued from the maintenance terminal or the MODE and SEL buttons.

Use the inband commands to enable or disable the SMJK loopback options. The H2TU-C-231 system setting is normally enabled to recognize all inband SmartJack loopback commands.

Special Loopback Commands

In addition to the GNLB loopback command mode, a HiGain HDSL2 system can be configured for one of three special loopback command modes. These are selected from the maintenance terminal System Settings screen (see [Table 6 on page 21](#)) or by using the MODE and SEL buttons (see [Figure 26 on page 53](#)). Once a loopback mode is activated, other loopback commands can be sent by a test set connected to the craft port of the H2TU-C or H2TU-R (see [Table 22 on page 54](#) and [Table 23 on page 57](#) for list of SPLB commands).

A2LB through A4LB are special, addressable, repeater loopback modes that are supported by the H2TU-C-231. These loopback modes provide the HiGain HDSL2 system with sophisticated maintenance and troubleshooting tools. A2LB is patterned after the Teltrend addressable T1 repeater loopbacks. A3LB and A4LB are patterned after the Wescom addressable T1 repeater loopbacks.

All three SPLBs have been enhanced to handle the specific requirements of the following HiGain HDSL2 customers:

- A2LB (Teltrend) = Southwestern Bell
- A3LB (Wescom) = New England Telephone, Bell Atlantic
- A4LB (Wescom Mod 1) = New York Telephone

A2LB can be configured to do one of the following:

- Block the arming code (after 2 seconds) from exiting the H2TU-C into the network, and replace it with the AIS code.
- Unblock the AIS code by executing the Far End Activate code.

A3LB differs from A4LB in that A3LB supports the additional (1-in-6) SMJK loopback command.

Manual Loopback Session

A manual loopback session allows you to select any one of the HiGain HDSL2 loopbacks listed in [Table 21 on page 49](#) with the exception of SmartJack loopbacks, which can only be issued by inband commands.

Setting the Loopback Time-out Option

Before initiating a loopback session, verify that the Loopback Time-out parameter is set to the desired setting.

- 1 Use the MODE and SEL buttons as described in “[Setting Options through MODE and SEL](#)” on page 12.
(The Loopback Time-out parameter is also user-selectable from the System Settings screen when using a maintenance terminal.)
- 2 Select the desired setting:
 - NONE (time-out disabled)
 - 20 minutes
 - 60 minutes
 - 120 minutes (default setting)

Activating Manual Loopback Mode



With the exception of SmartJack, any of the HiGain HDSL2 loopbacks can be executed using the MODE and SEL buttons.

When executing a manual loopback session using the MODE and SEL buttons:

- **The next loopback option can be displayed by pressing the MODE button, however, the previously activated loopback remains active until the SEL button is pressed, which activates the new loopback.**
- **If neither button is pressed for a period of 30 seconds and no loopback is in effect, the manual loopback session terminates and the display returns to normal mode.**
- **If any loopback is in effect, the 30-second time-out is inhibited. The active loopback and the manual loopback session continue until the loopback times out in accordance with the LBTO setting.**
- **Only the SMJK loopback can exist with other network loopbacks at any given time.**
- **If there is an active loopback, pressing the MODE and SEL buttons for 3 or more seconds terminates any active loopback, ends the manual loopback session, and returns the display to normal mode.**

To initiate a manual loopback session:

- 1 Press both the MODE and SEL buttons on the front panel for at least 3 seconds. The following message appears on the front-panel display:
MAN LPBK NLO?
- 2 Press SEL to activate NLOC. The display changes to MAN LPBK NLOC.
- 3 Press MODE to advance to the next available loopback (CRE?, NRE?, CLO?, NR1?, CR1?, NR2?, CR2?).
- 4 Press SEL to activate the selected loopback. The previous loopback is terminated.

Once a loopback is selected and activated, the loopback stays active until it times out (based on the LBTO setting). When a loopback times out, the display then returns to the normal display mode.

You can terminate loopbacks manually and exit the MAN LPBK mode by simultaneously pressing the MODE and SEL buttons for 3 or more seconds. If no loopback is active, the MAN LPBK mode automatically terminates after 30 seconds.

All loopbacks can be initiated by inband commands in the DS1 payload or by a command from the HiGain HDSL2 system (front-panel buttons or maintenance screen selections). Therefore, whenever a loopback is active, the method by which it was activated is indicated in the Loopback and Status screens by the annotation HG or PL adjacent to the identified loopback. For example, NREM-HG indicates that the loopback was initiated by the HiGain HDSL2 system.



SMJK loopback commands are only activated by inband commands.

LOOPBACK TEST PROCEDURES

The following sections provide step-by-step test procedures for verifying the integrity of the HDSL2 channels at every module location as well as the DS1 channels to the customer and the local DSX-1 interface.

General Troubleshooting Tips

If trouble is encountered on the DSX-1 interface of the H2TU-C, verify that the:

- H2TU-C is making a positive connection with its mounting-assembly (shelf) connector.
- H2TU-C internal equalizer is set to the correct distance range per [Table 6 on page 21](#). All equalizers should be set to the distance from the DSX-1 to the shelf.

The transmit and receive DS1 DSX-1 ports have splitting access jacks and miniature, 210-series, bridging jacks as shown in [Figure 2 on page 4](#). Connecting one cable between the two bridging jacks and another between the two SPAN jacks splits the IN and OUT and creates metallic loopbacks towards both the DSX-1 and the H2TU-C-231. If separate plugs are inserted into both SPAN jacks with the other end disconnected, the BRG jacks can be used to send and receive test patterns towards the DSX-1.

GNLB Test Procedures

[Figure 26 on page 53](#) is a graphical representation of the various loopback configurations with the associated GNLB commands shown. Also, refer to [Table 21 on page 49](#) for a description of these commands.

To perform the GNLB loopback test procedure:

- 1 Have the CO tester send the NREM (3-in-7) inband loopup code for 5 seconds. You should be able to observe the NREM message on the front-panel display. (The Status LED on the front panel should be green, and the loopback mode should also be identified on the Span Status screen.)
- 2 Have the CO tester transmit a DS1 test signal towards the H2TU-C and verify that the returned (looped) signal to the test set is error-free.
- 3 If step 2 fails, have the CO tester transmit the 3-in-5 inband loopdown code.
- 4 Have the CO tester send the NLOC (4-in-7) inband loopup for 5 seconds. You should be able to observe the NLOC message on the front-panel display. (The Status LED on the front panel should be yellow, and the loopback mode should also be identified on the Span Status screen.)
- 5 Repeat Step 2. If the test passes, the problem is in the downstream direction. If it fails, the problem is in the upstream direction.

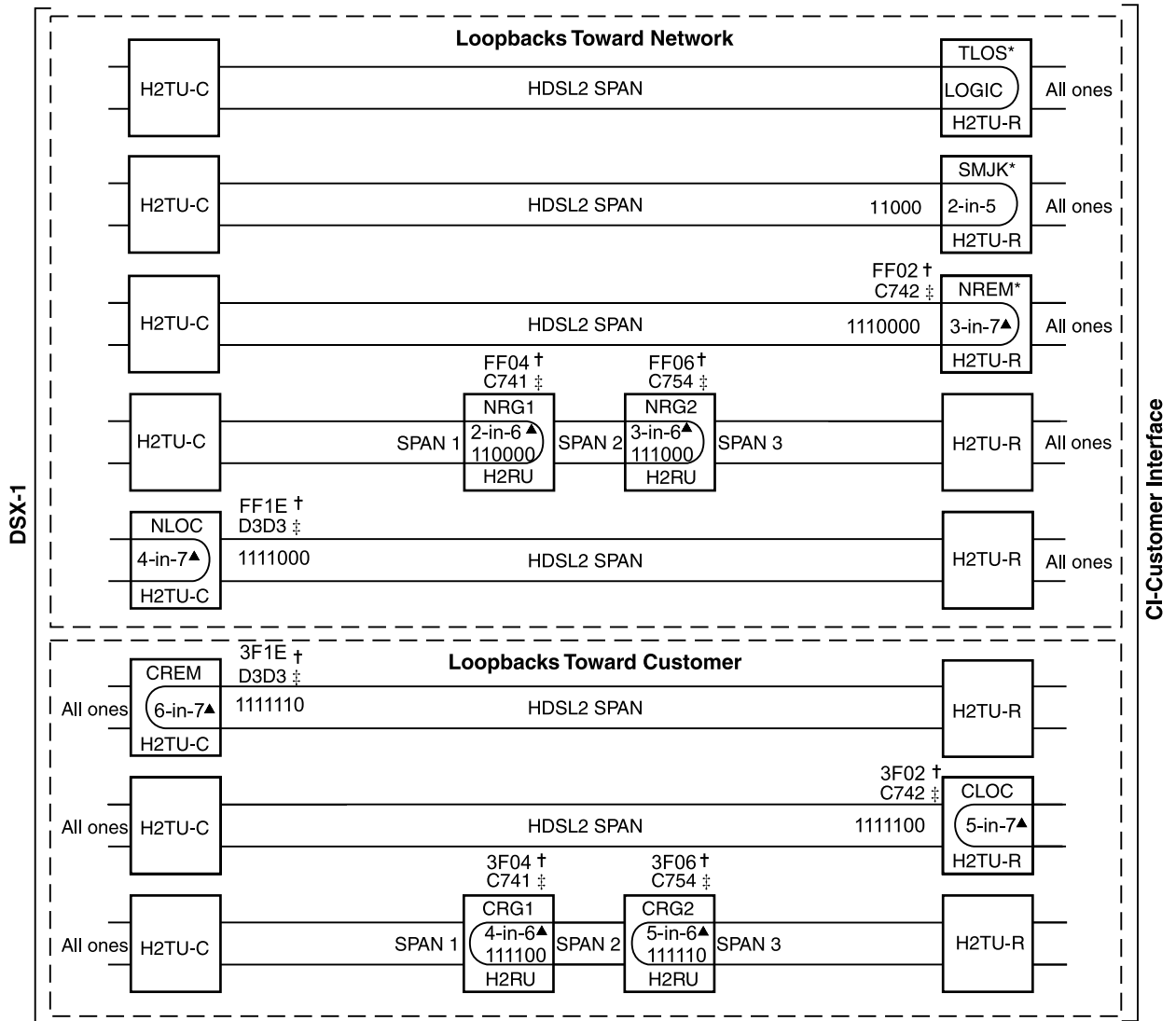

* Set the NLBP option to AIS to send AIS (indicated by an all ones pattern) for any network loopback.

† A3LB and A4LB loopback codes.

‡ A2LB loopback codes.

▲ GNLB loopback codes.

Figure 26. Loopback Modes

A2LB Test Procedures

Using the codes listed in [Table 22](#), a network tester can activate NLOC, NRG or NREM loopbacks (or SMJK, if enabled). A tester at the customer premises can activate CLOC, CRG, or CREM loopbacks. All loopbacks shown in [Table 22](#) can also be initiated from the H2TU-C front-panel MODE and SEL buttons (see “[Setting Options through MODE and SEL](#)” on page 12). Information specific to HiGain HDSL2 regenerators is shown in bold type.

Table 22. *Addressable Repeater Loopback Commands (A2LB)*

Name	Description	Binary Code ^(a) (Hexadecimal Equivalent)
ARMING or NI LPBK (inband)	Arming code	11000-11000 ...
ARMING or NI LPBK (ESF Datalink)	Arming code	1111-1111-0100-1000 (FF48)
IR LPDN or DISARM (inband)	Disarming code	11100-11100 ...
IR LPDN or DISARM (ESF Datalink)	Disarming code	1111-1111-0010-0100 (FF24)
IOR LPBK (NLOC and CREM) 230-232 bit errors 229-231 bit errors ^(b)	H2TU-C loopup	1101-0011-1101-0011 (D3D3)
ILR-1 LPBK (NRG1 and CRG1 10 bit errors)^(b)	Regenerator-1 loopup	1100-0111-0100-0001 (C741)
ILR-20 LPBK (NRG2 and CRG2 200 bit errors)	Regenerator-2 loopup	1100-0111-0101-0100 (C754)
ILR-2 LPBK (NREM and CLOC 20 bit errors)	H2TU-R loopup	1100-0111-0100-0010 (C742)
IR LPDN	Loopdown (H2TU-C, H2RU, or H2TU-R)	1001-0011-1001-0011 (9393)
IR QUERY LPBK	Query loopback	1101-0101-1101-0101 (D5D5)
IR ALTERNATE QUERY LPBK	Alternate query loopback	1101-0101-1110-1010 (D5EA)
TIME-OUT OVERRIDE	Loopback time-out override	1101-0101-1101-0110 (D5D6)
FAR END NI ACTIVATE	Unblock AIS	1100-0101-0101-0100 (C554)
IOR POWER DOWN (H2TU-C) ^(c)	Removes HDSL2 line power	0110-0111-0110-0111 (6767)

- (a) The leftmost bit arrives first in all sequences. The detection algorithm functions reliably with a random 10^{-3} BER on the facility. The entire arming and loopback sequence can also be initiated at the remote H2TU-R location.
- (b) The H2TU-R identifies CREM (and the H2TU-C identifies NLOC) with 231 bit errors, including the frame bits. When framed data is being sent in the Auto framing mode, the number of the 231 bit errors detected by the test set varies from 229 to 231, depending on whether or not the test set counts frame errors as bit errors and on the number of frame bits contained in the block of 231 error bits. The H2TU-R and H2TU-C generate this bit pattern in a series of discontinuous bursts containing 20-bit errors each, including frame bits. Those test sets that do not count frame error bits as data bit errors will indicate fewer bits than the H2TU-R and H2TU-C transmit for a CI and NI loopback.
- (c) The IOR Power Down code must remain present for the duration of the powerdown mode. When this code is removed, the HiGain HDSL2 system returns to its normal unlooped and unarmed state.

To perform the A2LB test procedures:

- 1 Send the inband Arming and NI LPBK code 11000 to the H2TU-C for at least 5 seconds.
- 2 Monitor the output of the H2TU-C for the return of the pattern. Return of the pattern indicates one of the following:
 - The H2TU-R has looped up (if the SMJK Loopback option is enabled)
 - An external NID has looped up (if the SMJK Loopback option is disabled), and the H2TU-C and H2TU-R have been armed.
- 3 Verify, if possible, that the H2TU-R Loopback LED is either flashing yellow at 4-second intervals (indicating that the system is armed), or is a steady yellow (indicating that it is both armed and in SMJK loopback). The H2TU-C Status LED also flashes yellow when the system is armed.



If the Arming code is not returned after 5 seconds, the system may be armed but there is no active loopback.

- 4 Once armed, the H2TU-C can be looped back by sending Intelligent Office Repeater (IOR) LPBK activation code 1101-0011-1101-0011 (D3D3) for at least 5 seconds. You should observe the following activation response pattern:
 - a 2 seconds of AIS (all ones pattern)
 - b 2 seconds of returning data pattern
 - c 231 logic errors (including the frame bit) occurring in the returned pattern comprising:
 - 10 errors, if ILR-1 (Regenerator 1) was sent
 - 200 errors, if ILR-20 (Regenerator 2) was sent
 - 20 errors, if ILR-2 (H2TU-R) was sent
 - d Normal looped data

This error pattern repeats every 20 seconds as long as the IOR loopback pattern is being sent. This also applies to ILR, Time-out Override, and Query commands.



Some Intelligent Repeater (IR) test sets do not count frame errors as bit errors when the test pattern is framed and the H2TU-C-231 is set to the Auto framing mode. To improve compatibility with those test sets, the H2TU-C generates 200 (NRG2 and CRG2) and 231 (NLOC and CREM) ID bit errors. As a result, the H2TU-C may indicate one more or one less bit error, depending on the test set type and the number of frame bits contained in the block of errored bits. To avoid this uncertainty, ADC recommends sending unframed IR commands.

The H2TU-C is now in logic loopback if the IOR NLOC loopback command was sent. The Time-out Override command or a Loopdown command can override the selection made for the loopback time-out (see [“Setting the Loopback Time-out Option” on page 51](#)). If the Time-out Override code 1101-0101-1101-0110 (D5D6) is received after activating a loopback, then the automatic timed expiration of the loopback is inhibited. If this Time-out Override is sent, then the only way to loop the H2TU-C down is to do one of the following:

- Issue the IR loopdown (LPDN) code 1001-0011-1001-0011 (9393)
- Issue the NI LPDN and Disarm inband code 11100 or the ESF-DL code (FF24).



The Time-out Override function is only valid for the current active loopback. The automatic time-out timer is restored during subsequent loopback sessions.

5 Once the test is complete, do one of the following:

- If the system is to loop down but remain Armed, send the IR LPDN code.
- If all the equipment is to be looped down, disarmed, and returned to normal operation, send the disarm inband code 11100 or the ESF-DL code (FF24).



The Armed mode has an automatic time-out of 120 minutes but this timer is reset to 120 for any of the following events:

- **Loopback terminates (manually or time-out)**
- **Query**
- **Alternate query**
- **Far End activate**
- **Another ARM command**

This timer is inhibited while any of the valid command codes are being sent. Once the codes are removed, the timer restarts at 120.

A3LB and A4LB Test Procedures

The H2TU-C-231 can be looped back by sending the Addressable Office Repeater (AOR) LPBK activation code 1111-1111-0001-1110 (FF1E) for at least 5 seconds. This causes the H2TU-C to enter the NLOC state. The Loopback Time-out setting (see “[Setting the Loopback Time-out Option](#)” on page 51) determines the duration of this loopback unless it is overridden by the reception of a second identical 16-bit loopup command before the timer expires. When this time-out override state exists, the only way to loop the H2TU-C down is to issue one of the three loopdown commands listed in [Table 23](#). The automatic time-out mode is restored during subsequent loopback sessions.

[Table 23](#) summarizes the codes required to execute Addressable 3 (A3LB) and Addressable 4 (A4LB) repeater loopback commands. All code sequences must be present for at least 5 seconds. Information specific to HiGain HDSL2 regenerators is shown in bold.

Table 23. Addressable Repeater Loopback Commands (A3LB and A4LB)

Name	Description	Binary Code ^(a) (Hexadecimal Equivalent)
NLOC	H2TU-C loopup from NI	1111-1111-0001-1110 (FF1E)
CREM	H2TU-C loopup from CI	0011-1111-0001-1110 (3F1E)
NRG1	H2RU regenerator 1 loopup from NI	1111-1111-0000-0100 (FF04)
CRG1	H2RU regenerator 1 loopup from CI	0011-1111-0000-0100 (3F04)
NRG2	H2RU regenerator 2 loopup from NI	1111-1111-0000-0110 (FF06)
CRG2	H2RU regenerator 2 loopup from CI	0011-1111-0000-0110 (3F06)
NREM	H2TU-R loopup from NI	1111-1111-0000-0010 (FF02)
CLOC	H2TU-R loopup from CI	0011-1111-0000-0010 (3F02)
SMJK	H2TU-R loopup from NI	11000-11000-11000 ...
SMJK	H2TU-R loopup from NI ^(b)	100000 100000 100000 ...
SMJK	H2TU-R loopup from NI (ESF-DL)	1111-1111-0100-1000 (FF48)
Loopdown	H2TU-C and H2TU-R loopdown from NI OR CI	11100-11100-11100 ...
Loopdown	H2TU-C and H2TU-R loopdown from NI OR CI	100-100-100 ...
Loopdown	H2TU-C and H2TU-R loopdown from NI OR CI (ESF-DL)	1111-1111-0010-0100 (FF24)

(a) The leftmost bit arrives first in all sequences. The detection algorithm functions reliably with a random 10^{-3} Bit Error Ratio (BER) on the facility. The entire arming and loopback sequence can also be initiated at the remote H2TU-R location.

(b) Not supported by A4LB.

APPENDIX A - SPECIFICATIONS

Power

HDSL2 Span Voltage	0 or -185 Vdc
CO Supply	-48 Vdc nominal (-42.5 to -56.5 Vdc) (See "Power Consumption", "Maximum Power Dissipation", and "Maximum Current Drain" on page 59.)
Electrical Protection	Secondary surge and power cross-protection on HDSL2 ports. Requires external primary protection.
Fusing	Internal; connected to "FUSE ALARM" output on pin 32

Environmental

Operating Temperature	-40 °F to +149 °F (-40 °C to +65 °C)
Operating Humidity	5% to 95% (non-condensing)

Physical

Height	5.9 in. (15.0 cm)
Width	1.4 in. (3.5 cm)
Depth	10.0 in. (25.4 cm)
Weight	8.0 oz. (0.23 kg)
Mounting	220 mechanics

HDSL2

Line Rate	1.552 Mbps Overlapped Pulse Amplitude Modulation Transmission with Interlocking Spectra (OPTIS)
Transmission	Full duplex
Media	One non-loaded, copper, two-wire cable pair
Output	+16.8 dBm \pm 0.5 dB at 135 Ω (0-450 kHz) at CO side; +16.5 dBm \pm 0.5 dB at 135 Ω (0-350 kHz) at remote side
Line Impedance	135 Ω
Maximum Loop Attenuation	35 dB at 196 kHz, 135 Ω
Start-up Time	30 sec. (typical), 1 min. (maximum) per span

DSX-1

DSX-1 Line Impedance	100 Ω
DSX-1 Line Rate	1.544 Mbps \pm 200 bps
DSX-1 Line Format	Alternate Mark Inversion (AMI) or Bipolar with 8-Zero Substitution (B8ZS)
DSX-1 Frame Format	Extended SuperFrame (ESF), SuperFrame (SF), or Unframed (UNFR)
DSX-1 Pulse Output	6 V ^{pk-pk} pre-equalized for 0 to 655 feet of ABAM cable
DSX-1 Input Level	+1.5 to -7.5 dB DSX

System

One-way DS1 Delay	<400 μ s per span without regenerators
Wander (Looped)	Meets MTIE T1.101 requirements
Wideband Jitter (Looped)	0.2 UI maximum
Narrowband Jitter (Looped)	0.1 UI maximum

POWER CONSUMPTION

The maximum power consumption and heat dissipation depends upon the type of remote and regenerator units in the system and the CPE power setting.

The three most important power parameters of an H2TU-C are its maximum power consumption, maximum power dissipation, and maximum current drain.

Table 24 describes line-powered circuits on 9 kft, 26 AWG loops without a regenerator.

Table 24. H2TU-C Power Parameters—No Regenerator

H2TU-R Model No.	H2TU-R CPE Power	-42.5 Vdc Power Consumption (Watts)		Heat Dissipation (Watts)		-42.5 Vdc Current (mA)	
		Typical	Maximum	Typical	Maximum	Typical	Maximum
H2TU-R-402		11.5	12.5	6.0	7.0	270.0	294.0

MAXIMUM POWER DISSIPATION

The maximum power dissipation measures the power that is converted into heat that builds up within the unit. It contributes to the total heat generated in the space around the unit. It is used to determine the maximum number of fully loaded shelves per bay that does not exceed the maximum allowable power dissipation density in watts per square foot to comply with GR-63.

In COs, the maximum power dissipation for open-faced, natural convection-cooled mountings is limited to 134.7 watts per square foot per GR-63-CORE. The footprint of a standard 28-slot, 23-inch HCS-417 shelf is 7.024 square feet. Therefore, the maximum bay dissipation is limited to 946 watts. Use this limit and the parameters in Table 24 to determine the maximum number of H2TU-C circuits that can occupy one CO bay.



This is a worst case situation since it assumes the entire CO is subjected to the maximum power density. More favorable conditions would permit increasing the number of shelves per bay without jeopardizing the CO thermal integrity.

The thermal loading limitations imposed when using the H2TU-C in a Controlled Environmental Vault (CEV) or other enclosures are determined by applying its power parameters to the manufacturer's requirements for each specific housing.

The -42.5 Vdc power consumption is the maximum total power that the H2TU-C consumes or draws from the shelf power source. This parameter is needed when the H2TU-C is in a location remote to the CO it is serving. It determines the battery capacity required to maintain an 8-hour, standby battery reserve for emergency situations. Battery capacity, therefore, limits the maximum number of line units which can be installed in a remote enclosure. Use the data in Table 24 to perform this analysis.

MAXIMUM CURRENT DRAIN

The maximum current drain is the maximum current drawn from the shelf power supply when its at its minimum voltage (-42.5 Vdc). This determines the shelf fusing requirements. Use the -42.5 Vdc current data in Table 24 to determine the shelf fusing requirements for your particular H2TU-C applications.

H2TU-C-231 LIST 1E CARD CONNECTOR

Figure 27 shows the card-edge connectors on the H2TU-C-231 List 1E. Active pins are highlighted in black.

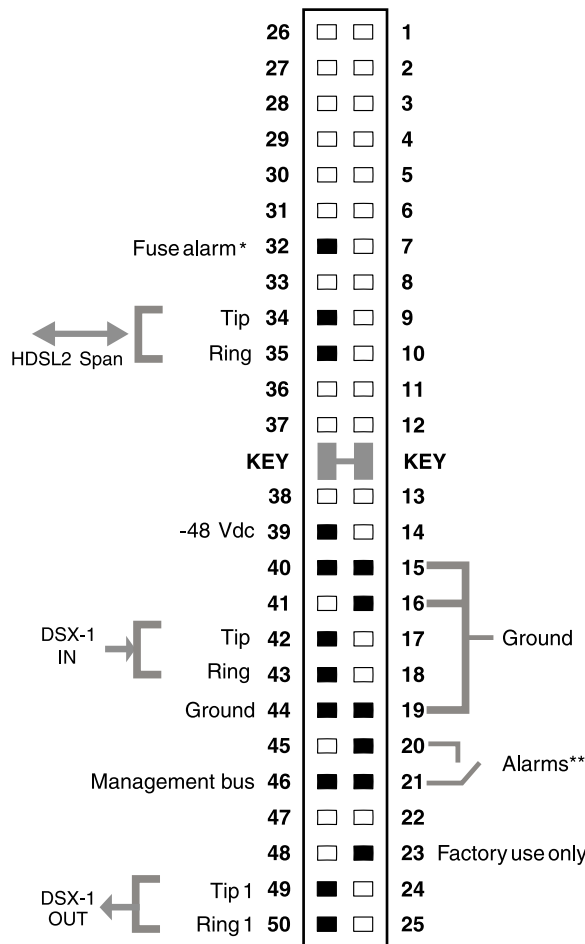

* Fuse alarm is normally floating and at -48 Vdc when activated.
 ** System minor alarm contacts (pins 20 and 21) are normally open, and close upon alarm.

Figure 27. H2TU-C-231 List 1E Card-edge Connector

Network Management Control Bus

The H2TU-C provides a Network Management Control Bus on pin 46 of the card-edge connector. This allows the various ADC Management System protocols to manage the H2TU-C through the H2TU-319 HiGain Management Unit. Whenever the H2TU-C is under management, the MNGD message displays periodically on the front-panel display.



Some H2TU-C-231 List 1E features are affected when it is under management. Consult the management unit practice for further information (see “Appendix D - Product Support” on page 65).

Fuse Alarm

Pin 32 on the card-edge connector is a fuse alarm that is driven to -48 Vdc through a diode whenever the onboard fuse opens.

System Alarm Output Pins

Pins 20 and 21 on the card-edge connector (see [Figure 27 on page 60](#)) are the H2TU-C-231 System Alarm output relay contacts. The following notes apply to pins 20 and 21:

- The H2TU-C Status LED flashes red for the duration of a system alarm condition.
- Setting the ALM option to DIS only prevents the system alarm relay pins 20 and 21 closing for a system alarm event. The Status LED still flashes red and the ALRM message still displays.

CRAFT PORT

[Figure 28](#) shows the pinout for the craft port connector and its connection to a DB-9 or DB-25 connector on a maintenance terminal.

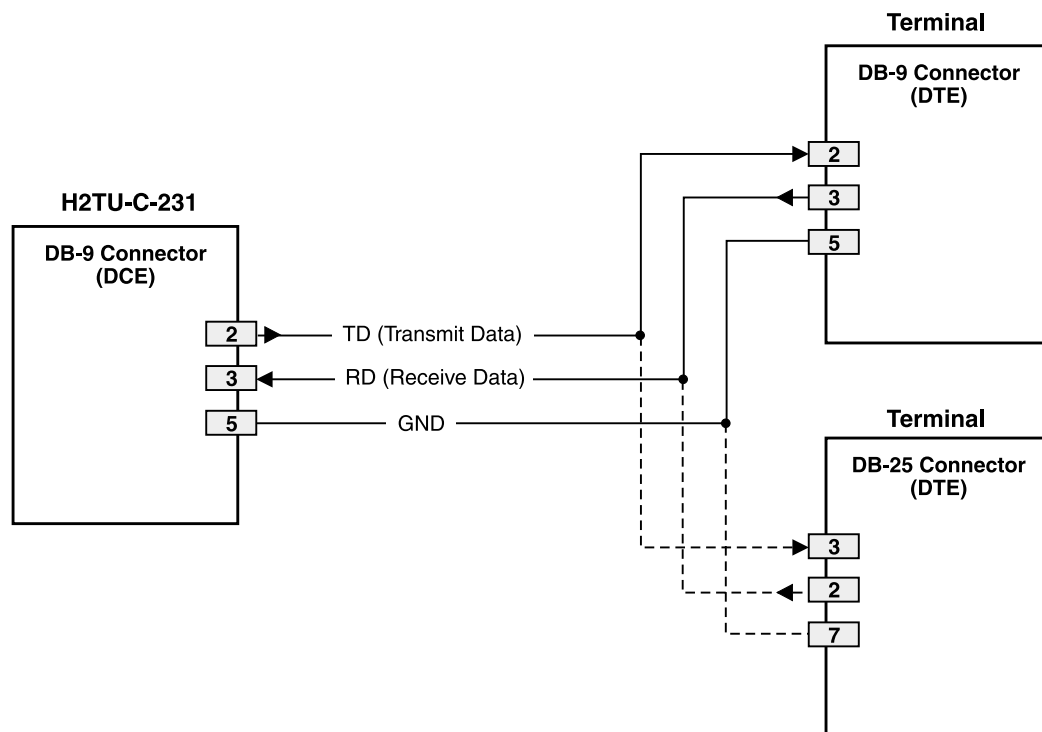

Figure 28. RS-232 Craft Port Pinouts

APPENDIX B - FUNCTIONAL OPERATION

ADC HDSL2 technology provides full-duplex services at standard DS1 rates over copper wires between an H2TU-C and an H2TU-R, which comprise one HiGain HDSL2 system. HiGain HDSL2 systems use ADC Overlapped Pulse Amplitude Modulation (PAM) Transmission with Interlocking Spectra (OPTIS) transceiver systems to establish full-duplex, 1.552 kbps data channels between the H2TU-C-231 and a remotely located H2TU-R.

A block diagram of the H2TU-C-231 is shown in Figure 29. The H2TU-C-231 receives a 1.544 Mbps DSX-1 data stream from the DSX-1 digital cross connect interface. The H2TU-C contains a DS1 frame synchronizer controlled by an 8-bit microprocessor that determines the type of framing on the DS1 stream and synchronizes to it. The H2TU-C recognizes Superframe (SF) or Extended Superframe (ESF) framing. When the data is unframed, the H2TU-C arbitrarily defines a frame bit.

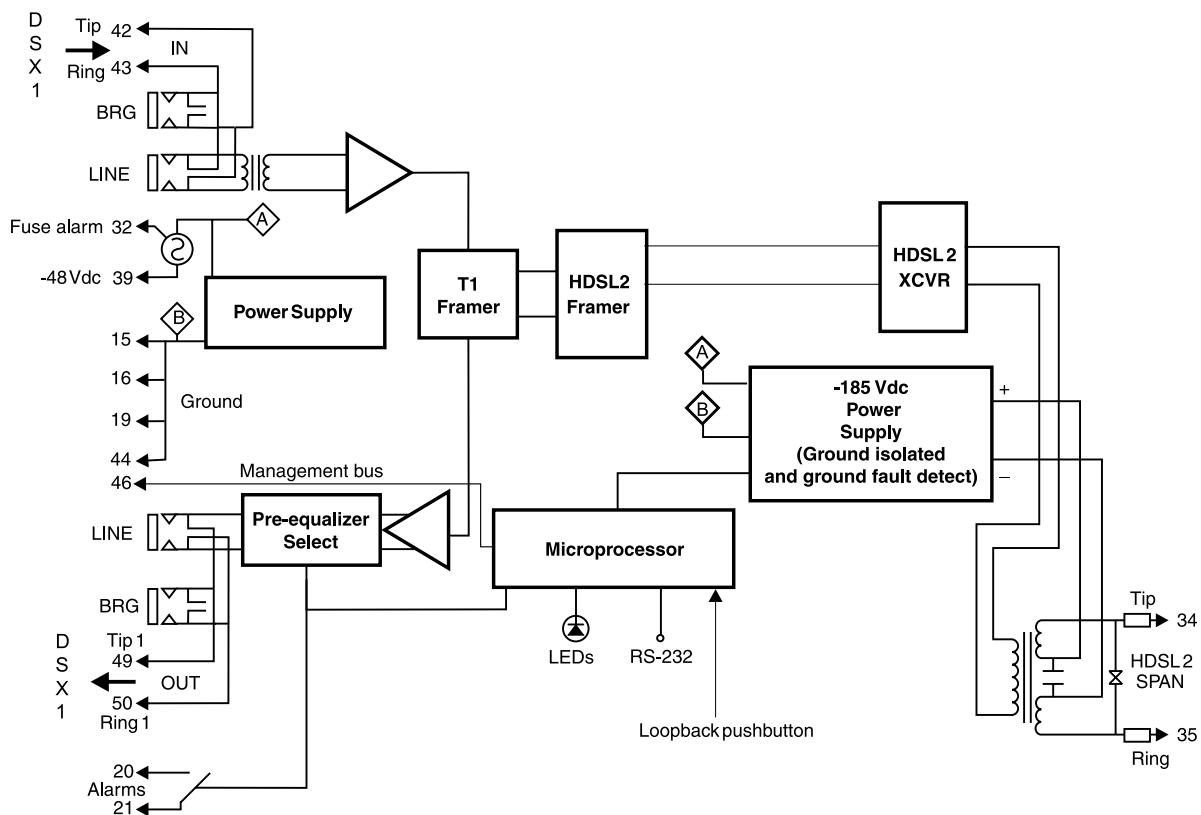

Figure 29. H2TU-C-231 List 1E Block Diagram

TIMING

The low-loop wander (0.3 UI max) of an H2TU-C, when used with compatible regenerators and remote units, allows the circuit to be used in all critical timing applications, including those that are used to transport Stratum 1 timing.

GROUND FAULT DETECT

The H2TU-C has a Ground Fault Detect (GFD) circuit which detects a ground or a resistive path to ground on any wire of the HDSL2 loop. This makes the product compliant with the Class A2 requirements of GR-1089.

APPENDIX C - COMPATIBILITY

The HiGain HDSL2 system uses HDSL2 transmission technology as recommended by Bellcore TA-TSY-001210. HiGain HDSL2 complies with GR-63-CORE, TR-TSY-000499, and GR-1089-CORE.

The H2TU-C-231 List 1E is compatible with the following T1 repeater shelves and associated equipment:

- ADC HCS-417 (23" shelf)
- ADC HCS-418 (19" shelf)
- ADC HCS-402 (2-slot)
- AT&T 220 Office Repeater Bay (ORB)
- AT&T Small Cross-section Shelf (SXSS)
- Kentrox 220 (The ALM option must be disabled [DIS] to resolve a conflict between the H2TU-C alarm relay output and the Kentrox external equalizer output. Both use pins 20 and 21.)
- Wescom® 342-30

APPENDIX D - PRODUCT SUPPORT

ADC Customer Service Group provides expert pre-sales and post-sales support and training for all its products.

Technical support is available 24 hours a day, 7 days a week by contacting the ADC Technical Assistance Center (TAC).

Sales Assistance 800.366.3891 extension 73000 (USA and Canada) 952.917.3000 Fax: 952.917.3237	<ul style="list-style-type: none"> • Quotation Proposals • Ordering and Delivery • General Product Information
Systems Integration 800.366.3891, extension 73000 (USA and Canada) 952.917.3000	<ul style="list-style-type: none"> • Complete Solutions (from concept to installation) • Network Design and Integration Testing • System Turn-Up and Testing • Network Monitoring (upstream or downstream) • Power Monitoring and Remote Surveillance • Service/Maintenance Agreements • Systems Operation
BIA Technical Assistance Center 800.638.0031 714.730.3222 Fax: 714.730.2400 Email: wsd_support@adc.com	<ul style="list-style-type: none"> • Technical Information • System/Network Configuration • Product Specification and Application • Training (product-specific) • Installation and Operation Assistance • Troubleshooting and Repair/Field Assistance
Online Technical Support	<ul style="list-style-type: none"> • www.adc.com/Knowledge_Base/index.jsp
Online Technical Publications	<ul style="list-style-type: none"> • www.adc.com/library1/
Product Return Department 800.366.3891 ext. 73748 or 952.917.3748 Fax: 952.917.3237 Email: repair&return@adc.com	<ul style="list-style-type: none"> • ADC Return Material Authorization (RMA) number and instructions must be obtained before returning products.
<i>All 800 lines are toll-free in the USA and Canada.</i>	

APPENDIX E - ABBREVIATIONS

A

ACO: Alarm CutOff
ACON: Auto Conversion of DS1 frame
AIS: Alarm Indication Signal
ALM: Alarm
AM: Alternate Mark Inversion
AWG: American Wire Gauge

B

B8ZS: Bipolar with 8-Zero Substitution
BER: Bit Error Rate
BPV: Bipolar Violation
BPVT: Bipolar Violation Transparency
BRG: Bridge

C

CLEI: Common Language Equipment Identifier
CLOC: Customer Local Loopback
CO: Central Office
CPE: Customer Premises Equipment
CRC: Cyclical Redundancy Check
CREM: Customer Remote Loopback
CRG: Customer Regenerator Loopback
CSA: Carrier Service Area
CV: Code Violation

D

DBER: DS1 Bit Error Rate
DDS: Digital Data Service
DL: Datalink
DLC: Digital Loop Carrier
DS0: Digital Signal, level 0
DS1: Digital Signal, level 1
DSX-1: DS1 Cross-connect Frame

E

ECI: Equipment Catalog Item
ES: Errored Seconds
ESF: Extended SuperFrame
EXZ: The occurrence of 8 consecutive zeroes for B8ZS or 16 for AMI.

F

FCON: Framed Conversion of DS1 frame
FDL: Facility Datalink
FE: Far End
FT1: Fractional T1

G

GNLB: Generic Loopback

H

H2TU-C:
 HiGain Solitaire Line Unit
H2TU-R:
 HiGain Solitaire Remote Unit
HBER: HDSL2 Block Error Rate
HCDS: High Capacity Digital Service
HCS: HiGain Card Shelf
HDSL2: High-bit-rate Digital Subscriber Line 2
HG: HiGain

I

ID: Identifier
ILR: Intelligent Line Repeater
IN: Transmit
IOR: Intelligent Office Repeater
IR: Intelligent Repeater

L

LA: Loop Attenuation
LED: Light Emitting Diode
LOF: Loss of Frame
LOS: Loss of Signal
LOSW: Loss of Sync Word
LPF: Line Power Feed

M

M: HDSL2 Margin
MSEC: Monitored Seconds

N

NE: Near End
NI: Network Interface
NID: Network Interface Device
NIU: Network Interface Unit
NLOC: Network Local Loopback
NMA: Network Management and Administration
NPRM: Network Performance Report Messaging
NREM: Network Remote Loopback
NRG: Network Regenerator Loopback
NVRAM:
 Non-Volatile Random Access Memory

O

OOF: Out of Frame

OPTIS: Overlapped Pulse Amplitude Modulation Transmission with Interlocking Spectra

ORB: Office Repeater Bay

OUT: Receive

P

PDVS: Pulse Density Violation Seconds

PL: Payload Loopback Command

PRM-FE: Performance Report Messaging - Far End

PRM-NE: Performance Report Messaging - Near End

PWRF: Power Feed

R

RA: Remote Alarm Indication

RAIS: Remote Alarm Indication Signal

RLOS: Remote Loss of Signal

S

SES: Severely Errored Seconds

SF: SuperFrame

SMJK: SmartJack

SPLB: Special Loopback

SPRM: Supplemental Performance Report Messaging

T

TLOS: Transmit Loss of Signal

U

UAS: Unavailable Seconds

CERTIFICATION AND WARRANTY

FCC CLASS A COMPLIANCE

This equipment has been tested and found to comply with the limits for a Class A digital device, pursuant to Part 15 of the FCC Rules. These limits are designed to provide reasonable protection against harmful interference when the equipment is operated in a commercial environment. This equipment generates, uses, and can radiate radio frequency energy and, if not installed and used in accordance with the instruction manual, may cause harmful interference to radio communications. Operation of this equipment in a residential area is likely to cause harmful interference in which case the user will be required to correct the interference at his own expense.

LIMITED WARRANTY

ADC DSL Systems, Incorporated (“ADC”) warrants that, for a period of sixty (60) months from the date of shipment, the hardware portion of its products will be free of material defects and faulty workmanship under normal use. ADC's obligation, under this warranty, is limited to replacing or repairing, at ADC's option, any such hardware product which is returned during the 12-month warranty period per ADC's instructions and which product is confirmed by ADC not to comply with the foregoing warranty.

ADC warrants that, for a period of 90 days from the date of purchase, the software furnished with its products will operate substantially in accordance with the ADC published specifications and documentation for such software. ADC's entire liability for software that does not comply with the foregoing warranty and is reported to ADC during the 90-day warranty period is, at ADC's option, either (a) return of the price paid or (b) repair or replace of the software. ADC also warrants that, for a period of thirty (30) days from the date of purchase, the media on which software is stored will be free from material defects under normal use. ADC will replace defective media at no charge if it is returned to ADC during the 30-day warranty period along with proof of the date of shipment.

The transportation charges for shipment of returned products to ADC will be prepaid by the Buyer. ADC will pay transportation charges for shipment of replacement products to Buyer, unless no trouble is found (NTF), in which case the Buyer will pay transportation charges.

ADC may use reconditioned parts for such repair or replacement. This warranty *does not* apply to any product which has been repaired, worked upon, or altered by persons not authorized by ADC or in ADC's sole judgment has subjected to misuse, accident, fire or other casualty, or operation beyond its design range.

Repaired products have a 90-day warranty, or until the end of the original warranty period—whichever period is greater.

ADC DISCLAIMS ALL OTHER WARRANTIES, EITHER EXPRESS OR IMPLIED, INCLUDING BUT NOT LIMITED TO IMPLIED WARRANTIES OF MERCHANTABILITY AND FITNESS FOR A PARTICULAR PURPOSE, WITH RESPECT TO ITS PRODUCTS AND ANY ACCOMPANYING WRITTEN MATERIALS. FURTHER, ADC DOES NOT WARRANT THAT SOFTWARE WILL BE FREE FROM BUGS OR THAT ITS USE WILL BE UNINTERRUPTED OR REGARDING THE USE, OR THE RESULTS OF THE USE, OF THE SOFTWARE IN TERMS OF CORRECTNESS, ACCURACY, RELIABILITY OR OTHERWISE.

MODIFICATIONS

Any changes or modifications made to this device that are not expressly approved by ADC DSL Systems, Inc. voids the user's warranty.

All wiring external to the products should follow the provisions of the current edition of the National Electrical Code.

STANDARDS COMPLIANCE

The H2TU-C-231 List 1E has been tested and verified to comply with the applicable sections of the following standards:

- GR 63-CORE - Network Equipment-Building System (NEBS) Requirements
- GR 1089-CORE - Electromagnetic Compatibility and Electrical Safety
- Binational standard, UL-1950/CSA-C22.2 No. 950-95: Safety of Information Technology Equipment

For technical assistance, refer to [“Appendix D - Product Support” on page 65](#).

ADC DSL Systems, Inc.

14402 Franklin Avenue
Tustin, CA 92780-7013

Tel: 714.832.9922

Fax: 714.832.9924

Technical Assistance

Tel: 800.638.0031

Tel: 714.730.3222

Fax: 714.730.2400



DOCUMENT: 152-231-115-03



1216269

