

QUICK INSTALLATION

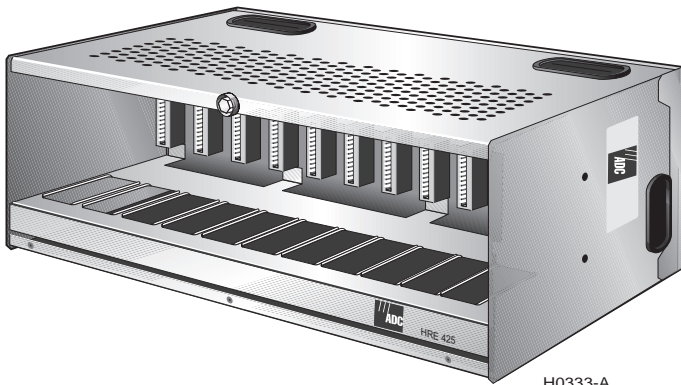

HRE-425 LIST 1 LINE UNIT



THE HRE-425 LIST 1

The HiGain® HRE-425 List 1 is a remote enclosure designed to house HiGain line units, doubler units, and remote units.

FEATURES

-
- 12 slots (slot 12 may be used to provide a -48 Vdc local power supply)
 - Backplane provides wire-wrap or connector interface options
 - Separate fuses for each slot
 - Tamperproof screw for security
 - Optional RJ48C or RJ48X modular jack assemblies for DS1 customer interface
 - Supports T1 (DS1) and E1 (G.703) applications
 - Desktop location or wall or rack mounting
-

SPECIFICATIONS

Mounting	Twelve 400 or 200 mechanics units
Telco facility	25-pair, type 57, male connector (P3), wire wrap 25-pair, type 57, male connector (P4), wire wrap
CPE	DS1 / E1 RCV (output toward the CPE): 25-pair, type 57, male connector (P1) or wire wrap DS1 / E1 XMT (input from the CPE): 25-pair, type 57, male connector (P2) or wire wrap Optional 12-port, harmonic, connector cable assemblies: RJ-48 C (150-2201-01) or RJ-48X (150-2201-02)
In-shelf power supply options	120 Vac to 48 Vdc @ 2 A Customer supplied: Westel 6060-03, Wexcom 8548-13, or Troncom MPS-2500 ADC: HPS-448
Fusing	0.5 A protection per slot
Height	8.75 in. (23 cm)
Width	17.4 in. (45 cm)
Depth	11.5 in. (30 cm)
Weight	22 lb. (9.9 kg)

INSTALLATION KIT

-
- 4 rack mounting screws
 - 4 bracket screws with locking nuts
 - 4 plastic cable tie wraps
 - 0.5 A fuse
 - 2A fuse for slot 12
 - Two 19-inch or 23-inch rack mounting brackets
 - Circuit assignment card
 - Plastic holder for circuit assignment card
-



Plugs compatible with the HRE-425 List 1 include: HLU-431, HLU-432, HDU-404, HDU-451, EDU-451, HRU-402, H2TU-R-402, and ERU-412. Documentation for these products can be downloaded from the ADC website at www.adc.com.

1 INSTALLATION

The HRE-425 List 1 can be placed on a desk or mounted on a wall rack or equipment rack.

Wall Mounting

- 1 Loosen the four rear-panel locking bolts and remove the backplate (Figure 1).

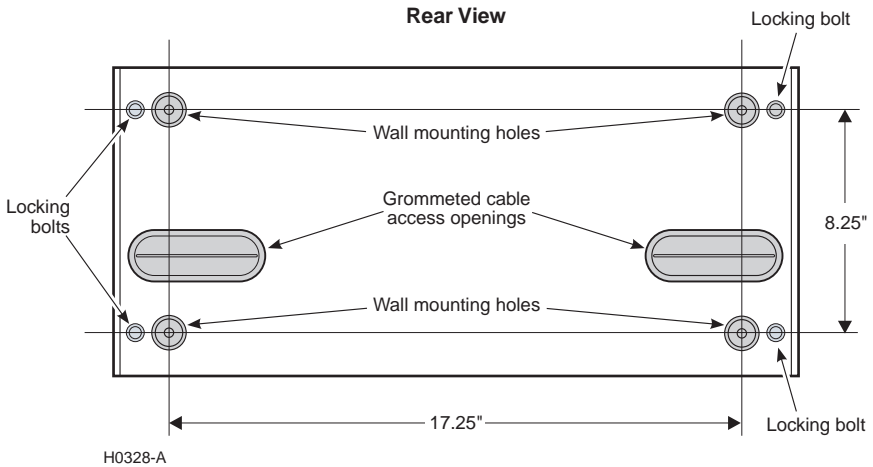

Figure 1. HRE-425 List 1 Backplate

- 2 Using the backplate as a template, mark the wall locations for drilling the wall mounting holes.
- 3 Drill pilot holes and attach the backplate to the backboard with the four #10 x $\frac{3}{4}$ -inch PHS wood screws and washers supplied.
- 4 Use the four locking bolts loosened in Step 1 as hinge mounting bolts to reattach the backplate to the chassis side panels. For access to the backplane and other areas, the chassis can be rotated up or down by removing the two upper or two lower mounting bolts and slightly loosening the two remaining bolts.

Rack Mounting

The HRE-425 can be mounted into a 19- or 23-inch relay rack with one of the two rack mounting brackets that are provided in the installation kit.

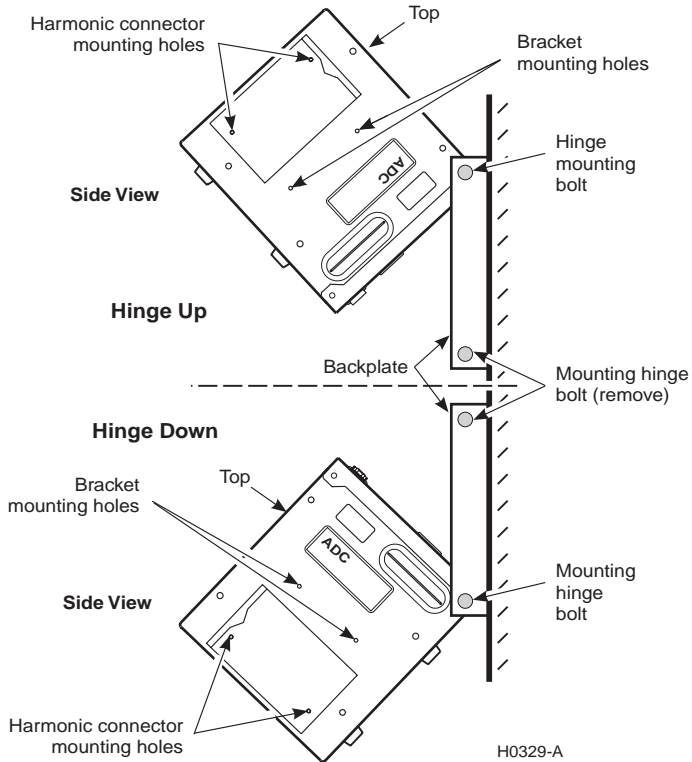

Figure 2. *Wall Mounting and Hinging View*

- 1 Orient the mounting brackets to the side panels consistent with the rack size (19- or 23-inch).
- 2 Attach the rack mounting brackets to the bracket mounting holes (Figure 2) on each side panel with the four bracket attaching screws and locking nuts.
- 3 Attach the HRE-425 to the rack with the four mounting screws included.

2

BACKPLANE CONNECTIONS

The HRE-425 List 1 backplane (Figure 3) can be connected in one of the following ways:

- wire-wrap connections to each of the 12 card-edge connectors (J1 through J12)
- terminal block connections to TB1
- 25-pair, multiple connectors (P1, P2, P3, and P4)

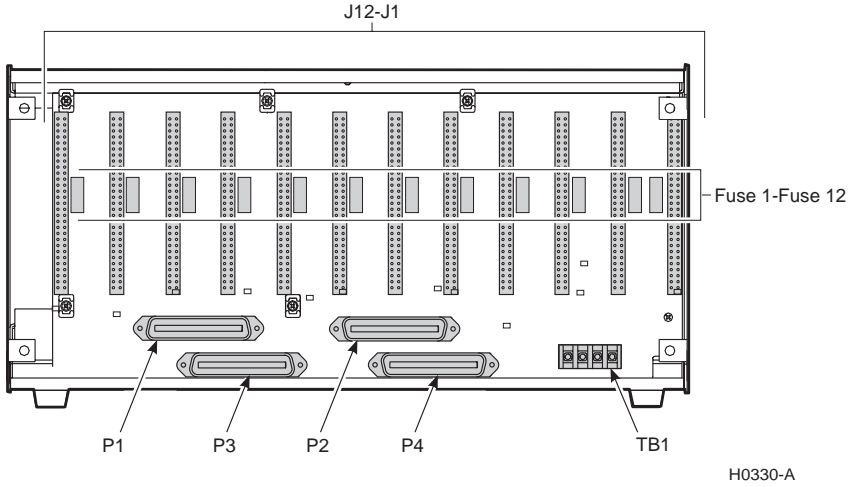

Figure 3. HRE-425 List 1 Backplane

3

POWER FUSES AND GROUNDING

Each of the 12 slots are equipped with a 0.5A fuse between the -48 Vdc shelf supply and pin 35 as shown in Figure 4. This accommodates the maximum power consumption requirements when using the HRE-425 to house doubler or remote units.

All the fuse alarm contacts are transmitted together on one bus and connected to the Fuse Alarm, pin 3 of TB1. If a fuse opens, the normally floating Fuse Alarm in pin 3 drives to -48 Vdc.

When slot 12 is used for an internal -48 Vdc shelf supply, fuse F12 becomes the shelf fuse and must be replaced by the 2A fuse included in the installation kit. If F12 opens in this application, the Fuse Alarm is left open and will not be driven to -48 Vdc (as would be the case if an external power supply were lost).

The internal supply in slot 12 is limited by 2A fuse F12 in order to be compatible with the maximum current rating of typical, 400 mechanics shelf supplies. This 2A capacity is sufficient when HRU remote units are used in the other 11 slots but not when HLU-431 line units are used. An external power supply rated at a minimum of 5A is required to provide adequate power to a shelf full of HLU-431 line units operating under maximum load. See the HLU-431 technical practice for additional information.

Properly ground the HRE case to avoid shock hazard to craft personnel, bit errors due to noise and crosstalk, and damage to HRU circuits. ADC recommends that pin 4 of TB1, frame ground, be connected to earth ground.



The HRE-425 List 1 provides access to frame ground on pins 1 and 27 of each slot connector.

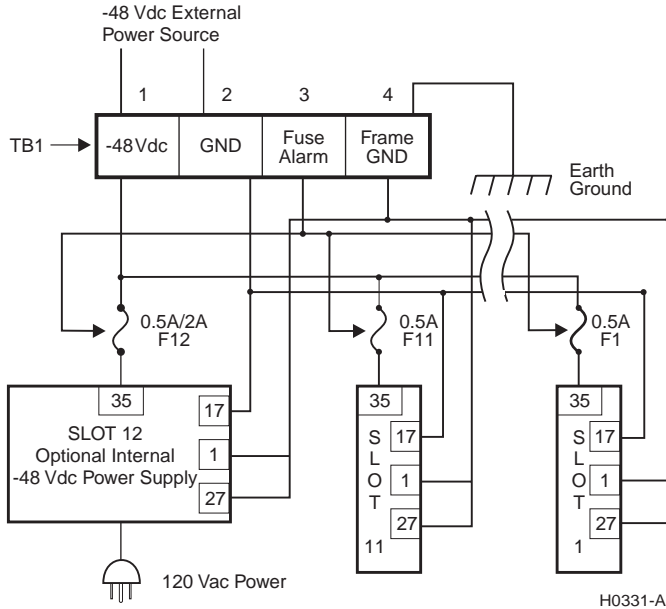

Figure 4. HRE-425 List 1 Shelf Fusing, Backplane Wiring, and Bus Connections

4 FIELD SIDE HDSL CONNECTIONS

Connect the HDSL field side ports to the appropriate wire wrap pins of each connector. To determine slot and pin assignments, refer to the documentation for the product being installed.

You can also use these connections to access the two HDSL CO side Loop 1 IN and Loop 2 IN pairs for doubler applications.

The two HDSL facilities access cables that terminate on P3 and P4 provide the necessary XMT and RCV isolation required if the HRE-425 is used to provide access to standard T1 facilities, such as when T1 plugs like SmartJack network interface devices (NIDs) are used. Refer to the block diagram on the rear panel for HDSL slot and pin assignments.

5

CPE DS1 (G.703) CONNECTIONS

Do one of the following:

- Connect the XMT and RCV interfaces to the appropriate wire wrap pins of each connector. To determine slot and pin assignments, refer to the documentation for the product being installed.
- Connect the XMT and RCV interfaces to P1 and P2 connectors.
- Purchase optional 12-port RJ48 harmonic cable assemblies from ADC for the CPE interface : RJ48C (Part Number 150-2201-01) or RJ48X (Part Number 150-2201-02). You can attach these cable assemblies to the top, bottom, or either of the two side panels through the wall mounting holes located on each panel. **Figure 1** shows the locations of these mounting holes on the side panel.

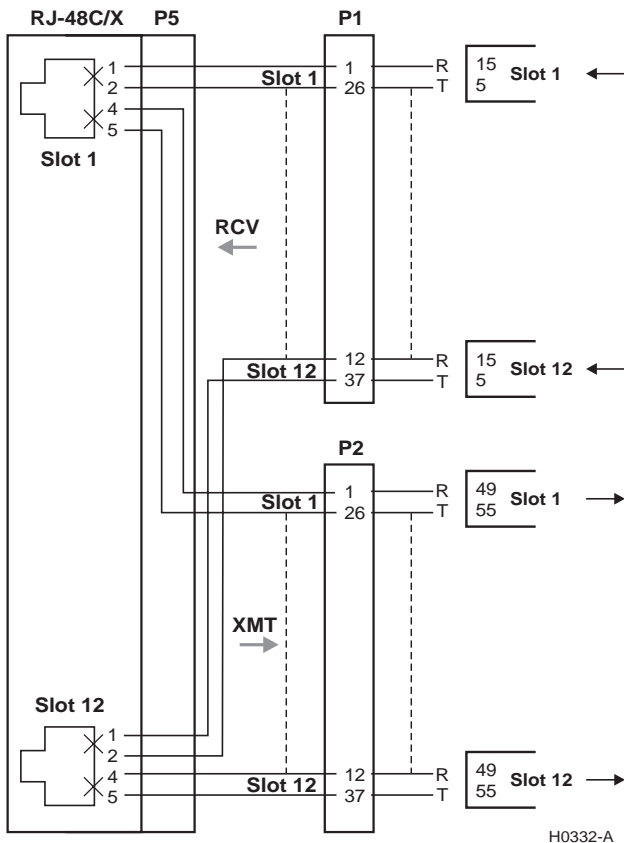

Figure 5. Twelve-Port, Harmonic Cable DS1 Interface Assemblies

6

TURN-UP

Before handling plug-in modules, attach a wrist strap to the antistatic jack on the front of the enclosure (lower left-hand side).

- 1 Open the front panel of the enclosure by loosening the Hex nut at the top, then lower the panel.
- 2 Insert the card in its assigned slot. Refer to the card's user manual for complete information.

FCC Class A Compliance

The HRE-425 List 1 does not have any clocking source, and is deemed to be a passive device per FCC guidelines. When used in conjunction with any clocking devices, this combined system may radiate radio frequency energy that can cause harmful interference to radio communications. Operation of such a system in a residential area is likely to cause harmful interference, in which case the user will be required to correct the interference at his own expense.

Limited Warranty

Product warranty is determined by your service agreement. Contact your sales representative or Customer Service for details.

Modifications

Any changes or modifications made to this device that are not expressly approved by ADC DSL Systems, Inc. voids the user's warranty.

All wiring external to the products should follow the provisions of the current edition of the National Electrical Code.

Standards Compliance

This equipment has been tested and verified to comply with the applicable sections of the following safety standards:

- GR 63-CORE - Network Equipment-Building System (NEBS) Requirements
- Binational standard UL-1459/1950: Safety of Information Technology Equipment

Trademark Information

ADC is a registered trademark of ADC Telecommunications, Inc. HiGain is a registered trademark of ADC DSL Systems, Inc. Other product names mentioned in this installation guide are used for identification purposes only and may be trademarks or registered trademarks of their respective companies.

Copyright Information

© 2000 ADC DSL Systems, Inc. All rights reserved. Information contained in this document is company private to ADC DSL Systems, Inc., and shall not be modified, used, copied, reproduced or disclosed in whole or in part without the written consent of ADC.

ADC DSL Systems, Inc.

14402 Franklin Avenue
Tustin, CA 92780-7013
Tel: 714.832.9922
Fax: 714.832.9924

Technical Assistance

Tel: 800.638.0031
Tel: 714.730.3222
Fax: 714.730.2400

Product Catalog: 150-1114-01
CLEI: T1MFF504
Document: 350-425-100-02



1247041
May 26, 2000