

---

# HiGAIN LINE UNIT

Model	List Number	Part Number	CLEI Code
HLU-231	8A	150-1111-81	T1L2PY0AA

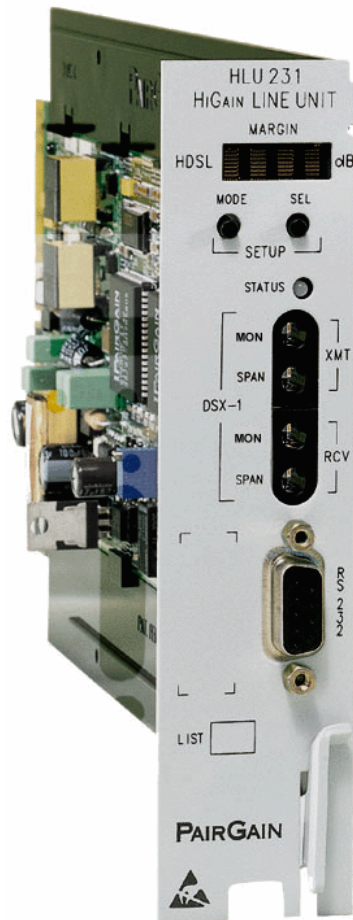

**PAIRGAIN TECHNOLOGIES, INC.**  
**ENGINEERING SERVICES TECHNICAL PRACTICE**  
**150-231-181-01**

---

**PAIRGAIN**

---

**Revision History of This Practice**

<b>Revision</b>	<b>Release Date</b>	<b>Revisions Made</b>
01	September 7, 1999	Initial release

**© Copyright 1999 PairGain Technologies, Inc.**

*PairGain and HiGain are registered trademarks of PairGain Technologies, Inc. All other product names mentioned in this practice are used for identification purposes only and may be trademarks or registered trademarks of their respective companies.*

*Information contained in this document is company private to PairGain Technologies, Inc., and shall not be modified, used, copied, reproduced or disclosed in whole or in part without the written consent of PairGain.*

*Information furnished by PairGain Technologies is believed to be accurate and reliable. However, no responsibility is assumed by PairGain Technologies for its use; nor for any infringement of patents or other rights of third parties which may result from its use. No license is granted by implication or otherwise under any patent or patent rights of PairGain Technologies. PairGain Technologies reserves the right to change specifications at any time without notice.*

## USING THIS TECHNICAL PRACTICE

The following conventions are used in this manual:

- Monospace type indicates screen text, including text you type at a screen prompt.
- Keys you press are indicated by small icons such as **ENTER**. Key combinations to be pressed simultaneously are indicated with a plus sign as follows: **CTRL** + **ESC**.
- Three types of messages, identified by icons, appear in text.



**Notes contain information about special circumstances.**



**Cautions indicate the possibility of equipment damage or personal injury.**



**The Electrostatic Discharge (ESD) Susceptibility symbol indicates that a device or assembly is susceptible to damage from electrostatic discharge.**

For a list of abbreviations used in this document, refer to “[Appendix E - Glossary](#)” on page 66.

## DOCUMENTATION

If you have comments on this PairGain document, send an email to [technical\\_publications@pairgain.com](mailto:technical_publications@pairgain.com). Type the product name and the section number of the document in the subject area of the email message.

## INSPECTING THE SHIPMENT

Upon receipt of the equipment:

- Unpack each container and inspect the contents for signs of damage. If the equipment has been damaged in transit, immediately report the extent of damage to the transportation company and to PairGain. Order replacement equipment, if necessary.
- Check the packing list to ensure complete and accurate shipment of each listed item. If the shipment is short or irregular, contact PairGain as described in the Warranty located inside the back cover. If you must store the equipment for a prolonged period, store the equipment in its original container.



# TABLE OF CONTENTS

<b>Overview</b>	<b>1</b>
Features	1
Product Enhancements	1
Standard Features	1
Compatibility	2
Applications	2
HiGain Doubler Applications	2
Personal Communications System Applications	3
<b>Front Panel</b>	<b>4</b>
<b>Installation</b>	<b>8</b>
Verification	9
Verification without a Downstream Device	9
Verification with a Downstream Device	9
Provisioning Requirements	10
<b>Provisioning</b>	<b>11</b>
Using the MODE and SEL Buttons	11
Setting Options through MODE and SEL	11
Resetting to Factory Default Values	12
Displaying System Parameter Settings	12
Disabling an Alarm	12
Loopback Modes	12
Using a Maintenance Terminal	13
Connecting to a Maintenance Terminal	13
Accessing the Maintenance Terminal Screens	13
Navigation Keys	13
Maintenance Terminal Main Menu	14
Selecting a Maintenance Terminal Function	15
System Spans	15
Using the Maintenance Terminal Screens	15
View Span Status Screen	15
Span Status Screen without Doublers	16
Span Status Screen for Doubler Applications	16
Set Clock Screen	19
Set Time	19
Set Date	19
Update the HRU Time and Date	19

System Settings Screen .....	20
Equalization Option .....	23
BPVT Option .....	23
BER Option .....	24
DS0 Blocking Option .....	24
DS1 Line Code Option .....	24
Margin Alarm Threshold Option .....	25
HAIS Option .....	25
HDSL Line Voltage Options .....	25
Loopback Mode Screen .....	26
Loopback Menu without Doubler .....	27
Loopback Menu for Doubler Applications .....	27
Initiating a Loopback .....	28
Disabling a Loopback .....	28
View Performance Data Screen .....	29
Performance Data Screen without Doubler .....	30
Performance Data Screen for Doubler Applications .....	30
View Performance History Screen .....	31
Performance History Screen without Doubler .....	31
Performance History Screen for Doubler Applications .....	32
View Alarm History Screen .....	33
Alarm History Screen without Doubler .....	34
Alarm History Screen for Doubler Applications .....	34
View System Inventory Screen .....	35
System Inventory Screen without Doubler .....	36
System Inventory Screen for Doubler Applications .....	36
View Troubleshooting Screen .....	37
<b>Troubleshooting</b> .....	<b>41</b>
System Alarms .....	41
Alarm Option for DLC Feed .....	42
Retiring System Alarms .....	42
Self Test .....	42
Loopback Operation .....	43
Generic Loopback Commands .....	43
Special Loopback Commands .....	45
Initiating a Manual Loopback Session .....	46
Setting the Loopback Time-out Option .....	46

Initiating a Manual Loopback Session .....	46
Loopback Test Procedures .....	47
General Troubleshooting Tips .....	47
GNLB Test Procedures .....	47
A1LB, A2LB, and A5LB Test Procedures .....	49
A3LB and A4LB Test Procedures .....	52
<b>Appendix A - Specifications</b> .....	<b>53</b>
HDSL Insertion Loss Guidelines .....	54
Power Consumption .....	54
Power Consumption without Doublers .....	54
Power Consumption with Doublers .....	55
Maximum Power Dissipation .....	57
Maximum Current Drain .....	57
HLU-231 List 8A Card Connector .....	58
Network Management Control Bus .....	58
Fuse Alarm .....	58
System Alarm Relay Output .....	59
Craft Port .....	59
<b>Appendix B - Functional Operation</b> .....	<b>60</b>
Timing .....	60
Ground Fault Detect .....	61
<b>Appendix C - Compatibility</b> .....	<b>62</b>
T1 Repeater Shelves and Related Equipment .....	62
HiGain Doubler Circuit Deployment .....	62
<b>Appendix D - Product Support</b> .....	<b>64</b>
Technical Support .....	64
World Wide Web .....	64
Returns .....	64
<b>Appendix E - Glossary</b> .....	<b>66</b>
<b>Certification and Warranty</b> .....	<b>Inside Back Cover</b>

## LIST OF FIGURES

1. HLU-231 List 8A Front Panel .....	4
2. Installing the HLU-231 List 8A into a Shelf .....	8
3. Maintenance Terminal Main Menu .....	14
4. System Spans .....	15
5. Span Status Screen: No Doubler.....	16
6. Span Status Screen: Four Doublers (Span 5).....	16
7. Set Clock Screen.....	19
8. System Settings Screen .....	20
9. Loopback Menu: No Doubler .....	27
10. Loopback Menu: Four Doublers.....	27
11. NLOC Loopback Mode Reported in the Maintenance Terminal Main Menu.....	28
12. Performance Data Screen: No Doubler.....	30
13. Performance Data Screen: Four Doublers (Span 5).....	30
14. 31-Day Performance History Screen: No Doubler .....	31
15. 31-Day Performance History Screen: Four Doublers (Span 5) .....	32
16. Alarm History Screen: No Doubler .....	34
17. Alarm History Screen: Four Doublers (Span 5) .....	34
18. System Inventory Screen: No Doubler .....	36
19. System Inventory Screen: Four Doublers .....	36
20. Troubleshooting Screen for a Doubler Application.....	37
21. Troubleshooting Screen Describing Circuit Problem .....	37
22. Troubleshooting with Help .....	38
23. Troubleshooting with Margin Values .....	39
24. Troubleshooting with Insertion Loss Values .....	39
25. Troubleshooting with 24-Hour Errored Seconds (ES) .....	40
26. Troubleshooting with 24-Hour Unavailable Seconds (UAS) .....	40
27. Loopback Summary .....	43
28. Loopback Configurations .....	48
29. HLU-231 List 8A Card-edge Connector .....	58
30. RS-232 Craft Port Pinouts .....	59
31. HLU-231 List 8A Block Diagram .....	60



## LIST OF TABLES

1. Front-panel Description.....	5
2. Front-panel Display Messages .....	6
3. Navigational Keys on the Maintenance Terminal .....	13
4. Maintenance Terminal Screens .....	14
5. Span Status Fields and Descriptions.....	17
6. HDSL System Alarms .....	18
7. Loopback Messages.....	18
8. HLU-231 List 8A System Settings.....	21
9. Loopback Field Messages and Descriptions .....	26
10. Errored and Unavailable Seconds Definitions .....	29
11. Alarm History Fields and Descriptions .....	33
12. HDSL System Alarms .....	41
13. Summary of HiGain Loopback Codes .....	44
14. Addressable Repeater Loopback Commands (A1LB, A2LB, A5LB) .....	49
15. Addressable Repeater Loopback Commands (A3LB and A4LB) .....	52
16. HDSL Loss Over Cables .....	54
17. Power Parameters—No Doubler .....	54
18. Power Parameters—Single Doubler (HDU-451 List 1 or 2).....	55
19. Power Parameters—Single Doubler (HDU-439 or HDU-437 Lists 1 and 1B).....	55
20. Power Parameters—Single Doubler (HDU-404 List 2, HDU-407 List 2, and HDU-409 List 2).....	55
21. Power Parameters—Two Doublers (HDU-451 List 3, 4, 3B or 4B).....	56
22. Power Parameters—Two Doublers (HDU-439 or HDU-437 Lists 1 and 1B).....	56
23. Power Parameters—Two Doublers (HDU-404 List 2, HDU-407 List 2, and HDU-409 List 2).....	56
24. Power Parameters—Three and Four Doublers (HDU-404 List 2, HDU-407 List 2, and HDU-409 List 2).....	56
25. HiGain Doubler Deployment Matrix.....	63



# OVERVIEW

The PairGain® HiGain® Line Unit HLU-231 List 8A is the Central Office (CO) side of a repeaterless T1 transmission system. When used in conjunction with a HiGain Remote Unit (HRU), the system provides 1.544 Mbps transmission on two unconditioned copper pairs over the full Carrier Service Area (CSA) range. The CSA includes loops up to 12,000 feet of 24 AWG or 9,000 feet of 26 AWG wire, including bridged taps. This line unit can be used with HiGain Doubler Units (HDUs) to extend reach.

## FEATURES

### Product Enhancements

- Five-span range with four doublers (60 kft, 24 AWG)
- Four line-powered spans (three doublers and one remote)
- Reduced power consumption
- Ultra-low wander (Stratum 1 compliant)
- Low line-power option (-140 Vdc) for circuits with a single doubler
- Selectable Power Feed (PWRF) modes: Auto, High and Low
- Grounded loop detection on High-bit-rate Digital Subscriber Line (HDSL)
- Bipolar Violation Transparency (BPVT) options
- Bit Error Rate (BER) alarm options
- HRU loopback screen
- Inventory and troubleshooting screens
- Loss of Signal/Alarm Indicator Signal (LOS/AIS) payload alarm option
- Remote Loss of Signal (RLOS) disable alarm option
- Supports HRU-411 in PCS applications
- Default setting screen option
- Payload (PL) or HiGain (HG) loopback source identification

### Standard Features

- Selectable DS1 pre-equalizer
- Front-panel features:
  - Four-character status display
  - DS1 splitting and bridge access
  - Status LED
  - RS-232 craft port for connection to a maintenance terminal
- Compatible with SXSS shelves, and equivalent
- Selectable loopback activation codes
- Network Management and Administration (NMA) interface

- Lightning and power cross protection on HDSL interfaces
- Full duplex 2B1Q HDSL transmission on two pairs at 784 kbps
- Margin threshold alarm

## COMPATIBILITY

The HLU-231 List 8A is designed to be mounted in 220 mechanics shelves. For a list of compatible shelves, see [“Appendix C - Compatibility”](#) on page 62.

All generations of HiGain HLU and HRU modules are compatible with each other. To take advantage of the enhanced features of newer HiGain doublers, refer to [“HiGain Doubler Circuit Deployment”](#) on page 62.

## APPLICATIONS

HiGain systems provide a cost-effective, easy-to-deploy method for delivering T1 High Capacity Digital Service (HCDS) over metallic pairs.

- The service is deployed over two unconditioned, non-loaded copper pairs, yet it demonstrates a quality that is competitive with fiber optics.
- Conventional, in-line, T1 repeaters are not required.
- Cable pair conditioning, pair separation and bridged tap removal are not required.

In general, HiGain systems:

- Operate with any number of other T1, POTS, Digital Data Service (DDS) or other HiGain systems sharing the same cable binder group
- Can be used with customers requiring DS1 service on a temporary or permanent basis
- Provide a means of quickly deploying service in advance of fiber-optic transmission systems.

With a HiGain system, service can be provided within hours. Fiber-optic systems can be installed incrementally and cut-over from the installed HiGain system when convenient to do so.

## HiGain Doubler Applications

For applications without doublers, the HLU-231 is directly connected to the HRU by the two HDSL cable pairs. The HLU-231 List 8A is compatible with all HiGain HRUs.

For doubler applications, one to four doublers may be used in the HDSL loops between the HLU and HRU.

- If the HRU is line-powered, the HLU-231 List 8A can power three doublers and the remote unit (HRU-402 or HRU-411) for a total of four spans.
- If the HRU is locally powered, the HLU can power up to four doublers for a total of five spans.



**These extended ranges are only available when using the HDU-409, HDU-404 or HDU-407 micro-doublers with the HRU-411 or HRU-402. Older doublers (HDU-451, HDU-439 and HDU-437) cannot be used in circuits with more than two doublers in any line or local power system. For compatibility guidelines on mixing newer doublers with older HRU and HLU models, refer to [“HiGain Doubler Circuit Deployment”](#) on page 62.**

**For additional information about associated HiGain equipment, refer to the respective HiGain technical practice (see [“Appendix D - Product Support”](#) on page 64).**

## Personal Communications System Applications

The HLU-231 List 8A is required for Personal Communications System (PCS) applications that use the HRU-411. The HRU-411 has an onboard 130 Vdc, 8.5 W power supply that can power the 200 mW PCS remote radio ports. The line unit recognizes the HRU-411 (if CPE POWER switch is set to ON) and performs the following two functions required by the HRU-411 to bring up the NEC radio port:

- Increases the HDSL line voltage to its high  $\pm 112$  Vdc level with the PWRF option set to AUTO
- Enables HRU-411 to turn on its 130 Vdc radio port supply

# FRONT PANEL

The HLU-231 List 8A front panel is shown in [Figure 1](#). The front-panel components are described in [Table 1](#) on [page 5](#). For pinout diagrams of the HLU card-edge connector and the craft port, refer to “[Appendix A - Specifications](#)” on [page 53](#).

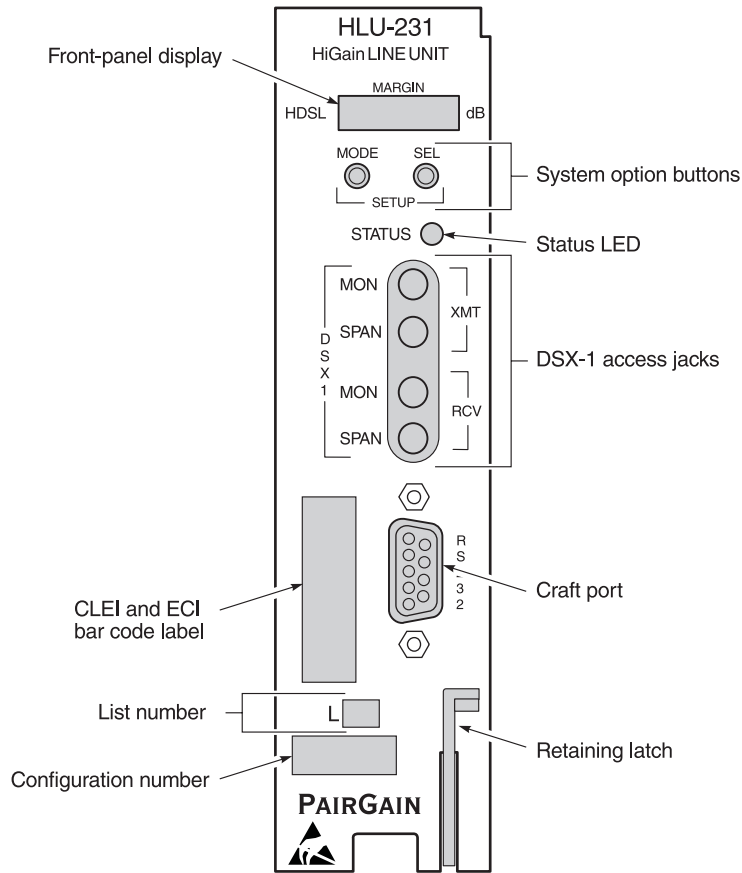

*Figure 1. HLU-231 List 8A Front Panel*

**Table 1. Front-panel Description**

<b>Front-panel Feature</b>	<b>Function</b>
Front-panel display	Displays four-character status, provisioning, and alarm system messages. The front-panel display illuminates when power is initially applied. To conserve power the display only remains on for 4 minutes. Using the MODE or SEL buttons reactivates the display and restarts the 4-minute timer. Refer to <a href="#">Table 2 on page 6</a> for a listing of the four-character messages.
System option buttons (MODE and SEL)	Permits the user options to be monitored and modified without the need of a maintenance terminal. Used to initiate all HiGain loopbacks and to display DSX-1 line parameters and line unit identity.
Status LED	The status LED can report the following conditions:
Green	Normal operation
Red	Fuse Alarm
Flashing red	System alarm or HDSL acquisition
Yellow	Self Test is in process or an HLU-231 List 8A Customer Remote Loopback (CREM) or a Network Local Loopback (NLOC) is in effect.
Flashing yellow	HLU-231 List 8A is Armed to respond to Intelligent Repeater Loop (ILR) codes.
DSX-1 access jacks	
SPAN	Provides splitting jack access to (XMT) and from (RCV), the HDSL span at the DSX-1 interface. Breaks the XMT and RCV paths to permit test signal insertion and retrieval.
MON	Provides non-intrusive monitoring jack access to (XMT) and from (RCV) the HDSL span at the DSX-1 interface. Allows the two T1 payloads to be monitored.
Craft (RS-232) port	Provides bidirectional communication between the unit and an external terminal to allow configuration and performance monitoring through the Maintenance Terminal screens.
CLEI and ECI bar code label	Provides the human-readable Common Language Equipment Identifier (CLEI) code number and the Equipment Catalog Item (ECI) bar code number.
List number	Identifies the version of the HLU-231.
Retaining latch	Retains the card in the shelf when pulled up and extracts the card from the shelf when pulled down.
Configuration number	Contains either a five or six-digit warranty configuration number or a stand-alone two or three-digit configuration number as follows: Digit 1 - Last digit of shipment year Digits 2 and 3 - Shipment month Digits 4, 5, and 6 - Configuration number The configuration number can also be found on a small bar label that contains the Julian date code and part number. This gummed label may be affixed to the PC board or to the front panel.

Table 2 lists the front-panel display messages. The four-character displays reports the code of a pertinent alarm, loopback or diagnostic message, in some cases followed by a second four-character message that modifies the first message with a value or current configuration setting.

**Table 2.** *Front-panel Display Messages*

Message	Full Name	Description
<b>ALARM MESSAGES</b>		
ACO	Alarm CutOff	A system alarm has occurred, and has been retired to an ACO condition by pressing the SEL button on the HLU front panel.
ALRM	Alarm Condition	A system alarm condition is in effect.
BER	Bit Error Rate	A system BER alarm is in effect.
LLOS	Local Loss of Signal	Indicates that no signal is detected at the T1 input to the HLU. Causes a system alarm.
LOSW	Loss of Sync Word	Indicates that one of the HDSL loops has lost sync. Causes a system alarm.
MAL1 or MAL2	Margin Alarm Loop 1 or Loop 2	The margin on HDSL Loop 1 or Loop 2 has dropped below the threshold (1 to 15 dB) as set by the operator.
RLOS	Remote Loss of Signal	Indicates that no signal is detected at the DS1 input to the HRU. Causes a system alarm.
<b>LOOPBACK MESSAGES</b>		
CDU $n$ ?	Customer Doubler $n$ Loopback	Query to initiate loopback at doubler $n$ to CI, where $n$ is the number of the doubler.
CLOC	Customer Local Loopback	Signal from customer is looped back to the customer at the HRU.
CREM	Customer Remote Loopback	Signal from customer is looped back to the customer at HLU-231.
NDU $n$ ?	Network Doubler $n$ Loopback	Query to initiate loopback at doubler $n$ to network, where $n$ is the number of the doubler.
NLOC	Network Local Loopback	DSX-1 signal is looped back to DSX-1 at HLU.
NREM	Network Remote Loopback	DSX-1 signal is looped back to DSX-1 at the HRU.
SMJK	Remote SmartJack Loopback	Signal from DSX-1 is looped back at the HRU by the HRU SmartJack module.
<b>DIAGNOSTIC MESSAGES</b>		
1= $xx$ or 2= $yy$	HDSL Loop Margins	Indicates the power of the received HDSL signal on each loop relative to noise. Any value of 06 dB or greater is adequate for reliable system operation.
ACQ1 or ACQ2	Acquisition 1 or 2	The multiplexers of the HLU and the HRU or first doubler are trying to establish synchronization over Loops 1 or 2 of Span 1.
A $n$ L1 or A $n$ L2	Acquisition $n$ Loop 1 or Loop 2	The multiplexers of the two devices on Span $n$ are trying to establish synchronization with each other on Loops 1 or 2, where $n$ is the number of the span.
ARM	HiGain System Armed	Armed to respond to Intelligent Repeater Loop Codes.
BAD RT?	No response from HRU	The HLU does not receive any response from the HRU. Therefore, the integrity of the HRU or the two HDSL loops (they may be open) is questionable.
CODE $xxxx$	Line Code: AMI, B8ZS, AUTO	The line code that HLU-231 List 8A is receiving at its DSX-1 interface, if the DS1 option is set to Auto. Otherwise, it mimics either of the other two DS1 line code settings, Alternate Mark Inversion (AMI) or Bipolar with 8-zero Substitution (B8ZS). Displayed during System Settings review mode.



**Table 2.** *Front-panel Display Messages (Cont.)*

<b>Message</b>	<b>Full Name</b>	<b>Description</b>
DS0	DS0 Blocked Channels	Indicates status of DS0 blocked channels. NONE indicates no channels are blocked. BLK indicates some channels are blocked.
FERR	Framing Bit Error	Framing bit error occurred at HLU T1 input.
FRM xxxx	Frame: SF, ESF, UNFR, NONE	Defines the type of frame pattern being received from the DSX-1: SuperFrame (SF), Extended SuperFrame (ESF), Unframed (UNFR), or NONE. Displayed during System Settings review mode.
H1ES or H2ES	HDSL CRC Error Channel 1 or Channel 2	HDSL Loop 1 or Loop 2 CRC error.
<i>n</i> HDU	Number of Doublers	This message indicates the number ( <i>n</i> ) of doublers in the circuit.
INSL, then xxDB	Maximum Insertion Loss	The maximum Insertion Loss message (INSL) appears followed by xxDB, where xx is the maximum insertion in dB of all spans and loops.
LBPV	Local Bipolar Violation	A bipolar violation has been received at the T1 input to the HLU-231.
LIST xxxx	HLU-231 List Number	The software list number (xxxx) appears during the System Settings review mode. Press the MODE button for 3 seconds to display the list number.
MNGD	Managed	The HLU is under control of the HMU-319 network management unit. In this state, the front-panel craft port and push buttons are disabled.
PWR FEED GND	Power Feed Ground	One of the HDSL loops has been grounded.
PWR FEED ON	Power Feed On	Indicates that the HDSL loops are not grounded or shorted.
PWR FEED OFF	Power Feed Off	HDSL span power has been turned off by setting the PWFD option to DIS, or HDSL span power has been turned off by use of the A1LB/A2LB/A5LB Intelligent Office Repeater (IOR) Power Down code.
PWRF SHRT	Power Feed Short	Indicates a short between the two HDSL pairs. This same message can occur with an HRU that is drawing the correct amount of power over good cable pairs but cannot communicate with the HLU.
SELF TEST	Self Test	The HLU is in a self-test mode. This occurs every power On/Off cycle.
SIG1 or SIG2	Signal 1 or Signal 2	The transceivers of the HLU and HRU or first doubler are trying to establish contact with each other on Loop 1 or Loop 2 of Span 1.
<i>S<sub>n</sub>L1</i> or <i>S<sub>n</sub>L2</i>	Signal <i>n</i> Loop 1 or Loop 2	The transceivers of the two devices on Span <i>n</i> are trying to establish contact with each other on Loop 1 or Loop 2, where <i>n</i> is the number of the span.
TLOS	Transmit Loss of Signal	DSX-1 signal is looped back to the DSX-1 interface at the HRU. HRU is in a logic loopback state caused by a loss of its DS1 input from the CI, if enabled at the HRU by its TLOS switch option.
VER xxxx	HLU-231 Version Number	The software version number (xxxx) appears during the System Settings review mode. Press the MODE button for 3 seconds to display the software version.

# INSTALLATION



Upon receipt of the equipment, visually inspect the contents for signs of damage. If the equipment has been damaged in transit, immediately report the extent of damage to the transportation company and to PairGain Technologies.



When installing an HLU in a chassis, be sure to wear an antistatic wrist strap. Avoid touching components on the circuit board.

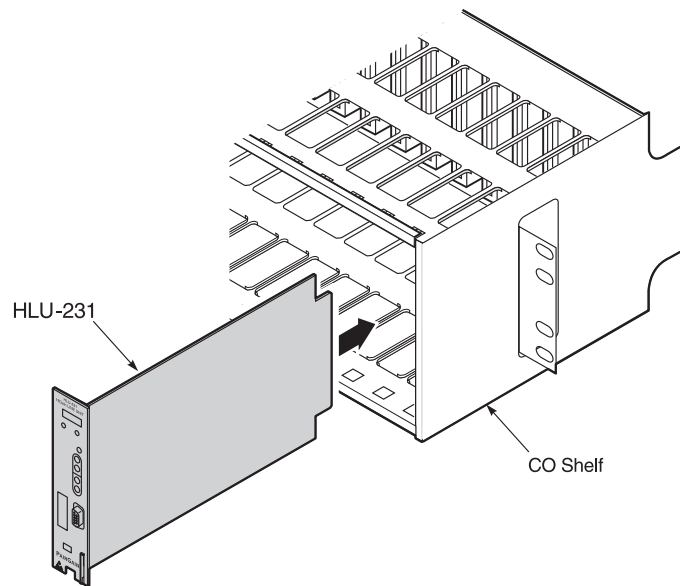

**Figure 2.** *Installing the HLU-231 List 8A into a Shelf*

- 1 Slide the HLU-231 into the card guides of the desired slot, then push the unit back until it touches the backplane card-edge connector and the retaining latch on the front panel opens (Figure 2).
- 2 Place your thumbs on the HLU-231 front panel and push the HLU-231 into the card-edge connector until the retaining latch closes. This indicates that the card is properly seated.

## VERIFICATION

Once the HLU-231 is installed, verify that it is operating properly. To do this, you need to monitor the following:

- Status LED
- Status messages reported by the front-panel display (see [Table 2 on page 6](#))

### Verification without a Downstream Device

If there is no downstream device installed:

- 1 Verify that the HLU powers up. (The front-panel display illuminates and reports four-character status messages. See [Table 2 on page 6](#) for a list of messages.)
- 2 Verify that the HLU attempts to communicate with downstream devices. Even if a downstream device is not present, the following events should occur:
  - a The front-panel display reports four-character status messages.
  - b The HLU enters self-test mode (Status LED is yellow).
  - c The HLU again attempts communication with downstream devices, repeating events **a** through **b** until a downstream device is detected.

### Verification with a Downstream Device

If a downstream device has been installed:

- 1 Verify that the HLU powers up. (The front-panel display illuminates and reports status messages.)
- 2 Verify that the HLU attempts to communicate with downstream devices (status LED flashes red). One of the following occurs:
  - If downstream devices are successfully identified and the HDSL loops synchronize, the HLU status LED will be a steady green. The HLU reports normal margin messages on the front-panel display.
  - If downstream devices are not successfully identified, the HLU reports four-character status messages and enters self-test mode. The HLU successively:
    - a enters self-test mode
    - b completes self-test mode
    - c attempts communication again
    - d reports four-character status messages

The HLU repeats this cycle until a downstream device is detected.

- 3 If there is more than one span, verify that each subsequent span synchronizes normally by monitoring the front-panel display messages.
- 4 If a remote unit is installed, verify that the last span synchronizes normally. The HLU status LED should be a steady green, and the front-panel display should report normal margin messages.
- 5 Verify that a valid T1 signal has been applied to the HLU and the HRU.
  - If no T1 signal is being applied to either the HLU or the HRU inputs, then the appropriate T1 alarms (LLOS or RLOS) are observed on the front-panel display and the status LED flashes red.
  - If a valid T1 signal is being supplied to the HLU and HRU, then T1 alarm indications should be absent and the status LED should be a steady green.

## PROVISIONING REQUIREMENTS

Refer to “[Provisioning](#)” on page 11 for information about using the MODE and SEL buttons or the Maintenance Terminal screens to configure the HLU. While the MODE and SEL buttons can be used to manually accomplish some provisioning tasks, such as setting system options, the Maintenance Terminal screens (available when you connect a PC to the craft port) can handle all provisioning tasks. Tasks that you need to complete are:

- 1 Set the time and date (see “[Set Clock Screen](#)” on page 19).
- 2 Set the circuit IDs (see “[View System Inventory Screen](#)” on page 35).

Assuming that the HLU has been successfully installed and provisioned, you should do the following to ensure an accurate Alarm History and Performance History.

- 1 Clear the Span Status, Performance Data, and Performance History screens. This can be accomplished by pressing **C** (clear) at the Span Status screen (see “[View Span Status Screen](#)” on page 15).
- 2 Clear the Alarm History screens (see “[View Alarm History Screen](#)” on page 33).

# PROVISIONING

This is a reference section for HLU provisioning. There are two methods for provisioning the HLU-231 List 8A:

- Use the MODE and SEL buttons on the front panel of the HLU to:
  - set system options
  - reset the HLU to its factory default settings for system options
  - display system option settings (scroll mode)
  - select system loopbacks
- Use a maintenance terminal (ASCII terminal or a PC running terminal emulation software) connected to the HLU craft port to access the Maintenance Terminal Main Menu (Figure 3 on page 14). This gives you full access to all HLU status, history, inventory, and provisioning screens.



**No dip switches or jumpers are required to provision the HLU-231 as it contains a non-volatile RAM (NVRAM) which stores the system option settings. System option settings are retained if shelf power is lost or if the HLU-231 is unplugged.**

## USING THE MODE AND SEL BUTTONS

### Setting Options through MODE and SEL

To provision the HLU-231 List 8A through the MODE and SEL buttons on the front panel:

- 1 Press the MODE button for 2 seconds and then release it. The front-panel display alternately shows the first system parameter and its current setting.
- 2 Press the SEL button to step through all possible settings (one at a time) of the selected parameter.
- 3 After the desired setting has been selected, press the MODE button. This updates the current displayed parameter to the selected setting, and then advances to the next configurable parameter. After the last parameter has been selected, a CONF NO message appears on the front-panel display.
- 4 Do one of the following:
  - To cancel the session without saving the requested parameter changes, press the MODE button, or do nothing. (After 30 seconds, the display returns to its normal mode without saving the new changes.)
  - To accept the requested parameter changes, press the SEL button. A CONF YES message displays, and the display returns to its normal mode after saving the new changes.

## Resetting to Factory Default Values

All user options (Table 8 on page 21) can be set to the factory default values using the MODE and SEL buttons. To set the user options to their default values:

- 1 Press the SEL button for 6 seconds until the following message appears:

DFLT NO

- 2 Press the SEL button while the DFLT NO message is displayed.

The message changes to DFLT YES indicating the factory default values are now in effect and the display returns to the normal mode.

To terminate the DFLT mode without setting the factory default values, do one of the following:

- Press the MODE button to return to the normal display mode
- Wait 30 seconds for the unit to return to the normal display mode.

## Displaying System Parameter Settings

To scroll through the current settings of all system parameters, press the MODE button for 3 or more seconds. The following parameters are displayed:

- HLU software version number
- HLU List number
- Type of frame pattern being received from the DSX-1
- Line code of the signal being received from the DSX-1 (see note)
- HDSL power level setting
- All user-configured parameter settings



**The line code parameter is the actual DSX-1 line code being received by the HLU if the DSX-1 code pattern is set to AUTO. Otherwise, the line code parameter mimics either of the other two line code settings, Alternate Mark Inversion (AMI) or Bipolar with 8-Zero Substitution (B8ZS).**

## Disabling an Alarm

If the system is in a Minor alarm state, the alarm relay can be disengaged by pressing the SEL button. This turns off the Alarm Cut-off (ACO) indication.

## Loopback Modes

See “Loopback Operation” on page 43 for instructions on using the MODE and SEL buttons to activate loopbacks.

# USING A MAINTENANCE TERMINAL

## Connecting to a Maintenance Terminal

The craft port on the front panel allows you to connect the HLU-231 to a maintenance terminal (ASCII terminal or PC running a terminal emulation program). Once connected to a maintenance terminal, you can access the maintenance, provisioning, and performance screens.

To connect to a maintenance terminal:

- 1 Connect a standard 9-pin terminal cable to the RS-232 craft port (Figure 1 on page 4) on the HLU-231 front panel.
- 2 Connect the other end of the cable to the serial port on the maintenance terminal.
- 3 Start a terminal emulation program such as ProComm (emulating a VT-100 terminal).
- 4 Configure the maintenance terminal to the following communication settings:
  - 1200 to 9600 baud (9600 baud is recommended)
  - no parity
  - 8 data bits
  - 1 stop bit
  - hardware flow control to OFF
- 5 Press the **SPACEBAR** several times to initiate the autobaud connection and to initialize the Maintenance Terminal screens.

## Accessing the Maintenance Terminal Screens

The following sections describe how to use the Maintenance Terminal screens to view, provision and diagnose an HLU-231 List 8A system.

### Navigation Keys

Table 3 lists keys you can use on the maintenance terminal to navigate the Maintenance Terminal screens.

*Table 3. Navigational Keys on the Maintenance Terminal*

Key	Function
<b>A</b>	Automatically updates the screen data
<b>U</b>	Updates screen data
<b>C</b>	Clears screen data
<b>S</b>	Selects the next Span Status screen (for doubler applications)
<b>1</b> , <b>2</b> , <b>3</b> , <b>4</b> , or <b>5</b>	Selects a specific Span Status screen (for doubler applications)
<b>P</b>	Selects the previous page of screen data
<b>N</b>	Selects the next page of screen data
<b>E</b>	Exits the current screen
<b>L</b>	Selects the Loopback menu from the Troubleshooting screen
<b>B</b>	Returns to the main Troubleshooting screen from the Troubleshooting (H)elp, (M)argin Values or (I)nsertion Loss screens

## Maintenance Terminal Main Menu

Figure 3 shows the Maintenance Terminal Main Menu from which you can access system administration screens. The function of each screen selection is listed in Table 4. To access a screen, type the letter shown next to the menu item.

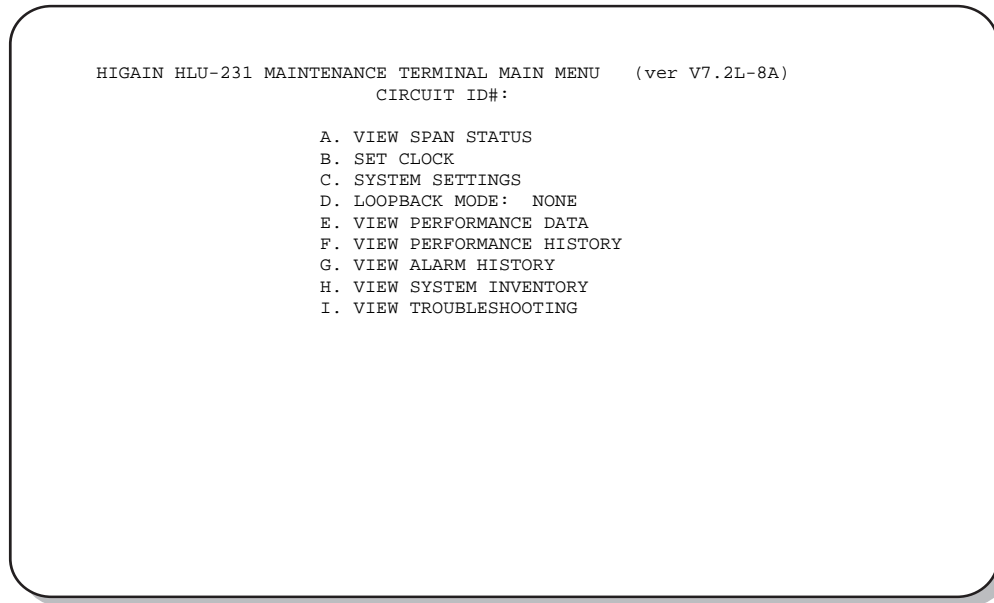

**Figure 3.** Maintenance Terminal Main Menu

**Table 4.** Maintenance Terminal Screens

Press Key	To View Screen	Screen Description	See page:
<b>A</b>	View Span Status	Provides access to subscreens that allow you to monitor the HDSL and T1 line status between the HLU and the HRU.	15
<b>B</b>	Set Clock	Allows you to set both the time and the date parameters at the HLU, and to update the same settings at the HRU.	19
<b>C</b>	System Settings	Allows you to set all user options.	20
<b>D</b>	Loopback Mode	Provides access to a subscreen that allows you to enable and disable loopbacks at both the network and customer side.	26
<b>E</b>	View Performance Data	Provides access to subscreens that allow you to view the Errored Seconds (ES) and Unavailable Seconds (UAS) between the HLU and the HRU in 15-minute intervals over a 4-hour time period per screen for a total of 24 hours (6 screens).	29
<b>F</b>	View Performance History	Provides access to subscreens that allow you to view the ES and UAS between the HLU and the HRU in 24-hour intervals over a 31-day period.	31
<b>G</b>	View Alarm History	Provides access to subscreens that allow you to view alarm conditions between the HLU and the HRU.	33
<b>H</b>	View System Inventory	Allows you to enter a unique circuit ID (up to 24 alpha-numeric characters).	35
<b>I</b>	View Troubleshooting	Provides a graphical analysis of the circuit and identifies problem areas.	37



## Selecting a Maintenance Terminal Function

To perform a function within the Maintenance Terminal screens, you can:

- Press the key indicated to the left of the selection.
- Press the letter in parenthesis for the parameter to be changed.

## System Spans

As shown in [Figure 4](#), the HLU can support up to four doublers with five HDSL spans. The Span Status, Performance Data, and Performance History may display as many five screens to depict an HLU-231 List 8A system.

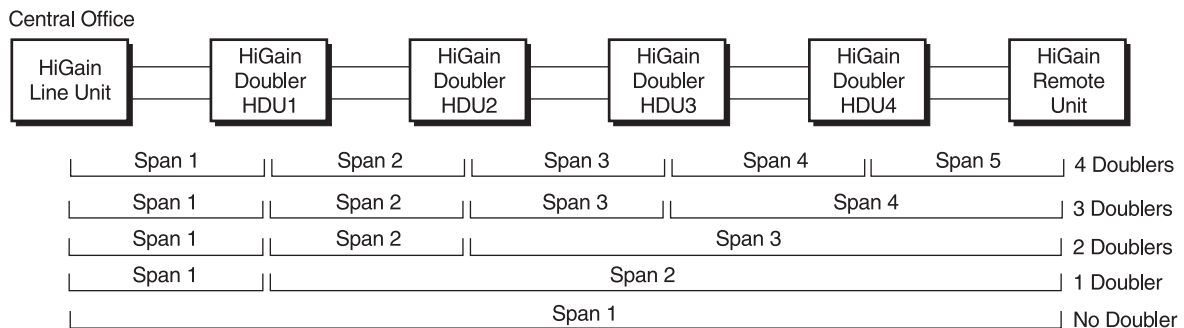

*Figure 4. System Spans*

## USING THE MAINTENANCE TERMINAL SCREENS

### View Span Status Screen

The View Span Status option allows you to view up to five system status screens that provide information about the HDSL Loop 1, HDSL Loop 2, and the DS1. For doubler applications, the available Span Status screens depend on whether the system includes one, two, three, or four doublers.

Press **A** from the Maintenance Terminal Main Menu to open the Span Status screen ([Figure 5 on page 16](#)). If no doubler (HDU) is present, the screen reports span status for the subscriber lines between the HLU and the HRU.

If there are additional doublers, the Span Status screen reports status on each span. [Figure 6 on page 16](#) shows status between HDU4 and the HRU in a system with four doublers. See [Table 5 on page 17](#) for an explanation of the Span Status fields.

From each Span Status screen you can:

- Press **C** to clear the cur (current), min (minimum) and max (maximum) numeric counts. This also clears the Performance History and Performance Data screens.
- Press **A** to automatically update status screens. (Press **A** again to turn off auto update.)
- Press **U** to update cur (current) values.
- Press **S** to view the next available span (for doubler applications).
- Press **E** to exit and return to the previous screen.
- Press **1**, **2**, **3**, **4**, or **5** to select a specific span (for doubler applications).

### Span Status Screen without Doublers

```

                                SPAN STATUS
TIME: 00:27:25
DATE: 08/05/99
ALARMS: NONE
LOOPBACK: OFF
POWER LEVEL: LOW
                                CIRCUIT ID#:

                                HLU                                HRU
                                HDSL-1  HDSL-2  HDSL-1  HDSL-2
                                cur/min/max cur/min/max cur/min/max cur/min/max
MARGIN:                21/20/22  23/22/24  21/19/22  22/21/24 dB
PULSE ATTN:            00          00          00          00 dB
INS LOSS:              00          00          00          00 dB
24 HOUR ES:           00004      00003      00006      00007 seconds
24 HOUR UAS:          00014      00013      00000      00001 seconds

                                DS1 STATUS
24 HOUR ES Count:      HLU          HRU
24 HOUR UAS Count:    00001      00002
Frame type:           SF          SF
Code type:            AMI         AMI

AUTOUPDATE OFF                (E)xit (C)lear (A)uto(U)pdate
    
```

Figure 5. Span Status Screen: No Doubler

### Span Status Screen for Doubler Applications

If doublers have been added, status is also reported for these. Span Status can have up to five screens, depending on the number of HDUs.

```

                                SPAN 5 STATUS
TIME: 12:06:04
DATE: 08/05/99
ALARMS: NONE
LOOPBACK: OFF
POWER LEVEL: HIGH
                                Circuit ID#:

                                HDU4                                HRU
                                HDSL-1  HDSL-2  HDSL-1  HDSL-2
                                cur/min/max cur/min/max cur/min/max cur/min/max
MARGIN:                23/23/23  23/21/23  24/20/25  24/21/24 dB
PULSE ATTN:            07          07          07          07 dB
INS LOSS:              08          08          08          08 dB
24 HOUR ES:           00010      00008      00001      00002 seconds
24 HOUR UAS:          00021      00020      00004      00002 seconds

                                DS1 STATUS
24 HOUR ES Count:      HLU          HRU
24 HOUR UAS Count:    00000      00017
Frame type:           ESF         ESF
Code type:            AMI         AMI

AUTOUPDATE OFF                (E)xit (C)lear (A)uto(U)pdate (S)pan(1)(2)(3)(4)(5)
    
```

Figure 6. Span Status Screen: Four Doublers (Span 5)

Table 5 lists the Span Status fields and descriptions. Table 6 and Table 7 on page 18 describe alarm and loopback messages displayed on the Span Status screens.

**Table 5. Span Status Fields and Descriptions**

Span Status Field	Description
Time	Time of day when Span Status was checked.
Date	Date when Span Status was checked.
Circuit ID#	Shows the user-defined circuit ID.
Alarms	Presence or absence of alarm conditions. See Table 12 on page 41.
Loopback	Indicates Off condition or identifies specific active loopback. See Table 13 on page 44.
Power Level	Indicates the HDSL line voltage in its Low (-140 Vdc) or High ( $\pm 112$ Vdc) state.
Margin	Indicates the excess signal to noise ratio at all HDSL ports, relative to a $10^{-7}$ Bit Error Rate. <ul style="list-style-type: none"> <li>• First value is current margin.</li> <li>• Second value is minimum margin since last cleared.</li> <li>• Third value is maximum margin since last cleared.</li> <li>• N/A means that the margin is not available.</li> </ul> <p>The minimum and maximum margins are cleared and updated every time the Span Status screen is cleared and every time the system clock passes 12:00 AM midnight.</p>
Pulse ATTN	Indicates the attenuation of the 2B1Q pulse from the distant end. The value is related to the 196 kHz loss of the cable pair. The pulse attenuation is a more direct indication of the loop attenuation to the 2B1Q signal than is the 196 kHz loss. The normal HiGain ATTN operation range is from 0 to 28 dB.
INS Loss	Indicates the approximate insertion loss of the loops at the HDSL line rate of 196 kHz. It is generated by multiplying the pulse attenuation by 1.25. Normal range is 0 dB to 35 dB.
24-Hour ES	The number of one second intervals that contained at least one CRC error. This value is a running total of the last 24 Hours.
24-Hour UAS	The number of seconds the HDSL loop was out of sync.
24-Hour ES Count	The number of seconds in which at least one error was detected on the DS1 input over a 24-hour period. Errors included are: DS1 Frame errors; and UAS, BPV, and ESF CRC errors.
24-Hour UAS Count	The number of seconds during which the DS1 input signal was absent ( $175 \pm 75$ consecutive zeroes) over a 24-hour period.
Frame type	Type of DS1 framing used on the input stream (SF or ESF).
Code type	Type of DS1 line coding used (AMI, B8ZS, AMI: ZBTSI, or B8ZS: ZBTSI). The latter two indicate the code type that is being received when HiGain line is set to ZBTS1 mode. When set to AMI or B8ZS, the HLU displays the selected code rather than the code type that is actually being received.



The Span Status screens shown on the previous page display a four-character code under the Alarms entry. These codes are described in Table 6 on page 18.

The following codes are reported with a RCV or XMT prefix that indicates the signal is being transmitted or received: LLOS, RLOS, LAIS, or RAIS.

**RCV (xxxx) - Signal received (xxxx) at the T1 input to either the HLU or HRU.**

**XMT (xxxx) - Signal transmitted (xxxx) at the T1 output of either the HLU or HRU.**

**Table 6. HDSL System Alarms**

Message	Name	Description
BER	Bit Error Rate	The Total System Error Count (TSEC) has exceeded the user-selected threshold.
LOSW	Loss of Sync Word	One of the HDSL loops has lost synchronization.
LLOS	Local Loss of Signal	No signal from HLU-231 List 8A local T1 input.
MAL1 or MAL2	Margin Alarm 1 or Margin Alarm 2	The margin on the HDSL Loop 1 or Loop 2 has dropped below the threshold (1 to 15 dB) set by the user. Setting the threshold to zero inhibits the margin alarm.
NONE	No Alarm	No alarm is indicated.
RAIS or LAIS	Remote (or Local) Alarm Indicating Signal	Indicates an AIS pattern of all ones is being transmitted from the remote (or local) T1 output port.
RLOS	Remote Loss of Signal	Indicates that no signal is detected at the DS-1 input to the HRU.

Table 7 lists loopback messages displayed on the Span Status screens. For information about loopback codes, see “GNLB Test Procedures” on page 47.

**Table 7. Loopback Messages**

Message	Full Name	Description
ARM	Armed	The HiGain system has detected the Intelligent Repeater (IR) loopback arming code (2-in-5).
CDU $n$	Customer Doubler $n$ Loopback	Loopback at Doubler ( $n$ ) to Customer Installation (CI) initiated by an Intelligent Line Repeater (ILR) code, the MODE and SEL buttons on HLU-231 front panel, or by the maintenance terminal.
CHREV-SP $x$	Channels Reversed	The Loop 1 and Loop 2 HDSL pairs are reversed at Span $x$ . Loop 1 is specified to carry the (-) simplex DC voltage, and Loop 2 is specified to carry the (+) simplex DC voltage. SP $x$ indicates that the first occurrence of a reversed span is on Span $x$ , where $x$ is the number of the span.
CLOC	Customer Local Loopback	Loopback at HRU (local) to CI initiated from Customer Premises Equipment (CPE) by the ILR #2 code, the MODE and SEL buttons on the HLU-231 front panel, or by the maintenance terminal.
CREM	Customer Remote Loopback	Loopback at HLU-231 (remote) to customer initiated by Intelligent Office Repeater (IOR) code, the MODE and SEL buttons on the HLU-231 front panel, or by the maintenance terminal.
(HG)	HiGain	The loopback was initiated from a HiGain front panel or by a HiGain maintenance terminal loopback command.
NDU $n$	Network Doubler $n$ Loopback	Loopback at Doubler ( $n$ ) to network initiated by ILR code, by the MODE and SEL buttons on the HLU-231 front panel, or by the maintenance terminal.
NLOC	Network Local Loopback	Loopback HLU-231 (local) to network initiated from CO by IOR code, the MODE and SEL buttons on the HLU-231 front panel, or by the maintenance terminal.
NREM	Network Remote Loopback	Loopback at HRU to network initiated from CO (network) by ILR #2 code, the MODE and SEL buttons on the HLU-231 front panel, the HRU manual loopback button, or by the maintenance terminal.
OFF	Off	No active loopback mode.
(PL)	Pay Load	The loopback was initiated by a command that was embedded in the T1 data path.
SMJK	SmartJack Loopback	Loopback from HRU to network initiated by (2-in-5) inband loopback code or out-of-band ESF data link code.
TLOS	Transmit Loss of Signal Loopback	HRU is in a logic loopback state caused by a loss of its T1 input from the CI (if enabled at the HRU through its TLOS switch option).

## Set Clock Screen

Press **B** at the Maintenance Terminal Main Menu to open the Set Clock screen (Figure 7).



*Figure 7. Set Clock Screen*



**All time information is lost when power is removed. The last date, however, is retained in NVRAM and reappears when power is restored.**

### Set Time

The cursor defaults to the New Time field. To set the system time, type the hour and minute in the 24-hour format of **hh:mm:ss** (setting the seconds is optional), then press **ENTER**. The New Date field appears.

### Set Date

To set the system date, type the month, day and year in a **mm/dd/yy** format, then press **ENTER**. The Update Remote field appears.



**When editing entries in the Set Clock screen and when using the Terminal emulation program in Windows 3.1, pressing the **BACKSPACE** key deletes two characters instead of just one.**

### Update the HRU Time and Date

The remote unit date and time is set by using this option. Do one of the following:

- Press **U** to update the HRU to the same date and time set for the HLU-231.
- Press **ENTER**. (The date and time are not updated.)

## System Settings Screen

The options set from the System Settings screen are the same as the options set through the HLU-231 Mode and SEL buttons on the front panel. The exceptions are Margin Alarm Threshold and DS0 Blocking, which can only be set at this screen. Refer to [Table 8 on page 21](#) for a listing of system setting options.

Press **C** at the Maintenance Terminal Main Menu to open the System Settings screen ([Figure 8](#)).

```

                                SYSTEM SETTINGS

TIME: 12:46:06
DATE: 08/05/99                                CIRCUIT ID#:

A. EQUALIZATION....: 0                        P. MARGIN ALARM THRESH : 4
B. SMARTJACK LPBK.: ENABLED                    Q. RLOS (DS1 LOS) ALARM: ENABLED
C. SPECIAL LPBK....: GNLB                      R. ALARM PATTERN.....: AIS
F. POWER.....: AUTO                          S. REMOTE PROVISIONING : ENABLED
G. ZBTSI.....: OFF                            T. BPVT.....: DISABLED
H. BER ALARM THRESH: NONE
I. LOOPBACK TIMEOUT: 60
J. ALARM.....: DISABLED
K. DS1 LINE CODE...: AMI
L. FRAMING.....: AUTO
M. AIS ON HDSL LOSW: 2 LOOPS
N. AIS ON SMJK/NREM: ENABLED

                                O. DS0 BLOCKING: xx = Blocked Channels
01 02 03 04 05 06 07 08 09 10 11 12 13 14 15 16 17 18 19 20 21 22 23 24

                                (D)efaults, (E)xit
                                Enter the option letter to change setting

```

**Figure 8.** System Settings Screen

You have the following options at the Systems Settings screen:

- Press the desired option letter to change that setting.
- Press **D** to set all user options to the factory default values.
- If changes were made, press **C** when exiting to confirm, or press any other key to ignore changes.
- Press **E** to exit and return to the main menu.

Table 8 describes the System Settings options and lists the corresponding front-panel display codes. Factory default parameters appear in boldface type.

**Table 8. HLU-231 List 8A System Settings**

System Settings Screen Options	Front-panel Display Code	Parameter	Description
Equalization	EQL	EXT	Disables the HLU internal equalizer, allowing connection of external equalizer hardware to perform the same or a similar function.
		<b>0</b>	Sets the Equalizer to DSX-1 for 0 to 133 feet.
		133	Sets the Equalizer to DSX-1 for 133 to 266 feet.
		266	Sets the Equalizer to DSX-1 for 266 to 399 feet.
		399	Sets the Equalizer to DSX-1 for 399 to 533 feet.
		533	Sets the Equalizer to DSX-1 for 533 to 655 feet.
SmartJack Loopback	LBPk	DIS	Configures the HiGain system to ignore all inband SmartJack loopback commands.
		<b>ENA</b>	Enables the HiGain system to recognize all inband SmartJack loopback commands.
Special Loopback	SPLB	<b>GNLB</b>	Configures the HiGain system to respond to the generic (3-in-7 or 4-in-7) inband loopback codes.
		A1LB and A2LB	Configures the HiGain system to respond to the inband loopback codes of the Teltrend addressable repeater.
		A3LB	Configures the HiGain system to respond to the inband loopback codes of the Wescom addressable repeater.
		A4LB	Configures the HiGain system to respond to the inband loopback codes of the Wescom Mod 1 addressable repeater.
		A5LB	Configures the HiGain system to respond to the inband loopback codes of the Teltrend Mod 1 addressable repeater.
Power (See "HDSL Line Voltage Options" on page 25.)	PWRF	DIS	Disables powering to the HDSL pair.
		LOW	Keeps the HDSL line voltage at -140 Vdc maximum for all applications.
		<b>AUTO</b>	Allows the HDSL line voltage to automatically switch between -140 Vdc maximum for non-doubler applications and $\pm 112$ Vdc for doubler applications.
		HIGH	Forces the HDSL line voltage to $\pm 112$ Vdc for all applications.
ZBTSI	ZBTS	ON	Tells the HiGain system that the ESF frame is operating in its Zero-Byte Timeslot Interchange (ZBTSI) mode.
		<b>OFF</b>	Tells the HiGain system that the ESF frame is operating in its normal non-ZBTSI mode.
BER Alarm Threshold (See "BER Option" on page 24.)	BERT	1E-6	Activates (closes) the system alarm relay contacts on pins 20 and 21 of the card-edge connector and flashes the red Status LED when the BER exceeds $10^{-6}$ .
		1E-7	Activates (closes) the system alarm relay contacts on pins 20 and 21 of the card-edge connector and flashes the red Status LED when $10^{-6} > \text{BER} > 10^{-7}$ .
		<b>NONE</b>	Prevents generation of a system alarm due to BER.
Loopback Timeout	LBTO	NONE	Disables automatic time-out cancellation of all loopbacks.
		20	Sets automatic cancellation of all loopbacks to 20 minutes after initiation.
		<b>60</b>	Sets automatic cancellation of all loopbacks to 60 minutes after initiation.
		120	Sets automatic cancellation of all loopbacks to 120 minutes after initiation.

Table 8. HLU-231 List 8A System Settings (Cont.)

System Settings Screen Options	Front-panel Display Code	Parameter	Description
Alarm	ALM	<b>DIS</b>	Opens the system alarm relay contacts if closed, and disables activation of the system alarm relay when a system alarm condition occurs.
		ENA	Enables activation of the system alarm relay when a system alarm condition occurs.
DS1 Line Code (See “DS1 Line Code Option” on page 24.)	DS1	AUTO	The HLU and HRU monitor the incoming T1 bit streams for the B8ZS line code. If the HRU detects this code, the HLU enters B8ZS output mode. The HLU reverts back to AMI output mode if no B8ZS codes are received at the HRU input for 5 seconds. Similarly, when the HLU detects the B8ZS code, the HRU enters the B8ZS mode and returns to AMI mode if no B8ZS code is received at the HLU input for 5 seconds.
		B8ZS	Places both the HLU and HRU into their B8ZS modes.
		AMI	Places both the HLU and HRU into their AMI modes.
Framing	FRMG	<b>AUTO</b>	Configures the HiGain system to operate in an auto-framing (AUTO) mode in which it continuously searches the input T1 bit stream for a valid SF or ESF frame pattern. This feature is required for fractional T1 applications (DS0 blocking) where it insures proper channel time slot alignment. While the HiGain system can also process unframed data in this AUTO mode, it is recommended that the unframed (UNFR) mode be used for all unframed applications. Using the AUTO mode for unframed applications runs the risk of detecting pseudo-valid frame sequences, which can affect the data integrity.
		UNFR	Configures the HiGain system to operate in an unframed mode. This mode disables the auto framing process and forces the HiGain system to function as a transparent bit pipe.
AIS on HDSL LOSW (See “HAIS Option” on page 25.)	HAIS	<b>2LP</b>	Causes the HiGain system to transmit the AIS signal at both the HLU-231 and HRU T1 output ports when both of the HDSL loops are not in sync (LOSW).
		1LP	Causes the HiGain system to transmit the AIS signal at both the HLU-231 and HRU T1 output ports when either of the two HDSL loops is not in sync (LOSW) or if a Margin alarm occurs.
AIS on SMJK/NREM	SAIS	<b>ENA</b>	Causes the HRU to transmit the AIS signal towards the Customer Interface (CI) when in NREM or SmartJack loopback.
		DIS	Causes the HRU to either transmit the signal from the network towards the CI RCV port or to open and terminate its RCV CI port when an HRU NREM or SmartJack loopback is executed. The AIS signal is not sent (towards the CI).
DS0 Blocking (See “DS0 Blocking Option” on page 24.)	DS0	BLK	The DS0 blocking option can only be set through a maintenance terminal connected to the craft port. The four-character front-panel display only shows the status of the blocking option. BLK indicates at least one channel is blocked.
		<b>NONE</b>	Indicates no channels are blocked.
Margin Alarm Threshold (See “Margin Alarm Threshold Option” on page 25.)	MARG	0 to 15 dB	The Margin Alarm Threshold can only be set through a maintenance terminal connected to the craft port. It determines the minimum allowable margin below which a system alarm can occur. Zero disables the alarm.
		<b>4dB</b>	Default value.
RLOS Alarm	RDA	<b>ENA</b>	Enables a remote DS1 LOS condition at the input to the HRU to generate an LOS alarm. AIS or LOS (depending on ALMP) is sent towards the network.
		DIS	Prevents a remote DS1 LOS condition at the input to the HRU from causing an LOS alarm. The front-panel Status LED still flashes red and the ALRM RLOS message is displayed but the alarm relay contacts do not close and LOS is sent towards the network from the HLU instead of AIS.



**Table 8. HLU-231 List 8A System Settings (Cont.)**

System Settings Screen Options	Front-panel Display Code	Parameter	Description
Alarm Pattern	ALMP	<b>AIS</b>	Enables HiGain to output an AIS payload at its T1 ports for LOSW, T1 LOS and Margin alarms.
		LOS	Enables HiGain to output an LOS condition at its T1 ports for LOSW, T1 LOS and Margin alarms.
Remote Provisioning	RTPV	<b>ENA</b>	Enable remote provisioning.
		DIS	Disable remote provisioning.
Bipolar Violation Transparency (See "BPVT Option" below.)	BPVT	<b>ENA</b>	Enables BPVs and HDSL CRC errors at the T1 input to be converted into T1 BPVs at the distant end's T1 output. This makes HiGain transparent to BPVs.
		<b>DIS</b>	Disables BPVT.
Confirm Settings	CONF	<b>YES</b>	Confirms that all operating modes are to be updated to their current selections.
		<b>NO</b>	Prevents the most recently selected operating mode selections from being updated. They remain as they were before the system option settings mode was entered.

## Equalization Option

Equalization is the configuration of system transmission characteristics within specified limits. An adaptive equalizer inserts a frequency-shaped loss that corresponds to an equivalent addition of an appropriate cable length. By simulating the additional cable loss necessary for correct operation, the equalizer compensates for a range of variation in transmission path characteristics.

## BPVT Option

The HLU-231 List 8A improves HiGain's compatibility with Digital Loop Carrier (DLC) feeder applications because of its ability to transmit T1 BPV occurrences between its T1 interfaces. This feature is required to support protection switching in DLC applications. Each DLC terminal must be able to monitor the integrity of its Receive T1 payload and then switch to the protected line when the integrity of the path drops below specific user-selected limits. An essential requirement of this feature is the need for each DLC terminal to detect BPVs in its T1 input. Standard HDSL systems correct T1 BPVs at the input and therefore prevent them from being detected by the DLC terminals to which they are connected. The HLU-231 and its associated remote units remove this limitation and become BPV transparent by detecting and counting input BPVs at each end and then replicating them at the T1 output port of the distant end.

This BPVT option is controlled by the BPVT user option, which allows it to be Enabled (ENA) or Disabled (DIS).



**When BPVT is enabled in systems with four or less doublers, the response time to an HDSL LOSW is approximately 70 ms, which gives DLC terminals time to react and avoid dropped calls.**

In addition, the CRCs in each direction of every HDSL loop of each span are also counted and added in with the BPV count to produce a Total Error Count (TEC) that indicates the integrity of both the T1 and HDSL paths. A TEC in each direction is calculated each second by adding the number of BPVs to the number of HDSL CRCs in that direction. The maximum TEC count is 12000. This TEC number is converted into BPVs at the distant end during the following second at a rate of 1 BPV every 128 T1 bits up to a maximum of 12000 ( $BER=7.7 \times 10^{-3}$ ). This maximum rate is more than adequate since it exceeds the maximum  $10^{-3}$  BER required by most DLC systems.

## BER Option

The BER option also uses this (BPV/CRC) TEC to generate an Alarm if enabled. The HLU combines the 1-second TEC counts in both directions for the last 60 seconds. It uses this 1-minute Total System Error Count (TSEC) to generate an alarm if it exceeds the selected BER threshold of (1E-6 or 1E-7) as follows:

- BER option = 1E-6. Alarm is generated if TSEC > 92
- BER option = 1E-7. Alarm is generated if TSEC > 9

Once initiated, the alarm clears when the TSEC drops below its associated threshold count. For dribbling errors, the alarm can come and go in intervals as short as 1 second. Alarms due to bursty impulse noise transients usually require the full 60 seconds or longer to clear depending on the frequency of the transients. This BER option is always present in any line unit circuit since it is independent of other versions of HiGain modules in the circuit. When connected to an HRU, other than the HRU-402, HRU-406, or HRU-411, only the BVPs detected by the HLU are included in the TEC. The BPVs at the HRU are not counted.

## DS0 Blocking Option

To set the DS0 Blocking option from the Main screen:

- 1 Press **C** to select the Systems Settings screen (see [Figure 8 on page 20](#)).
- 2 Press **O** for the DS0 blocking selection. The DS0 channels are blocked or unblocked by entering each channel number. Multiple channels can be selected by inserting a space between each entry.
- 3 After all the new settings have been made, press **E** to (Exit) and then **C** to (Confirm). The new choices are now installed.

If DS0 blocking is invoked in a HiGain system that has an earlier version HRU that does not support the blocking option, blocking only occurs at the DSX-1 output of the HLU-231 List 8A. The HRU DS1 output is not blocked. Also, all blocked channels are temporarily unblocked for all HiGain system loopback tests for all DS1 blocking settings. This allows the standard full bandwidth T1 loopback tests to be performed for all DS0 blocking settings.

If any of the unused DS0 channels of a fractional T1 service are filled with information other than an idle code of all ones, the HiGain system blocks this information from reaching the remote end of the circuit and replaces those DS0 channels with an idle code of all ones.

Blocking the idle code results in a mismatch between the CRC checksum delivered to the remote end (when the payload is in the ESF format) and the checksum calculated by the remote T1 CSU. This implies that errors are being made on the loop when actually the blocking function created the CRC errors. Enabled DS0 channels pass error-free.

In order to avoid this condition, fractional T1 customers should fill the unused time slots with an idle code. This is a common capability on Fractional T1 CSU/DSU, D4 channel banks, and other CPE devices capable of connecting to Fractional T1 service.

## DS1 Line Code Option

The DS1 line code option should always be set to conform to the type of DS1 service (AMI or B8ZS) being provided by the HiGain system. The AUTO mode, which can adapt to either AMI or B8ZS, should only be used in applications that require it (such as when HiGain acts as a standby circuit to DS1 circuits whose line codes are not known or may be both AMI and B8ZS). This is because the AUTO mode induces one BPV in the DS1 bit stream whenever it switches from AMI to B8ZS. The AUTO mode allows both the HLU and the HRU to set its T1 output code to that which is being received at the opposite end's T1 input. This forces the input and the output codes in each direction of transmission to be identical. In the AUTO mode of older HiGain units, the output code was determined by the input code being received at the local T1 input port instead of at the distant end. The HLU reverts to this older code setting technique when it is not connected to an HRU-402 or HRU-411.

## Margin Alarm Threshold Option

To set the Margin Alarm Threshold:

- 1 Select **P** from the System Settings Main Menu screen.
- 2 Enter the desired minimum acceptable alarm threshold from the 0 to 15 dB range. This causes a system alarm to occur if either the margin on HDSL Loop 1 (MAL1) or Loop 2 (MAL2) drops below the selected threshold value.



Since the margin can never drop below zero, choosing **0** (zero) for the margin threshold turns the margin alarm off.

## HAI5 Option

The HAI5 option provides two selections for the T1 transmit outputs at both the HLU-231 and HRU for HDSL loss of sync conditions.

- **1LP** causes the AIS (LOS if ALMP is set to LOS) pattern to be transmitted at both T1 outputs when either of the two HDSL loops experience an out-of-sync (LOSW) condition or when a margin alarm occurs. 1LP causes the 12 channels on the surviving loop to be lost as they are replaced by the AIS/LOS pattern. However, it does not notify downstream and upstream equipment of the loss of one HDSL loop or a loop with low margin. This is the preferred setting for initiating an AIS/LOS state with just one conductor open in either of the HDSL pairs. Short loops, below approximately 16 dB of loss at 200 kHz, can remain in sync with one conductor open. Since the loop is still in sync, no LOSW condition occurs. However, the margin on a one-conductor loop drops from 5 to 10 dB. Therefore, if the Margin alarm is set to 5 dB below the normal margin at turn-up, when one conductor does open, a system alarm occurs and causes the AIS/LOS condition. This alerts the maintenance personnel of the problem.
- **2LP** requires both HDSL loops to be out of sync (LOSW) before the HAI5 signal is transmitted. 2LP preserves the integrity of the 12 surviving channels when just one loop is lost.

## HDSL Line Voltage Options

The PWRF option has four settings for HDSL line power feed: DIS, LOW, AUTO, and HIGH.

- **DIS** disables any voltage from being applied to the HDSL cable pairs. It is useful to prevent craft personnel from being exposed to the HDSL line voltage when they are working on the cable pairs.
- **LOW** limits the HDSL simplex voltage to -140 Vdc maximum. This is the standard voltage used in all non-doubler applications and has no effects in these applications. It can be chosen to limit line-powered, single-doubler circuits or locally-powered, two-doubler circuits up to -140 Vdc, if the appropriate HiGain products (HDU-409, HDU-404 or HDU-407 and HRU-402 or HRU-411) are used along with the HLU-231 List 8A. These HiGain units are the only ones that have sufficiently low power consumption to allow their doubler circuits to be line-powered from -140 Vdc. The HRU-411 must have the CPE power option disabled if it is used in a -140 Vdc doubler circuit.
- **AUTO** is the conventional mode in which the HLU automatically maintains the HDSL line voltage at -140 Vdc maximum for non-doubler applications and  $\pm 112$  Vdc for doubler applications.
- **HIGH** forces the HDSL line voltage to its high  $\pm 112$  Vdc level for applications. It is needed to allow the HLU to power circuits that are providing power to remote Personal Communication Systems (PCS) sites.



If the HLU-231 is used with the HRU-411 to power PCS sites, the PWRF option should be set to AUTO. This causes the HLU to automatically detect the need to switch to the HIGH power feed mode when it receives a request from the HRU to do so.

## Loopback Mode Screen

The Loopback Menu permits you to issue loopbacks to the HiGain system. Depending upon the number of doublers, there can be up to five loopback screens.

Press **D** from the Maintenance Terminal Main Menu to display the Loopback Menu. [Figure 9](#) shows an example of a Loopback Menu when no doublers are present; [Figure 10](#) shows an example when four doublers are present.

The following options are available:

- Type **A** to select the Disable Loopbacks option.
- Type **B** to select HLU Network Loop.
- Type **C** to select HRU Network Loop.
- Type **G** to select HLU Customer Loop.
- Type **H** to select HRU Customer Loop.
- For doubler applications, additional loopback selections appear on the screen.
- Type **E** to exit and return to the previous menu.

[Table 9](#) lists the HLU-231 Loopback field messages and descriptions.

*Table 9. Loopback Field Messages and Descriptions*

Messages	Full Name	Description
NREM	Network Remote Loopback	Loopback at HRU (remote) towards network.
NLOC	Network Local Loopback	Loopback at HLU (local) towards network.
CLOC	Customer Local Loopback	Loopback at HRU (local) towards CI.
CREM	Customer Remote Loopback	Loopback at HLU (remote) towards CI.
NDU $n$	Network Doubler $n$ Loopback	Loopback at $n^{\text{th}}$ doubler towards network.
CDU $n$	Customer Doubler $n$ Loopback	Loopback at $n^{\text{th}}$ doubler towards CI.

## Loopback Menu without Doubler

```

                                LOOPBACK MENU

TIME: 00:15:34
DATE: 08/05/99
CIRCUIT ID#:

      A. DISABLE LOOPBACKS
      B. NETWORK LOOP HLU      (NLOC)
      C. NETWORK LOOP HRU      (NREM)
      G. CUSTOMER LOOP HLU      (CREM)
      H. CUSTOMER LOOP HRU      (CLOC)

      (E)xit

```

*Figure 9. Loopback Menu: No Doubler*

## Loopback Menu for Doubler Applications

```

                                LOOPBACK MENU

TIME: 00:03:33
DATE: 08/05/99
CIRCUIT ID#:

      A. DISABLE LOOPBACKS
      B. NETWORK LOOP HLU      (NLOC)
      C. NETWORK LOOP HRU      (NREM)
      D. NETWORK LOOP DOUBLER 1 (NDU1)
      F. NETWORK LOOP DOUBLER 2 (NDU2)
      G. CUSTOMER LOOP HLU      (CREM)
      H. CUSTOMER LOOP HRU      (CLOC)
      I. CUSTOMER LOOP DOUBLER 1 (CDU1)
      J. CUSTOMER LOOP DOUBLER 2 (CDU2)
      K. NETWORK LOOP DOUBLER 3 (NDU3)
      L. CUSTOMER LOOP DOUBLER 3 (CDU3)
      M. NETWORK LOOP DOUBLER 4 (NDU4)
      N. CUSTOMER LOOP DOUBLER 4 (CDU4)

      (E)xit

```

*Figure 10. Loopback Menu: Four Doublers*

### Initiating a Loopback

To send one of the available loopbacks, press the appropriate letter in the Loopback Menu. The following prompt appears:

PERFORM SELECTED LOOPBACK ( **Y** OR **N** ) ? Type **Y** to continue with the loopback selection. The following message appears:

PLEASE WAIT.....

A series of dots moves from left to right indicating that the command has been issued. When this process completes, the system returns to the Maintenance Terminal Main Menu. The selected loopback four letter designation now appears in the Loopback Mode field in the Maintenance Terminal Main Menu (see [Figure 11](#) in which an NLOC loopback is in progress). The loopback continues to cycle in the system depending upon your Loopback Timeout setting.



**The Loopback Menu screen is also available at the HRU connected to the HLU-231 List 8A, therefore allowing all HiGain System loopbacks to be initiated from either end of the circuit.**

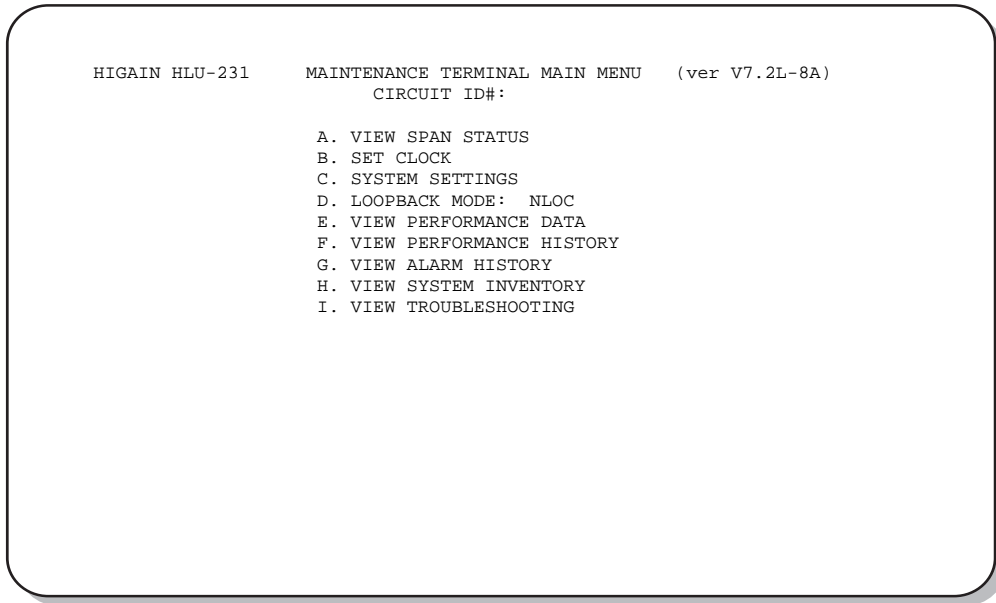

*Figure 11. NLOC Loopback Mode Reported in the Maintenance Terminal Main Menu*

### Disabling a Loopback

The Disable Loopbacks option ([Figure 9 on page 27](#)) allows you to disable (cancel) any of the loopbacks listed in the screen. To disable loopbacks, press **A** in the Loopback Menu. The following prompt appears:

PLEASE WAIT.....

A series of dots moves from left to right indicating that the command has been issued. When this process completes, the system returns to the Maintenance Terminal Main Menu where the Loopback Mode is identified as None.

## View Performance Data Screen

The Performance Data screen shows the Errored (ES) and Unavailable Seconds (UAS) for both HDSL loops and each T1 input at 15-minute intervals over a 4-hour time interval. (The ES and UAS data is separated by a slash mark.) Earlier and later data, in 4-hour time periods on different span screens, can be accessed by pressing **P** (Previous) or **N** (Next) respectively.

Errored and Unavailable seconds are defined in [Table 10](#).

Press **E** at the Maintenance Terminal Main Menu to view the Performance Data screen. From each Performance Data screen you can do the following:

- Press **P** to view the previous 4-hour data screen.
- Press **N** to view the next 4-hour data screen.
- Press **S** to view the next available span (for doubler applications).
- Press **1**, **2**, **3**, **4**, or **5** to select a specific span (for doubler applications).
- Press **E** to exit.



All Performance Data counters can be set to zero by pressing **C** (Clear) from the HLU-231 Span Status screen shown in [Figure 5 on page 16](#). The HLU-231 is considered the master module; it clears all performance data screens at both the HLU-231 and the HRU. Counters can not be cleared by accessing the HRU craft port.

*Table 10. Errored and Unavailable Seconds Definitions*

ES and UAS	Definition
HDSL Errored Second	A second in which at least one HDSL CRC has occurred.
HDSL Unavailable Second	A second in which an HDSL loop experiences loss of sync at least once.
DS1 Errored Second	A second in which at least one BPV, CRC, FRM error, or LOS has occurred.
DS1 Unavailable Second	A second in which at least one T1 LOS condition ( $175 \pm 75$ ) zeros has occurred.

### Performance Data Screen without Doubler

Figure 12 shows a single non-doubler span. This screen shows the Errored and Unavailable Seconds for the HDSL span between the HLU-231 and the HRU. Invalid report entries are indicated by dashes.

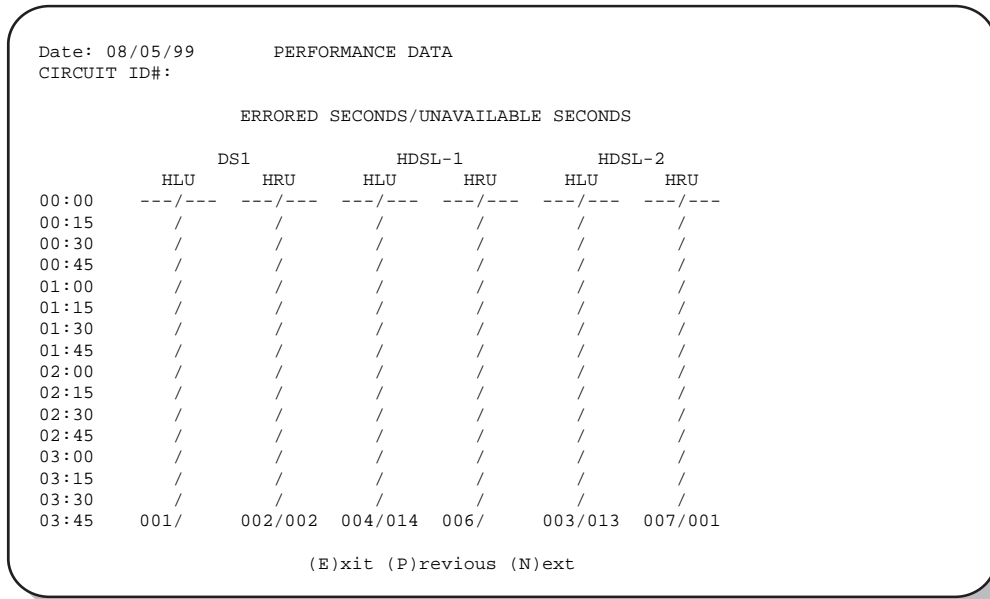

Figure 12. Performance Data Screen: No Doubler

### Performance Data Screen for Doubler Applications

Figure 13 is an example of a Performance Data screen that lists performance data for the fifth span (HDU4 to the HRU). Invalid report entries are indicated by dashes.

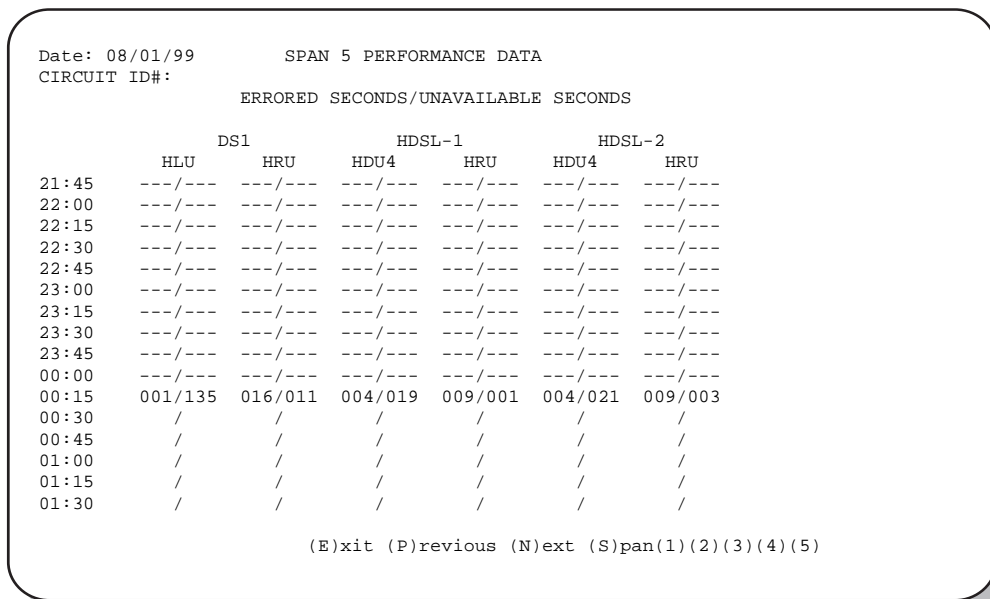

Figure 13. Performance Data Screen: Four Doublers (Span 5)



## View Performance History Screen

The Performance History screen shows the daily occurrences of ES and UAS over a 31-day period in 24-hour increments. Errored Seconds and Unavailable Seconds for both HDSL loops and each of the two DS1 inputs are listed for the current and previous period.

Press **F** at the Maintenance Terminal Main Menu to open the Performance History screen. This screen shows the ES and UAS for the HDSL loop between the HLU-231 and the HRU.

The following options are available:

- Press **S** from the Performance History screen to advance through the history screens for the various spans (for doubler applications).
- From the 31-day Performance History screen press **N** (Next) for a continued history.
- From the 31-day Performance History screen press **P** (Previous) for the previous screen.
- Press **E** to exit from the Performance History screen.



**All Performance History counters can be set to zero by pressing **C** (Clear) from the HLU-231 Span Status screen shown in Figure 5 on page 16. The HLU-231 is considered the master module; it clears all performance data screens at both the HLU-231 and the HRU. Counters can not be cleared by accessing the HRU craft port.**

### Performance History Screen without Doubler

Figure 14 shows a non-doubler application. Invalid report entries are indicated by dashes.

```

Time: 00:27:46                PERFORMANCE HISTORY - 31 DAY
CIRCUIT ID#:
                                ERRORED SECONDS/UNAVAILABLE SECONDS

                                DS1                HDSL-1                HDSL-2
                                HLU        HRU        HLU        HRU        HLU        HRU
01/17  ---/---                ---/---                ---/---                ---/---
01/18  ---/---                ---/---                ---/---                ---/---
01/19  /                    /                    /                    /                    /                    /
01/20  /                    /                    /                    /                    /                    /
01/21  /                    /                    /                    /                    /                    /
01/22  /                    /                    /                    /                    /                    /
01/23  /                    /                    /                    /                    /                    /
01/24  /                    /                    /                    /                    /                    /
01/25  /                    /                    /                    /                    /                    /
01/26  /                    /                    /                    /                    /                    /
01/27  /                    /                    /                    /                    /                    /
01/28  00001/                00002/00002  00004/00014  00006/                00003/00013  00007/00001
01/29  /                    /                    /                    /                    /                    /
01/30  00001/                00002/00002  00004/00014  00006/                00003/00013  00007/00001
01/31  00001/                00002/00002  00004/00014  00006/                00003/00013  00007/00001
current 00001/                00002/00002  00004/00014  00006/                00003/00013  00007/00001

                                (E)xit (P)revious
    
```

**Figure 14.** 31-Day Performance History Screen: No Doubler

### Performance History Screen for Doubler Applications

The Performance History screen displays information by span when doublers are present. With multiple doublers (up to four), there can be as many as five span screens. Invalid report entries are indicated by dashes.

```

Time: 00:26:29          SPAN 5 PERFORMANCE HISTORY - 31 DAY
CIRCUIT ID#:
                ERRORED SECONDS/UNAVAILABLE SECONDS

                DS1                HDSL-1                HDSL-2
                HLU                HRU                HDU4                HDRU                HDU4                HRU
01/17  -----/-----/-----/-----/-----/-----/-----
01/18      /                /                /                /                /                /
01/19      /                /                /                /                /                /
01/20      /                /                /                /                /                /
01/21      /                /                /                /                /                /
01/22      /                /                /                /                /                /
01/23      /                /                /                /                /                /
01/24      /                /                /                /                /                /
01/25      /                /                /                /                /                /
01/26      /                /                /                /                /                /
01/27      /                /                /                /                /                /
01/28      /                /                /                /                /                /
01/29  00001/                /                00005/00415                /                00035/00492                /
01/30      /                /                /                /                /                /
01/31  00001/                00002/00002  00004/00014  00006/                00003/00013  00007/00001
current 00001/                /                00005/00415                /                00035/00492                /

                (E)xit (P)revious (S)pan(1)(2)(3)(4)(5)
    
```

**Figure 15.** 31-Day Performance History Screen: Four Doublers (Span 5)

## View Alarm History Screen

Press **G** at the Maintenance Terminal Main Menu to open the Alarm History screen. This screen allows you to view alarms that are currently active. In the Alarm History screen (Figure 16 and Figure 17 on page 34) the:

- First and Last columns contain the time and date stamp of the first and last occurrence of each alarm.
- Current column shows the status of each alarm.
- Count column lists the number of times each alarm occurred. (The maximum non-overflowing count is 999.)

From each Alarm History screen you can do the following:

- Press **U** to update the screen.
- Press **S** to view another span (for doubler applications).
- Press **C** to clear all data from the screen.
- Press **1**, **2**, **3**, **4**, or **5** to select a specific span (for doubler applications).
- Press **E** to exit from the Alarm History screen.

Table 11 lists the Alarm History fields and descriptions. These descriptions apply to the Alarm History for doubler applications as well.

**Table 11.** Alarm History Fields and Descriptions

Field	Description
Type	Identifies the type of alarm
LOS, DS1-HLU	First and last instance of LOS at the HLU; current condition, number of alarms
LOS, DS1-HRU	First and last instance of LOS at the HRU; current condition, number of alarms
BER	First and last instance of a BER at the HRU; current condition, number of alarms
Span <i>n</i> LOSW, HDL1	First and last instance of LOSW on HDL1; current condition, number of alarms
Span <i>n</i> LOSW, HDL2	First and last instance of LOSW on HDL2; current condition, number of alarms
Span <i>n</i> Margin L1	First and last instance when margin dropped below the established threshold on Loop 1; current condition, number of alarms
Span <i>n</i> Margin L2	First and last instance when margin dropped below the established threshold on Loop 2; current condition, number of alarms
PWR-SHRT	Power short condition; current condition, number of alarms
PWR-GND	Power ground condition; current condition, number of alarms
Last Cleared:	Last time Alarm History cleared

### Alarm History Screen without Doubler

```

                                ALARM HISTORY

TIME: 00:27:54
DATE: 08/05/99
CIRCUIT ID#:

Type           First           Last           Current       Count
LOS, DS1-HLU           OK             000
LOS, DS1-HRU           OK             000
BER                   OK             000
SPAN1 LOSW, HDL1 02/01/99-00:00 02/01/99-00:00 OK             001
SPAN1 LOSW, HDL2 02/01/99-00:00 02/01/99-00:00 OK             001
SPAN1 MARGIN L1        OK             000
SPAN1 MARGIN L2        OK             000
PWR-SHRT              OK             000
PWR-GND                OK             000

LAST CLEARED: NONE

                                (E)xit (C)lear (U)pdate
    
```

*Figure 16. Alarm History Screen: No Doubler*

### Alarm History Screen for Doubler Applications

The Alarm History screen displays information by span. With no doubler, there is only one span (Figure 16). With multiple doublers (up to four), there can be as many as five span screens. Figure 17 is an example of an Alarm History screen that lists history for the fifth span (Doubler #4 to the HRU).

```

                                ALARM HISTORY

TIME: 13:59:20
DATE: 08/05/99
CIRCUIT ID#:

Type           First           Last           Current       Count
LOS, DS1-HLU           OK             000
LOS, DS1-HRU           OK             000
BER                   OK             000
SPAN5 LOSW, HDL1 02/01/99-00:00 02/01/99-00:00 OK             001
SPAN5 LOSW, HDL2 02/01/99-00:00 02/01/99-00:00 OK             001
SPAN5 MARGIN L1        OK             001
SPAN5 MARGIN L2        OK             001
PWR-SHRT              OK             000
PWR-GND                OK             000

LAST CLEARED: 03/04/99-13:49

                                (E)xit (C)lear (U)pdate (S)pan(1)(2)(3)(4)(5)
    
```

*Figure 17. Alarm History Screen: Four Doublers (Span 5)*

## View System Inventory Screen

The System Inventory screen (Figure 18 on page 36) lists the six possible units that can comprise one HiGain circuit: one HLU, one HRU and up to four doublers. The information in the System Inventory Screen is presented as follows:

- All six possible unit modules are always listed. The doublers are shown as: DB1, DB2, DB3, DB4.
- The model number, list number and software revision number of every unit that is present in the circuit is listed in the Product column. Units that are not detected are not considered to be present in the circuit and are labeled N/A. When the HLU-231 loses sync with Span 1, the product types are replaced by the N/A label until sync is reestablished and each module can in turn be reidentified.
- Each description in the Product column is limited to 24 alpha-numeric characters. To change a description, select its identifying letter. The descriptions, like the system settings, are stored in NVRAM and therefore remain when power is lost.
- The System Inventory screen displays HiGain unit serial numbers. For HLU-231 List 8A units manufactured prior to August 5, 1999, the screen displays only the last six digits of the serial number. Those HLUs manufactured after that date display all ten digits.
- The HLU requires no Unit ID description since it is usually identified by the Circuit ID.

Press **H** at the Maintenance Terminal Main Menu to display the System Inventory screen (Figure 18 and Figure 19 on page 36).

From each System Inventory screen (depending on the number of doublers), you can do the following:

- 1 Select the unit for which you want to set the circuit ID by pressing the letter that precedes the unit name.
- 2 Type the circuit ID, then press **ENTER**.

You can use up to 24 alphanumeric characters for the circuit ID. If more than 24 characters are entered, a warning beep is emitted and only the first 24 characters are accepted.

- 3 To set the circuit ID for another unit, repeat [Step 1](#) and [Step 2](#).
- 4 Press **E** to exit the System Inventory screen.

The system prompts you to confirm the circuit ID.

- 5 Press **C** to confirm the circuit ID and exit the System Inventory screen.



**Executing the default option from either the front panel or System Settings screen has no effect on the ID values.**

### System Inventory Screen without Doubler

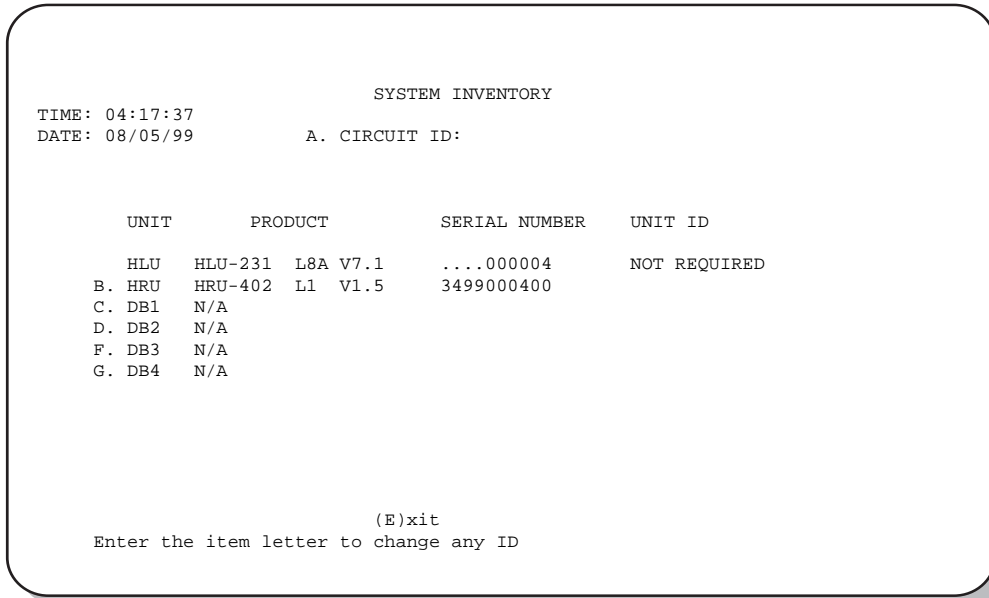

*Figure 18. System Inventory Screen: No Doubler*

### System Inventory Screen for Doubler Applications

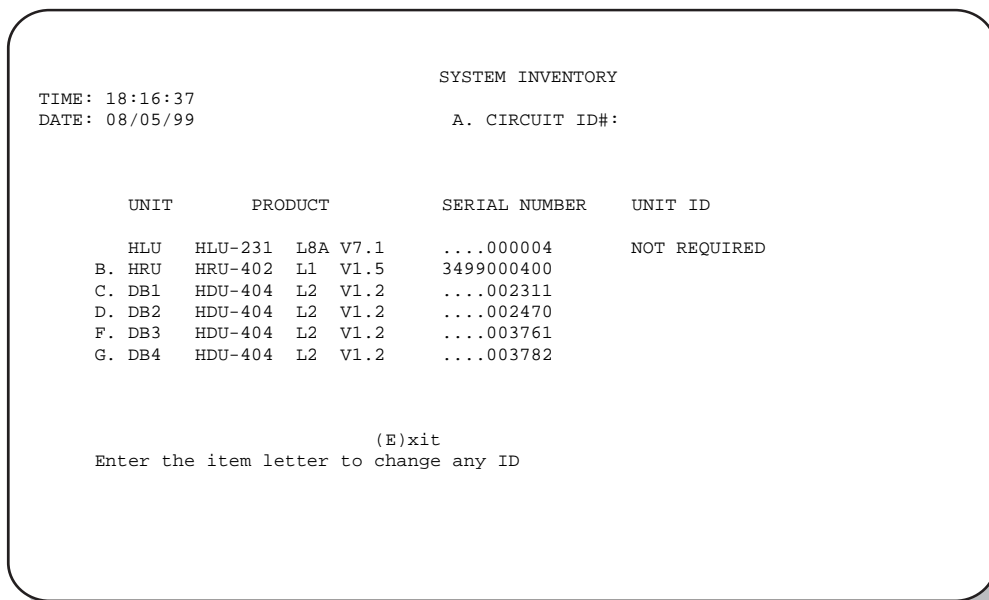

*Figure 19. System Inventory Screen: Four Doublers*

## View Troubleshooting Screen

The Troubleshooting screen graphically analyzes the circuit and identifies any problem areas.

Press **I** at the Maintenance Terminal Main Menu to access the Troubleshooting screen. The Troubleshooting screen (Figure 20) appears showing the HLU, the HRU and any doublers that are in the circuit (up to four).

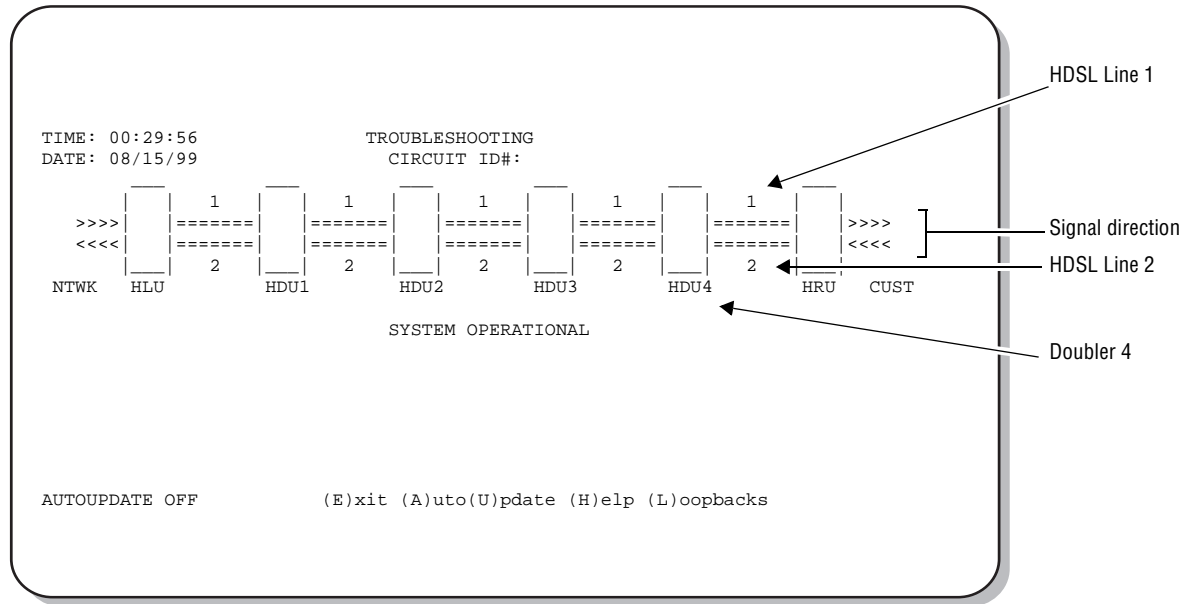

Figure 20. Troubleshooting Screen for a Doubler Application

Figure 21 shows an example of a circuit that has identifiable problems. Symbols on the troubleshooting diagram indicate the location of the circuit problems. The legend describes the type of problem.

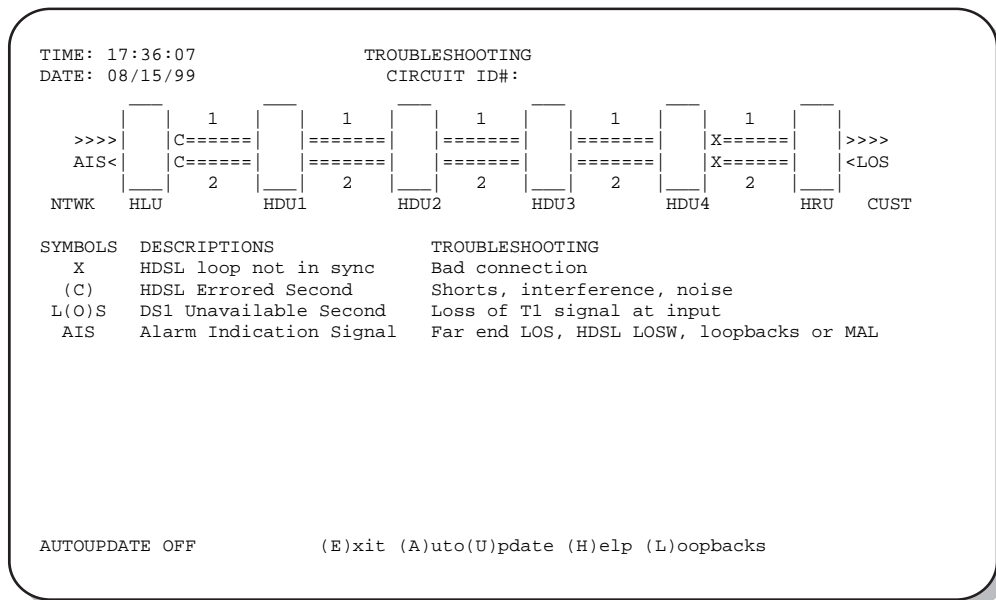

Figure 21. Troubleshooting Screen Describing Circuit Problem

To display the circuit Help diagram (Figure 22), press **H**. The symbol legend used to describe all circuit events and the corresponding troubleshooting tips are located beneath the Help diagram. A troubleshooting symbol on the diagram identifies the location of a problem.



**Legend symbols which appear in parentheses are also keyboard commands. Type the symbol in parentheses to access additional troubleshooting data.**

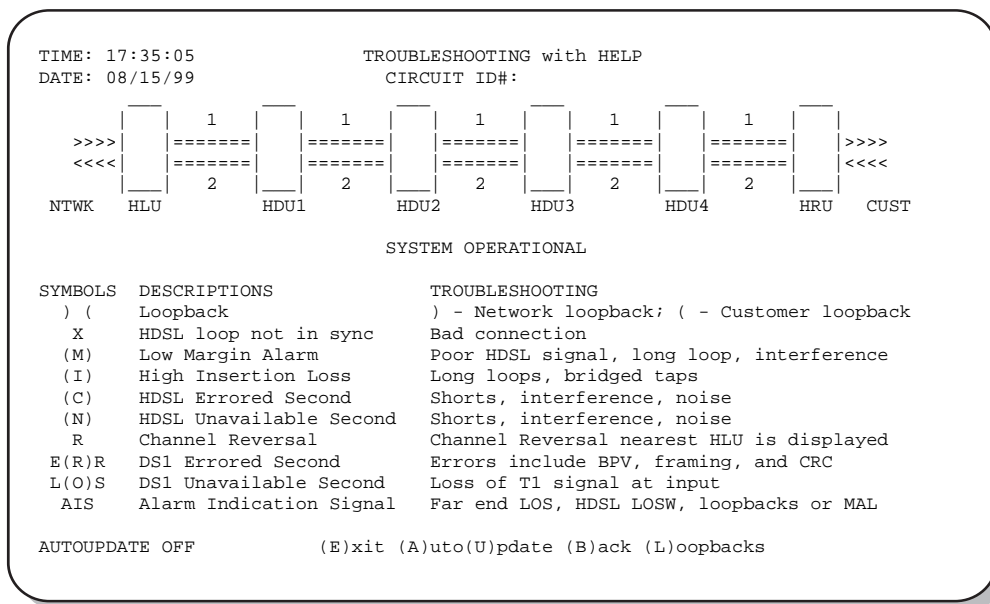

Figure 22. Troubleshooting with Help

- Press **M** to display margin values for the circuit (Figure 23 on page 39).
- Press **I** to display the insertion loss values for the circuit (Figure 24 on page 39).
- Press **C** to display the HDSL errored seconds screen.
- Press **N** to display the HDSL unavailable seconds screen.
- Press **R** to display the DS1 errored seconds screen.
- Press **O** to display the DS1 unavailable seconds screen.

The Troubleshooting screens use the following navigational keyboard commands:

- Press **E** to return to the Maintenance Terminal Main Menu.
- Press **B** to return to the main Troubleshooting screen from the Help, Margin Values or Insertion Loss screens.
- Press **U** to update a screen.
- Press **A** to automatically update the screen. (Press **A** again to deactivate auto update.) The Troubleshooting screen indicates whether AutoUpdate is on or off.
- Press **L** to directly access the Loopback menu (see “Loopback Mode Screen” on page 26).



**The first channel reversal (R) of the circuit closest to the line unit is indicated on the Troubleshooting screen. If another channel reversal exists, it will be identified as soon as the preceding channel reversal is corrected.**



Press **M** to display margin values for the circuit (Figure 23).

```

TIME: 17:34:38          TROUBLESHOOTING with MARGIN VALUES
DATE: 08/15/99          CIRCUIT ID#:

>>>> | 23 22 | 21 21 | 22 23 | 23 21 | 22 23 | >>>>
<<<< | ===== | ===== | ===== | ===== | ===== | <<<<
NTWK | 23 22 | 22 21 | 22 23 | 23 21 | 22 23 |
      HLU   HDU1  HDU2  HDU3  HDU4  HRU   CUST

                MARGIN

Margin is the signal-to-noise ratio at the HDSL transceiver.

An M symbol on the graph indicates a margin lower than 4 dB.

Low margin is a result of high noise level and/or low HDSL signal level.

Some causes of low margin:
- Long loop
- External interference
- Excessive cross-talk

AUTOUPDATE OFF          (E)xit (A)uto(U)pdate (B)ack (L)oopbacks

```

**Figure 23.** Troubleshooting with Margin Values

Press **I** to display the insertion loss values for the circuit (Figure 24).

```

TIME: 17:34:45          TROUBLESHOOTING with INSERTION LOSS VALUES
DATE: 08/15/99          CIRCUIT ID#:

>>>> | 01 01 | 00 01 | 00 00 | 00 00 | 00 01 | >>>>
<<<< | ===== | ===== | ===== | ===== | ===== | <<<<
NTWK | 01 00 | 00 01 | 00 00 | 00 00 | 00 00 |
      HLU   HDU1  HDU2  HDU3  HDU4  HRU   CUST

                INSERTION LOSS

Insertion loss is the attenuation of the HDSL signal at 196 kHz.
Pulse attenuation is directly related to insertion loss.

An I symbol on the graph indicates an insertion loss of 38 dB or higher.

High insertion loss is the result of a low received HDSL signal.

Some causes of high insertion loss:
- Long loop
- Bridged taps

AUTOUPDATE OFF          (E)xit (A)uto(U)pdate (B)ack (L)oopbacks

```

**Figure 24.** Troubleshooting with Insertion Loss Values

Press **C** to display the HDSL errored seconds, or press **R** to display DS1 errored seconds for the circuit (Figure 25).

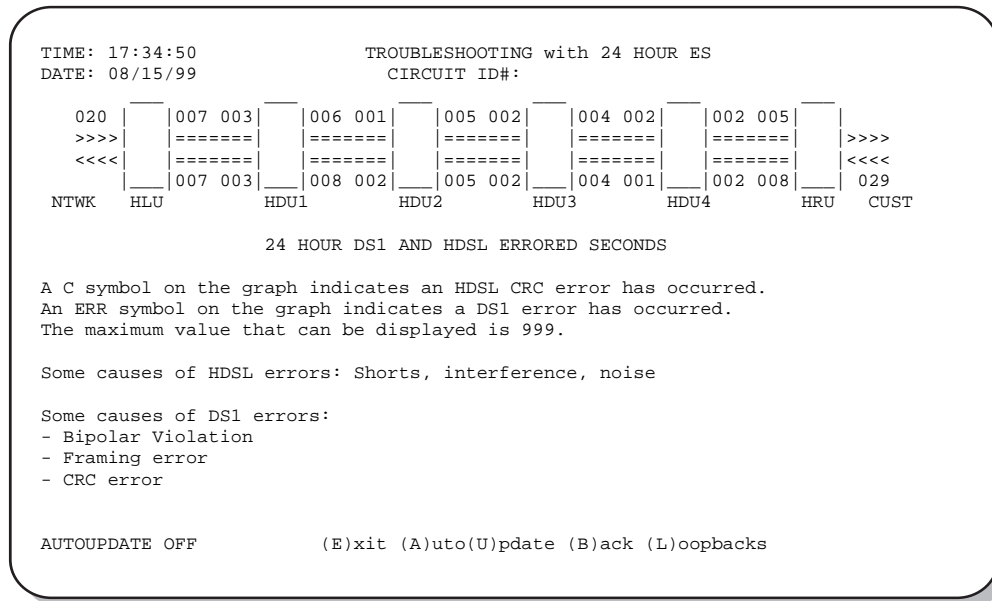

**Figure 25.** Troubleshooting with 24-Hour Errored Seconds (ES)

Press **N** to display HDSL unavailable seconds, or press **O** to display DS1 unavailable seconds for the circuit (Figure 26).

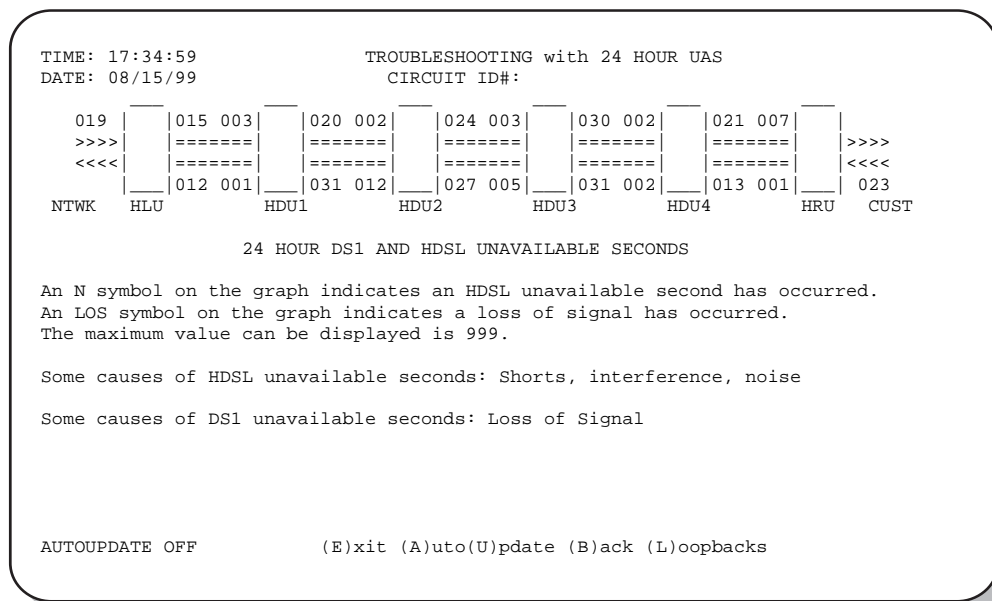

**Figure 26.** Troubleshooting with 24-Hour Unavailable Seconds (UAS)

# TROUBLESHOOTING

This section provides information about system alarms and loopback testing. In addition to these troubleshooting aids, the Maintenance Terminal provisioning interface includes troubleshooting screens that provide a basic graphical analysis of system problems (see “View Troubleshooting Screen” on page 37).

## SYSTEM ALARMS

Table 12 lists possible HLU-231 List 8A alarm states and the corresponding front-panel messages. More than one alarm condition can exist at any given time, but only one message can be displayed. For multiple alarms, only the highest priority alarm displays.

Table 12. HDSL System Alarms

Front-panel Message	Alarm State	Description	To Inhibit:
ALRM LOSW	Loss of Sync Word <sup>(a)</sup>	One of the HDSL loops has lost synchronization.	Cannot be inhibited.
ALRM LLOS	Local Loss of Signal	Loss of the DSX-1 input signal.	Cannot be inhibited.
ALRM RLOS	Remote Loss of Signal	Loss of the HRU DS1 input signal.	Disable the RDA (Remote DS1 Alarm) option. This prevents an LOS condition at the DS1 input to a HRU from closing the alarm contacts (pins 20 and 21 on the card-edge connector). The front-panel Status LED still flashes red and the ALRM RLOS message displays to alert you of the LOS state. LOS is sent towards the network from the HLU. This option prevents the common occurrences of a CPE LOS condition from generating recurring alarms and AIS payloads.
ALRM MAL1 or ALRM MAL2	Margin Alarm Loop1 or Margin Alarm Loop2	The margin on HDSL Loop 1 or Loop 2 has dropped below the minimum threshold value set by the terminal MARGIN ALARM THRES.	Set the Margin Alarm Threshold option to 0 (zero).
ALRM BER	Bit Error Rate exceeded	The combined T1 and HDSL BER has exceeded the set threshold limits of $10^{-6}$ or $10^{-7}$ .	Select NONE for the BER system option.
NONE	No alarm	No current alarm condition.	Cannot be inhibited.

(a) When both HDSL loops lose sync word (LOSW), a system alarm condition exists. However, since the HLU-231 enters a self test cycling mode, the front-panel LED lights yellow instead of red and the SELF TEST message displays instead of the ALRM message.

## Alarm Option for DLC Feed

To improve HiGain compatibility with the switch-to-protect features used in DLC feeder applications, the HLU-231 has an Alarm Pattern Option (ALMP) that allows you to select either an AIS or LOS T1 output payload for the following alarms:

- LOSW on any loop
- T1 LOS
- Margin alarm if HAIS = IL

## Retiring System Alarms

To retire a system alarm, press the SEL button and execute an Alarm Cut Off (ACO). An ACO turns the alarm off and replaces the ALRM message with an ACO message. The second part of the ALRM message, which defines the cause of the alarm, remains. Both parts of the message remain until the alarm condition clears or another higher priority alarm occurs.

## Self Test

The Self Test mode that occurs when both HDSL loops are not in sync has been enhanced to include the input DS1 transceiver chip. The Self Test procedure can cause the all ones pattern, that is normally transmitted from the HLU-231 during these out of sync intervals, to exhibit occasional BPVs.

## LOOPBACK OPERATION

HiGain has a family of loopback options for analyzing circuit functionality. The loopback signal is transmitted and returned to the sending device for comparison. This allows you to verify the integrity of the HDSL channels to the HLU, the HLU DSX-1 interface and the DS1 channels to the customer. Loopback options include:

- Generic Loopback (GNLB) options, including the SmartJack (SMJK) option (Table 13 on page 44)
- Special Loopback (SPLB) options (see “Special Loopback Commands” on page 45 and the following tables
  - Addressable Repeater Loopback commands: A1LB, A2LB, A5LB (Table 14 on page 49)
  - Addressable Repeater Loopback commands: A3LB, A4LB (Table 15 on page 52)

Loopback commands can be initiated by any of the following methods:

- selecting the loopback type using the MODE and SEL buttons on the HLU (or the Manual Loopback button on the HRU)
- selecting the loopback type from the Maintenance Terminal Main Menu when connected to the craft port of the HLU or HRU
- entering the loopback code into the test equipment connected to the HLU or HRU

### Generic Loopback Commands

The HiGain Generic Loopback (GNLB) commands allow you to use inband codes to loop up either NLOC (4-in-7) or NREM (3-in-7) towards the network. In addition, these inband codes loop up CREM (6-in-7) or CLOC (5-in-7) towards the customer. Either loop-up condition can be terminated (looped down) with the 3-in-5 SMJK loop-down code. All inband codes must be present for 5 seconds before the HiGain system responds. HiGain also supports  $NDU_n$  doubler loopbacks to the network and  $CDU_n$  doubler loopbacks towards the customer.

Figure 27 summarizes the available loopbacks in the system, and Table 13 on page 44 summarizes the HiGain generic loopback commands. See “GNLB Test Procedures” on page 47 for the test procedures that apply when using the GNLB mode.

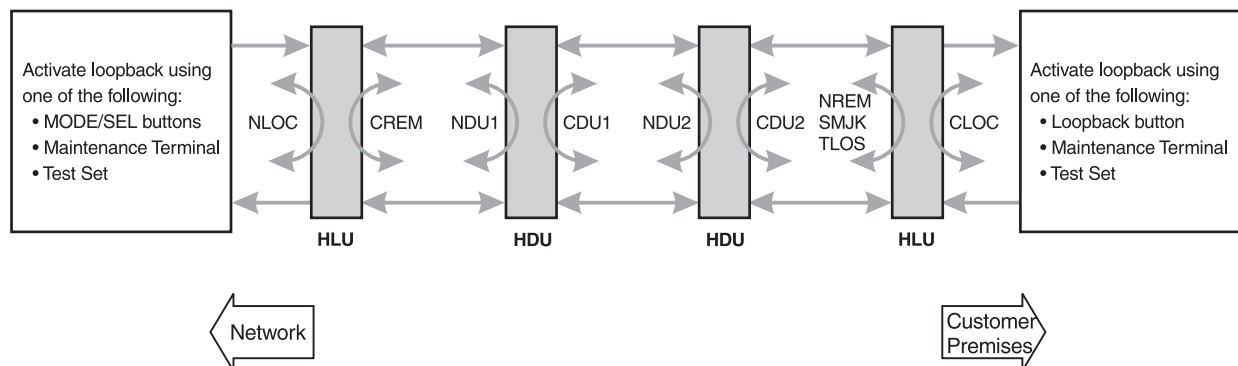

Figure 27. Loopback Summary



**If an LOSW occurs on a span between the remote and a doubler with a customer loopback (in a three-span or greater circuit), the loop may not come back up until the loopback is removed.**

**Table 13. Summary of HiGain Loopback Codes**

Loopback	Code	Description	Method of Transmission		
			Test Set	Craft Port	MODE/SEL
NLOC	1111000 4-in-7	Network Local. Invokes HLU loopback toward the network.	X	X	X
NDU1	110000 2-in-6	Network Doubler 1. Invokes HDU1 loopback toward the network.	X	X	X
NDU2	111000 3-in-6	Network Doubler 2. Invokes HDU2 loopback toward the network.	X	X	X
NDU3	1010001	Network Doubler 3. Invokes HDU3 loopback toward the network.	X	X	X
NDU4	1010010	Network Doubler 4. Invokes HDU4 loopback toward the network.	X	X	X
NREM	1110000 3-in-7	Network Remote. Invokes HRU loopback towards the network.	X	X	X
CLOC	1111100 5-in-7	Customer Local. Invokes HRU loopback towards the customer.	X	X	X
CDU1	111100 4-in-6	Customer Doubler 1. Invokes HDU1 loopback towards the customer.	X	X	X
CDU2	111110 5-in-6	Customer Doubler 2. Invokes HDU2 loopback towards the customer.	X	X	X
CDU3	1011001	Customer Doubler 3. Invokes HDU3 loopback towards the customer.	X	X	X
CDU4	1011010	Customer Doubler 4. Invokes HDU4 loopback towards the customer.	X	X	X
CREM	1111110 6-in-7	Customer Remote. Invokes HLU loopback towards the customer.	X	X	X
SMJK LpUp (PL)	11000 2-in-5	SmartJack Loopup or NID payload (PL) code. Invokes HRU loopback towards network.	X		
SMJK LpUp (ESF-DL)	1111-1111-0100-1000	SmartJack Loopup or NID (ESF-DL) code. Invokes HRU loopback towards network.	X		
SMJK LpDn (PL)	11100 3-in-5	SmartJack Loopdown or NID payload (PL) code. Removes SMJK, NLOC, NREM, CREM, CLOC, CDU $n$ , and NDU $n$ .	X		
SMJK LpDn (ESF-DL)	1111-1111-0010-0100	SmartJack Loopdown or NID (ESF-DL) code. Removes SMJK, NLOC, NREM, CREM, CLOC, CDU $n$ , and NDU $n$ .	X		



HiGain systems feature the SmartJack option, which can emulate a Network Interface Device (NID) for the purpose of loopback testing of the HiGain circuit. SMJK and NREM loopbacks perform the same functions but their initiation differs. SMJK indicates that the loopback was initiated by the 2-in-5 inband command. NREM, on the other hand, is initiated by the 3-in-7 inband command or by a command issued from the maintenance terminal or the MODE and SEL buttons.

Use the inband commands to enable or disable the SMJK loopback options. (Pressing the remote loopback button will also loopdown the SmartJack loopback.) The HLU system setting is normally enabled to recognize all inband SmartJack loopback commands.

## Special Loopback Commands

In addition to the GNLB loopback command mode, a HiGain system can be configured for one of five special loopback command modes. These are selected from the maintenance terminal System Settings screen (see [Table 8 on page 21](#)) or by using the MODE and SEL buttons (see [Figure 28 on page 48](#)). Once a loopback mode is activated, other loopback commands can be sent by a test set connected to the craft port of the HLU or HRU (see [Table 14 on page 49](#) and [Table 15 on page 52](#) for list of SPLB commands).

A1LB through A5LB are five special, addressable, repeater loopback modes which are supported by the HLU-231 List 8A. These loopback modes provide the HiGain system with sophisticated maintenance and troubleshooting tools. A1LB, A2LB, and A5LB are patterned after the Teltrend addressable T1 repeater loopbacks. A3LB and A4LB are patterned after the Wescom addressable T1 repeater loopbacks. All five SPLBs have been enhanced to handle the specific requirements of the following HiGain customers:

- A1LB (Teltrend) = Southwestern Bell
- A2LB (Teltrend) = Southwestern Bell
- A3LB (Wescom) = New England Telephone
- A4LB (Wescom Mod 1) = New York Telephone
- A5LB (Teltrend Mod 1) = Southern New England Telephone (SNET), Southwestern Bell, Pacific Bell

The A1LB loopback selection complies with that proposed for HDSL systems in the T1E1.4/92 recommendation with the following additions:

- query loopback
- IOR (Intelligent Office Repeater) power-down
- four loopback time-out choices
- initiation from either end
- repeating bit error signatures
- alternate query loopback

These additions make A1LB identical to A2LB. A1LB is given a separate identity to allow future T1/E1 enhancements to be added without affecting A2LB.

A5LB differs from A2LB in that A5LB does not block the arming code from exiting the HLU-231 into the network. A2LB can be configured to do one of the following:

- block the arming code (after 2 seconds) from exiting the HLU into the network, and replace it with the AIS code.
- unblock the AIS code by executing the Far-End Activate code. (Since A5LB never blocks the arming code from exiting the HLU, the Far-End Activate code is not available in A5LB.)

A3LB differs from A4LB in that A3LB supports the additional (1-in-6) SMJK loopback command.



**A HiGain system may take longer than normal to respond to inband loopback commands when its framing mode is set to UNFR and the inband commands are set in either SF or ESF mode. The frame bits override the command bits and cause errors in the command sequence. These errors cause the HiGain system to reject some sequences.**

## Initiating a Manual Loopback Session

A manual loopback session allows you to select any one of the HiGain GNLB loopbacks listed in [Table 13 on page 44](#) with the exception of SmartJack loopbacks, which can only be issued by inband commands.

### Setting the Loopback Time-out Option

Before initiating a loopback session, verify that the Loopback Time-out parameter is set to the desired setting.

- 1 Use the MODE and SEL buttons as described in “[Setting Options through MODE and SEL](#)” on page 11.  
(The Loopback Time-out parameter is also user-selectable from the System Settings screen when using a maintenance terminal.)
- 2 Enter the desired setting:
  - NONE (no time-out)
  - 20 minutes
  - 60 minutes (default setting)
  - 120 minutes

## Initiating a Manual Loopback Session



**With the exception of SmartJack, any of the HiGain loopbacks can be executed using the MODE and SEL buttons.**

**When executing a manual loopback session using the MODE and SEL buttons:**

- **The next loopback option can be presented by pressing the MODE button, however, the previously activated loopback remains active until the SEL button is pressed, which activates the new loopback.**
- **If neither button is pressed for a period of 30 seconds and no loopback is in effect, the manual loopback session terminates and the display returns to normal mode.**
- **If any loopback is in effect, the 30-second time-out is inhibited. The active loopback and the manual loopback session continue until the loopback times out in accordance with the LBTO setting.**
- **Only the SMJK loopback can exist with another network loopback at any given time. In general, it is preferable to have only one active loopback.**
- **If there is an active loopback, pressing the MODE and SEL buttons for 3 or more seconds terminates any active loopback, ends the manual loopback session and returns the display to normal mode.**

To initiate a manual loopback session:

- 1 Press both the MODE and SEL buttons on the front panel for at least 3 seconds. The following message appears on the front-panel display:  
MAN LPBK NLO?
- 2 Press SEL to activate NLOC.
- 3 The following message appears: Perform selected loopback (Y or N)?
- 4 Type Y. The display changes to MAN LPBK NLOC.
- 5 Press MODE to advance to the next available loopback (ND1? ND2? ND3? ND4? NRE? CRE? CD1? CD2? CD3? CD4? CLO?).
- 6 Press SEL to activate the selected loopback. The previous loopback is terminated.



Once a loopback is selected and activated, the loopback stays active until it times out (based on the LBTO setting). When a loopback times out, the display then returns to the normal display mode.

You can terminate loopbacks manually and exit the MAN LPBK mode by simultaneously pressing the MODE and SEL buttons for 3 or more seconds. If no loopback is active, the MAN LPBK mode automatically terminates after 30 seconds.

All loopbacks can be initiated by inband commands in the T1 payload or by a command from the HiGain system (front-panel buttons or maintenance screen selections). Therefore, whenever a loopback is active, the method by which it was activated is indicated in the Loopback and Status screens by the annotation HG (HiGain) or PL (Payload) adjacent to the identified loopback. For example, NREM (HG) indicates that the loopback was initiated by the HiGain system.



**SMJK loopback commands are only activated by inband commands.**

## LOOPBACK TEST PROCEDURES

The following sections provide step-by-step test procedures for verifying the integrity of the HDSL channels at every module location as well as the DS1 channels to the customer and the local DSX-1 interface.

### General Troubleshooting Tips

If trouble is encountered on the DSX-1 interface of the HLU-231, verify that the:

- HLU is making a positive connection with its mounting assembly (shelf) connector.
- HLU internal equalizer is set to the correct distance range per [Table 8 on page 21](#). All equalizers should be set to the distance from the DSX-1 to the shelf.

The transmit and receive T1 DSX-1 ports have splitting access jacks and miniature, 210-series, monitoring jacks as shown in [Figure 1 on page 4](#). Connecting one cable between the two monitoring jacks and another between the two SPAN jacks splits the XMT and RCV and creates metallic loopbacks towards both the DSX-1 and the HLU-231. If separate plugs are inserted into both SPAN jacks with the other end disconnected, the MON jacks can be used to send and receive test patterns towards the DSX-1.

### GNLB Test Procedures

[Figure 28 on page 48](#) is a graphical representation of the various generic loopback configurations with the associated GNLB commands shown. Also, refer to [Table 13 on page 44](#) for a description of these commands.

To perform the GNLB loopback test procedure:

- 1 Have the CO tester send the NREM (3-in-7) inband loopup code for 5 seconds. You should be able to observe the NREM message on the front-panel display. (The Status LED on the front panel should be green, and the loopback mode should also be identified on the Span Status screen.)
- 2 Have the CO tester transmit a T1 test signal towards the HLU-231 and verify that the returned (looped) signal to the test set is error-free.
- 3 If step 2 fails, have the CO tester transmit the (3-in-5) inband loopdown code.
- 4 Have the CO tester send the NLOC (4-in-7) inband loopup for 5 seconds. You should be able to observe the NLOC message on the front-panel display. (The Status LED on the front panel should be yellow, and the loopback mode should also be identified on the Span Status screen.)

- Repeat Step 2. If the test passes, the problem is in the downstream direction. If it fails, the problem is in the upstream direction.

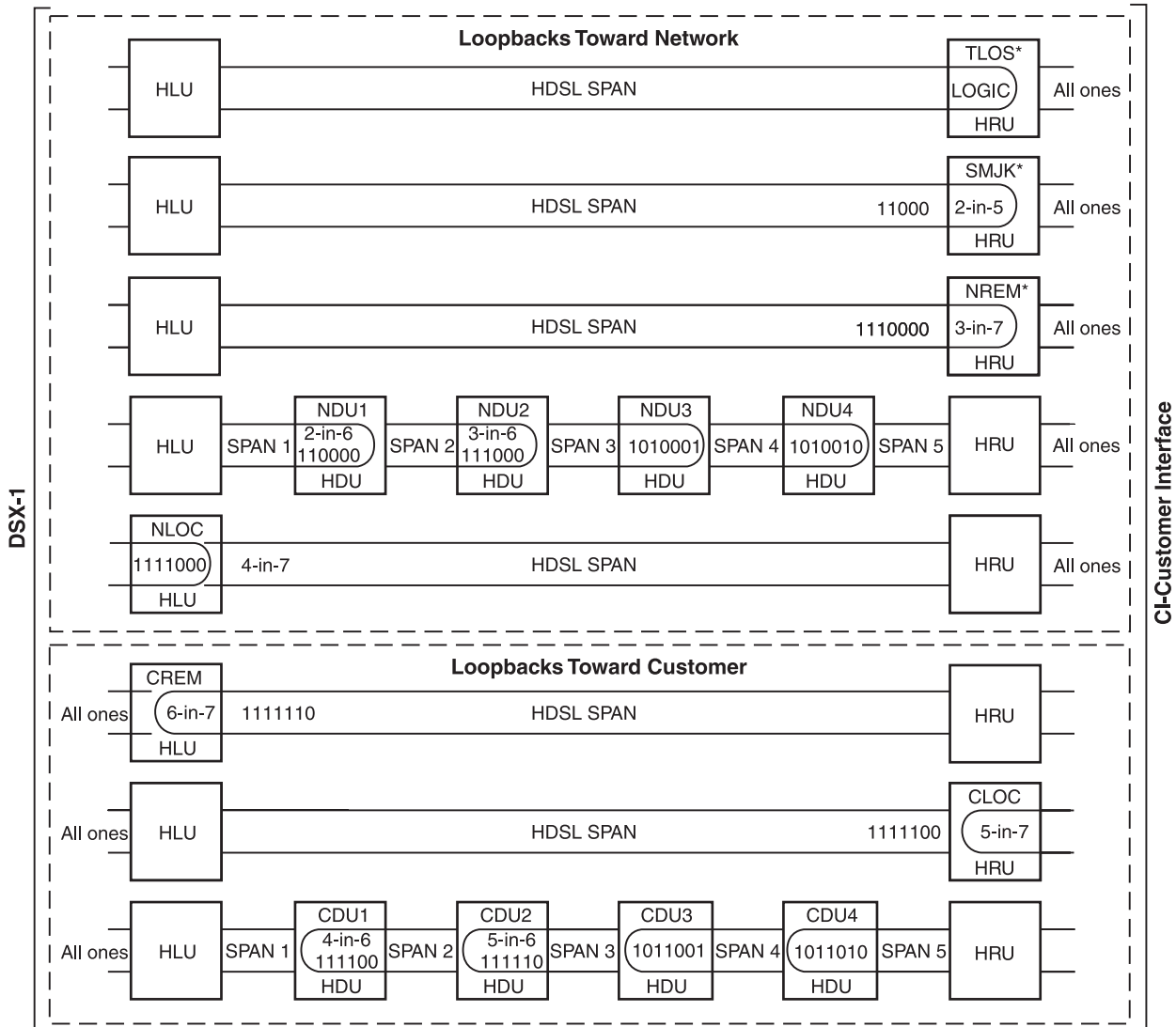

\* Set the SAIS option to ENA to send AIS (indicated by an all ones pattern) to the CI during SmartJack loopback, NREM, and TLOS. Use the 3-in-5 code to loop down.

Figure 28. Loopback Configurations



Pressing the Loopback button on a remote unit will deactivate the SmartJack loopback.

## A1LB, A2LB, and A5LB Test Procedures

Using the codes listed in [Table 14](#), a network tester can activate NLOC or NREM loopbacks (or SMJK, if enabled). A tester at the customer premises can activate CLOC or CREM loopbacks. All loopbacks shown in [Table 14](#) can also be initiated from the HLU-231 front-panel MODE and SEL buttons (see “[Setting Options through MODE and SEL](#)” on page 11). Information specific to HiGain doublers is shown in bold type.

**Table 14.** Addressable Repeater Loopback Commands (A1LB, A2LB, A5LB)

Name	Description	Binary Code <sup>(a)</sup> (Hexadecimal Equivalent)
ARMING or NI LPBK (inband)	Arming code	11000-11000 ...
ARMING or NI LPBK (ESF Data Link)	Arming code	1111-1111-0100-1000 (FF48)
IR LPDN or DISARM (inband)	Disarming code	11100-11100 ...
IR LPDN or DISARM (ESF Data Link)	Disarming code	1111-1111-0010-0100 (FF24)
IOR LPBK (NLOC and CREM 230-232 bit errors and 229-231 bit errors) <sup>(b)</sup>	HLU loopup	1101-0011-1101-0011 (D3D3)
ILR-1 LPBK (NDU1 and CDU1 10 bit errors) <sup>(b)</sup>	<b>HDU1 loopup</b>	<b>1100-0111-0100-0001 (C741)</b>
<b>LR-20 LPBK (NDU2 and CDU2 200 bit errors)</b>	<b>HDU2 loopup</b>	<b>1100-0111-0101-0100 (C754)</b>
<b>ILR-3 LPBK (NDU3 and CDU3 30 bit errors)</b>	<b>HDU3 loopup</b>	<b>1100-0111-0100-0011 (C743)</b>
<b>ILR-4 LPBK (NDU4 and CDU4 40 bit errors)</b>	<b>HDU4 loopup</b>	<b>1100-0111-0100-0100 (C744)</b>
<b>ILR-2 LPBK (NREM and CLOC 20 bit errors)</b>	<b>HRU loopup</b>	<b>1100-0111-0100-0010 (C742)</b>
IR LPDN	Loopdown (HLU, HDU, or HRU)	1001-0011-1001-0011 (9393)
IR QUERY LPBK	Query loopback	1101-0101-1101-0101 (D5D5)
IR ALTERNATE QUERY LPBK	Alternate query loopback	1101-0101-1110-1010 (D5EA)
TIME-OUT OVERRIDE	Loopback time-out override	1101-0101-1101-0110 (D5D6)
FAR END NI ACTIVATE <sup>(c)</sup>	Unblock AIS	1100-0101-0101-0100 (C554)
IOR POWER DOWN (HLU) <sup>(d)</sup>	Removes HDSL line power	0110-0111-0110-0111 (6767)

(a) The left most bit arrives first in all sequences. The detection algorithm functions reliably with a random  $10^{-3}$  Bit Error Ratio (BER) on the facility. The entire arming and loopback sequence can also be initiated at the remote HRU location.

(b) The HRU identifies CREM (and the HLU identifies NLOC) with 231 bit errors, including the frame bits. When framed data is being sent in the AUTO framing mode, the number of the 231 bit errors detected by the test set varies from 229 to 231, depending on whether or not the test set counts frame errors as bit errors, and on the number of frame bits contained in the block of 231 error bits. The HRU and HLU generate this bit pattern in a series of discontinuous bursts containing 20-bit errors each, including frame bits. Those test sets that do not count frame error bits as data bit errors will indicate fewer bits than the HRU and HLU transmit for a CI and NI loopback.

(c) Sending the Far-End NI Activate code is not required in A5LB because it is always activated.

(d) The IOR Power Down code must remain present for the duration of the power down mode. When this code is removed, the HiGain system returns to its normal unlooped and unarmed state.

To perform the A1LB, A2LB, and the A5LB test procedures:

- 1 Send the inband Arming and NI LPBK code 11000 to the HLU-231 for at least 5 seconds.
- 2 Monitor the output of the HLU-231 for the return of the pattern. Return of the pattern indicates one of the following:
  - the HRU has looped up (if the SMJK Loopback option is Enabled)
  - an external NI has looped up (if the SMJK Loopback option is Disabled), and the HLU and HRU have been armed
- 3 Verify, if possible, that the HRU Loopback LED is either flashing yellow at 4-second intervals (indicating that the system is armed), or is a steady green (indicating that it is both armed and in SMJK loopback). The HLU Status LED also flashes yellow when the system is armed.
- 4 Once armed, the HLU-231 can be looped back by sending Intelligent Office Repeater (IOR) LPBK activation code 1101-0011-1101-0011 (D3D3) for at least 5 seconds. You should observe the following activation response pattern in the order presented:
  - a 2 seconds of AIS (identified by an all ones pattern)
  - b 2 seconds of returning data pattern
  - c 231 logic errors (including the frame bit) occurring in the returned pattern comprising:
    - 10 errors, if ILR-1 (Doubler 1) was sent
    - 200 errors, if ILR-20 (Doubler 2) was sent
    - 30 errors, if ILR-3 (Doubler 3) was sent
    - 40 errors, if ILR-4 (Doubler 4) was sent
    - 20 errors, if ILR-2 (HRU) was sent
  - d normal looped data

This error pattern repeats every 20 seconds as long as the IOR loopback pattern is being sent. This also applies to ILR, Time-out Override, and Query commands.



**Some Intelligent Repeater (IR) test sets do not count frame errors as bit errors when the test pattern is framed and the HLU-231 is set to the Auto framing mode. To improve compatibility with those test sets, the HLU-231 generates 201 (NDU2 and CDU2) and 232 (NLOC and CREM) ID bit errors. As a result, the HLU-231 may indicate one more or one less bit error, depending on the test set type and the number of frame bits contained in the block of errored bits. To avoid this uncertainty, PairGain recommends sending unframed IR commands.**

The HLU is now in logic loopback if the IOR NLOC loopback command was sent. The Time-out Override command or a Loopdown command can override the selection made for the loopback time-out (see [“Setting the Loopback Time-out Option”](#) on page 46). If the Time-out Override code 1101-0101-1101-0110 (D5D6) is received after activating a loopback, then the automatic timed expiration of the loopback is inhibited. If this Time-out Override is sent, then the only way to loop the HLU-231 down is to do one of the following:

- issue the IR LPDN (loopdown) code 1001-0011-1001-0011 (9393)
- issue the NI LPDN and Disarm inband code 11100 or the ESF-DL code (FF24).



**The Time-out Override function is only valid for the current active loopback. The automatic time-out timer is restored during subsequent loopback sessions.**

- 5 Once the test is complete, do one of the following:
- If the system is to loopdown but remain Armed, send the IR LPDN code (universal loopdown).
  - If all the equipment is to be looped down, disarmed and returned to normal operation, send the disarm inband code 11100 or the ESF-DL code (FF24).



**The Armed mode has an automatic time-out of 120 minutes but this timer is reset to 120 for any of the following events:**

- **Loopback terminates (manually or time-out),**
- **Query**
- **Alternate query**
- **Far end activate**
- **Another ARM command.**

**This timer is inhibited while any of the valid command codes are being sent. Once the codes are removed, the timer restarts at 120.**

### A3LB and A4LB Test Procedures

The HLU-231 can be looped back by sending the Addressable Office Repeater (AOR) LPBK activation code 1111-1111-0001-1110 (FF1E) for at least 5 seconds. This causes the HLU-231 to enter the NLOC state. The Loopback Time-out setting (see “Setting the Loopback Time-out Option” on page 46) determines the duration of this loopback unless it is overridden by the reception of a second identical 16-bit loop-up command before the timer expires. When this time-out override state exists, the only way to loop the HLU-231 down is to issue one of the three loopdown commands listed in Table 15. The automatic time-out mode is restored during subsequent loopback sessions.

Table 15 summarizes the codes required to execute Addressable 3 and 4 (A3LB and A4LB) repeater loopback commands. All code sequences must be present for at least 5 seconds. Information specific to HiGain doublers is shown in bold.

**Table 15. Addressable Repeater Loopback Commands (A3LB and A4LB)**

Name	Description	Binary Code <sup>(a)</sup> (Hexadecimal Equivalent)
NLOC	HLU-231 line unit from NI	1111-1111-0001-1110 (FF1E)
CREM	HLU-231 line unit from CI	0011-1111-0001-1110 (3F1E)
<b>NDU1</b>	<b>HDU doubler 1 from NI</b>	<b>1111-1111-0000-0100 (FF04)</b>
<b>CDU1</b>	<b>HDU doubler 1 from CI</b>	<b>0011-1111-0000-0100 (3F04)</b>
<b>NDU2</b>	<b>HDU doubler 2 from NI</b>	<b>1111-1111-0000-0110 (FF06)</b>
<b>CDU2</b>	<b>HDU doubler 2 from CI</b>	<b>0011-1111-0000-0110 (3F06)</b>
<b>NDU3</b>	<b>HDU doubler 3 from NI</b>	<b>1111-1111-0000-1000 (FF08)</b>
<b>CDU3</b>	<b>HDU doubler 3 from CI</b>	<b>0011-1111-0000-1000 (3F08)</b>
<b>NDU4</b>	<b>HDU doubler 4 from NI</b>	<b>1111-1111-0000-1010 (FF0A)</b>
<b>CDU4</b>	<b>HDU doubler 4 from CI</b>	<b>0011-1111-0000-1010 (3F0A)</b>
NREM	HRU loopup from NI	1111-1111-0000-0010 (FF02)
CLOC	HRU loopup from CI	0011-1111-0000-0010 (3F02)
SMJK	HRU loopup from NI	11000-11000-11000 ...
SMJK	HRU loopup from NI <sup>(b)</sup>	100000 100000 100000 ...
SMJK	HRU loopup from NI (ESF-DL)	1111-1111-0100-1000 (FF48)
Loopdown	HLU and HRU loopdown from NI OR CI	11100-11100-11100 ...
Loopdown	HLU and HRU loopdown from NI OR CI	100-100-100 ...
Loopdown	HLU and HRU loopdown from NI OR CI (ESF-DL)	1111-1111-0010-0100 (FF24)

(a) The left-most bit arrives first in all sequences. The detection algorithm functions reliably with a random 10<sup>-3</sup> Bit Error Ratio (BER) on the facility. The entire arming and loopback sequence can also be initiated at the remote HRU location.

(b) Not supported by A4LB.

# APPENDIX A - SPECIFICATIONS

This appendix provides general specifications, pinout diagrams for the craft port and card-edge connector, HDSL insertion loss guidelines, and power consumption and dissipation tables.

<b>HDSL Line Code</b>	784 kbps 2B1Q
<b>HDSL Output</b>	+13.5 dBm $\pm$ 0.5 dB at 135 $\Omega$
<b>HDSL Line Impedance</b>	135 $\Omega$
<b>Maximum Provisioning Loss</b>	35 dB at 196 kHz, 135 $\Omega$
<b>HDSL Start-up Time</b>	30 sec. (typical), 60 sec. (maximum) per span
<b>One-way DS1 Delay</b>	<200 $\mu$ s per span without doublers. Doubler delay <80 $\mu$ s
<b>DSX-1 Line Impedance</b>	100 $\Omega$
<b>DSX-1 Pulse Output</b>	6 V <sup>pk-pk</sup> , pre-equalized for 0-655 feet of ABAM cable
<b>DSX-1 Input Level</b>	+1.5 to -7.5 dBDSX
<b>DS1 Line Rate</b>	1.544 Mbps $\pm$ 200 bps
<b>DS1 Line Format</b>	AMI, B8ZS or ZBTISI
<b>DS1 Frame Format</b>	ESF, SF or UNFR
<b>Maximum Heat Dissipation</b>	See <a href="#">“Power Consumption” on page 54</a>
<b>Fusing</b>	Internal; connected to Fuse Alarm output on pin 32
<b>HDSL Span Voltage</b>	0, -140 or $\pm$ 112 Vdc
<b>Electrical Protection</b>	Secondary surge and power cross protection on HDSL ports. Requires external primary protection
<b>Operating Temperature</b>	-40 °F to +149 °F (-40 °C to +65 °C)
<b>Operating Humidity</b>	5% to 95% (non-condensing)
<b>Mounting</b>	220 mechanics
<b>Dimensions</b>	
Height:	5.9 in. (15 cm)
Width:	1.4 in. (3.5 cm)
Depth:	10 in. (25.4 cm)
Weight:	8 oz. (.23 kg)
<b>Wander (Looped)</b>	0.3 UI maximum (1 UI = 648 ns)
<b>WB Jitter (Looped)</b>	0.2 UI maximum
<b>NB Jitter (Looped)</b>	0.1 UI maximum

## HDSL INSERTION LOSS GUIDELINES

Each loop has no more than 35 dB of loss at 196 kHz, with driving and terminating impedances of 135  $\Omega$ . Table 16 provides a “loss” guide for the various cable gauges at 196 kHz and 135  $\Omega$ . The table applies to the HDSL cable pairs between the HLU, HRU, and HDU modules. In the absence of specific insertion loss measurement data, add 3 dB for each bridged tap and 1 dB for each cable gauge change.

**Table 16.** HDSL Loss Over Cables

Cable Gauge	Loop Loss <sup>(a)</sup> (dB per kft)	Loop Resistance ( $\Omega$ per kft)
26 AWG / 0.4 mm	3.88	83
24 AWG / 0.51 mm	2.84	52
22 AWG / 0.61 mm	2.18	32
19 AWG / 0.91 mm	1.54	16

(a) At 196 kHz, 68°F (20°C)



A Windows-based program, **Cable Calculator**, may be downloaded from the Customer site portion of the PairGain web site at [www.pairgain.com](http://www.pairgain.com). If you don't have a customer password, contact your sales representative.

## POWER CONSUMPTION

Power consumption and heat dissipation depends upon the type of remote and doubler units in the system and the CPE power setting.

### Power Consumption without Doublers

The three most important power parameters of an HLU are its maximum power consumption, its maximum power dissipation and its maximum current drain.

Table 17 describes line-powered circuits on 9 kft, 26 AWG loops without a doubler.

**Table 17.** Power Parameters—No Doubler

HRU Model No.	HRU CPE Power	42.5 Vdc Power Consumption (Watts)		Heat Dissipation (Watts)		42.5 Vdc Current (mA)	
		Typical	Maximum	Typical	Maximum	Typical	Maximum
HRU-412 List 1, 2, 3, 4	ON	12.0	13.2	5.1	5.6	284	312
HRU-412 List 1, 2, 3, 4	OFF	11.0	12.1	5.0	5.5	260	286
HRU-412 List 6, 7, 8	ON	12.6	13.9	5.2	5.7	297	327
HRU-412 List 6, 7, 8	OFF	9.7	10.7	4.5	4.9	228	251
HRU-402	N/A	7.7	8.5	4.5	4.9	182	200
HRU-411 <sup>(a)</sup>	ON	21.0	23.1	6.3	6.9	495	544
HRU-411	OFF	8.2	9.0	5.2	5.7	193	212

(a) HLU-231 PWRP option set to HIGH.



## Power Consumption with Doublers

Table 18 through Table 24 list the power consumed and dissipated by the HLU-231 when it is used with any of the four basic doubler types in the HiGain family. The maximum current drawn by the CO supply is also listed.

Table 18 through Table 20 shows power parameters for single doubler, line-powered circuits on 9 kft, 26 AWG loops.

**Table 18.** Power Parameters—Single Doubler (HDU-451 List 1 or 2)

HRU Model No.	HRU CPE Power	42.5 Vdc Power Consumption (Watts)		Heat Dissipation (Watts)		42.5 Vdc Current (mA)	
		Typical	Maximum	Typical	Maximum	Typical	Maximum
HRU-412 List 1, 2, 3, 4	ON	27.5	30.3	7.6	8.4	646	711
HRU-412 List 1, 2, 3, 4	OFF	25.9	28.5	7.2	7.9	610	671
HRU-412 List 6, 7, 8	ON	27.7	30.5	7.6	8.4	651	716
HRU-412 List 6, 7, 8	OFF	24.3	26.7	7.1	7.8	571	628
HRU-402	N/A (OFF)	21	23.1	6.3	6.9	494	543
HRU-411	OFF	20	22.0	6.2	6.8	471	518

**Table 19.** Power Parameters—Single Doubler (HDU-439 or HDU-437 Lists 1 and 1B)

HRU Model No.	HRU CPE Power	42.5 Vdc Power Consumption (Watts)		Heat Dissipation (Watts)		42.5 Vdc Current (mA)	
		Typical	Maximum	Typical	Maximum	Typical	Maximum
HRU-412 List 1, 2, 3, 4	ON	22.3	24.5	7.9	8.6	525	578
HRU-412 List 1, 2, 3, 4	OFF	21.4	23.5	7.8	8.5	502	552
HRU-412 List 6, 7, 8	ON	22.3	24.5	8.0	8.8	524	576
HRU-412 List 6, 7, 8	OFF	19.2	21.1	7.3	8.1	452	497
HRU-402	N/A (OFF)	16.0	17.6	6.7	7.4	376	414
HRU-411	OFF	15.6	17.2	6.7	7.4	367	404

**Table 20.** Power Parameters—Single Doubler (HDU-404 List 2, HDU-407 List 2, and HDU-409 List 2)

HRU Model No.	HRU CPE Power	42.5 Vdc Power Consumption (Watts)		Heat Dissipation (Watts)		42.5 Vdc Current (mA)	
		Typical	Maximum	Typical	Maximum	Typical	Maximum
HRU-412 List 1, 2, 3, 4	ON	18.8	20.7	7.0	7.7	442	486
HRU-412 List 1, 2, 3, 4	OFF	18.0	19.8	7.1	7.8	424	466
HRU-412 List 6, 7, 8	ON	18.4	20.2	6.9	7.6	433	476
HRU-412 List 6, 7, 8	OFF	15.7	17.3	6.8	7.4	370	407
HRU-402	N/A (OFF)	12.5	13.8	5.9	6.5	294	323
HRU-411	OFF	12.0	13.2	5.8	6.4	283	311

Table 21 through Table 23 show power parameters for two doubler, line-powered circuits on 9 kft, 26 AWG loops.

**Table 21.** Power Parameters—Two Doublers (HDU-451 List 3, 4, 3B or 4B)

HRU Model No.	HRU CPE Power	42.5 Vdc Power Consumption (Watts)		Heat Dissipation (Watts)		42.5 Vdc Current (mA)	
		Typical	Maximum	Typical	Maximum	Typical	Maximum
HRU-402	N/A (OFF)	28.3	31.1	8.3	9.1	665	732
HRU-411	OFF	28.1	30.9	8.2	9.0	661	727

**Table 22.** Power Parameters—Two Doublers (HDU-439 or HDU-437 Lists 1 and 1B)

HRU Model No.	HRU CPE Power	42.5 Vdc Power Consumption (Watts)		Heat Dissipation (Watts)		42.5 Vdc Current (mA)	
		Typical	Maximum	Typical	Maximum	Typical	Maximum
HRU-412 List 1, 2, 3, 4	OFF	30.3	33.3	8.0	8.8	713	784
HRU-412 List 6, 7, 8	OFF	28.1	30.9	7.7	8.5	660	726
HRU-402	N/A (OFF)	24.8	27.3	7.2	7.9	584	642
HRU-411	OFF	27.7	30.5	7.5	8.3	652	717

**Table 23.** Power Parameters—Two Doublers (HDU-404 List 2, HDU-407 List 2, and HDU-409 List 2)

HRU Model No.	HRU CPE Power	42.5 Vdc Power Consumption (Watts)		Heat Dissipation (Watts)		42.5 Vdc Current (mA)	
		Typical	Maximum	Typical	Maximum	Typical	Maximum
HRU-412 List 1, 2, 3, 4	ON	24.4	26.8	7.2	7.9	575	633
HRU-412 List 1, 2, 3, 4	OFF	22.1	24.3	6.8	7.5	520	572
HRU-412 List 6, 7, 8	ON	25.9	28.5	7.4	8.1	609	670
HRU-412 List 6, 7, 8	OFF	20.2	22.2	6.4	7.0	476	524
HRU-402	N/A (OFF)	17.4	19.1	7.1	7.8	410	451
HRU-411	OFF	16.5	18.2	6.0	6.6	389	428

Table 24 shows power parameters for three doubler, line-powered circuits or four doubler, locally-powered circuits on 9 kft, 26 AWG loops.

**Table 24.** Power Parameters—Three and Four Doublers (HDU-404 List 2, HDU-407 List 2, and HDU-409 List 2)

HRU Model No.	HRU CPE Power	42.5 Vdc Power Consumption (Watts)		Heat Dissipation (Watts)		42.5 Vdc Current (mA)	
		Typical	Maximum	Typical	Maximum	Typical	Maximum
HRU-402, 3-doubler, line-powered	N/A (OFF)	22.9	25.2	8.1	8.9	539	593
HRU-402, 4-doubler, local power	N/A (OFF)	23.7	26.1	8.0	8.8	557	613

## MAXIMUM POWER DISSIPATION

The Maximum Power Dissipation measures the power that is converted into heat that builds up within the unit. It contributes to the total heat generated in the space around the unit. It is used to determine the maximum number of fully loaded shelves per bay that does not exceed the maximum allowable power dissipation density in watts per square foot to comply with GR-63.

In COs, the maximum power dissipation for open-faced, natural convection-cooled mountings is limited to 134.7 watts per square foot per GR-63-CORE. The footprint of a standard 14-slot, 23-inch HCS-417 shelf in a narrow aisle is 7.024 square feet. Therefore, the maximum bay dissipation is limited to 946 watts. Use this limit and the parameters in [Table 17](#) through [Table 24](#) to determine the maximum number of HLU circuits that can occupy one CO bay.



**This is a worst case situation since it assumes the entire CO is subjected to the maximum power density. More favorable conditions would permit increasing the number of shelves per bay without jeopardizing the CO thermal integrity.**

The thermal loading limitations imposed when using the HLU in a Controlled Environmental Vault (CEV) or other enclosures are determined by applying its power parameters to the manufacturer's requirements for each specific housing.

The 42.5 Vdc Power Consumption is the maximum total power that the HLU-231 consumes or draws from the shelf power source. This parameter is needed when the HLU-231 is in a location remote to the CO it is serving. It determines the battery capacity required to maintain an 8-hour, stand-by battery reserve for emergency situations. Battery capacity, therefore, limits the maximum number of line units which can be installed in a remote enclosure. Use the data in [Table 17](#) through [Table 24](#) to perform this analysis on a case by case basis.

## MAXIMUM CURRENT DRAIN

The Maximum Current Drain is the maximum current drawn from the shelf power supply when its at its minimum voltage (-42.5 Vdc). This determines the shelf fusing requirements. Use the 42.5 Vdc current data in [Table 17](#) through [Table 24](#) to determine the shelf fusing requirements for your particular HLU applications.

# HLU-231 LIST 8A CARD CONNECTOR

Figure 29 shows the card-edge connector on the HLU-231 List 8A. Active pins are highlighted in black.

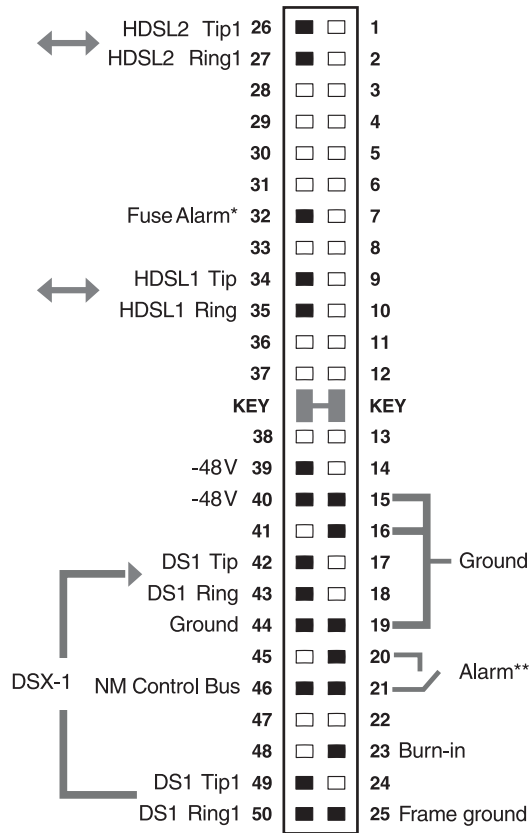

\* Fuse alarm is normally floating and at -48V when activated.

\*\* System minor alarm contacts (pins 20 and 21) are normally open and close upon alarm.

Figure 29. HLU-231 List 8A Card-edge Connector

## Network Management Control Bus

The HLU-231 List 8A provides a Network Management Control Bus on pin 46 of the card-edge connector. This allows the various PairGain Management System protocols to manage the HLU through the HMU-319 HiGain Management Unit. Whenever the HLU-231 is under management, the MNGD message displays periodically on the HLU front-panel display.



**Some HLU-231 List 8A features are affected when it is under management. Consult the management unit practice for further information.**

## Fuse Alarm

Pin 32 on the card-edge connector is a Fuse Alarm that is driven to -48 Vdc through a 1000 Ω resistor whenever the onboard fuse opens.

## System Alarm Relay Output

The normally open alarm contacts available across pins 20 and 21 (Figure 29 on page 58) comprise the HLU-231 List 8A system alarm output. These alarm contacts close for any system alarms condition. (See “View Troubleshooting Screen” on page 37 for further information.)

## CRAFT PORT

Figure 30 shows the pinout for the craft port connector and its connection to a DB-9 or DB-25 connector on a maintenance terminal.

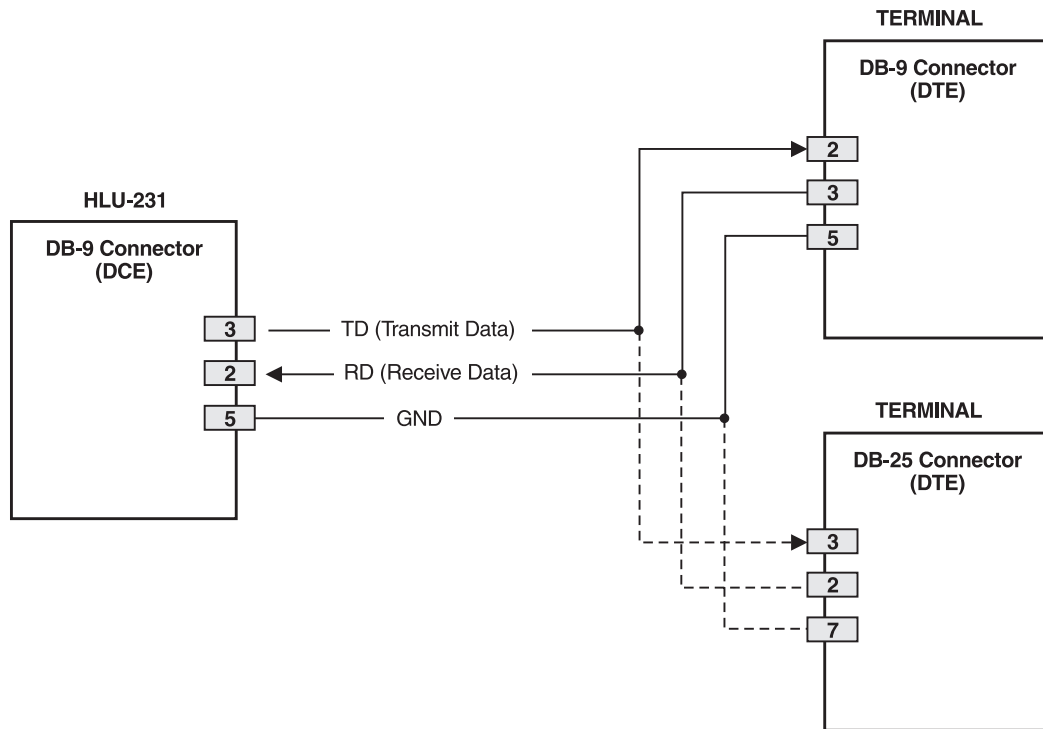

**Figure 30.** RS-232 Craft Port Pinouts

# APPENDIX B - FUNCTIONAL OPERATION

PairGain HDSL technology provides full-duplex services at standard T1 rates over copper wires between an HLU and an HRU, which comprise one HiGain system. HiGain systems use PairGain 2-Binary 1-Quaternary (2B1Q) HDSL transceiver systems to establish two, full-duplex, 784 kbps data channels between the HLU-231 and a remotely located HDU or HRU. This provides a total capacity of 1.568 Mbps between the two units.

A block diagram of the HLU-231 is shown in Figure 31. The HLU-231 receives a 1.544 Mbps DSX-1 data stream from the DSX-1 digital cross connect interface. The HLU-231 contains a DS1 frame synchronizer controlled by an 8-bit microprocessor that determines the type of framing on the DS1 stream and synchronizes to it. The HLU-231 recognizes Superframe (SF), including D4, or Extended Superframe (ESF) framing. When the data is unframed, the HLU-231 arbitrarily defines a frame bit.

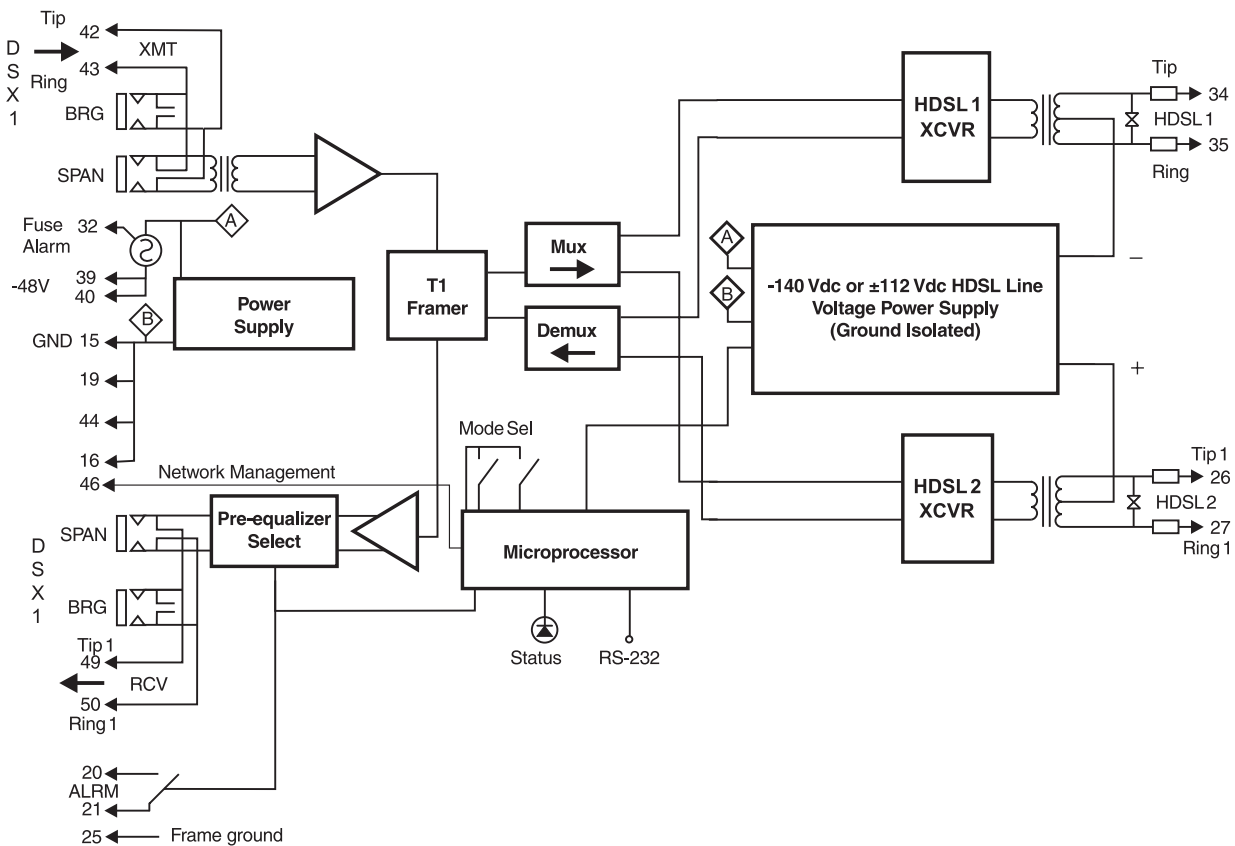

Figure 31. HLU-231 List 8A Block Diagram

## TIMING

The low loop wander (0.3 UI max) of an HLU-231 List 8A, when used with compatible doublers (HDU-409, HDU-404 or HDU-407) and remote units (HRU-402 or HRU-411), allows the circuit to be used in all critical timing applications, including those that are used to transport Stratum 1 timing.

## GROUND FAULT DETECT

The HLU-231 has a Ground Fault Detect (GFD) circuit which detects a ground or a resistive path to ground on any wire of any loop of any span with a non-zero voltage. For low (-140 Vdc) applications, such a circuit is active during start-up by applying the bipolar voltage to the loops. It deactivates when going to the nominal operation mode of unipolar negative voltage (0 Vdc and -140 Vdc). The circuit is constantly active during high ( $\pm 112$  Vdc) applications.

When the circuit is active, the system is compliant with Class A2 requirements of GR-1089. When the circuit is not active, the system is compliant with Class A3 requirements of GR-1089.

Whenever the GFD circuit detects a grounded loop, the line power is immediately removed from the spans and a PWR FEED GND alarm is generated and displayed. The power is reapplied 30 seconds later as part of a new start-up procedure. If the ground condition persists on the span, the power is removed again once the GFD circuit detects the grounded loop.

The indication of the location of the ground fault can be obtained by monitoring the voltages on the spans on the HLU side as it sequentially powers devices in subsequent spans.

# APPENDIX C - COMPATIBILITY

The HiGain system uses HDSL transmission technology as recommended by Bellcore TA-TSY-001210. The HiGain system complies with GR-63-CORE, TR-TSY-000499, and GR-1089-CORE.

## T1 REPEATER SHELVES AND RELATED EQUIPMENT

The HLU-231 List 8A is compatible with the following T1 repeater shelves and associated equipment:

- PairGain HCS-417 (23")
- PairGain HCS-418 (19")
- PairGain HCS-402 (2-slot)
- AT&T 220 Office Repeater Bay (ORB)
- AT&T Small Cross Section Shelf (SXSS)
- Kentrox 220
- Wescom® 342-30



**The ALM option must be disabled (DIS) when using the Kentrox 220 T-Term shelf. This is required to resolve a conflict between the HLU alarm relay output and the Kentrox external equalizer output. Both use pins 20 and 21.**

## HIGAIN DOUBLER CIRCUIT DEPLOYMENT

All generations of HiGain HLU and HRU modules are compatible with each other. Although all HiGain doublers are backward-compatible with all prior HLU and HRU models, some of the circuit application enhancements of newer doubler models require that all circuit modules be of the same vintage in order to realize these enhancements. Enhanced doubler applications preclude the mixing of newer doubler models with older models of the HRU and HLU.

Table 25 on page 63 provides a matrix of HiGain doubler deployment rules to achieve maximum circuit enhancement. It lists:

- Maximum number of doublers allowed for a given circuit, depending upon the doubler and line unit models used to implement the circuit.
- Any restrictions on the HRU models.



**All spans are fully CSA-compliant unless otherwise specified. Circuits that use more than one type of doubler are governed by the most limiting doubler rules. For example, if the HDU-451 is used with the HDU-409, use the HDU-451 deployment rules.**



**Table 25. HiGain Doubler Deployment Matrix**

HLU Model	Maximum Number of Doublers Per Circuit <sup>(a)</sup>											
	HDU-451, List 3, 3B, 4, 4B				HDU-437, 439				HDU-404, 407, 409			
	Line Powered		Local Powered		Line Powered		Local Powered		Line Powered		Local Powered	
	I-CPE ON	I-CPE OFF	I-CPE ON	I-CPE OFF	I-CPE ON	I-CPE OFF	I-CPE ON	I-CPE OFF	I-CPE ON	I-CPE OFF	I-CPE ON	I-CPE OFF
HLU-231 List 3D/6D HLU-319 List 2X; HLU-388 List 2X	1	1	2	2	1	1	2	2	1	1	2	2
HLU-231, List 7X; HLU-431, List 1D	1	1	2	2	1	2 <sup>(b)</sup>	2	2	1	2	2	2
HLU-231, Lists 8X; HLU-319, Lists 5X; HLU-388 Lists 5X	1	2 <sup>(c)</sup>	2	2	1	2	2	2	2	3 <sup>(c)</sup>	2	4 <sup>(d)</sup>
HLU-431 List 1F	0	0	1	1	0	0	1	1	1	1	1	2

(a) HRU-411 applications with I-CPE "on" are limited to single doubler circuits (HDU-404, HDU-407 or HDU-409) using HLU-231, Lists 8/8D/8E; HLU-319, Lists 5/5D/5E; and HLU-388 Lists 5/5D/5E. The HRU-412, HDU-451, HDU-437 and HDU-439 are limited to applications with one and two doublers only.

(b) 2000  $\Omega$  maximum loop resistance. Requires HRU-412, List 7A, L8A or HRU-402 or HRU-411.

(c) Requires HRU-402 or 411.

(d) Requires a locally powered HRU-402.

# APPENDIX D - PRODUCT SUPPORT

PairGain Customer Service Group provides expert pre-sales and post-sales support and training for all its products.

## TECHNICAL SUPPORT

Technical assistance is available 24 hours a day, 7 days a week by contacting PairGain Customer Service Group at:

<b>Telephone:</b>	800.638.0031 or 714.832.9922 The 800 telephone support line is toll-free in the U.S. and Canada.
<b>Fax:</b>	714.832.9924
<b>Email</b>	<a href="mailto:support@pairgain.com">support@pairgain.com</a>

During normal business hours (7:30 AM to 5:30 PM, Pacific Time, Monday through Friday, excluding holidays), technical assistance calls are normally answered directly by a Customer Service Engineer. At other times, a request for technical assistance is handled by an on-duty Customer Service Engineer through a callback process. This process normally results in a callback within 30 minutes of initiating the request.

## WORLD WIDE WEB

PairGain product and company information can be found at <http://www.pairgain.com> using any Web browser. To download PairGain product manuals from the Customer Site portion of the PairGain Web page, you need to provide a customer password. If you do not have a password, contact your PairGain sales representative.

## RETURNS

To return equipment to PairGain:

- 1 Locate the number of the purchase order under which the equipment was purchased. You will need to provide this number to PairGain's Sales Administration, RMA Department, to obtain a return authorization.
- 2 Call or write PairGain's Sales Administration, RMA Department, to ask for a Return Material Authorization (RMA) number and any additional instructions. Use the telephone number, fax number or email address, listed below:
  - Telephone: 800.370.9670
  - Fax: 714.832.9923
  - Email Address: [rma@pairgain.com](mailto:rma@pairgain.com)
- 3 Include the following information, in writing, along with the equipment you are returning:
  - Company name, address, the name of a person PairGain can contact regarding this equipment, and a phone number.
  - The purchase order number provided to the RMA Department when the RMA number was requested.

- A description of the equipment, as well as the number of units that you are returning. Be sure to include the model and part number of each unit.
- The shipping address to which PairGain should return the repaired equipment.
- The reason for the return:
  - The equipment needs an ECO/ECN upgrade.
  - The equipment is defective.



**If the equipment is defective, please tell us what you observed just before the equipment malfunctioned. Be as detailed in your description as possible.**

- If there is another reason for returning the equipment, please let us know so we can determine how best to help you.

- 4 Pack the equipment in a shipping carton.
- 5 Write PairGain's address and the Return Material Authorization (RMA) Number you received from the RMA Department clearly on the outside of the carton and return to:

PairGain Technologies, Inc.  
14352 Franklin Ave.  
Tustin, CA 92780-7013

Attention: **CRF RMA (Number)**



**All shipments are to be returned prepaid. PairGain will not accept any collect shipments.**

# APPENDIX E - GLOSSARY

<b>2B1Q</b>	2 Binary, 1 Quaternary	<b>DSX-1</b>	DS1 Cross-connect Frame
<b>ACO</b>	Alarm Cut Off	<b>ECI</b>	Equipment Catalog Item
<b>AIS</b>	Alarm Indication Signal indicated by transmission of an all ones pattern	<b>ENA</b>	Enabled
<b>ALMP</b>	Alarm Pattern	<b>ENFT</b>	Enable Fractional T1
<b>AMI</b>	Alternate Mark Inversion	<b>ES</b>	Errored Seconds
<b>AWG</b>	American Wire Gauge	<b>ESF</b>	Extended SuperFrame
<b>B8ZS</b>	Bipolar with 8-zero Substitution	<b>ESF DL</b>	Extended SuperFrame Data Link
<b>BBS</b>	Bulletin Board System	<b>HCDS</b>	High Capacity Digital Service
<b>BER</b>	Bit Error Rate	<b>HCS</b>	HiGain Central Office Shelf
<b>BPV</b>	Bipolar Violation	<b>HDSL</b>	High-bit-rate Digital Subscriber Line
<b>BPVT</b>	Bipolar Violation Transparency	<b>HDU</b>	HiGain Doubler Unit
		<b>HLU</b>	HiGain Line Unit
<b>CDI</b>	Customer Disconnect Indicator	<b>HMS</b>	HiGain Management Shelf
<b>CI</b>	Customer Installation	<b>HMU</b>	HiGain Management Unit
<b>CLEI</b>	Common Language Equipment Identifier	<b>HRE</b>	HiGain Remote Enclosure
<b>CLOC</b>	Customer Local Loopback	<b>HRU</b>	HiGain Remote Unit
<b>CO</b>	Central Office	<b>I-CPE</b>	Current (amperes) requirements for Customer Premises Equipment
<b>COM</b>	Communications	<b>ILR</b>	Intelligent Line Repeater
<b>CPE</b>	Customer Premises Equipment	<b>IOR</b>	Intelligent Office Repeater
<b>CRC</b>	Cyclic Redundancy Check	<b>IR</b>	Intelligent Repeater
<b>CREM</b>	Customer Remote Loopback	<b>LED</b>	Light Emitting Diode
<b>CSA</b>	Carrier Service Area	<b>LOS</b>	Loss of Signal
<b>CSU</b>	Channel Service Unit	<b>LOSW</b>	Loss of Sync Word
<b>DCE</b>	Data Circuit-Terminating Equipment	<b>NEBS</b>	Network Equipment Building System
<b>DDS</b>	Digital Data Service	<b>NEC</b>	National Electric Code
<b>DIS</b>	Disabled	<b>NI</b>	Network Interface
<b>DLC</b>	Digital Loop Carrier	<b>NID</b>	Network Interface Device
<b>DS0</b>	Digital Signal, level 0	<b>NIU</b>	Network Interface Unit
<b>DS1</b>	Digital Signal, level 1	<b>NLOC</b>	Network Local Loopback

---

<b>NMA</b>	Network Management and Administration	<b>RMA</b>	Return Material Authorization
<b>NREM</b>	Network Remote Loopback	<b>SAIS</b>	SmartJack AIS
<b>NVRAM</b>	Non-Volatile Random Access Memory	<b>SF</b>	Super Frame
<b>ORB</b>	Office Repeater Bay	<b>SMJK</b>	SmartJack
<b>PCS</b>	Personal Communication Services	<b>SNR</b>	Signal-to-Noise Ratio
<b>PL</b>	Payload	<b>SPLB</b>	Special Loopback
<b>POTS</b>	Plain Old Telephone Service	<b>STS</b>	Span Terminating Shelf
<b>PPM</b>	Pulse Position Modulation	<b>TEC</b>	Total Error Count
<b>PWRF</b>	Power Feed	<b>TLOS-LB</b>	Transmit Loss of Signal-Loopback
<b>RCV</b>	Receive	<b>TSEC</b>	Total System Error Count
<b>RDA</b>	Remote DS1 Alarm	<b>TSGR</b>	Transport System Generic Requirements
<b>RLOS</b>	Remote Loss of Signal	<b>UAS</b>	Unavailable Seconds
		<b>XMT</b>	Transmit



---

# CERTIFICATION AND WARRANTY

## FCC COMPLIANCE

This equipment has been tested and found to comply with the limits for a Class A digital device, pursuant to part 15 of the FCC Rules. These limits are designed to provide reasonable protection against harmful interference when the equipment is operated in a commercial environment. This equipment generates, uses, and can radiate radio frequency energy and, if not installed and used in accordance with the instruction manual, may cause harmful interference to radio communications. Operation of this equipment in a residential area is likely to cause harmful interference in which case the user will be required to correct the interference at his own expense.

## LIMITED WARRANTY

PairGain Technologies warrants this product to be free of defects and to be fully functional for a period of 60 months from the date of original shipment, given correct customer installation and regular maintenance. PairGain will repair or replace at PairGain's option any unit without cost during this period if the unit is found to be defective for any reason other than abuse or incorrect use or installation.

Do not try to repair the unit. If it fails, replace it with another unit and return the faulty unit to PairGain for repair. Any modifications of the unit by anyone other than an authorized PairGain representative voids the warranty.

If a unit needs repair, call PairGain for a Return Material Authorization (RMA) number and return the defective unit, freight prepaid, along with a brief description of the problem, to:

PairGain Technologies, Inc.  
14352 Franklin Avenue  
Tustin, CA 92780-7013  
ATTN: Repair and Return Dept.  
800.638.0031

Refer to the instructions under "[Returns](#)" on [page 64](#) for complete return instructions.

PairGain continues to repair faulty modules beyond the warranty program at a nominal charge. Contact your PairGain sales representative for details and pricing.

## MODIFICATIONS

Any changes or modifications made to this device that are not expressly approved by PairGain Technologies, Inc. may void the user's warranty.

All wiring external to the products should follow the provisions of the current edition of the National Electrical Code.

## STANDARDS COMPLIANCE

The HLU-231 List 8A has been tested and verified to comply with the applicable sections of the following standards.

- GR 63-CORE - Network Equipment-Building System (NEBS) Requirements: Physical Protection
- GR 1089-CORE - Electromagnetic Compatibility and Electrical Safety

For technical assistance, refer to "[Appendix D - Product Support](#)" on [page 64](#).

---

---

**Corporate Office**

14402 Franklin Avenue  
Tustin, CA 92780-7013

Tel: 714.832.9922

Fax: 714.832.9924

**For Technical Assistance:**

800.638.0031



---

**PAIRGAIN**