

HIGAIN LINE UNIT

Model	List Number	Part Number	CLEI Code
HLU-431	1E	150-1504-15	T1L2FVDAAA

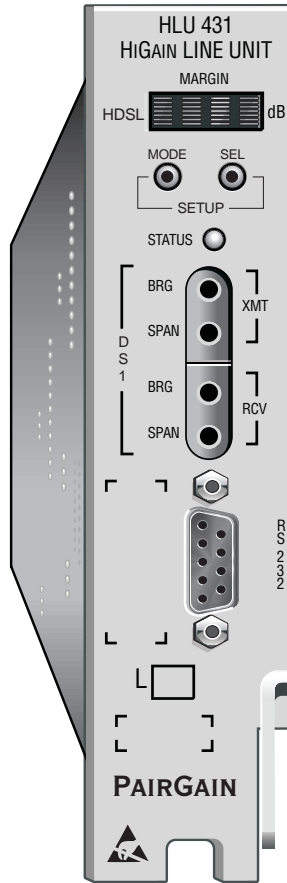

PAIRGAIN TECHNOLOGIES, INC.
ENGINEERING SERVICES TECHNICAL PRACTICE



SECTION 150-431-115-01

REVISION HISTORY OF THIS PRACTICE

Revision	Release Date	Revisions Made
01	September 22, 1998	Initial release

©Copyright 1998 PairGain Technologies, Inc.

PairGain and HiGain are registered trademarks of PairGain Technologies, Inc.

Information contained in this document is company private to PairGain Technologies, Inc., and shall not be modified, used, copied, reproduced or disclosed in whole or in part without the written consent of PairGain.

Other product names mentioned in this practice are used for identification purposes only and may be trademarks or registered trademarks of their respective companies.

USING THIS TECHNICAL PRACTICE

Two types of messages, identified by icons, appear in the text.



Notes contain information about special circumstances.



Cautions indicate the possibility of equipment damage or the possibility of personal injury.

INSPECTING SHIPMENT

Upon receipt of the equipment:

- Unpack each container and visually inspect it for signs of damage. If the equipment has been damaged in transit, immediately report the extent of damage to the transportation company and to PairGain. Order replacement equipment, if necessary.
- Check the packing list to ensure complete and accurate shipment of each listed item. If the shipment is short or irregular, contact PairGain as described in the Warranty. If you must store the equipment for a prolonged period, store the equipment in its original container.

TABLE OF CONTENTS

Overview	1
New Features.....	1
Applications	2
Applications without HiGain Doublers	2
Applications with HiGain Doublers	3
Product Description.....	3
Front Panel.....	4
Status LED.....	5
Front Panel Display	6
HLU-431 List 1E Card Connector.....	8
Network Management Control Bus	8
Fuse Alarm	8
System Alarm Relay Output.....	9
Installation	9
Provisioning the HLU-431	10
Setting Options through SEL and MODE.....	10
Factory Default Values	10
Displaying System Inventory	11
Connecting to a Maintenance Terminal	11
Maintenance	13
Navigating the Maintenance Terminal Screens	13
System Spans	13
Navigation Keys	13
Selecting an Option	14
Initializing the Maintenance Terminal Screens	14
Maintenance Terminal Main Menu.....	14
View Span Status	15
Span Status Screen: Non-Doubler Applications.....	15
Span Status Screen: Doubler Applications.....	15
Span Status Fields, Alarms, and Loopbacks.....	17
Set Clock.....	19
Set Time.....	20
Set Date.....	20
Update the HRU Time and Date.....	20

System Settings	21
DS0 Blocking Option.....	21
DS1 Line Code Option.....	22
Margin Alarm Threshold	22
HAIS Selections	23
HDSL Line Voltage Operation	23
Ground Fault Detect.....	23
System Settings Screen Options	24
Loopback Menu.....	26
Loopback Menu: No Doubler	26
Loopback Menu: Two Doublers	27
Initiating a Loopback	27
Disable Loopbacks.....	28
Performance Data Screens.....	28
Performance Data Screen: No Doubler.....	29
Performance Data Screen: With Doubler.....	30
View Performance History	30
The 7 Day History Screen: No Doubler.....	31
The 7 Day History Screen: With Doubler.....	31
View Alarm History	32
Alarm History Screen: No Doubler	33
Alarm History Screen: With Doubler	34
Circuit ID.....	34
System Alarms	35
Retiring System Alarms	35
Self Test.....	36
Loopback Operation	36
SmartJack (SMJK) Loopback.....	36
Generic Loopback Code (GNLB)	36
Addressable Repeater Loopback Functions	36
Initiating Manual Loopback Sessions	37
Loopback Test Procedures	38
Loopback Operation without Doublers.....	39
Loopback Operation with Doublers	40
GNLB Loopback Test Procedures.....	41
A1LB, A2LB, and A5LB Test Procedures	42
A3LB and A4LB Test Procedures	44

Appendix A - Technical Specifications	46
Appendix B - Abbreviations	47
Appendix C - Functional Operation	49
Power Consumption without Doublers	50
Power Consumption: Without Doublers	50
Maximum Power Dissipation:	50
Maximum Power Consumption:	50
Maximum Current Drain:	50
Power Consumption: With Doublers	51
Appendix D - Compatibility	52
Mounting	52
HiGain Doubler Circuit Deployment	52
Appendix E - Product Support	53
Technical Support	53
Warranty	54
FCC Compliance	54
Modifications	55
Standards Compliance	55
Barcode and Configuration Number Information	56

LIST OF FIGURES

Figure 1. HLU-431 List 1E Front Panel	4
Figure 2. HLU-431 List 1E Card-Edge Connector.....	8
Figure 3. Installing the HLU-431 into a Shelf	9
Figure 4. DB-9 RS-232 I/O Pinouts.....	12
Figure 5. System Spans.....	13
Figure 6. Maintenance Terminal Main Menu	14
Figure 7. Span Status Screen (No Doubler).....	16
Figure 8. Span 1 Status Screen	16
Figure 9. Span 2 Status Screen	17
Figure 10. Set Clock Screen	19
Figure 11. System Settings Screen	21
Figure 12. Loopback Menu: No Doubler.....	26
Figure 13. Loopback Menu with Two Doublers.....	27
Figure 14. NLOC Loopback Mode in the Maintenance Terminal Main Menu.....	28
Figure 15. Performance Data Screen: No Doublers.....	29
Figure 16. Span 3 Performance Data Screen	30
Figure 17. 7 Day History Screen for Span 1 (No Doubler)	31
Figure 18. 7 Day History Screen Span 3	32
Figure 19. Alarm History Screen for Span 1	33
Figure 20. Alarm History Screen for Span 3	34
Figure 21. HLU-431 Non-Doubler Loopback Configurations	39
Figure 22. Doubler Loopback Configurations	40
Figure 23. HLU-431 Block Diagram	49
Figure 24. Bar Code Label and Configuration Number	56

LIST OF TABLES

Table 1. HDSL Loss Over Cables	2
Table 2. Front Panel Components and Labels.....	5
Table 3. Status LED Descriptions	5
Table 4. Front Panel Display Messages	6
Table 5. Navigational Keys on the Maintenance Terminal	13
Table 6. Maintenance Terminal Screens	15
Table 7. Span Status Fields and Descriptions	17
Table 8. HLU-431 Status Menu Messages: Alarms	18
Table 9. HLU-431 List 1E System Settings Screen Options	24
Table 10. Errored and Unavailable Seconds Definitions	29
Table 11. Alarm History Fields and Descriptions	33
Table 12. HDSL System Alarms	35
Table 13. SPLB Loopback Command Set.....	41
Table 14. Addressable 1, 2, 5 (A1LB, A2LB, A5LB) Repeater Loopback Commands	44
Table 15. Addressable 3 and 4 (A3LB and A4LB) Repeater Loopback Commands.....	45
Table 16. HLU-431 List 1E Power Parameters with HDU Doublers, List 1, 2, 3, & 4, and M/M	51
Table 17. HiGain Doubler Deployment Matrix	53
Table 18. Bar Code Label and Configuration Number Descriptions	56

OVERVIEW

The PairGain® HiGain® HLU-431 List 1E is the Central Office (CO) side of a repeaterless, T1 transmission system. When used in conjunction with a remote unit or HRU, the system provides 1.544 Mbps transmission on two unconditioned copper pairs over the full Carrier Service Area (CSA) range. This line unit can be used in applications with or without HDUs.

The CSA includes loops up to 12,000 feet of 24 AWG or 9,000 feet of 26 AWG wire, including bridged taps. The HiGain system uses HDSL transmission technology as recommended by Bellcore TA-TSY-001210. The HiGain system complies with GR-63 CORE, TR-TSY-000499 and GR1089 CORE.

NEW FEATURES

- Selectable DS-1 pre-equalizer
- 140 to 200 Vdc HDSL line power for doubler and HRU-412
- Front panel HDSL S/N margin display
- Compatible with any 400 mechanic shelf
- Selectable loopback activation codes
- RS-232 maintenance port
- Shelf Management interface
- Non-volatile front panel operator setup
- Front panel DS1 splitting and bridge access
- Lightning and power cross protection on HDSL interfaces
- 784 kbps full duplex 2B1Q HDSL transmission on two pairs
- Front panel status indicating LED
- On / Off front panel display power cycling
- DS1 LOS detector (125 consecutive zeros)
- Margin threshold alarm
- HDSL AIS and Smart-Jack AIS options
- Easy return to factory default user settings
- Circuit ID option
- Low power consumption

APPLICATIONS

HiGain systems provide a cost-effective, easy-to-deploy method for delivering T1 High Capacity Digital Service (HCDS) over metallic pairs.

- The service is deployed over two unconditioned, non-loaded copper pairs, yet it demonstrates a quality that is competitive with fiber optics.
- Conventional, in-line, T1 repeaters are not required.
- Cable pair conditioning, pair separation and bridged tap removal are not required.

Each loop has no more than 35 dB of loss at 196 kHz, with driving and terminating impedances of 135Ω.

Table 1 provides a “loss” guide for the various cable gauges at 196 kHz and 135Ω. The table applies to the HDSL cable pairs between the HLU, HRU, and HDU modules. In the absence of specific insertion loss measurement data, add 3 dB for each bridged tap and 1 dB for each cable gauge change.

Table 1. HDSL Loss Over Cables

Cable Gauge	Loop Loss at 196 kHz (dB/kft)	Loop Resistance (Ω per kft)
26 AWG/0.4 mm	3.88	83
24 AWG/0.51mm	2.84	52
22 AWG/0.61mm	2.18	32
19 AWG/0.91mm	1.54	16

In general, HiGain systems:

- operate with any number of other T1, POTS, Digital Data Service (DDS) or other HiGain systems sharing the same cable binder group
- can be used with customers requiring DS1 service on a temporary or permanent basis
- provide a means of quickly deploying service in advance of fiber-optic transmission systems.

With a HiGain system, service can be provided within hours. Fiber-optic systems can be installed incrementally and cut-over from the installed HiGain system when convenient to do so.

Applications without HiGain Doublers

This section addresses HLU-431 List 1E operation when used without doublers. For applications without doublers, the HLU-431 is directly connected to the HRU by the two HDSL cable pairs. The HLU-431 is compatible with all HiGain HRUs.

Applications with HiGain Doublers

For doubler applications, one or two doublers may be used in the HDSL loops between the HLU and HRU for a total of up to three spans.



For compatibility guidelines on mixing newer doublers with older HRU and HLU models, refer to [“HiGain Doubler Circuit Deployment” on page 52.](#)

PRODUCT DESCRIPTION

The HLU-431 includes:

- A front panel featuring:
 - A status display
 - System option buttons
 - Status LED
 - DSX-1 access jacks
 - RS-232 Craft port
 - CLEI/ECI bar code number
 - Configuration number
- Card-edge connector

Front Panel

The HLU-431 List 1E front panel is shown in [Figure 1](#). The front panel components are described in [Table 2](#) on [page 5](#).

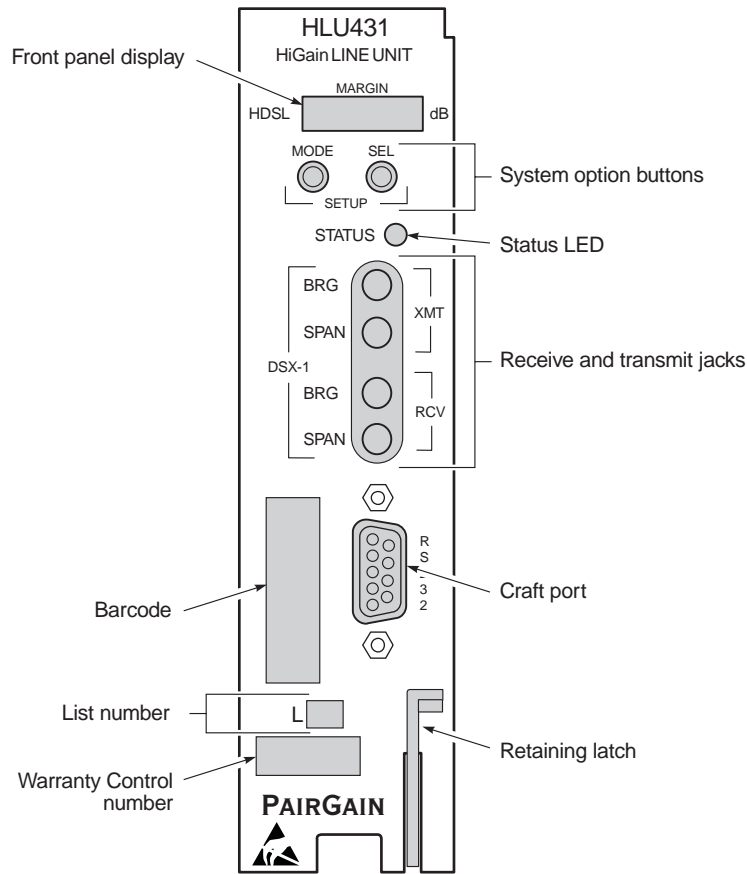

Figure 1. HLU-431 List 1E Front Panel

Table 2. *Front Panel Components and Labels*

Front Panel Feature	Function
Front panel display	Displays four-character status, provisioning, and alarm system messages.
System option buttons (MODE and SEL)	Permits the user options to be monitored and modified without the need of a maintenance terminal. Used to initiate all HiGain loopbacks and to display DSX-1 line parameters and line unit identity.
Status LED	See Table 3 for status descriptions.
DSX-1 access jacks	
SPAN	Provides splitting jack access to (XMT) and from (RCV), the HDSL span at the DSX-1 interface. Breaks the XMT and RCV paths to permit test signal insertion and retrieval.
BRIDGE	Provides non-intrusive bridging jack access to (XMT) and from (RCV) the HDSL span at the DSX-1 interface. Allows the two T1 payloads to be monitored.
Craft (RS-232) port	Provides bidirectional communication between the unit and an external terminal to allow configuration and performance monitoring through the Maintenance Terminal screens.
CLEI/ECI bar code label	Provides the human-readable Common Language Equipment Identifier (CLEI) code number and the Equipment Catalog Item (ECI) bar code number.
Configuration Number	The configuration number is a two or three-digit number that is either the last digits of a 5 or 6-digit warranty control number or is a standalone number of two or three digits. For example, a warranty control number of "80107" would indicate a warranty beginning in the year 1998 (8), during the month of January (01), and the unit's configuration number of 7 (07).

Status LED

[Table 3](#) describes the functions of the Status LED on the front panel.

Table 3. *Status LED Descriptions*

LED Status	Description
Green	Normal operation
Flashing green	HDSL acquisition
Red	Fuse Alarm
Flashing red	System alarm
Yellow	Self Test is in process or an HLU-431 List 1E Customer Remote Loopback (CREM) or a Network Local Loopback (NLOC) is in effect.
Flashing yellow	HLU-431 is in an Armed state

Front Panel Display

The front panel display is used with the MODE and SEL buttons to display system diagnostic messages. Refer to [Table 4](#) for a listing of the four character messages.

The front panel display turns on when power is initially applied to the HLU-431. To conserve power, the display only remains on for 4 minutes. The use of the MODE or SEL buttons activates the front panel display and restarts the 4-minute, power-control timer.

Table 4. Front Panel Display Messages

Message	Full Name	Description
CREM	Customer Remote Loopback	Signal from customer is looped back to customer at HLU-431.
NLOC	Network Local Loopback	DSX-1 signal is looped back to DSX-1 at HLU.
CLOC	Customer Local Loopback	Signal from customer is looped back to customer at HRU-412.
NREM	Network Remote Loopback	DSX-1 signal is looped back to DSX-1 at HRU.
SMJK	Remote Smart-Jack Loopback	DSX-1 signal is looped back to DSX-1 at HRU.
TLOS	Transmit Loss Of Signal	HRU is in a logic loopback state, caused by a loss of its DS1 input from the CI, when ENabled at the HRU via its TLOS switch option.
FERR	Framing Bit Error occurred	Framing bit error occurred at HLU DSX-1 input.
LBPV	Local Bipolar Violation	A bipolar violation has been received at the DSX-1 input to the HLU-431.
SIG1	Signal 1	The HLU and HRU transceivers are trying to establish contact with each other on loop 1.
SIG2	Signal 2	The HLU and HRU transceivers are trying to establish contact with each other on loop 2.
ACQ1	Acquisition 1	The HLU and HRU multiplexers are trying to establish synchronization over loop 1.
ACQ2	Acquisition 2	The HLU and HRU multiplexers are trying to establish synchronization over loop 2.
H1ES	HDSL CRC Error Channel 1	HLU HDSL loop 1 CRC error.
H2ES	HDSL CRC Error Channel 2	HLU HDSL loop 2 CRC error.
ARM	HiGain System is Armed	Armed and ready to respond to Intelligent Repeater loop codes.
ACO	Alarm CutOff	A minor alarm occurred and was retired to an ACO condition, after pressing the SEL button on the HLU front panel.
SELF-TEST	Self-test	The HLU is in a self-test mode. This occurs every power On/Off cycle.
ALRM	Alarm condition exists	A minor alarm condition is in effect.
1=xx	HDSL Loop 1 Margin	Indicates the power of the received HDSL signal on loop 1 relative to noise. Any value of "06" or greater is adequate for reliable system operation.
2=yy	HDSL Loop 2 Margin	Indicates the power of the received HDSL signal on loop 2 relative to noise. Any value of "06" or greater is adequate for reliable system operation.
PWR FEED SHRT	Power Feed Short	Indicates a short between the two HDSL pairs. This same message can occur with an HRU which is drawing the correct amount of power over good cable pairs, but can not communicate with the HLU.
PWR FEED OPEN	Power Feed Open	Indicates an open circuit in the T and R of either HDSL pair.

Table 4. *Front Panel Display Messages (Cont.)*

Message	Full Name	Description
PWR FEED OFF	Power Feed Off	HDSL span power has been turned off by setting the PWFD option to DIS.
BAD RT?	No response from HRU	The HLU does not receive any response from the HRU. Thus, the integrity of the HRU or the two HDSL loops (they may be open) is questionable.
VER XXXX	HLU software Version number	This is displayed during the System Settings review mode. Depress the Mode button for 3 seconds.
LIST XXXX	HLU's List number	Displayed during System Settings review mode defined above.
FRM	Frame: SF, ESF, UNFR, None	Defines the type of frame pattern being received from the DSX-1. Displayed during System Settings review mode defined above.
CODE	Line Code: AMI, B8ZS	The line code that HLU-431, List 1D is receiving at its DSX-1 interface, if the DS1 option is set to Auto. Otherwise, it mimics either of the other two DS1 line code settings, AMI or B8ZS. Displayed during System Settings review mode defined above.
LOSW	Loss of Sync Word	Indicates that one of the HDSL loops has lost sync. Causes a minor alarm.
LLOS	Local Loss of Signal	Indicates that no signal is detected at the DSX-1 input to the HLU. Causes a minor alarm.
RLOS	Remote Loss of Signal	Indicates that no signal is detected at the DSX-1 input to the HRU. Causes a minor alarm.
DS1	DS1 BPV Errors	Indicates that the number of BPVs at the HLU or HRU T1 inputs have exceeded the 24-hour ES threshold. Causes a minor alarm.
DS0	DS0 Blocked Channels	Indicates status of DS0 blocked channels. "None" indicates no channels are blocked. BLK indicates some channels are blocked.
MAL1	Margin Alarm Loop 1	The margin on HDSL loop 1 has dropped below the threshold (0 to 15 dB) set by the user.
MAL2	Margin Alarm Loop 2	The margin on HDSL loop 2 has dropped below the threshold (0 to 15 dB) set by the user.
MNGD	Managed	The HLU-431, List 1D is under control of the HMU-319 network management unit. In this state, the RS-232 maintenance port on the HLU-431's front panel is inoperative.

HLU-431 List 1E Card Connector

Figure 2 shows the card-edge connectors on the HLU-431. Active pins are highlighted in black.

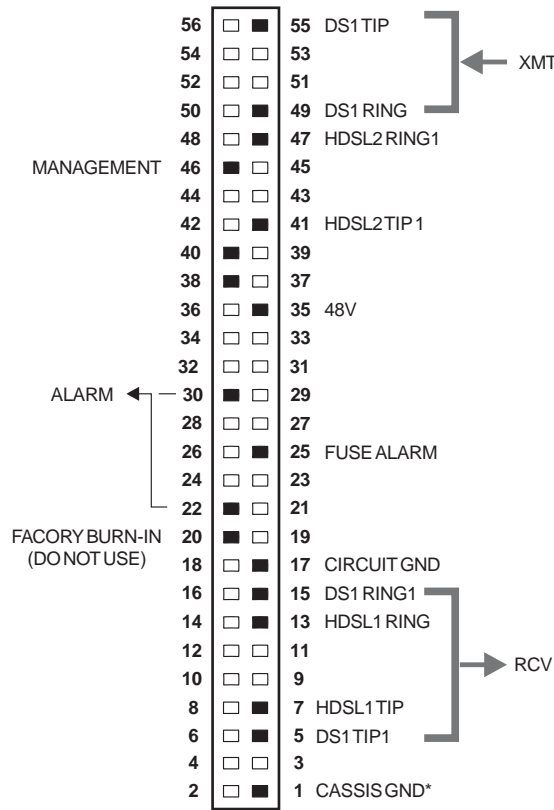

* Chassis GND may be tied to earth GND per local practice.

Figure 2. HLU-431 List 1E Card-Edge Connector

Network Management Control Bus

The HLU-431 List 1E provides a Network Management Control Bus on pin 46 of the card-edge connector. This allows the various PairGain Management System protocols to manage the HLU through the HMU-319 HiGain Management Unit. Whenever the HLU-431 is under management, the MNGD message displays periodically on the HLU-431 front panel display.



Some HLU-431 features are affected when it is under management. Consult the management unit practice for further information.

Fuse Alarm

Pin 25 on the card-edge connector is a Fuse Alarm that is driven to -48V through a 1000Ω resistor whenever the onboard fuse opens.

System Alarm Relay Output

The normally open alarm contacts available across pins 20 and 21 (Figure 2 on page 8) comprise the HLU-231 system alarm output. These alarm contacts close for any system alarms condition. This alarm contacts also close if power is lost or removed from the slot, providing fail-safe relay output. See “System Alarms” on page 35 for further information about system alarms.

INSTALLATION

To install the HLU-431:

- 1 Slide the HLU-431 into the card guides for the desired slot, then push the unit back until it touches the backplane card-edge connector and the retaining latch on the front panel opens (Figure 3).

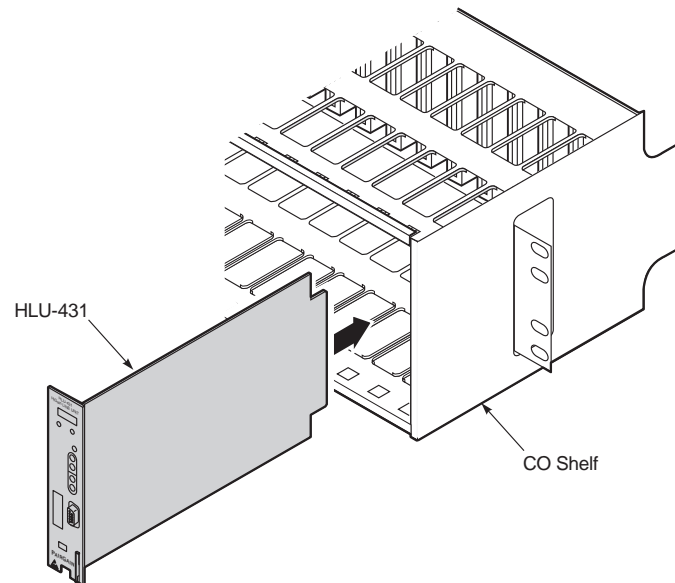

Figure 3. *Installing the HLU-431 into a Shelf*

- 2 Place your thumbs on the HLU-431 front panel and push the HLU-431 into the card-edge connector until it is entirely within the card guides and the retaining latch closes. This indicates that the card is properly seated.

PROVISIONING THE HLU-431

There are two methods for provisioning the HLU-431:

- Use the MODE and SEL buttons on the front panel
- Access system settings screens through the RS-232 Craft port.

No dip switches or jumpers are required to provision the HLU-431 as it contains a non-volatile RAM (NVRAM) which stores the system option settings. System settings are retained if shelf power is lost or if the HLU-431 is unplugged.

SETTING OPTIONS THROUGH SEL AND MODE

To provision the HLU-431 through the MODE and SEL buttons on the front panel:

- 1 Press the MODE button and release it after 1 second.

The message displayed on the front panel alternates between the first system parameter and its current setting.

- 2 Press the SEL button to step the display through all possible settings (one at a time) of the selected parameter.
- 3 After the desired setting has been selected, press the MODE button.

This updates the current displayed mode to the selected setting, and then advances to the next configurable parameter.

After the last parameter has been selected, a “Confirm? (Yes/No)” message appears on the front panel display.

- 4 Do one of the following:
 - To cancel the session without saving the requested parameter changes, press the MODE button. (Or, do nothing. After 30 seconds, the display returns to its normal mode without saving the new changes.)
 - To accept the requested parameter changes, press the SEL button. (A YES message displays, and the display returns to its normal mode after saving the new changes.)

In either case the display returns to its normal mode.

Factory Default Values

All user options can be set to the factory default values using the SEL and MODE buttons. To set the user options to their default values:

- 1 Press the SEL button for 6 seconds until the following message appears:

DFLT NO

- 2 Press the SEL button while the DFLT NO message is displayed.

The message changes to DFLT YES indicating the factory default values are now in effect.

To terminate the DFLT mode without setting the factory default values, do one of the following:

- Press the MODE button *or*
- Wait 30 seconds for the display to return to its normal state.

Displaying System Inventory

To scroll through an inventory of system parameters, press the MODE button for 3 or more seconds. The following parameters are displayed:

- HLU software version number
- HLU List number
- Type of frame pattern being received from the DSX-1
- Line code setting of the HLU
- Maximum insertion loss of each loop
- All 18 option settings



The line code parameter is the actual DSX-1 line code being received by the HLU if the DSX-1 code pattern is set to AUTO. Otherwise, the line code parameter mimics either of the other two line code settings, AMI or B8ZS.

CONNECTING TO A MAINTENANCE TERMINAL

The 9-pin, RS-232 Craft port on the front panel allows you to connect the HLU-431 to a maintenance terminal (ASCII terminal or PC running a terminal emulation program). Once connected to a maintenance terminal, you can access the maintenance, provisioning, and performance screens.

To connect to a maintenance terminal:

- 1 Connect a standard 9-pin terminal cable to the RS-232 Craft port on the HLU-431 front panel.
- 2 Connect the other end of the console cable to the console port on the maintenance terminal.
- 3 If necessary, start a terminal emulation program.
- 4 Configure the maintenance terminal to the following communication settings:
 - 1200 to 9600 baud (9600 baud is recommended)
 - no parity
 - 8 data bits
 - 1 stop bit
 - hardware flow control to OFF

A standard RS-232 (DB-9, female) connector on the front panel provides access to the screen interface feature through a maintenance terminal (Figure 4).

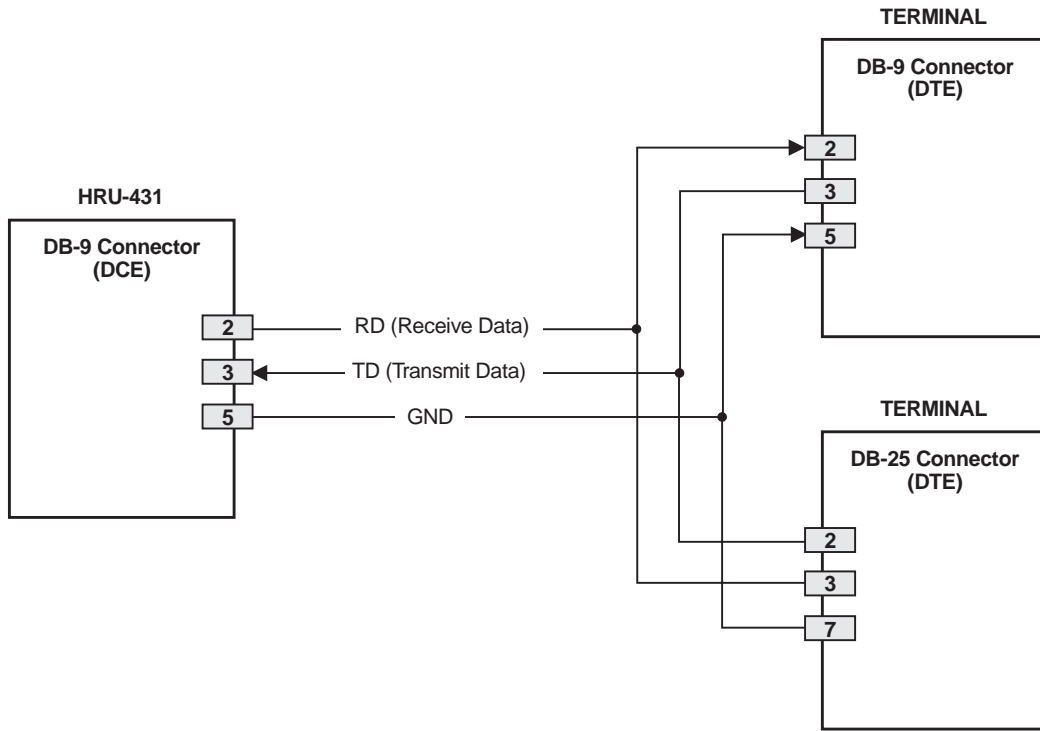

Figure 4. DB-9 RS-232 I/O Pinouts

MAINTENANCE

This section explains how to navigate through the Maintenance Terminal screens and describes the Main Menu and its various options.

NAVIGATING THE MAINTENANCE TERMINAL SCREENS

The following sections describe how the Maintenance Terminal displays an HLU-431 system with and without doublers, how to navigate through the maintenance screens, and how to select options.

System Spans

As shown in [Figure 5](#), the HLU can support up to two doublers with three HDSL spans. The Span Status, Performance Data, and Performance History may display as many as three screens to depict an HLU-431 system.

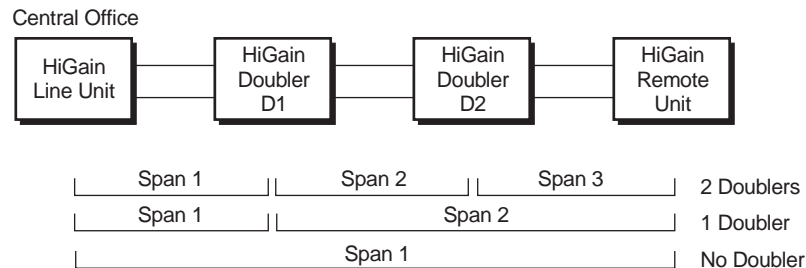

Figure 5. System Spans

Navigation Keys

[Table 5](#) lists keys you can use on the maintenance terminal to navigate within the Maintenance Terminal screens.

Table 5. Navigational Keys on the Maintenance Terminal

Key	Function
U	Updates a report
C	Clears a report
S	Selects the next Span Status screen
P	Selects the previous page of a report
N	Selects the next page of a report
E	Exits the current screen

Selecting an Option

To select an option within the Maintenance Terminal screens, you can:

- Press the key indicated to the left of the selection.
- Press the letter in parenthesis of the parameter to be changed.

An invalid entry produces the following message and identifies the name of a field where the invalid entry occurred:

```
> error
```

This happens only for Margin Alarm Threshold or DS0 blocking.

INITIALIZING THE MAINTENANCE TERMINAL SCREENS

Press the **SPACEBAR** several times to initiate the autobaud connection and to initialize the Maintenance Terminal screens.

MAINTENANCE TERMINAL MAIN MENU

Figure 6 shows the Maintenance Terminal Main Menu from which you can access eight system administration screens. The function of each screen selection is listed in Table 6.

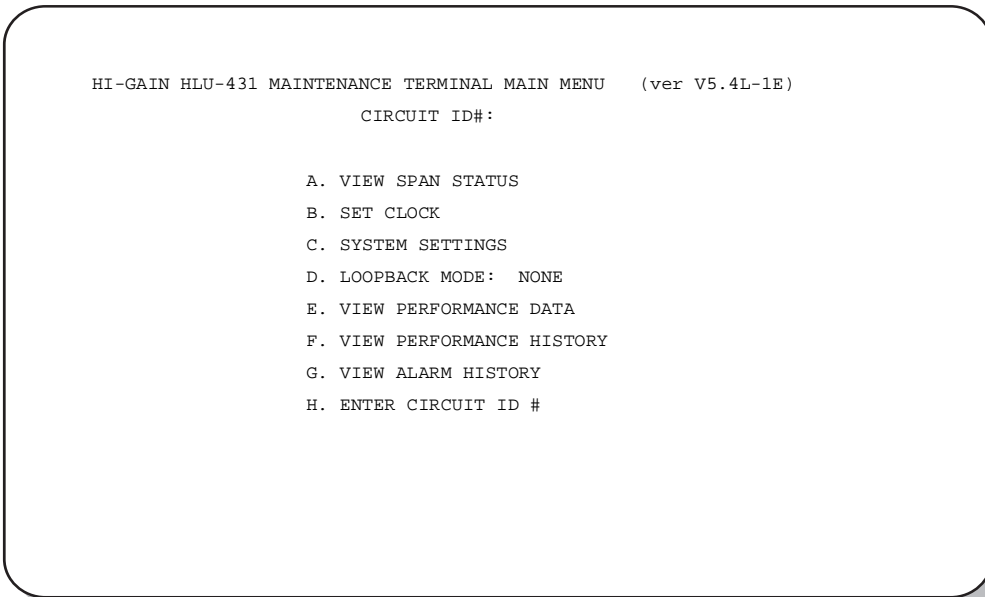

```
HI-GAIN HLU-431 MAINTENANCE TERMINAL MAIN MENU (ver V5.4L-1E)
CIRCUIT ID#:

A. VIEW SPAN STATUS
B. SET CLOCK
C. SYSTEM SETTINGS
D. LOOPBACK MODE: NONE
E. VIEW PERFORMANCE DATA
F. VIEW PERFORMANCE HISTORY
G. VIEW ALARM HISTORY
H. ENTER CIRCUIT ID #
```

Figure 6. Maintenance Terminal Main Menu

Table 6. Maintenance Terminal Screens

Screen	Function	See page:
View Span Status	Provides access to subscreens that allow you to monitor the HDSL line between the HLU and the HRU.	15
Set Clock	Allows you to set both the time and the date parameters at the HLU, and to update the same settings at the HRU.	19
System Settings	Allows you to set all user options.	21
Loopback Mode	Provides access to subscreens that allow you to issue and disable loopbacks at all circuit module locations.	26
View Performance Data	Provides access to subscreens that allow you to view the Errored Seconds (ES) and Unavailable Seconds (UAS) between the HLU and the HRU in 15-minute intervals over a 4-hour time period.	28
View Performance History	Provides access to subscreens that allow you to view the ES and UAS between the HLU and the HRU in 24-hour intervals over a 7-day period.	30
View Alarm History	Provides access to subscreens that allow you to view alarm conditions between the HLU and the HRU.	32
Enter Circuit ID #	Allows you to enter a unique circuit ID (up to 24 characters).	34

VIEW SPAN STATUS

The View Span Status option allows you to view four system status screens that provide information about the HDSL Loop 1, HDSL Loop 2, and the DS1. For doubler applications, the available Span Status screens depend on whether the system includes one or two doublers.

From each Span Status screen you can:

- Press **C** to clear the cur (current), min (minimum) and max (maximum) numeric counts.
- Press **U** to update cur (current) values.
- Press **S** to view the next available span.
- Press **E** to return to the previous screen.

Span Status Screen: Non-Doubler Applications

Press **A** from the Maintenance Terminal Main Menu to open the Span Status screen (Figure 7). If no doubler (HDU) is present, the screen reports span status for the subscriber lines between the HLU and the HRU.

Span Status Screen: Doubler Applications

If doublers have been added, status is also reported for these. After pressing **A** to access the Maintenance Terminal Main Menu, press **S** to navigate through the span status screens. Span Status can have up to four screens, depending on the number of HDUs. Figure 8 shows status between an HLU and its first doubler (HDU1). If there is only one doubler, the next screen (Figure 9) shows status between HDU1 and the HRU. If there are additional doublers the Span Status screen will report status on each span.

```

                                SPAN 2 STATUS
TIME: 12:06:04
DATE: 02/02/98                Circuit ID#:
ALARMS: NONE
LOOPBACK: OFF

                                HDU1                HRU
                                HDSL-1            HDSL-2
                                cur/min/max      cur/min/max
MARGIN:                21/21/21            21/21/21            21/21/21            21/21/21 dB
PULSE ATTN:                19                19                20                19 dB
INS LOSS:                23                23                25                23 dB
PPM OFFSET:                00                00                17                17 ppm
24 HOUR ES:                00000            00000            00000            00000 seconds
24 HOUR UAS:                00000            00000            00000            00000 seconds

                                DS1 STATUS
                                HLU                HRU
24 HOUR BPV Seconds:        00000            00000
24 HOUR UAS Count:         00000            00000
Frame type:                ESF                ESF
Code type:                 B8ZS                B8ZS

                                (E)xit (C)lear (U)pdate (S)pan

```

Figure 9. Span 2 Status Screen

Span Status Fields, Alarms, and Loopbacks

Table 7 lists the Span Status fields and descriptions. Table 8 on page 18 lists all possible alarms and loopbacks, and their descriptions.

Table 7. Span Status Fields and Descriptions

Field	Description
Time	Time of day when Span Status was checked.
Date	Date when Span Status was checked.
Circuit ID	Shows the user-defined circuit ID.
Alarms	Presence or absence of alarm conditions. See Table 12 on page 35.
Loopback	Indicates Off condition or identifies specific active loopback. See Table 13 on page 41.
Margin	Indicates the excess signal-to-noise ratio, at either the HLU or HRU, relative to a 10^{-7} Bit Error Ratio. The first value is the current margin, the second is the minimum margin, and the third is the maximum value. NA means "Not Available." The minimum and maximum margins are cleared and updated every time the Span Status screen is cleared and every time the system clock passes 12:00 AM midnight.
Pulse Attenuation (ATTN)	Indicates the attenuation of the 2B1Q pulse from the distant end. The value is related to the 196 kHz loss of the cable pair. The pulse attenuation is a more direct indication of the loop attenuation to the 2B1Q signal than is the 196 kHz loss. The normal HiGain ATTN operation range is from 0 to 28 dB.
Ins Loss	Indicates the approximate insertion loss of the various loops at the HDSL line rate of 196 KHz. It is generated by multiplying the PULSE ATTN by 1.25.
PPM Offset	Indicates the relative offset of the crystal oscillator in the HLU from the HRU or HDU crystal oscillator. Any value between -100 and +100 is adequate.

Table 7. *Span Status Fields and Descriptions (Cont.)*

Field	Description
24-Hour ES	The number of one second intervals that contained at least one CRC error. This value is a running total of the last 24 Hours.
24-Hour UAS	The number of seconds the HDSL loop was out of sync.
24-Hour BPV Seconds	The number of seconds in which at least one bipolar violation was detected on the DS1 input over a 24-hour period.
24-Hour UAS Count	The number of seconds during which the DS1 input signal was absent (125 or more consecutive 0s) over a 24-hour period.
Frame type	Type of DS1 framing used on the input stream (SF or ESF).
Code type	Type of DS1 line coding used (AMI, B8ZS, AMI: ZBTSI or B8ZS: ZBTSI). The latter two conditions indicate the code type that is being received when HiGain is set to its ZBTSI mode. In either the AMI or B8ZS DS1 code mode, it displays the selected code as opposed to the code type that is actually being received.

Table 8. *HLU-431 Status Menu Messages: Alarms*

Message	Full Name	Description
NONE		No Alarms
LLOS	Local Loss of Signal	No signal from HLU-231 List 1E local T1 interface.
RLOS	Remote Loss of Signal	No signal from HRU-412 remote T1 interface.
LOSW1(2)	Loss of Sync Word 1(2)	HDSL loop 1 or 2 has lost sync.
H1ES	HDSL Loop 1 Errored Second	Loop 1 CRC have exceeded the ES threshold.
H2ES	HDSL Loop 2 Errored Second	Loop 2 CRC have exceeded the ES threshold.
DS1	Digital Service 1	BPVs for either the HLU-231 List 1E or HRU-412 DS1 input have exceeded the user selected ES threshold.
R(L)AIS	Remote (Local) Alarm Indicating Signal	Indicates an AIS (all "1") pattern is being transmitted from the remote (local) T1 output port.
MAL1	Margin Alarm 1	The margin on HDSL loop 1 has dropped below the threshold (1 to 15 dB) set by the user. Setting the threshold to 0 inhibits the margin alarm.
MAL2	Margin Alarm 2	The margin on HDSL loop 2 has dropped below the threshold (1 to 15 dB) set by the user. Setting the threshold to 0 inhibits the margin alarm.
CHREV	Channels Reversed	The Loop 1 and Loop 2 HDSL pairs are reversed at the HDU-451 or HRU-412 line input ports. Loop 1 is specified to carry the (-) simplex DC voltage, and Loop 2 is specified to carry (+) simplex DC voltage.
SMJK	Smart-Jack Loopback	Loopback at HRU-412 remote towards network initiated by (2 in 5) in-band loopback code or out-of-band ESF data link code (Figure 15).
NREM	Network Remote Loopback	Loopback at HRU-412 (remote) towards network initiated from CO (network) by Intelligent Line Repeater (ILR) #2 code, HLU-231 front panel MANUAL LOOPBACK push-buttons, HRU-412 front panel push-button, or maintenance terminal (Figure 15).
NLOC	Network Local Loopback	Loopback at HLU-231 List 1E (local) towards network initiated from CO by IOR code, HLU-231 front panel MANUAL LOOPBACK push-buttons or maintenance terminal (Figure 15).

Table 8. HLU-431 Status Menu Messages: Alarms (Cont.)

Message	Full Name	Description
HDU1	Network Doubler 1 Loopback	Loopback at Doubler #1 towards network initiated by IOR code or HLU-231 front panel MANUAL LOOPBACK push-buttons or maintenance terminal (Figure 15).
HDU2	Network Doubler 2 Loopback	Loopback at Doubler #2 towards network initiated by IOR code or HLU-231 front panel MANUAL LOOPBACK push-buttons or maintenance terminal (Figure 15).
CLOC	Customer Local Loopback	Loopback at HRU-412 (local) towards CI initiated from CPE by ILR code or HLU-231 front panel MANUAL LOOPBACK push-button or maintenance terminal (Figure 15).
CREM	Customer Remote Loopback	Loopback at HLU-231 List 1E (remote) towards customer initiated by IOR code or HLU front panel MANUAL LOOPBACK push-buttons, or maintenance terminal (Figure 15).
CDU 1	Customer Doubler 1 Loopback	Loopback at Doubler 1 towards CI initiated by ILR code, HLU-231 front panel MANUAL LOOPBACK push-buttons, or maintenance terminal (Figure 15).
CDU 2	Customer Doubler 2 Loopback	Loopback at Doubler 2 towards CI initiated by ILR code, HLU-231 front panel MANUAL LOOPBACK push-buttons, or maintenance terminal (Figure 15).
ARM	Armed	The HiGain system has detected the IR loopback (2 in 5) arming code.
TLOS	Transmit Loss of Signal Loopback	HRU-412 is in a logic loopback state caused by a loss of its T1 input from the CI, if enabled at the HRU-412 via its TLOS switch option.

SET CLOCK

Press **B** from the Maintenance Terminal Main Menu to open the Set Clock screen (Figure 10).

SET CLOCK

TIME: 00:14:33
DATE: 02/02/98
CIRCUIT ID#:

Format: HH:MM
MM/DD/YY

NEW TIME:
NEW DATE:

(U)PDATE REMOTE?

Figure 10. Set Clock Screen



All time information is lost when power is removed. The last date, however, is retained in NVRAM and reappears when power is restored.

Set Time

The cursor defaults to the New Time field. To set the system time, type the hour and minute in the 24-hour format of **hh:mm:ss** (setting the seconds is optional), then press **ENTER**. The New Date field displays.

Set Date

To set the system date, type the month, day and year in a **mm/dd/yy** format, then press **ENTER**. The Update Remote field displays.



When editing entries in the Clock screen and when using the Terminal emulation program in Windows 3.1, pressing the **BACKSPACE key deletes two characters instead of just one.**

Update the HRU Time and Date

The remote unit date and time is set by using this option. To update the remote, do one of the following:

- Press **U** to update the HRU to the same date and time set for the HLU-431 *or*
- Press **ENTER**. (The remote unit is not updated.)



All time information is lost when power is removed. The last date, however, is retained in NVRAM and reappears when power is restored.

SYSTEM SETTINGS

The options set from the System Settings screen are the same as the options set through the HLU-431 front panel Mode and SEL buttons (except for Margin Alarm Threshold and DS0 Blocking, which can only be set at this screen). Refer to [Table 9 on page 24](#) for a listing of system setting options.

Press **C** from the Maintenance Terminal Main Menu to open the System Settings screen ([Figure 11](#)).

```

                                SYSTEM SETTINGS

TIME: 12:46:06
DATE: 02/02/98                                CIRCUIT ID#:

E(Q)UALIZATION:          EXT
SMART-JACK (L)B:         ENABLED
(S)PECIAL LPBK:          GNLB
(P)OWER:                  AUTO
(Z)BTSI:                  OFF
ES ALARM TH(R)ESH:       NONE
LOOPBACK (T)IMEOUT:      60
(A)LARM:                  DISABLED
(D)S1 LINE CODE:         AUTO
(F)RAMING:                AUTO
AIS ON (H)DSL LOSW:      2 LOOPS
AIS ON S(M)JK/NREM:      ENABLED
MAR(G)IN ALM THRES:     4
DS0 (B)LOCKING: xx - Blocked Channels
01 02 03 04 05 06 07 08 09 10 11 12 13 14 15 16 17 18 19 20 21 22 23 24

                                (E)xit
Enter the letter in parenthesis (X) to change any setting

```

Figure 11. System Settings Screen

To change any option:

- 1 Enter its character key, which is shown inside the parenthesis within each parameter description. This causes the screen to refresh with the new settings.
- 2 After all parameters have been selected, press **E** to exit, then **C** to confirm. The newly selected parameters are now activated.

DS0 Blocking Option

To set the DS0 Blocking option from the Main screen:

- 1 Press **C** to select the Systems Settings screen (see [Figure 11 on page 21](#)).
- 2 Press **B** for the DS0 blocking selection. The DS0 channels are blocked or unblocked by entering each channel number. Multiple channels can be selected by inserting a space between each entry.
- 3 After all the new settings have been made, press **E** for (Exit) then **C** to (Confirm). The new choices are now installed.

If DS0 blocking is invoked in a HiGain system that has an earlier version HRU that does not support the blocking option, blocking only occurs at the DSX-1 output of the HLU-431. The HRU DS1 output will not be blocked. Also, all blocked channels are temporarily unblocked for all HiGain system loopback tests for all DS1 blocking settings. This allows the standard full bandwidth T1 loopback tests to be performed for all DS0 blocking settings.

If a customer of a fractional T1 service fills any of the unused DS0 channels with information other than an idle code of all ones, the HiGain system blocks this information from reaching the remote end of the circuit and replaces those DS0 channels with an all ones idle code.

The result of blocking the idle code is that the CRC checksum delivered to the remote end (when the payload is in the BSF format) will not match the checksum calculated by the remote T1 CSU. This implies errors are being made on the loop when actually the blocking function created the CRC errors. Enabled DS0 channels pass error-free.

In order to avoid this condition, fractional T1 customers should fill the unused time slots with an idle code. This is a common capability on Fractional T1 CSU/DSU, D4 channel banks, and other CPE devices capable of connecting to Fractional T1 service.

DS1 Line Code Option

The DS1 line code option should always be set to conform to the type of DS1 service, AMI or B8ZS, being provided by the HiGain system. The AUTO mode, which can adapt to either AMI or B8ZS, should only be used in applications that require it (such as when HiGain acts as a standby circuit to DS1 circuits whose line codes are not known or may be both AMI and B8ZS) since it has the following two limitations. The AUTO mode will induce one BPV in the DS1 bit stream whenever it switches from AMI to B8ZS. The AUTO mode allows each HiGain end, HLU and HRU, to set its DS1 mode to the code it is receiving at its local DS1 input port. This makes each unit's code independent of the DS1 code being received at the distant DS1 input port. Thus if the line codes being received by HiGain are different in each of the two DS1 directions, the HiGain DS1 output codes will not match their respective DS1 input codes at the other end. This could cause the customer's received data to be AMI instead of B8ZS and thus violate the one's density rules by having excessive zeroes.

Margin Alarm Threshold

To set the Margin Alarm Threshold:

- 1 Select **G** from the System Settings Main Menu screen.
- 2 Enter the desired minimum acceptable alarm threshold from the 0 to 15 dB range. This causes a system alarm to occur if either the margin on HDSL loop 1 (MAL1) or loop 2 (MAL2) drops below the selected threshold value.



Since the margin can never drop below 0, choosing **0** for the margin threshold turns the margin alarm off.

HAIS Selections

The HAIS option provides two selections for the T1 transmit outputs at both the HLU-431 and HRU for HDSL loss of sync conditions.

- **1LP** causes the AIS (LOS if ALMP is set to LOS) pattern to be transmitted at both T1 outputs when either of the two HDSL loops experience an out-of-sync (LOSW) condition or when a margin alarm occurs. 1LP causes the 12 channels on the surviving loop to be lost as they are replaced by the AIS/LOS pattern. However, it does notify downstream and upstream equipment of the loss of one HDSL loop or a loop with low margin. This is the preferred setting for initiating an AIS/LOS state with just one conductor open in either of the HDSL pairs. Short loops, below approximately 16 dB of loss at 200 kHz, can remain in sync with one conductor open. Since the loop is still in sync, no LOSW condition occurs. However, the margin on a one-conductor loop drops from 5 to 10 dB. Thus, if the Margin alarm is set to 5 dB below the normal margin at turn-up, when one conductor does open, a system alarm occurs and causes the AIS/LOS condition. This alerts the maintenance personnel of the problem.
- **2LP** requires both HDSL loops to be out of sync (LOSW) before the HAIS signal is transmitted. 2LP preserves the integrity of the 12 surviving channels when just one loop is lost.

HDSL Line Voltage Operation

A unique feature of the HLU-431 List 1E is that its 200 V output voltage for doubler applications is always bipolar. This bipolar voltage is required to support the Ground Fault Detection (GFD) circuit, which is also unique to the HLU-431 List 1E. The 140 V output voltage used in non-doubler unit applications is always negative. This keeps the HDSL cable pair voltage at or below ground potential, thereby avoiding corrosion problems caused by cable voltages more positive than ground.

The specific bipolar voltage levels existing between ground and the two loops for a system containing doublers depends on the following factors:

- loop length
- number of doublers
- type of doublers (which List)
- whether the HRU is locally powered or line powered

The line voltage power supply is ground referenced, but also ground isolated by 200 kohms. This ground isolation reduces problems due to induced noise currents and large surge voltages, which are ground referenced. It also reduces ground fault currents, which improves product safety. Therefore, the product safety depends solely on the differential voltage across loop 1 and loop 2.

Ground Fault Detect

The HLU-431 List 1E has a GFD circuit that is compliant with paragraph R7-1, Section 7.2.1 of GR-1089-CORE, Issue 1, Revision 1, December, 1996.

The GFD circuit immediately detects ground faults that occur at any point along any span on any conductor, and shuts down the HiGain circuit. The HLU-431 then applies power periodically to the first span to detect the ground fault condition. This power cycling and ground fault protection continues as long as the fault condition exists.

System Settings Screen Options

Table 9 describes the System Settings screen options and their counterpart codes for the front panel display.

Table 9. HLU-431 List 1E System Settings Screen Options

System Settings Screen Options	Front Panel Display Code	Selection	Description
Equalization	EQL	0*	Sets the Equalizer to DSX-1 for 0 to 133 feet.
		133	Sets the Equalizer to DSX-1 for 133 to 266 feet.
		266	Sets the Equalizer to DSX-1 for 266 to 399 feet.
		399	Sets the Equalizer to DSX-1 for 399 to 533 feet.
		533	Sets the Equalizer to DSX-1 for 533 to 655 feet.
SmartJack Loopback	LBPK	DIS	Configures the HiGain system to ignore all in-band SmartJack loopback commands.
		ENA*	Enables the HiGain system to recognize all in-band SmartJack loopback commands.
Special Loopback	SPLB	GNLB*	Configures the HiGain system to respond to the generic (3- or 4-in-7) in-band loopback codes.
		A1LB and A2LB	Configures the HiGain system to respond to the in-band loopback codes of the Teltrend addressable repeater.
		A3LB	Configures the HiGain system to respond to the in-band loopback codes of the Wescom addressable repeater.
		A4LB	Configures the HiGain system to respond to the in-band loopback codes of the Wescom Mod 1 addressable repeater.
		A5LB	Configures the HiGain system to respond to the in-band loopback codes of the Teltrend Mod 1 addressable repeater.
Power	PWRF	DIS	Disables powering to the HDSL pair.
		ENA*	Allows the HDSL line voltage to automatically switch between -140V maximum for non-doubler applications and $\pm 100V$ for doubler applications.
ZBTSI	ZBTS	ON	Tells the HiGain system that the ESF frame is operating in its Zero-Byte Timeslot Interchange (ZBTSI) mode.
		OFF*	Tells the HiGain system that the ESF frame is operating in its normal non-ZBTSI mode.
ES Alarm Threshold	ESAL	17	Activates (closes) the minor alarm relay contacts on pins 20 and 21 and flashes the red STATUS LED when 17 errored seconds (ES) occur within a 24-hour period.
		170	Activates (closes) the minor alarm relay contacts on pins 20 and 21 and flashes the red STATUS LED when 170 errored seconds (ES) occur within a 24-hour period.
		NONE*	Prevents generation of a minor alarm due to errored seconds.

*Indicates factory default settings.

Table 9. HLU-431 List 1E System Settings Screen Options (Cont.)

System Settings Screen Options	Front Panel Display Code	Selection	Description
Loopback Timeout	LBTO	NONE	Disables automatic time-out cancellation of all loopbacks.
		20	Sets automatic cancellation of all loopbacks to 20 minutes after initiation.
		60*	Sets automatic cancellation of all loopbacks to 60 minutes after initiation.
		120	Sets automatic cancellation of all loopbacks to 120 minutes after initiation.
Alarm	ALM	DIS*	Opens the system alarm relay contacts if closed, and disables activation of the system alarm relay when a system alarm condition occurs.
		ENA	Enables activation of the system alarm relay when a system alarm condition occurs.
DSX-1 Line Code	DS1	AUTO	The HLU-431 and HRU monitors the incoming HRU T1 bit streams for the Bipolar with 8-zero Substitution (B8ZS) pattern. If the HRU detects this pattern, the HLU enters its B8ZS mode. It reverts back to its Alternate Mark Inversion (AMI) output mode if no B8ZS patterns are received at the HRU input for five seconds. The HLUs T1 input can detect either AMI or B8ZS when in the AUTO mode.
		B8ZS	Places both the HLU-431 and HRU into their B8ZS modes.
		AMI*	Places both the HLU-431 and HRU into their AMI modes.
Framing	FRMG	AUTO*	Configures the HiGain system to operate in an auto-framing (AUTO) mode in which it continuously searches the input T1 bit stream for a valid SF or ESF frame pattern. This feature is required for fractional T1 applications (DS0 blocking) where it insures proper channel time slot alignment. While the HiGain system can also process unframed data in this AUTO mode, it is recommended that the unframed (UNFR) mode be used for all unframed applications. Using the AUTO mode for unframed applications runs the risk of detecting "pseudo-valid" frame sequences, which can affect the data integrity.
		UNFR	Configures the HiGain system to operate in an unframed mode. This mode disables the auto framing process and forces the HiGain system to function as a transparent bit pipe.
AIS On HDSL LOSW	HAIS	2LP*	Causes the HiGain system to transmit the AIS signal at both the HLU-431 and HRU T1 output ports when both of the HDSL loops are not in sync (LOSW).
		1LP	Causes the HiGain system to transmit the AIS signal at both the HLU-431 and HRU T1 output ports when either of the two HDSL loops is not in sync (LOSW) or if a Margin alarm occurs.
AIS On SMJK/NREM	SAIS	ENA*	Causes the HRU to transmit the AIS signal towards the Customer Interface (CI) when in NREM or SmartJack loopback (see Figure 5).
		DIS	Causes the HRU to either transmit the signal from the network towards the CI RCU port or to open and terminate its RCV CI port when an HRU NREM or SmartJack loopback is executed. The AIS signal is not sent (towards the CI).
Margin Alarm Threshold	MARG	0 to 15 dB	The Margin Alarm Threshold can only be set via the RS-232 Craft port with a terminal. It determines the minimum allowable margin below which a system alarm can occur. Zero disables the alarm.
		4dB*	Default value

*Indicates factory default settings.

Table 9. HLU-431 List 1E System Settings Screen Options (Cont.)

System Settings Screen Options	Front Panel Display Code	Selection	Description
DSO Blocking	DS0	BLK	The DSO blocking option can only be set via the RS-232 Craft port with a terminal. The four-Character Line Unit front panel only displays the status of the blocking option. BLK indicates at least one channel is blocked.
		NONE*	Indicates no channels are blocked.

*Indicates factory default settings.

LOOPBACK MENU

The Loopback Menu permits you to issue loopbacks to the HiGain system. There are five possible Loopback Menus:

- Loopback Menu: No doubler
- Loopback Menu: One doubler
- Loopback Menu: Two doublers

In all instances, press **D** from the Maintenance Terminal Main Menu to display the Loopback Menu. [Figure 12](#) shows an example of a Loopback Menu when no doublers are present; [Figure 13](#) shows an example when four doublers are present.

Loopback Menu: No Doubler

[Figure 12](#) shows the Loopback Menu when no doublers are present.

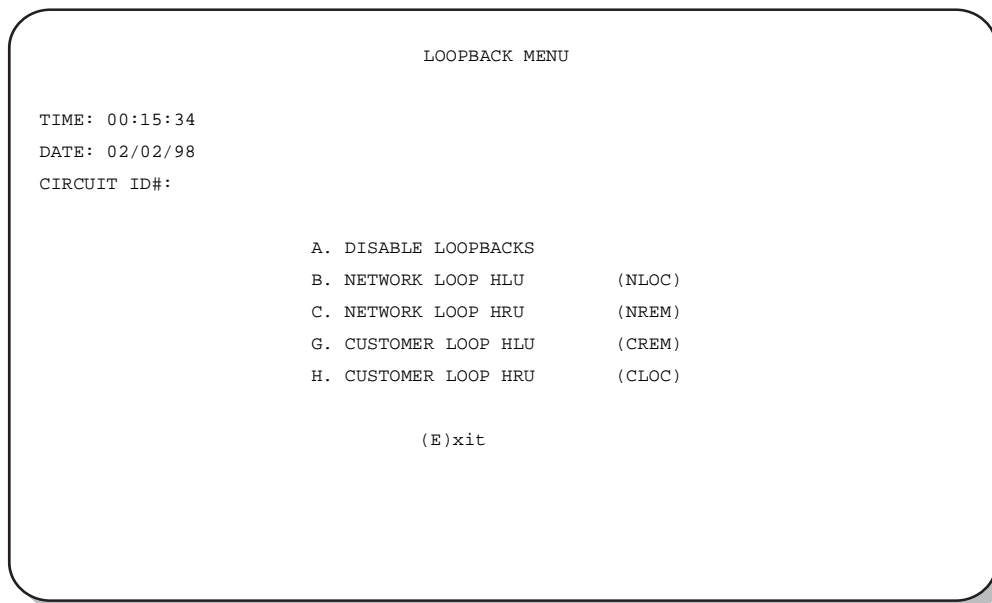

Figure 12. Loopback Menu: No Doubler

Loopback Menu: Two Doublers

Figure 13 shows the Loopback Menu with two doublers.

```

                                LOOPBACK MENU

TIME: 00:03:33
DATE: 02/02/98
CIRCUIT ID#:

A. DISABLE LOOPBACKS
B. NETWORK LOOP HLU          (NLOC)
C. NETWORK LOOP HRU          (NREM)
D. NETWORK LOOP DOUBLER 1    (NDU1)
F. NETWORK LOOP DOUBLER 2    (NDU2)
G. CUSTOMER LOOP HLU         (CREM)
H. CUSTOMER LOOP HRU         (CLOC)
I. CUSTOMER LOOP DOUBLER 1   (CDU1)
J. CUSTOMER LOOP DOUBLER 2   (CDU2)

                                (E)xit

```

Figure 13. Loopback Menu with Two Doublers

Initiating a Loopback

To send one of the available loopbacks, press the appropriate letter in the Loopback Menu. The following prompt appears:

```
PLEASE WAIT.....
```

A series of dots moves from left to right indicating that the command has been issued. When this process completes, the system returns to the Maintenance Terminal Main Menu. The selected loopback four letter designation now appears in the Loopback Mode field in the Maintenance Terminal Main Menu (see Figure 14 in which an NLOC loopback is in progress). The loopback continues to cycle in the system depending upon your Loopback Timeout setting.



The Loopback Menu screen is also available at the HRU connected to the HLU-431, thus allowing all HiGain System loopbacks to be initiated from either end of the circuit.

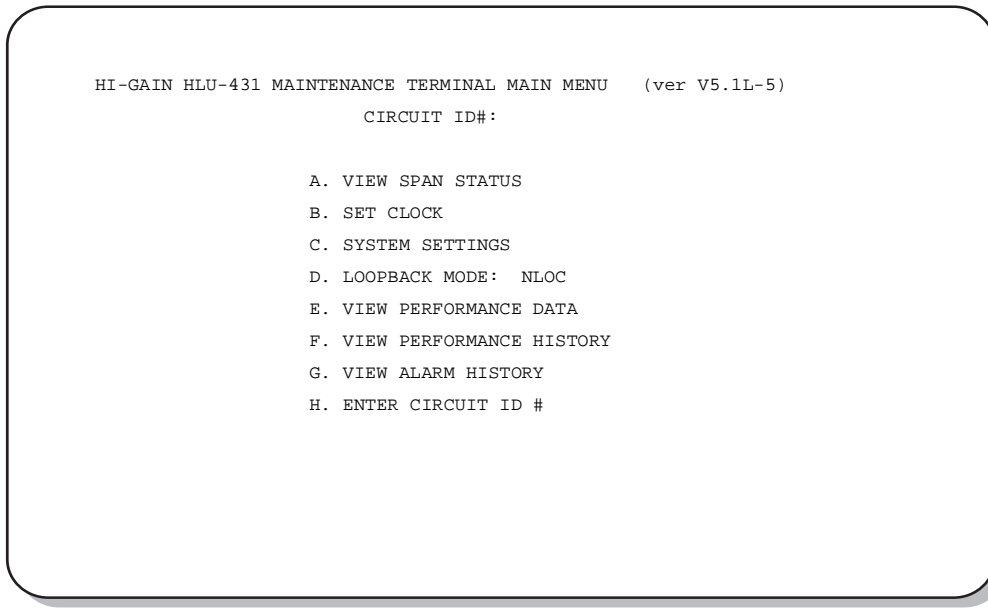

Figure 14. NLOC Loopback Mode in the Maintenance Terminal Main Menu

Disable Loopbacks

The Disable Loopbacks option allows you to disable (cancel) any of the loopbacks listed in the screen. To disable loopbacks, press **A** in the Loopback Menu. The following prompt appears:

PLEASE WAIT.....

A series of dots moves from left to right indicating that the command has been issued. When this process completes, the system returns to the Maintenance Terminal Main Menu in which the Loopback Mode will display as None.

PERFORMANCE DATA SCREENS

The Performance Data screens show the Errored (ES) and Unavailable Seconds (UAS) for both HDSL loops and each T1 input at 15-minute intervals over a 4-hour time interval. Earlier and later data, in 4-hour time periods on different span screens, can be accessed by pressing **P** (Previous) or **N** (Next) respectively. All Performance Data counters can be set to zero by pressing **C** (Clear) from the HLU-431 Span Status screen shown below.



Since the HLU-431 is considered the master module, this clears *all* performance data screens at both the HLU-431 and the HRU. The RS-232 interface at the HRU does not allow the counters to be cleared.

Errored and Unavailable seconds are defined in [Table 10](#).

Table 10. *Errored and Unavailable Seconds Definitions*

ES and UAS	Definition
HDSL Errored Second	A second in which at least one HDSL CRC has occurred.
HDSL Unavailable Second	A second in which an HDSL loop has sync loss at least once.
DS1 Errored Second	A second in which at least one BPV has occurred.
DS1 Unavailable Second	A second in which at least one T1 LOS condition (175 ± 75) zeros has occurred.

From each Performance Data screen you can do the following:

- Press **P** to view the previous 4-hour data screen.
- Press **N** to view the next 4-hour data screen.
- Press **E** to exit.
- Press **S** to view the next available span.

Performance Data Screen: No Doubler

Press **E** from the Maintenance Terminal Main Menu to view the Performance Data screen for applications ([Figure 15](#)) without a doubler. This screen shows the Errored and Unavailable Seconds for the HDSL span between the HLU-431 and the HRU.

```

Date: 02/02/98                PERFORMANCE DATA
CIRCUIT ID#:
                                ERRORED SECONDS/UNAVAILABLE SECONDS
                                DS1                HDSL-1                HDSL-2
                                HLU    HRU    HLU    HRU    HLU    HRU
20:30  000/000  000/000  000/000  000/000  000/000  000/000
20:45  000/000  000/000  000/000  000/000  000/000  000/000
21:00  000/000  000/000  000/000  000/000  000/000  000/000
21:15  000/000  000/000  000/000  000/000  000/000  000/000
21:30  000/000  000/000  000/000  000/000  000/000  000/000
21:45  000/000  000/000  000/000  000/000  000/000  000/000
22:00  000/000  000/000  000/000  000/000  000/000  000/000
22:15  000/000  000/000  000/000  000/000  000/000  000/000
22:30  000/000  000/000  000/000  000/000  000/000  000/000
22:45  000/000  000/000  000/000  000/000  000/000  000/000
23:00  000/000  000/000  000/000  000/000  000/000  000/000

```

Figure 15. *Performance Data Screen: No Doublers*

Performance Data Screen: With Doubler

The Performance Data Screen displays information by span. With no doubler, there is only one span (Figure 15). With multiple doublers (up to two), there can be as many as three span screens.

- 1 Press **E** from the Maintenance Terminal Main Menu to view the Performance Data screen.
- 2 Press **S** from the Performance Data screen to advance through the performance data screens for the various spans.

Figure 16 is an example of a Performance Data screen that lists performance data for the third span (Doubler #2 to the HRU).

Date: 02/02/98		SPAN 3 PERFORMANCE DATA					
CIRCUIT ID#:		ERRORED SECONDS/UNAVAILABLE SECONDS					
	DS1		HDSL-1		HDSL-2		
	HLU	HRU	HDU4	HRU	HDU4	HRU	
00:00	000/000	000/000	000/000	000/000	000/000	000/000	
00:15	000/000	000/000	000/000	000/000	000/000	000/000	
00:30	000/000	000/000	000/000	000/000	000/000	000/000	
00:45	000/000	000/000	000/000	000/000	000/000	000/000	
01:00	000/000	000/000	000/000	000/000	000/000	000/000	
01:15	000/000	000/000	000/000	000/000	000/000	000/000	
01:30	000/000	000/000	000/000	000/000	000/000	000/000	
01:45	000/000	000/000	000/000	000/000	000/000	000/000	
02:00	000/000	000/000	000/000	000/000	000/000	000/000	
02:15	000/000	000/000	000/000	000/000	000/000	000/000	
02:30	000/000	000/000	000/000	000/000	000/000	000/000	
02:45	000/000	000/000	000/000	000/000	000/000	000/000	
03:00	000/000	000/000	000/000	000/000	000/000	000/000	
03:15	000/000	000/000	000/000	000/000	000/000	000/000	
03:30	000/000	000/000	000/000	000/000	000/000	000/000	
03:45	000/000	000/000	000/000	000/000	000/000	000/000	

(E)xit (P)revious (N)ext (S)pan

Figure 16. Span 3 Performance Data Screen

VIEW PERFORMANCE HISTORY

The View Performance History option allows you to access the 7 Day History screens that show the number of ES and UAS occurrences in 24-hour increments for a seven-day period. Errored Seconds and Unavailable Seconds for both HDSL loops and each of the two DS1 inputs are listed for the current and previous seven days. The counters on all 7 Day History can be set to zero by pressing **C** (Clear).



Since the HLU-431 is considered the master module, this clears *all* performance data screens at both the HLU-431 and the HRU. The RS-232 terminal interface at the HRU does not allow the counters to be cleared.

The 7 Day History Screen: No Doubler

Press **F** (View Performance History) from the Maintenance Terminal Main Menu to open the 7 Day History screen for applications (Figure 17) without a doubler. The 7 Day History Span 1 screen shows the ES and UAS for the HDSL loop between the HLU-431 and the HRU.

```

Time: 00:16:55                                7 DAY HISTORY
CIRCUIT ID#:

                                SPAN 1
                                ERRORED SECONDS/UNAVAILABLE SECONDS

                                DS1                HDSL-1                HDSL-2
                                HLU        HRU        HLU        HRU        HLU        HRU
01/26  00000/00000  00000/00000  00000/00000  00000/00000  00000/00000  00000/00000
01/27  00000/00000  00000/00000  00000/00000  00000/00000  00000/00000  00000/00000
01/28  00000/00000  00000/00000  00000/00000  00000/00000  00000/00000  00000/00000
01/29  00000/00000  00000/00000  00000/00000  00000/00000  00000/00000  00000/00000
01/30  00000/00000  00000/00000  00000/00000  00000/00000  00000/00000  00000/00000
01/31  00000/00000  00000/00000  00000/00000  00000/00000  00000/00000  00000/00000
02/01  00000/00000  00000/00000  00000/00000  00000/00000  00000/00000  00000/00000
current 00000/00015  00004/00001  00002/00016  00005/00002  00004/00013  00007/00001

```

Figure 17. 7 Day History Screen for Span 1 (No Doubler)

The 7 Day History Screen: With Doubler

The 7 Day History screen displays information by span. With no doubler, there is only one span (Figure 17). With multiple doublers (up to two), there can be as many as three span screens.

- 1 Press **F** (View Performance History) from the Maintenance Terminal Main Menu to open the 7 Day History screen.
- 2 Press **S** from the 7 Day History screen to advance through the history screens for the various spans.

Figure 18 is an example of a 7 Day History screen that lists history data for the third span (Doubler #2 to the HRU).

```

Time: 03:09:34                7 DAY HISTORY
CIRCUIT ID#:

                                SPAN 5
                                ERRORED SECONDS/UNAVAILABLE SECONDS

                                DS1                HDSL-1                HDSL-2
                                HLU                HRU                HDU4                HRU                HDU4                HRU
04/09  00000/00000  00000/00000  00000/00000  00000/00000  00000/00000  00000/00000
04/10  00000/00000  00000/00000  00000/00000  00000/00000  00000/00000  00000/00000
04/11  00000/00000  00000/00000  00000/00000  00000/00000  00000/00000  00000/00000
04/12  00000/00000  00000/00000  00000/00000  00000/00000  00000/00000  00000/00000
04/13  00000/00000  00000/00000  00000/00000  00000/00000  00000/00000  00000/00000
04/14  00000/00000  00000/00000  00000/00000  00000/00000  00000/00000  00000/00000
04/15  00000/00000  00000/00000  00000/00000  00000/00000  00000/00000  00000/00000
current 00001/00000  01094/00798  00000/01101  00369/00004  00000/01101  00141/00006
    
```

Figure 18. 7 Day History Screen Span 3

VIEW ALARM HISTORY

The View Alarm History screen allows you to view alarms that are currently active. In the Alarm History screen the:

- First and Last columns contain the time and date stamp of the first and last occurrence of each alarm.
- Current column shows the status of each alarm.
- Count column lists the number of times each alarm occurred.
- maximum non-overflowing count is 999.

From each Alarm History screen you can do the following:

- Press **U** to update the screen.
- Press **S** to view another span.
- Press **C** to clear all data from the screen.
- Press **E** to exit from the Alarm History screen.

Table 11 lists the Alarm History fields and descriptions. These descriptions apply to the Alarm History for doubler applications as well.

Table 11. Alarm History Fields and Descriptions

Field	Description
Type	Identifies the type of alarm
LOS, DS1-HLU	First and last instance of LOS at the HLU DSX-1 input; Current condition, number of alarms
LOS, DS1-HRU	First and last instance of LOS at the HRU DS1 input; Current condition, number of alarms
Span 1 LOSW, HDL1	First and last instance of LOSW on HDL1; Current condition, number of alarms
Span 1 LOSW, HDL2	First and last instance of LOSW on HDL2; Current condition, number of alarms
Span 1 ES, HDL1	First and last instance of ES on HDL1; Current condition, number of alarms
Span 1 ES, HDL2	First and last instance of ES on HDL2; Current condition, number of alarms
Span 1 Margin L1	First and last instance of exceeded margin on Loop 1; Current condition, number of alarms
Span 1 Margin L2	First and last instance of exceeded margin on Loop 2; Current condition, number of alarms
PWR-OPEN	Power open condition; Current condition, number of alarms
PWR-SHRT	Power short condition; Current condition, number of alarms
Last Cleared: None	Last time Alarm History cleared; Current condition, number of alarms

Alarm History Screen: No Doubler

Press **G** from the Maintenance Terminal Main Menu to view the Alarm History screen for an application without a doubler (Figure 19).

```

ALARM HISTORY

TIME: 00:17:18
DATE: 02/02/98
CIRCUIT ID#:

Type           First           Last           Current           Count
LOS, DS1-HLU           OK              000
LOS, DS1-HRU           OK              000
SPAN1 LOSW, HDL1       OK              000
SPAN1 LOSW, HDL2       OK              000
SPAN1 ES, HDL1         OK              000
SPAN1 ES, HDL2         OK              000
SPAN1 MARGIN L1       OK              000
SPAN1 MARGIN L2       OK              000
PWR-OPEN              OK              000
PWR-SHRT              OK              000

LAST CLEARED: NONE

(E)xit (C)lear (U)pdate (S)pan

```

Figure 19. Alarm History Screen for Span 1

Alarm History Screen: With Doubler

The Alarm History screen displays information by span. With no doubler, there is only one span (Figure 19). With multiple doublers (up to two), there can be as many as three span screens.

- 1 Press **G** from the Maintenance Terminal Main Menu to view the Alarm History screen.
- 2 Press **S** from the Alarm History screen to advance through the alarm history screens for the various spans.

Figure 20 is an example of an Alarm History screen that lists history for the third span (Doubler #2 to the HRU).

```

ALARM HISTORY

TIME: 00:17:18
DATE: 02/02/98
CIRCUIT ID#:

Type           First           Last           Current       Count
LOS, DS1-HLU           OK             000
LOS, DS1-HRU           OK             000
SPAN3 LOSW, HDLSL1     OK             000
SPAN3 LOSW, HDLSL2     OK             000
SPAN3 ES, HDLSL1       OK             000
SPAN3 ES, HDLSL2       OK             000
SPAN3 MARGIN L1        OK             000
SPAN3 MARGIN L2        OK             000
PWR-OPEN              OK             000
PWR-SHRT               OK             000

LAST CLEARED: NONE

(E)xit (C)lear (U)pdate (S)pan

```

Figure 20. Alarm History Screen for Span 3

CIRCUIT ID

To set a Circuit ID:

- 1 Press **H** from the Maintenance Terminal Main Menu.
- 2 Type a unique identifier for the circuit, up to 24 characters, then press **ENTER**. If you type more than 24 characters, a warning beep sounds, and only the first 24 characters are accepted.
- 3 Choose **C** to confirm.

SYSTEM ALARMS

Table 12 lists possible HLU-431 alarm states. The accompanying front panel message is listed in the Alarm column. More than one alarm condition can exist at any given time, but only one message can be displayed. For multiple alarms, only the highest priority alarm displays.

Table 12. HDSL System Alarms

Front Panel Message	Alarm	Description	To Inhibit:
ALRM LOSW	Loss of Sync Word ^a	One of the HDSL loops has lost synchronization.	Cannot be inhibited.
ALRM LLOS	Local Loss of Signal	Loss of the DSX-1 input signal.	Cannot be inhibited.
ALRM RLOS	Remote Loss of Signal	Loss of the HRU DS1 input signal.	Disable the RDA (Remote DS1 Alarm) option. This prevents an LOS condition at the DS1 input to a HRU from activating Pin H. The front panel Status LED still flashes red and the ALRM RLOS message displays to alert you of the LOS state. LOS is sent towards the network from the HLU. This option prevents the common occurrences of a CPE LOS condition from generating recurring alarms and AIS payloads.
ALRM TLOS	Transmit Loss of Signal	The DS1 input is not present at the HRU. Places the HRU in loopback towards the network.	Set the TLOS switch at the HRU to disable.
ALRM H1ES or ALRM H2ES	Errored Second Rate exceeded	The number of errored seconds on HDSL Loop 1 or Loop 2 has exceeded the threshold value set by the terminal ES ALARM THRES option.	Set the Errored Second Threshold option to 0 (zero).
ALRM DS1	Bit Error Rate exceeded	The combined T1 and HDSL BER has exceeded you set threshold limits of 10^{-6} or 10^{-7} .	Select NONE for the BER system option.
ALRM MAL1 or ALRM MAL2	Margin Alarm Loop1 or Margin Alarm Loop2	The margin on HDSL Loop 1 or Loop 2 has dropped below the minimum threshold value set by the terminal MARGIN ALARM THRES option.	Set the Margin Alarm Threshold option to 0 (zero).

^a When both HDSL loops lose sync word (LOSW), a system alarm condition exists. However, since the HLU-431 enters a self test cycling mode, the front panel LED lights yellow instead of red and the `SELF TEST` message displays instead of the `ALRM` message.

RETIRING SYSTEM ALARMS

To retire a system alarm, press the SEL button and execute an Alarm Cut Off (ACO). An ACO turns the alarm off and replaces the ALRM message with an ACO message. The second part of the ALRM message, which defines the cause of the alarm, remains. Both parts of the message remain until the alarm condition clears or another higher priority alarm occurs.

SELF TEST

The Self Test mode that occurs when both HDSL loops are not in sync has been enhanced to include the input DS1 transceiver chip. The Self Test procedure can cause the AIS pattern that is normally transmitted from the HLU-431 during these out of sync intervals, to exhibit occasional BPVs.

LOOPBACK OPERATION

This section discusses loopback operations that are used to test the HiGain system.

SMARTJACK (SMJK) LOOPBACK

One of the most important loopback options is the SmartJack (SMJK) loopback, which enables an HRU response to the standard (2 and 3-in-5) SMJK in-band loopback codes in emulation of standard Network Interface Device (NID) functions. This option can be enabled or disabled from either the front panel MODE and SEL buttons or through the System Settings screen.

GENERIC LOOPBACK CODE (GNLB)

The HiGain generic loopback code is GNLB. The GNLB allows in-band codes to loop-up either the HLU/NLOC (4-in-7) or HRU/NREM (3-in-7) towards the network. In addition, it allows in-band codes to loop-up the HLU/CREM (6-in-7) or HRU/CLOC (5-in-7) towards the customer. Either loop-up condition is terminated (looped-down) with the 3-in-5, loop-down code. Both in-band codes must be present for 5 seconds before the HiGain system responds. See “GNLB Loopback Test Procedures” on page 41 for the test procedures that apply when using the GNLB mode.

The A1LB loopback selection, [Table 14](#), complies with that proposed for HDSL systems in the T1E1.4/92 recommendation with the following additions:

- Query loopback
- IOR (Intelligent Office Repeater) power-down
- Three loopback time-out choices
- Initiation from either end
- Repeating bit error signatures
- Alternate query loopback

These additions make A1LB identical to A2LB described in the next section. It is given a separate identity to allow future T1/E1 enhancements to be added without affecting A2LB.

ADDRESSABLE REPEATER LOOPBACK FUNCTIONS

In addition to the SMJK loopback, a HiGain system can be configured for one of five special in-band loopback (SPLB) command sequences. These are selected from the SPLB user option shown in [Table 9 on page 24](#) and [Figure 21 on page 39](#) (non-doubler applications). Doubler loopback locations are shown in [Figure 22 on page 40](#).

A2LB through A5LB are four special, addressable, repeater loopback functions which are supported by the HLU-431 List 1E. These loopbacks provide the HiGain system with sophisticated maintenance and trouble shooting tools. A2LB and A5LB are patterned after the Teltrend addressable T1 repeater loopbacks. A3LB and A4LB are patterned after the Wescom addressable T1 repeater loopbacks. All four SPLBs have been enhanced to handle the specific requirements of the following HiGain system customers:

- A2LB (Teltrend) = Southwestern Bell
- A3LB (Wescom) = New England Telephone
- A4LB (Wescom Mod 1) = New York Telephone
- A5LB (Teltrend Mod 1) = Southern New England Telephone (SNET)

A5LB differs from A2LB in that A5LB does not block the arming code from exiting the HLU-431 into the network. A2LB can be configured to either block this arming code after two seconds, and replace it with the AIS code, or to unblock it by executing the FAR-END ACTIVATE code. Since A5LB never blocks the arming code from exiting the Line Unit, it does not need this FAR-END ACTIVATE code. A3LB differs from A4LB in that A3LB supports the additional (1-in-6) SMJK loopback command.

A HiGain system may take longer than normal to respond to in-band loopback commands when its framing mode is set to UNFR and the in-band commands are set in either an SF or ESF mode. The frame bits override the command bits and cause errors in the command sequence. These errors cause the HiGain system to reject some sequences. This can extend the detection interval.

INITIATING MANUAL LOOPBACK SESSIONS

A manual loopback session allows you to select one of four HiGain system loopbacks.



Any of the HiGain loopbacks can be executed using the MODE and SEL buttons. In general, to execute a manual loopback session using the MODE and SEL buttons:

- **The next loopback option can be presented by pressing the MODE button, however, the previously executed loopback remains active until the SEL button is pressed and a different loopback is activated.**
- **If neither button is pressed for a period of 30 seconds and no loopback is in effect, the manual loopback session terminates and the normal margin displays reappear.**
- **If any loopback is in effect, the 30-second timeout is inhibited. The active loopback and the manual loopback session continue until the loopback times out in accordance with the LBTO setting.**
- **Only the SMJK loopback can exist with other networks at any given time.**
- **Pressing both buttons, again for 3 seconds, terminates any active loopback, ends the Manual loopback session and returns the display to normal mode.**

To initiate a manual loopback session:

- 1** Press both the MODE and SEL buttons on the front panel for at least 3 seconds. The following message appears on the front panel display:

MAN LPBK

followed by the message:

NLO?

- 2 Do one of the following:
 - To execute an NLOC loopback, press the SEL button. The message changes from NLO? to NLOC.
 - To execute an NREM loopback:
 - Press the MODE button. The message changes from NLO? to NRE?
 - Press the SEL button to execute the NREM loopback.
- 3 To execute a CRE loopback, press the MODE button again.
- 4 To execute a CLO loopback, press the MODE button a third time.

These same loopbacks can be initiated from the RS-232 Craft port by choosing the Loopback Mode, option D, from the Main Menu. This displays the Loopback Menu ([Figure 12 on page 26](#)) from which any of the loopbacks can be initiated or terminated.

All loopbacks, except the SMJK loopback, can be initiated by either in-band commands in the T1 payload or by a command from HiGain itself (front panel buttons or maintenance screen selections). Thus, whenever a loopback is active, the method by which it was activated is indicated in the Loopback and Status screens by inserting either HG (HiGain) or PL (Payload) adjacent to the identified loopback, for example NREM(HG).

LOOPBACK TEST PROCEDURES

The following sections provide step-by-step test procedures for the HLU-431 as a function of the loopback option selected. These procedures allow verification of the integrity of the HDSL channels at every module location as well as the DS1 channels to the customer and the local DSX-1 interface.

If trouble is encountered on the HLU-431 DSX-1 interface, verify that the HLU is making a positive connection with its mounting assembly (shelf) connector. Also, verify that the HLU internal equalizer is set to the correct distance range. All equalizers should be set to the distance from the DSX-1 to the shelf.

The transmit and receive T1 DSX-1 ports have splitting access jacks and miniature, 210-series, bridging jacks as shown in [Figure 1 on page 4](#). Connecting one cable between the two bridging jacks and another between the two SPAN jacks splits the XMT and RCV and creates metallic loopbacks towards both the DSX-1 and the HLU-431. If separate plugs are inserted into both SPAN jacks with the other end disconnected, the BRG jacks can be used to send and receive test patterns towards the DSX-1.

LOOPBACK OPERATION WITHOUT DOUBLERS

The complete family of loopbacks that a HiGain system can execute is shown in Figure 21. The loopbacks can be initiated from the HLU RS-232 Craft port, the HLU front-panel MODE and SEL buttons, or from a family of Special Loopback (SPLP) in-band loopback commands.

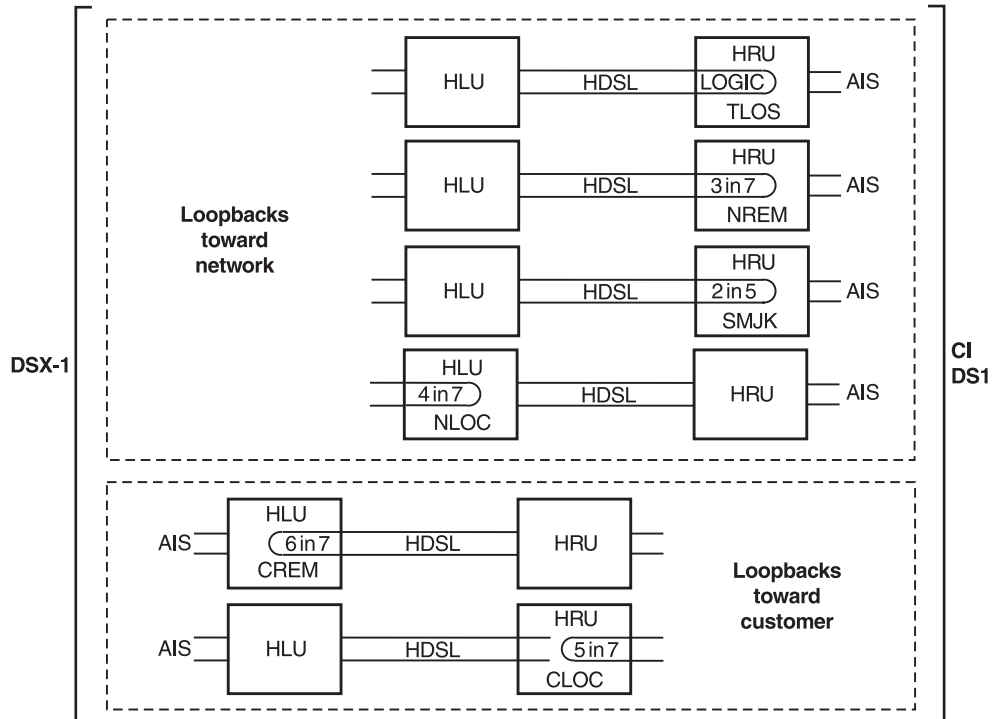
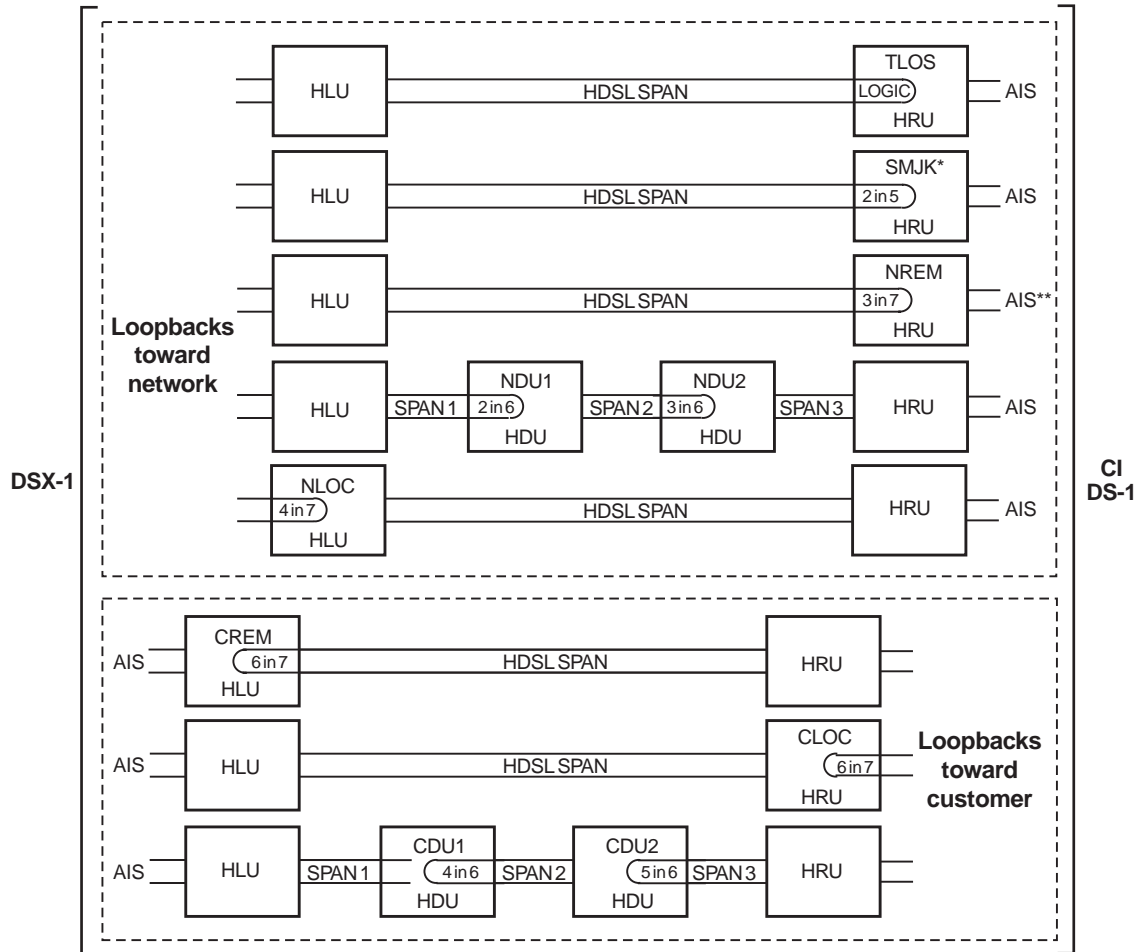

Figure 21. HLU-431 Non-Doubler Loopback Configurations

LOOPBACK OPERATION WITH DOUBLERS

The complete family of loopbacks that a HiGain system equipped with the HDU-409 can execute is shown in Figure 22. Four of those loopbacks, NDU1, NDU2; CDU1, CDU2 occur in the doubler. The loopbacks can be initiated from the HLU RS-232 Craft port, the HLU front-panel MODE and SEL buttons, or from a family of Special Loopback (SPLP) in-band loopback commands.



Use the 3 in 5 code to loop down any of these loopbacks.

* The Smart-Jack loopback is a metallic loopback in the HRU's Lists 6 and 7. It is a logic loopback in all lower HRU list numbers.

** The SAIS option must be set to ENA to cause the AIS pattern to be sent to the CI during Smart-Jack Loopback.

Figure 22. Doubler Loopback Configurations

The more common generic, SPLB in-band loopback commands for doubler loopbacks are listed in Table 13. The commands are very specific combinations of either 6 or 7 bits that continuously repeat. All NXXX loopbacks are towards the network. All CXXX loopbacks are towards the customer.

Table 13. *SPLB Loopback Command Set*

Loopback	Command
NDU1	1 1 0 0 0 0 (2-in-6)
NDU2	1 1 1 0 0 0 (3-in-6)
CDU1	1 1 1 1 0 0 (4-in-6)
CDU2	1 1 1 1 1 0 (5-in-6)

GNLB LOOPBACK TEST PROCEDURES

To perform the GNLB loopback test procedure:

- 1 Have the CO tester send the HRU (3-in-7) in-band loopup code for 5 seconds. You should be able to see that an HRU NREM loopback is in effect by observing the NREM message on the front panel display. (Loopback states are indicated by the green LOOP LED on the front panel and also display in the Span Status screen.)
- 2 Have the CO tester transmit a T1 test signal into the HLU-431 and verify that the returned (looped) signal is error-free.
- 3 If step 2 fails, have the CO tester transmit the (3-in-5) in-band loopdown code.
- 4 Have the CO tester send the HLU-431 (4-in-7) in-band loopup for 5 seconds. You should be able to see that an NLOC HLU-431 loopback is in effect. (Loopback states are indicated by the green LOOP LED on the front panel and also display in the Span Status screen.)
- 5 Repeat Step 2. If the test passes, the problem is in the downstream direction. If it fails, the problem is in the upstream direction.

Notes on Non-doubler GNLB Loopback Test Procedures:

- The HLU-431 can be looped up from the remote location (CREM) by issuing the (6-in-7) command at the HRU DS1 input port.
- The HRU can be looped up from the remote location (CLOC) by issuing the (5-in-7) command at the HRU DS1 input port.

Notes on Doubler GNLB Loopback Test Procedures:

- Doubler #1 can engage loopback from the remote location (CDU1) by issuing the (4-in-6) loopback command at the HRU DS1 input port.
- Doubler #1 can engage loopback from the local location (NDU1) by issuing the (2-in-6) loopback command at the HLU-431 DS1 input port.
- Doubler #2 can engage loopback from the remote location (CDU2) by issuing the (5-in-6) loopback command at the HRU DS1 input port.
- Doubler #2 can engage loopback from the local location (NDU2) by issuing the (3-in-6) loopback command at the HLU-431 DS1 input port.

A1LB, A2LB, and A5LB Test Procedures

To perform the HLU A1LB, A2LB, and the A5LB test procedures:

- 1 Send into the HLU-431 the in-band ARMING and NI LPBK code 11000 for at least 5 seconds.
- 2 Monitor the output of the HLU-431 for the return of the pattern. Return of the pattern indicates that:
 - either the HRU has looped up (if the SMJK Loopback option is Enabled),
 - or that an external NI has looped up (if the SMJK Loopback option is Disabled) and that the HLU-431 and HRU units have been ARMED.
- 3 Verify, if possible, that the HRU Loopback LED is either flashing, indicating that the HRU is armed, or lights steadily, indicating that it is both armed and in loopback.
- 4 Once armed, the HLU-431 can be looped back by sending Intelligent Office Repeater (IOR) LPBK activation code 1101 0011 1101 0011 (D3D3) for at least 5 seconds. The tester observes, the following activation response, in the order presented:
 - a 2 seconds of AIS (all ones pattern)
 - b 2 seconds of returning data pattern
 - c 231 logic errors (including the frame bit) occurring in the returned pattern comprising:
 - 10 errors, if ILR-1 (Doubler 1) was sent
 - 200 errors, if ILR-20 (Doubler 2) was sent
 - 20 errors, if ILR-2 (HRU) was sent
 - d normal looped data

This error pattern repeats every 20 seconds as long as the IOR loopback pattern is being sent. This also applies to ILR, Time-out Override, and Query commands.



Some Intelligent Repeater (IR) test sets do not count frame errors as bit errors when the test pattern is framed and the HLU-431 is set to the AUTO framing mode. To improve compatibility with those test sets, the HLU-431 generates 201 (NDU2) and 232 (NLOC) ID bit errors. As a result, the HLU-431 may indicate one more or one less bit error, depending on the test set type and the number of frame bits contained in the block of errored bits. To avoid this uncertainty, PairGain recommends sending the IR commands unframed.

The HLU is now in Logic Loopback. The Loopback Time-out option is user settable to:

- NONE (0 minutes)
- 20 minutes
- 60 minutes
- 120 minutes

These selections determine the duration of this loopback unless it is overridden by the Time-out Override command or a loop-down command is sent. If the Time-out Override code 1101 0101 1101 0110 (D5D6) is received, the activation sequence described in step 4, above, is repeated and the automatic timed expiration of the loopback is inhibited. If this Time-out Override is sent, then the only way to loop the HLU-431 down is to:

- issue the IR (Intelligent Repeater) LPDN (loop-down) code 1001 0011 1001 0011 (9393) *or*
- issue the NI LPDN and Disarm code 11100.

The automatic time-out timer is restored during subsequent loopback sessions.

5 Once the test is complete, do one of the following:

- If the system is to loopdown but remain ARMED, send the IR (Intelligent Repeater) LPDN code (universal loopdown).
- If all the equipment is to be looped down, disarmed and returned to normal operation, send the disarm code 11100.



The ARMED mode has an automatic time-out of 120 minutes but this timer is reset to 120 for any of the following events:

- **Loopback terminates (manually or time-out),**
- **Query**
- **Alternate query**
- **Far end activate**
- **Another ARM command.**

Using the codes listed in [Table 14 on page 44](#), a network tester can activate loopbacks NLOC or NREM or SMJK (if enabled). A customer tester can activate loopbacks CLOC or CREM. All loopbacks shown in [Table 14](#) can also be initiated from the HLU-431 front panel MODE and SEL buttons (see [“Setting Options through SEL and MODE” on page 10](#)).



Information specific to HiGain doublers is shown in bold in [Table 14](#).

Table 14. Addressable 1, 2, 5 (A1LB, A2LB, A5LB) Repeater Loopback Commands

Name	Description	Code ^a
ARMING or NI LPBK (in-band)	Arming code	11000 11000 ...
ARMING or NI LPBK (ESF Data Link)	Arming code	1111(F) ^b 1111(F)0100(4)1000(8)
IR LPDN or DISARM (in-band)	Disarming code	11100 11100 ...
DISARM (ESF Data Link)	Disarming code	1111(F)1111(F)0010(2)0100(4)
IOR LPBK (NLOC and CREM 229-231 bit errors) ^c	HLU Loopup	1101(D)0011(3)1101(D)0011(3)
ILR-1 LPBK (NDU1 and CDU1 10 bit errors) ^d	DOUBLER-1 Loop up	1100(C)0111(7)0100(4)0001(1)
LR-20 LPBK (NDU2 and CDU2 200 bit errors)	DOUBLER-2 Loop up	1100(C)0111(7)0101(5)0100(4)
ILR-2 LPBK (NREM and CLOC 20 bit errors)	HRU Loop up	1100(C)0111(7)0100(4)0010(2)
IR LPDN	Loopdown (HLU or HRU)	1001(9)0011(3)1001(9)0011(3)
IR QUERY LPBK	Query loopback	1101(D)0101(5)1101(D)0101(5)
IR ALTERNATE QUERY LPBK	Alternate Query loopback	1101(D)0101(5)1110(E)1010(A)
TIME-OUT OVERRIDE	Loopback Time-out Override	1101(D)0101(5)1101(D)0110(6)
FAR END NI ACTIVATE ^e	Unblock AIS and pass 2-in-5	1100(C)0101(5)0101(5)0100(4)
IOR POWER DOWN (HLU)	Removes HDSL line power	0110(6)0111(7)0110(6)0111(7)

a The left most bit arrives first in all sequences. The detection algorithm functions reliably with a random 10^{-3} Bit Error Ratio (BER) on the facility. The IOR POWER DOWN code must remain present for the duration of the power down mode. When this code is removed, the HiGain system returns to its normal unlooped and unarmed state. Note that the entire arming and loopback sequence can be initiated at the remote HRU location.

b This is the HEX number for the 4-bit group.

c The HRU identifies CREM with 231 bit errors, including the frame bits. When framed data is being sent in the AUTO framing mode, the number of the 231 bit errors detected by the test set varies from 229 to 231, depending on whether or not the test set counts frame errors as bit errors, and on the number of frame bits contained in the block of 231 error bits.

d The HRU generates this bit pattern in a series of discontinuous bursts containing 20-bit errors each, including frame bits. Those test sets that do not count frame error bits as data bit errors will indicate fewer bits than the HRU transmits for this CI loopback.

e Not supported by A5LB.

A3LB and A4LB Test Procedures

The HLU-431 can be looped back by sending the Addressable Office Repeater (AOR) LPBK activation code 1111(F) 1111(F) 0001(1) 1110(E) for at least 5 seconds. This causes the HLU-431 to enter the NLOC state. The Loopback Time-out option can be set by the user to:

- NONE (0 minutes)
- 20 minutes
- 60 minutes
- 120 minutes

These selections determine the duration of this loopback, unless it is overridden by the reception of a second identical 16-bit loop-up command before the timer expires. When this time-out override state exists, the only way to loop the HLU-431 down is to issue one of the three loopdown commands listed in Step 2. The automatic time-out mode is restored during subsequent loopback sessions.

Table 15 summarizes the codes required to execute Addressable 3 and 4 (A3LB and A4LB) repeater loopback commands. All code sequences must be present for at least 5 seconds. The abbreviations used in Table 15 are as follows:

- LU = LoopUp
- LD = LoopDown
- NI = Network Interface
- CI = Customer Interface
- ESF-DL = Extended Super Frame Data Link



Information specific to HiGain doublers is shown in bold in Table 15.

Table 15. Addressable 3 and 4 (A3LB and A4LB) Repeater Loopback Commands

Position	Name	Code ^a
HLU-431 LU FROM NI	NLOC	1111(F) ^b 1111(F)0001(1)1110(E)
HLU-431 LU from CI	CREM	0011(3)1111(F)0001(1)1110(E)
HDU DOUBLER 1 FROM NI	NDU1	1111(F)1111(F)0000(0)1000(4)
HDU DOUBLER 1 FROM CI	CDU1	0011(3)1111(F)0000(0)0100(4)
HDU DOUBLER 2 FROM NI	NDU2	1111(F)1111(F)0000(0)0110(6)
HDU DOUBLER 2 FROM CI	CDU2	0011(3)1111(F)0000(0)0110(6)
HRU LU FROM NI	NREM	1111(F)1111(F)0000(0)0010(2)
HRU LU FROM CI	CLOC	0011(3)1111(F)0000(0)0010(2)
HRU LU FROM NI	SMJK	1100 1100 1100 ...
HRU LU FROM NI (ESF-DL)	SMJK	1111(F)1111(F)0100(4)1000(8)
HLU and HRU LD FROM NI OR CI	Loopdown	11100 11100 11100 ...
HLU and HRU LD FROM NI OR CI	Loopdown	100 100 100 ...
HLU and HRU LD FROM NI OR CI (ESF-DL)	Loopdown	1111(F)1111(F)0010(2)0100(4)

^a The left-most bit arrives first in all sequences. The detection algorithm functions reliably with a random 10^{-3} Bit Error Ratio (BER) on the facility. The entire arming and loopback sequence can be initiated at the remote HRU location.

^b This is the HEX number for the 4-bit group.

APPENDIX A - TECHNICAL SPECIFICATIONS

HDSL Line Code	784 kbps 2B1Q.
HDSL Output	+13.5 dBm \pm 0.5 dB at 135 ohms.
HDSL Line Impedance	135 ohms.
Maximum Provisioning Loss	35 dB at 196 kHz, 135 ohms.
Line Clock rate	Internal "Stratum 4" clock.
HDSL Start-up Time	30 seconds (typical), 60 seconds (maximum) per span.
One-way DS1 Delay	<220 microseconds per span.
DSX-1 Line Impedance	100 ohms.
DSX-1 Pulse Output	12 V _{pk-pk} for EXTERNAL equalizer or pre-equalized for 0-655 feet of ABAM-specification cable.
DSX-1 Input Level	+1.5 to -7.5 dBDSX.
DS1 Line Rate	1.544 Mbps \pm 200 bps.
DS1 Line Format	AMI, B8ZS or ZBTSL.
DS1 Frame Format	ESF, SF or UNFR.
Maximum Power Consumption	18 Watts (without Doubler); 35 Watts (with Doubler).
Maximum Heat Dissipation	8 Watts (without Doubler); 12.5 Watts (with Doubler).
Fusing	Internal; connected to "FUSE-ALARM" output on pin 32.
HDSL Span Voltage	-140 to \pm 100 VDC.
Margin Indicator	Displays HDSL span SNR margin for both HDSL spans relative to 10 ⁻⁷ BER operation.
Electrical Protection	Secondary surge protection on DS1 & HDSL ports. Power cross protection on HDSL ports.
Operating Temperature and Humidity	-40° to +65° Celsius, 5 to 95% (non-condensing)
Mounting	AT&T 220-configuration or equivalent.
Dimensions	Height: 5.6" (14 cm) Width: 1.4" (3.5 cm) Depth: 5.6" (14 cm) Weight 1 lb. 2 oz.

APPENDIX B - ABBREVIATIONS

2B1Q	2 Binary, 1 Quaternary
AIS	Alarm Indicator Signal
AMI	Alternate Mark Inversion
B8ZS	Bipolar with 8-zero Substitution
BPV	Bipolar Violation
CI	Customer Installation
CO	Central Office
CLOC	Customer Local Loopback
CPE	Customer Premises Equipment
CRC	Cyclic Redundancy Check
CREM	Customer Remote Loopback
CSA	Carrier Service Area
CSU	Channel Service Unit
DCE	Data Circuit-Terminating Equipment
DDS	Digital Data Service
DL	Data Link
DS1	Digital Signal, Level 1
DSX-1	DS1 Cross-connect Frame
ES	Errored Seconds
ESF	Extended SuperFrame
ESF DL	Extended SuperFrame Data Link
HCDS	High Capacity Digital Service
HDSL	High-bit-rate Digital Subscriber Lines
HDU	HiGain Doubler Unit
HLU	HiGain Line Unit
HRE	HiGain Remote Enclosure
HRU	HiGain Remote Unit
I-CPE	Interface-Customer Premises Equipment
LOS	Loss of Signal

LOSW	Loss of Sync Word
NEBS	Network Equipment Building System
NI	Network Interface
NID	Network Interface Device
NIU	Network Interface Unit
NLOC	Network Local Loopback
NMA	Network Management and Administration
NREM	Network Remote Loopback
POTS	Plain Old Telephone Service
SAIS	SmartJack AIS
SF	Super Frame
SNR	Signal-to-Noise Ratio
SPLB	Special Loopback
STS	Span Terminating Shelf
TLOS-LB	Transmit Loss of Signal-Loopback
TSGR	Transport System Generic Requirements
UAS	Unavailable Seconds
UL	Underwriters Laboratory
ZBTSI	Zero-Byte Timeslot Interchange

APPENDIX C - FUNCTIONAL OPERATION

PairGain HDSL technology provides full-duplex services at standard T1 rates over copper wires between an HLU and an HRU, which comprise one HiGain system. HiGain systems use PairGain 2-Binary 1, Quaternary (2B1Q) HDSL transceiver systems to establish two, full-duplex, 784 kbps data channels between the HLU-431 and a remotely located HDU or HRU. This provides a total capacity of 1.568 Mbps between the two units.

A block diagram of the HLU-431 is shown in Figure 23. The HLU-431 receives a 1.544 Mbps DSX-1 data stream from the DSX-1 digital cross connect interface. The HLU-431 contains a DS1 frame synchronizer controlled by an 8-bit microprocessor that determines the type of framing on the DS1 stream and synchronizes to it. The HLU-431 recognizes Super Frame (SF), including D4, or Extended Super Frame (ESF) framing. When the data is unframed, the HLU-431 arbitrarily defines a frame bit.

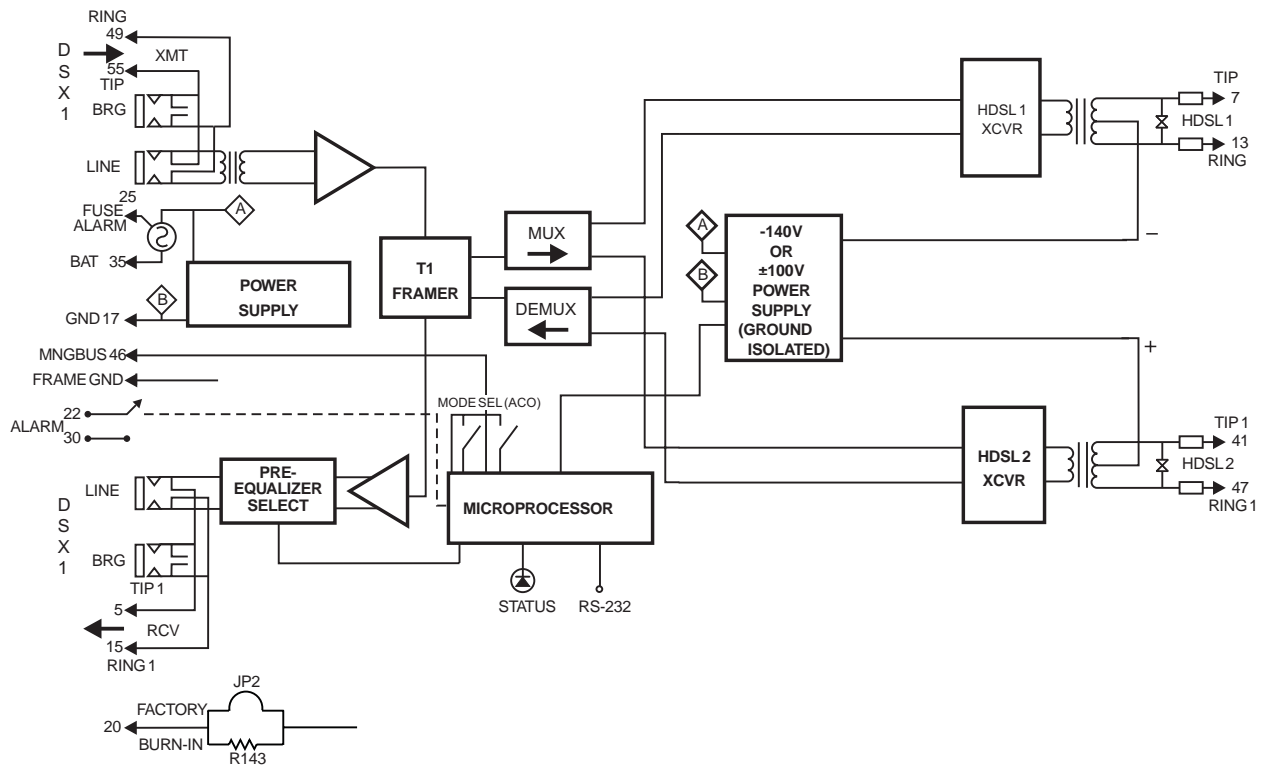

Figure 23. HLU-431 Block Diagram

POWER CONSUMPTION WITHOUT DOUBLERS

The three most important power parameters of an HLU are its maximum power consumption, its maximum power dissipation, and its maximum current drain.

The Maximum Power Consumption is the total power that the HLU-431 consumes or draws from its -48 V shelf power source. This parameter is needed when the HLU-431 is remotely located to its serving CO. It determines the battery capacity required to maintain an eight-hour standby battery reserve for emergency situations; thus limiting the maximum number of plugs per line unit's remote enclosure.

The Maximum Current Drain is the maximum current drawn from the shelf power supply when it is at its minimum voltage (-42.5 V). It determines the shelf fusing requirements.

Heat baffles should be placed between every other shelf, in racks containing more than two shelves. This technique deflects the rack's heat outward and reduces thermal stress on the plugs.

Power Consumption: Without Doublers

Maximum Power Dissipation:

- Per Slot = 6 Watts
- Per Shelf = 84 Watts (14 slots)

Maximum Power Consumption:

- Per Slot = 14 Watts
- Per Shelf = 196 Watts

Maximum Current Drain:

- Per Slot = 0.38 Amps
- Per Shelf = 5.3 Amps



The worst case conditions, under which these parameters were measured, include a 9,000 ft., AWG 26 loop, 60 mA of Customer Provided Equipment (CPE) current, a fully loaded 14-slot shelf, and a -42.5 V shelf battery voltage with the HLU-431 4-character display "OFF."

Power Consumption: With Doublers

For doubler applications, one or two doublers may be used in the HDSL loops between the HLU-431 List 1E and an HRU. The HLU-431 can line power two doublers and the remote unit (three spans) for circuits up to 2000 ohms of loop resistance. This feature is only available when using the HDU-439, 437, List 1 “mini” doublers and the HRU-412 List 8 or HRU-402 remote unit in HDU-431 List 1E circuits. It is also available when using configurations 22 or greater of the HRU-410 List 6 and configurations 16 or greater of the HRU-412 List 7. The HLU-431 List 1E can line power up to three full CSA spans when using HDU-404, 407, or 409 doublers. See [Table 17](#) for doubler deployment guidelines.

For additional information on the “mini” doublers, refer to technical practice 150-439-100-01. This section covers HLU-431 List 1E operation with the HDU-451 List 1, 2, 3, and 4, or the HDU-439, 437 “mini” doublers or the HDU-404, 407, or 409 “micro” doublers. The List 1 and 2 doublers have identical power consumption factors. The List 3 and 4 units are low power doublers and consume 40% less power than the List 1 and 2.

The maximum current drain is the current drawn from the shelf power supply when it is at minimum voltage (-42.5 Vdc) under a worst case application. The worst case application for the HLU-431 List 1E occurs on a loop with one HDU doubler, four 9000 feet of #26 AWG spans, and an HRU-412 that is providing 60 mA of CPE current. Under these conditions, the HLU-431 current drain from the -42.5 Vdc battery is 0.8 A for the List 1 and 2, and 0.55 A for the List 3 and 4 doublers. This CO current and other related power parameters for this doubler application are listed in [Table 16](#). The worst case loop conditions assumed for the three-span line powering applications listed in [Table 16](#) are a 2000 ohm total loop consisting of 9000 feet of #26 AWG for spans 1 and 2, and 6000 feet of #26 AWG for span 3.



In [Table 16](#), M/M refers to the HDU-437 and HDU-439 mini doublers and the HDU-404, HDU-407, and HDU-409 micro doublers.

Table 16. HLU-431 List 1E Power Parameters with HDU Doublers, List 1, 2, 3, & 4, and M/M

60 mA CPE Current	CO Voltage Volts	CO Current Amps List 1, 2	CO Current Amps List 3, 4	CO Current Amps 3 span line Powering	Power Consump. Watts List 1, 2	Power Consump. Watts List 3, 4 M/M	Power Consump. Watts 3 span line Powering	HLU Power Dissipation Watts List 1, 2	HLU Power Dissipation Watts List 3, 4 M/M	HLU Power Dissipation Watts 3 Span Line Powering
OFF	42.5	0.65	0.46	0.8	28	20	34	6.5	6.5	9.0
OFF	48.0	0.59	0.41	0.7	28	20	34	6.5	6.5	9.0
OFF	56.0	0.50	0.35	0.6	28	20	34	6.5	6.5	9.0
ON	42.5	0.80	0.55	n/a	34	23.5	n/a	6.75	6.75	n/a
ON	48.0	0.70	0.48	n/a	34	23.5	n/a	6.75	6.75	n/a
ON	56.0	0.60	0.43	n/a	34	23.5	n/a	6.75	6.75	n/a

The thermal loading limitations imposed when using the HLU-431 List 1E in Controlled Environmental Vaults (CEV) or other enclosures are determined by applying the HLU-431 List 1E power parameters to the manufacturer requirements for each specific housing.

The power consumption listed in [Table 12](#) is the total power that the HLU-431 List 1E consumes or draws from its -48 VDC shelf power source. This parameter is needed when the HLU-431 List 1E is located remote to its serving CO. It determines the battery capacity required to maintain an 8-hour stand-by battery reserve for emergency situations. It thus limits the maximum number of plugs per remote enclosure. Use this data to perform this analysis on a case by case basis.

APPENDIX D - COMPATIBILITY

MOUNTING

The HLU-431 List 1E is compatible any mounting that accepts 400 mechanics including the following PairGain mountings:

- HRE-420, Single Slot
- HRE-422, Dual Slot
- HRE-427, Seven Slot
- HRE-450, Single Slot Outdoor
- HRE-454, Four Slot Outdoor

HIGAIN DOUBLER CIRCUIT DEPLOYMENT

All generations of HiGain HLU and HRU modules are compatible with each other. Although all HiGain doublers are backward-compatible with all prior HLU and HRU models, some of the circuit application enhancements of newer doubler models require that all circuit modules be of the same vintage in order to realize these enhancements. Enhanced doubler applications preclude the mixing of newer doubler models with older models of the HRU and HLU.

[Table 17 on page 53](#) provides a matrix of HiGain doubler deployment rules to achieve maximum circuit enhancement. It lists:

- Maximum number of doublers allowed for a given circuit, depending upon the doubler and line unit models used to implement the circuit.
- Any restrictions on the HRU models.



All spans are fully CSA-compliant unless otherwise specified. Circuits that use more than one type of doubler are governed by the most limiting doubler rules. For example, if the HDU-451 is used with the HDU-409, use the HDU-451 deployment rules.

Table 17. HiGain Doubler Deployment Matrix

HLU Model	Maximum Number of Doublers Per Circuit ^a											
	HDU-451, List 3, 3B, 4, 4B				HDU-437, 439				HDU-404, 407, 409			
	Line Powered		Local Powered		Line Powered		Local Powered		Line Powered		Local Powered	
	CPEI ON	CPEI OFF	CPEI ON	CPEI OFF	CPEI ON	CPEI OFF	CPEI ON	CPEI OFF	CPEI ON	CPEI OFF	CPEI ON	CPEI OFF
HLU-231 List 6X; HLU-232 List 1D	1	1	2	2	1	1	2	2	1	2	2	2
HLU-319 List 2X; HLU-388 List 2X	1	1	2	2	1	1	2	2	1	2	2	2
HLU-231, List 7X; HLU-431, List 1D and 1E	1	1	2	2	1	2 ^b	2	2	1	2	2	2
HLU-231, List 8X; HLU-319, List 5X; HLU-388 List 5X	1	2 ^c	2	2	1	2	2	2	2	3 ^c	2	4 ^d

a HRU-411 applications with CPEI are limited to single doubler circuits (HDU-404, HDU-407 or HDU-409). The HRU-412, HDU-451, HDU-437 and HDU-439 are limited to applications with one and two doublers only.

b 2000 ohm maximum loop resistance. Requires HRU-412 List 7A or 8A, or HUR-402 or HUR 411.

c Requires HRU-402 or 411.

d Requires HRU-402.

APPENDIX E - PRODUCT SUPPORT

This section contains product support and warranty information.

TECHNICAL SUPPORT

PairGain Technical Assistance is available 24 hours a day, 7 days a week by contacting PairGain Customer Service Engineering group at:

Telephone: (800) 638-0031 or (714) 832-9922

Fax: (714) 832-9924

During normal business hours (8:00 AM to 5:00 PM, Pacific Time, Monday through Friday, excluding holidays), technical assistance calls are normally answered directly by a Customer Service Engineer. At other times, a request for technical assistance is handled by an on-duty Customer Service Engineer through a callback process. This process normally results in a callback within 30 minutes of initiating the request.

In addition, PairGain maintains a computer bulletin board system for obtaining current information on PairGain products, product troubleshooting tips and aids, accessing helpful utilities, and for posting requests or questions. This system is available 24-hours a day by calling (714) 730-2800. Transmission speeds up to 28.8 kbps are supported with a character format of 8-N-1.

WARRANTY

PairGain Technologies warrants this product to be free of defects and to be fully functional for a period of 60 months from the date of original shipment, given correct customer installation and regular maintenance. PairGain will repair or replace any unit without cost during this period if the unit is found to be defective for any reason other than abuse or incorrect use or installation.

Do not try to repair the unit. If it fails, replace it with another unit and return the faulty unit to PairGain for repair. Any modifications of the unit by anyone other than an authorized PairGain representative voids the warranty.

If a unit needs repair, call PairGain for a Return Material Authorization (RMA) number and return the defective unit, freight prepaid, along with a brief description of the problem, to:

PairGain Technologies, Inc.
14352 Franklin Avenue
Tustin, CA 92780
ATTN: Repair and Return Dept.
(800) 638-0031

PairGain continues to repair faulty modules beyond the warranty program at a nominal charge. Contact your PairGain sales representative for details and pricing.

FCC COMPLIANCE

This unit complies with the limits for Class A digital devices pursuant to Part 15 of the FCC rules. These limits are designed to provide reasonable protection against harmful interference when the equipment is operated in a commercial environment. This equipment generates, uses, and can radiate radio frequency energy and, if not installed and used in accordance with the instruction manual, can cause harmful interference to radio communications. Operation of this equipment in a residential area is likely to cause harmful interference, in which case the user will be required to correct the interference at his own expense.

Refer to the installation section of the appropriate instruction manual for the unit you are installing to get information on:

- Cabling
- Correct connections
- Grounding

MODIFICATIONS

The FCC requires the user to be notified that any changes or modifications made to this device that are not expressly approved by PairGain Technologies, Inc. may void the user's authority to operate the equipment.

All wiring external to the products should follow the provisions of the current edition of the National Electrical Code.

STANDARDS COMPLIANCE

The HLU-431 List 1E has been tested and verified to comply with the applicable sections of the following standards.

- GR-63-CORE - Network Equipment-Building System (NEBS) Requirements
- GR-089-CORE - Electromagnetic Compatibility and Electrical Safety

To comply with the intrabuilding wiring requirements of GR-1089-CORE, section 4.5.9, the shields of the ABAM-type cables that connect the HLU-431 List 1E DSX-1 output ports to the cross-connect panel must be grounded at both ends.

BARCODE AND CONFIGURATION NUMBER INFORMATION

Figure 24 shows the location of the P1 barcode and configuration number label on the HLU-431 List 1E. Table 18 gives a brief description of what each label contains.

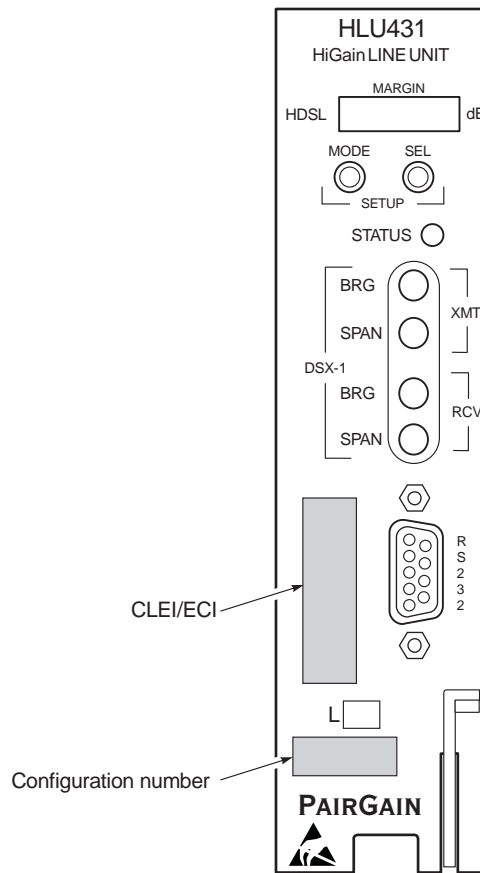

Figure 24. Bar Code Label and Configuration Number

Table 18. Bar Code Label and Configuration Number Descriptions

Number	Components
CLEI/ECI bar code label	Contains the serial number and part number of the unit, as indicated in both bar code and text format. Also contains the configuration number of the unit as indicated by "CFG:nn," where <i>nn</i> is the configuration number. For example, CFG:07 indicates a revision number 7.
Configuration number	The configuration number is a two or three-digit number that is either the last digits of a five or six-digit warranty control number or a standalone configuration number of two or three digits.

Corporate Office

14402 Franklin Avenue

Tustin, CA 92780

Tel: (714) 832-9922

Fax: (714) 832-9924

For Technical Assistance:

(800) 638-0031

