

HiGAIN LINE UNIT

QUICK INSTALLATION GUIDE

Model	List	Part Number	CLEI Code
HLU-431	1D	150-1504-14	T1L2FKDAAA

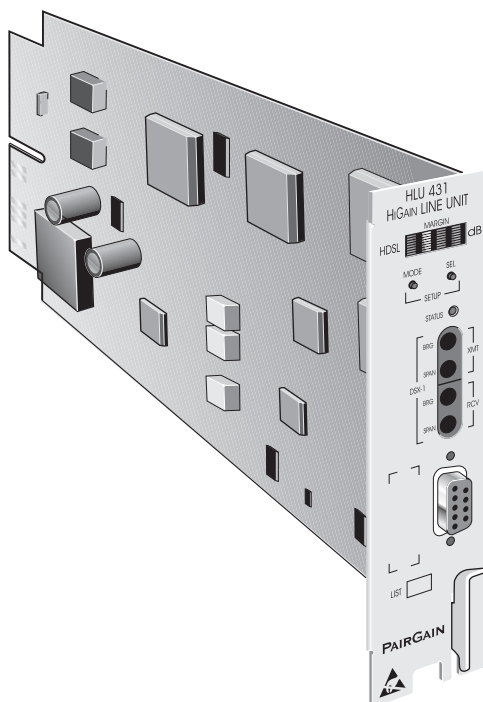

PAIRGAIN TECHNOLOGIES, INC.

SECTION 350-431-114-01

Revision history of this guide.

Revision 01—January 27, 1998

A) Initial Release

Table of Contents

Introduction	1
Compatibility	2
Installation	3
Card-Edge Connectors	4
Installing the Line Unit	5
HDSL Line Voltage Option.....	6
Provisioning	6
Using the SEL and Mode Front Panel Buttons	6
Default Settings	7
Using the Craft port	7
System Options Settings	8
Testing.....	11
Alarms	11
Loopbacks	12
Four-Character Diagnostic Messages	14
Specifications	16
Documentation	16
Technical Support	16
Bulletin Board Services	17

Copyright ©1998 PairGain Technologies, Inc.

PairGain and HiGain are registered trademarks of PairGain Technologies, Inc.

Information contained in this document is company private to PairGain Technologies, Inc. and shall not be modified, used, copied, reproduced or disclosed in whole or in part without the written consent of PairGain.

Other product names mentioned in this practice are used for identification purposes only and may be trademarks or registered trademarks of their respective companies.

Introduction

The PairGain® HiGain® Line Unit Model HLU-431 List 1D (Part Number 150-1504-14) is the Central Office (CO) side of a repeaterless T1 transmission system and is used in conjunction with the HRU Remote Unit to provide a complete HiGain High-bit-rate Digital Subscriber Line (HDSL) system.

This guide addresses HLU-431 List 1D operation when used with and without doublers. For applications without doublers, the HLU-431 List 1D is directly connected to the HRU by the two cable pairs. For doubler applications, one or two doublers may be used in the HDSL loops between the HLU-431 List 1D and the HRU.

The following figure shows the front panel of the HLU-431 Line Unit List 1D.

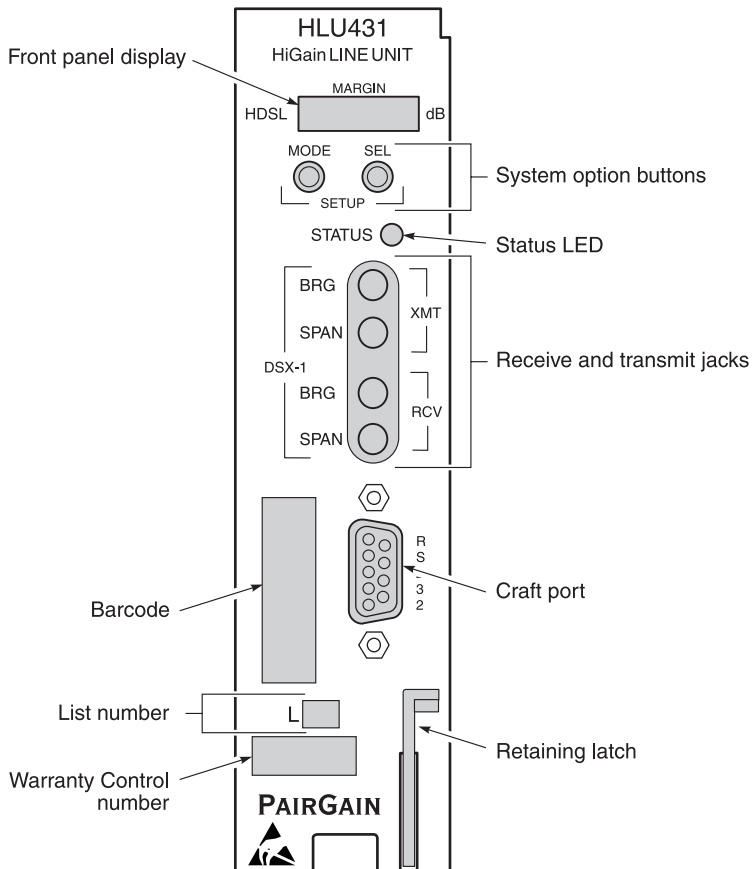

The HLU-431 List 1D front panel tri-color Status LED has the following states:

Status LED States

State	Description
Green	Normal Operation.
Flashing Green	HDSL Acquisition.
Flashing Red	Minor Alarm.
Red	FUSE ALRM.
Yellow	Self Test in progress or an HLU-431 List 1D loopback in effect (CREM) or (NLOC).
Flashing Yellow	The HLU-431 List 1D is in an ARMED (pre-loopback) state.

Compatibility

The HLU-431 mounts in the [PairGain](#) shelves listed below. The HLU-431 slot pins are shown in the *Card-Edge Connectors* on page 4.

- [HRE-420, Single Slot](#)
- [HRE-422, Dual Slot](#)
- [HRE-427, Seven Slot](#)
- [HRE-450, Single Slot Outdoor](#)
- [HRE-454, Four Slot Outdoor](#)

Installation

Upon receipt of the equipment, visually inspect it for signs of damage. If the equipment has been damaged in transit, immediately report the extent of damage to the transportation company and to PairGain Technologies (see *Technical Support* on page 16).

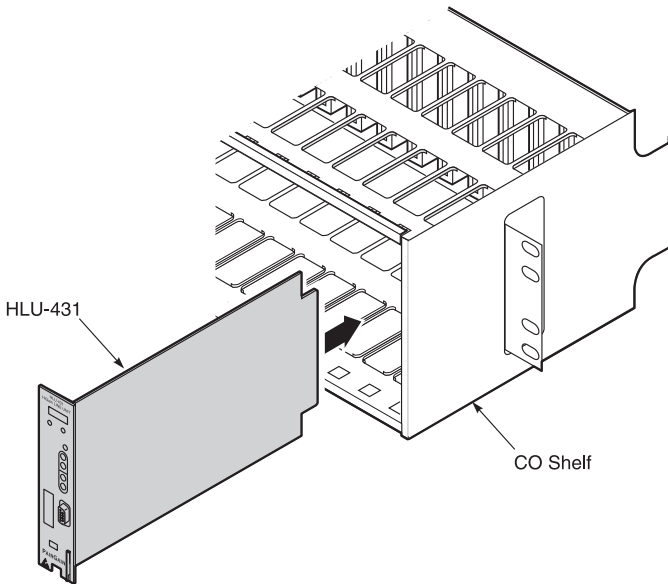

Card-Edge Connectors

The HLU-431 card-edge connector pinouts are shown below.

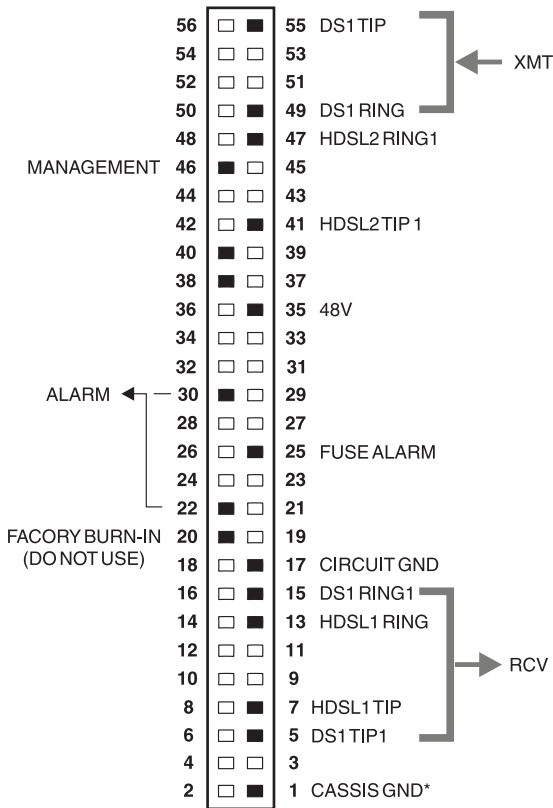

* Chassis GND may be tied to earth GND per local practice.

Installing the Line Unit

To install the HLU-431 into a shelf, slide the unit into the shelf card guides for the desired slot, then push the unit in until it is entirely within the card guide and the retaining latch locks into place, indicating that the unit is properly seated:

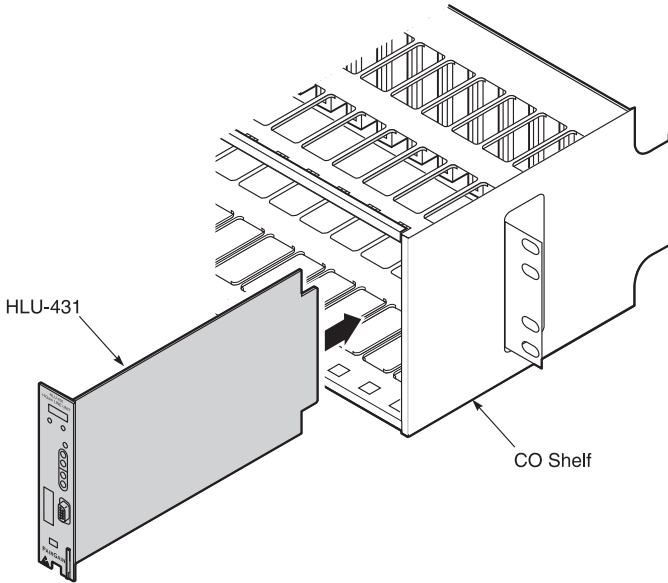

HDSL Line Voltage Option

The symmetry of the HDSL line powering voltage can be set by the S2 switch, located on the printed circuit board.

The factory default setting is Unipolar (-). It sets the HDSL line voltage to 0 V on loop 2 and to either -140 V (for non-doubler applications) or -200 V (for doubler applications) on loop 1.

The Bipolar selection sets the HDSL line voltage to +70 V on loop 2 and -70 V on loop 1, for non-doubler applications. Doubler applications will have +100 V on loop 2 and -100 V on loop 1. The symmetry of the HDSL line powering voltage can be set by the S2 switch, located on the printed circuit board.

Provisioning

The HLU-431 List 1D contains a non-volatile RAM (NVRAM) which stores the system option settings. The options are set via buttons on the front panel, or through the RS-232 interface. They are retained if shelf power is lost or if the HLU-431 List 1D is unplugged. The *System Options* table on page 8 lists the system options for the HLU-431 List 1D.

Using the SEL and Mode Front Panel Buttons

To provision the HLU-431 List 1D through the SEL and MODE front-panel buttons:

- 1 Press the MODE button for approximately one second. The message displayed on the front panel alternates between the first system parameter and its current setting.
- 2 Press the SEL button to step the display through all possible settings (one at a time) of the parameter being displayed.
- 3 Press the MODE button to select the desired parameter and move to the next parameter. After you have configured the last parameter, the display prompts you to confirm the settings.
- 4 Do one of the following:
 - Press the SEL button to install the settings.
 - Press the MODE button to bypass the settings.

If neither button is pressed in 30 seconds, the settings are bypassed.

Default Settings

To return the system options back to the original factory default settings:

- 1 Press the SEL button until the DFLT NO message appears.
- 2 Press the SEL button again and DFLT YES displays indicating the factory default values are now in effect.

To terminate the DFLT mode without setting the factory default values, press the MODE button or do nothing for 30 seconds.

Using the Craft port

The Craft port, a 9-pin RS-232 connector, on the HLU-431 front panel allows you to use a standard RS-232 cable to connect your system to a dumb terminal or PC running a terminal emulation program. Once connected you can access the maintenance, provisioning, and performance screens.

To provision the HLU-431 through the Craft port:

- 1 Configure the dumb terminal to the following communication settings:
 - 1200 to 9600 baud (9600 baud is recommended)
 - Parity: NONE
 - 8 data bits
 - 1 stop bit
 - Hardware Flow Control set to NONE
 - VT Terminal Emulation



If using the Microsoft Windows terminal emulation program, from the Settings, Terminal Preference menu, deselect *Show Scroll Bars* and *Use Function, Arrow, and Ctrl Keys for Windows*.

- 2 Use a serial cable to connect the RS-232 COM port on the dumb terminal to the HLU-431 front panel Craft port.

- 3 On each screen, enter the key represented by the letter in parenthesis for the parameter to be changed.
- Each entry of this letter scrolls the parameter to its next value.
 - After all selections have been made, press **E** to exit and **C** to confirm the changes. This activates the new choices and returns control to the Main Menu screen.

The following three user options cannot be set from the front panel buttons: Circuit ID, DS0 Blocking, and Margin Alarm Threshold.

System Options Settings

HLU-431 List 1D System Options

Mode	Selection	Description
EQL [†]	0*	Sets the equalizer to DSX-1 for 0 - 133 feet.
	133	Sets the equalizer to DSX-1 for 133 - 266 feet.
	266	Sets the equalizer to DSX-1 for 266 - 399 feet.
	399	Sets the equalizer to DSX-1 for 399 - 533 feet.
	533	Sets the equalizer to DSX-1 for 533 - 655 feet.
ZBTS	ON	Tells HiGain that the ESF frame is operating in its ZBTSI mode.
	OFF*	Tells HiGain that the ESF frame is operating in its normal non-ZBTSI mode.
ESAL	17	Activates the alarm input signal to the LITESPAN microprocessor and flashes the red STATUS LED when 17 Errored Seconds (ES) (17 HDSL CRC errors on either HDSL loop or a total of 17 BPVs and FERR) occur within a 24-hour period.
	170	Activates the alarm input signal to the LITESPAN microprocessor and flashes the red STATUS LED when 170 ES (170 HDSL CRC errors on either HDSL loop or a total of 170 BPVs and FERR) occur within a 24-hour period.
	NONE*	Prevents generation of an alarm due to excessive Errored Seconds.
ALM	DIS*	Disables assertion of the Alarm input signal to the LITESPAN processor from the HLU processor. Note the HDSL LED still flashes Red for an alarm condition even when the ALM DIS option is chosen.
	ENA	Enables assertion of the Alarm input signal to the LITESPAN processor from the HLU processor.

 HLU-431 List 1D System Options (Cont.)

Mode	Selection	Description
DS0	BLK	The DS0 blocking option can only be set through the RS-232 maintenance port with a terminal. The 4-character HLU-319 List 2D front panel LED readout only displays the BLK indicates at least one channel is blocked.
	NONE*	No channels are blocked.
LBTO	NONE	Disables automatic time-out cancellation of all loopbacks.
	20	Sets automatic cancellation of all loopbacks to 20 minutes after initiation.
	60*	Sets automatic cancellation of all loopbacks to 60 minutes after initiation.
	120	Sets automatic cancellation of all loopbacks to 120 minutes after initiation.
LPBK	DIS	Configures the HLU-200 to ignore the 2 in 5 Smart-Jack loopback command.
	ENA*	Enables the HLU-200 to respond to the 2 in 5 Smart-Jack loopback command.
SPLB	GNLB*	Configures the HiGain system to respond to the generic (3/4/5/6 in 7) in-band loopback codes.
	A1LB and A2LB	Configures the HiGain system to respond to the Teltrend addressable repeater in-band loopback codes.
	A3LB	Configures the HiGain system to respond to the Wescom addressable repeater in-band loopback codes.
	A4LB	Configures the HiGain system to respond to the Wescom Mod 1 addressable repeater in-band loopback codes.
	A5LB	Configures the HiGain system to respond to the Teltrend Mod 1 addressable repeater in-band loopback codes.
PWRF	DIS	Disables powering to the HRU and/or doubler over the HDSL pairs.
	ENA*	Enables powering to the HRU and/or doubler over the HDSL pairs.
DS1	B8ZS	Places both the HLU and HRU into their B8ZS modes.
	AMI*	Places both the HLU and HRU into their AMI modes.
	AUTO	The HLU and HRU independently monitor their incoming T1 bit streams for the B8ZS pattern. If either unit detects this pattern, it enters its B8ZS mode.

 HLU-431 List 1D System Options (Cont.)

Mode	Selection	Description
FRMG	AUTO*	Configures HiGain to operate in an auto-framing (AUTO) mode in which it continuously searches the input T1 bit stream for a valid SF or ESF frame pattern. This feature is required for fractional T1 applications (DS0 blocking) where it insures proper channel time slot alignment. While HiGain can also process unframed data in this AUTO mode, it is recommended that the UNFR mode be used for all unframed applications. Using the AUTO mode for unframed applications runs the risk of detecting "pseudo valid" frame sequences, which can affect the data integrity.
	UNFR	Configures HiGain to operate in an unframed mode. This mode disables the auto framing process and forces HiGain to function as a transparent bit pipe.
HAIS	2LP*	Causes HiGain to transmit the AIS signal at both the HLU and HRU T1 output ports when both of the HDSL loops are not in sync (LOSW).
	1LP	Causes HiGain to transmit the AIS signal at both the HLU and HRU T1 output ports when either of the two HDSL loops is not in sync (LOSW) or if a minor alarm occurs.
SAIS	ENA*	Causes the HRU to transmit the AIS signal towards the CI when in NREM loopback.
	DIS	Prevents the AIS signal from being transmitted to the NI and replaces it with the network test signal in the HRU List 6 and 8 or by a quiet termination (LOS) in the HRU List 7.
MARG	0 to 15 dB	The Margin Alarm Threshold determines the minimum allowable margin below which an alarm will occur.
	4*	Default value.
CONF	YES	Confirms that all operating modes (listed in this table) are to be updated to their current selections.
	NO*	Prevents the most recently selected operating mode selections from being updated. They remain as they were before the system options settings mode was entered.

Testing

The HLU-431 List 1D 4-character front panel display has many useful system diagnostic messages. They are listed in the following table. This display turns on when power is initially applied to the HLU-431 List 1D. To conserve power, the display only remains on for five minutes if neither the **MODE** or **SEL** buttons are pressed. The use of either button activates the 4-character display and restarts the 5-minute power-control timer.

Alarms

Only one alarm can be displayed at a time, therefore, only the highest priority alarm is displayed if more than one alarm exists. The following table lists the alarms in order of priority.

Status Menu Alarm Messages

Message	Full Name	Description
NONE	No Alarms	
LLOS	Local Loss of Signal	No signal at the HLU-431 List 1D local T1 interface.
RLOS	Remote Loss of Signal	No signal at the HRU remote T1 interface.
LOSW1 or LOSW2	Loss of Sync Word 1 or 2	HDSL loop 1 or 2 has lost sync.
H1ES or H2ES	HDSL Loop 1 or 2 Errored Second	Loop 1 or 2 CRC's have exceeded the user selected ES threshold.
DS1	Digital Service 1	DS1 input BPVs at the HRU have exceeded the user selected ES threshold.
RAIS or LAIS	Remote Alarm Indicating Signal	Indicates an AIS (all "1") pattern is being transmitted from the remote or T1 output port.
MAL1 or MAL2	Margin Alarm 1 or 2	The margin on HDSL loop 1 or 2 has dropped below the threshold (1 to 15 dB) set by the user.
CHREV	Channels Reserved	The Loop 1 and 2 HDSL pairs are reversed at the HRU input port. Loop 1 is specified to carry the (-) simplex DC voltage, and Loop 2 is specified to carry the (+) simplex DC voltage.
ACO	Alarm CutOff	A minor alarm occurred and was retired to an ACO condition after pressing the SEL button on the HLU front panel.

Loopbacks

The HLU-431 List 1D loopback messages are listed in the following tables. A block diagram showing the GNLB locations and their activation codes are shown on page 13.

Status Menu Loopback Messages: (with and without Doublers)

Message	Full Name	Description
SMJK	Smart-Jack Loopback	Loopback at HRU (remote) toward the CBA initiated by either the (2 in 5) in-band loopback code or the out-of-band ESF data link code.
NREM	Network Remote Loopback	Loopback at HRU (remote) toward the CBA initiated by upstream in-band codes or from the maintenance terminal.
NLOC	Network Local Loopback	Loopback at HLU, (local) toward the CBA initiated by upstream in-band codes or from the maintenance terminal.
CLOC	Customer Local Loopback	Loopback at HRU (local) toward CI initiated from CPE (customer) by in-band codes or from the maintenance terminal.
CREM	Customer Remote Loopback	Loopback at HLU, (remote) toward customer initiated from CPE (customer) by in-band codes or from the maintenance terminal.
ARM	Armed	The HiGain system detected the IR loopback (2 in 5) arming code.
TLOS	Transmit Loss of Signal (Loopback)	HRU is in a logic loopback state caused by a loss of its T1 input from the CI, if enabled at the HRU via its TLOS switch option.

Status Menu Loopback Messages: (Doublers Only)

Message	Full Name	Description
NDU1	Network Doubler 1 Loopback	The loopback at doubler 1 toward the CBA initiated by in-band codes, or the maintenance terminal.
NDU2	Network Doubler 2 Loopback	The loopback at doubler 2 toward the CBA initiated by in-band codes or the maintenance terminal.
CDU1	Customer Doubler 1 Loopback	The loopback at doubler 1 toward CI initiated by in-band codes or the maintenance terminal.
CDU2	Customer Doubler 2 Loopback	The loopback at doubler 2 toward CI initiated by in-band codes or the maintenance terminal.

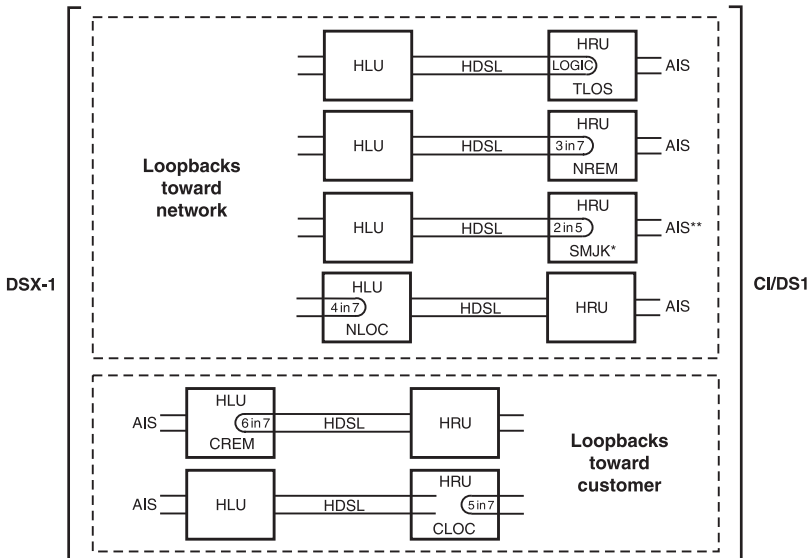

* The Smart-Jack loopback is a metallic loopback in the HRU Lists 6, 7 and 8. It is a logic loopback in HRU Lists 1 through 5.

** Set the SAIS option to ENA to send the AIS pattern to the CI during Smart-Jack Loopback.

Four-Character Diagnostic Messages

The HLU-431 diagnostic messages are listed in the table below.

Four-Character Front Panel Messages

Message	Full Name	Description
FERR	Framing Bit Error Occurred	Framing bit error occurred at HLU T1 input.
LBPV	Local Bipolar Violation	A bipolar violation has been received at the T1 input to the HLU-319.
SIG 1 or 2	Signal 1 or Signal 2	The HLU and HRU or 1st Doubler transceivers are trying to establish contact with each other on Loops 1 or 2 of span 1.
S2L1 or 2 [†]	Signal 2 Loop or Loop 2	The 1st Doubler and either HRU or 2nd Doubler transceivers are trying to establish contact with each other on loops 1 or 2 of span 2.
S3L1 or 2 [†]	Signal 3 Loop or Loop 3	The 2nd Doubler and HRU transceivers are trying to establish contact with each other on loops 1 or 2 of span 3.
ACQ 1 or 2	Acquisition 1 or Acquisition 2	The HLU and HRU or 1st Doubler multiplexers are trying to establish synchronization over each of Loops 1 or 2 of span 1.
A2L1 or 2 [†]	Acquisition 2 Loop 1 or Loop 2	The 1st Doubler and either HRU or 2nd Doubler multiplexers are trying to establish synchronization with each other on loops 1 or 2 of span 2.
A3L1 or 2 [†]	Acquisition 3 Loop 1 or Loop 2	The 2nd Doubler and either HRU multiplexers are trying to establish synchronization with each other on loops 1 or 2 of span 3.
ACO	Alarm CutOff	A minor alarm has occurred, and been retired to an ACO condition, by pressing the SEL button on the HLU front panel.
Self Test		The HLU is in a self test mode. This occurs every power ON/OFF cycle.
ALRM	Alarm Condition Exists	A minor alarm condition is in effect.

[†] These messages only apply to systems with doublers present.

Four-Character Front Panel Messages (Cont.)

Message	Full Name	Description
1=xx or 2=yy	HDSL Loop Margins	Indicates the power of the received HDSL signal on each Loop relative to noise. Any value of '06' or greater is adequate for reliable system operation.
PWR FEED SHRT	Power Feed Short	Indicates a short between the 2 HDSL pairs in span 1. This same message can occur with an HRU that is drawing the correct amount of power over good cable pairs but cannot communicate with the HLU.
PWR FEED OPEN	Power Feed Open	Indicates an open circuit in the T&R of either HDSL pair in span 1.
PWR FEED OFF	Power Feed Off	HDSL span power has been turned off by setting the PSFD option to DIS.
BAD RT?	No response from HRU	The HLU does not receive any response from the HRU. Thus, the HRU's integrity is questionable.
VER	HLU Software Version #	Displays during the System Settings review mode. Depress the MODE button for 3 seconds to view the software version.
LIST 0xL	HLU's List #	Displayed during System Settings review mode defined above.
FRM	Frame: SF, ESF, UNFR, NONE	Defines the type of frame pattern being received from the DSX-1. Displayed during System Settings mode defined above.
CODE	Line Code: AMI, B8ZS	This is the line code that HLU-431 List D is receiving at its DSX-1 interface. Displayed during System Setting review mode.
DSO	DSO Blocked Channels	Indicates status of DSO blocked channels. NONE indicates no channels are blocked. BLK indicates some channels are blocked.
MNGD	Managed	The HLU-431 List 2D is under control of the HLU network management unit. In this state, the RS-232 maintenance port on the HLU-431's front panel is inoperative.

† These messages only apply to systems with doublers present.

Specifications

Maximum Power Consumption

14 Watts (without Doubler); 23 Watts (with Doubler).

Maximum Heat Dissipation

6 Watts (without Doubler); 8 Watts (with Doubler).

Mounting

STS, high-density slot431

Dimensions

Height: 5.6" (14 c.m.)

Width: 1.4" (3.5 c.m.)

Depth: 5.6" (14 c.m.)

Weight: 1 lb. 2 oz.

Documentation

The HLU-431 List 1D has a complete technical practice that you can download from the PairGain Technical Manuals Web page at: www.pairgain.com. A password is required. If you do not have a password, contact your PairGain sales representative.

If you have any comments on any PairGain documentation, send mail to technical_publications@pairgain.com. Type the product name and the section number of the document in the subject area of the email message.

Technical Support

PairGain Technical Assistance is available 24-hours-a-day, 7-days-a-week by contacting PairGain Customer Service Engineering group at:

Telephone: (800) 638-0031 or (714) 832-9922

Fax: (714) 832-9924

During normal business hours (8:00 AM to 5:00 PM, Pacific Time, Monday - Friday, excluding holidays), technical assistance calls are normally answered directly by a Customer Service Engineer. At other times, a request for technical assistance is handled by an on-duty Customer Service Engineer through a callback process. This process normally results in a callback within 30 minutes of initiating the request.

Bulletin Board Services

PairGain maintains a computer bulletin board system for obtaining current information on PairGain products, product troubleshooting tips and aids, accessing helpful utilities, and for posting requests or questions. This system is available 24-hours-a-day by calling (714) 730-3299. Transmission speeds up to 28.8 Kbps are supported with a character format of 8-N-1.

Corporate Office
14402 Franklin Avenue
Tustin, CA 92780

Tel: (714) 832-9922
Fax: (714) 832-9924

For Technical Assistance:
(800) 638-0031



 **PAIRGAIN**
THE COPPEROPTICS COMPANY