

HiGAIN LINE UNIT

QUICK INSTALLATION GUIDE

Model	List	Part Number	CLEI Code
HLU-611	1	150-1217-01	T1LIUC04AA

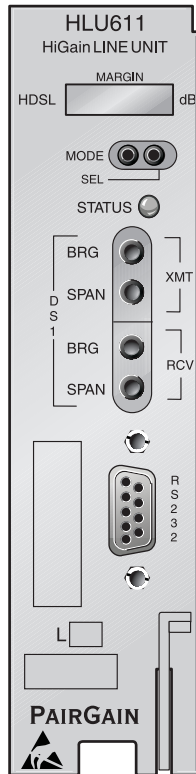

PAIRGAIN TECHNOLOGIES, INC.

SECTION 350-611-101-01

Revision History of this guide.

Revision 01—March 17, 1998

A) Initial Release

Table of Contents

Introduction	1
Features	2
Compatibility	4
Installation	4
HLU-611 Card-Edge Connectors	5
Installing the HLU-611	6
Provisioning	7
Using the SEL and MODE Front Panel Buttons	7
Default Settings.....	7
Using the Craft port	8
System Options Settings	9
Testing	13
Alarms.....	13
Loopbacks	14
Four-Character Diagnostic Messages	16
Specifications	17
Documentation	18
Technical Support	18
Bulletin Board Services	18

Copyright © 1998 PairGain Technologies, Inc.

PairGain is a registered trademark and HiGain is a trademark of PairGain Technologies, Inc.

Information contained in this document is company private to PairGain Technologies, Inc., and shall not be modified, used, copied, reproduced or disclosed in whole or in part without the written consent of PairGain.

Other product names mentioned in this practice are used for identification purposes only and may be trademarks or registered trademarks of thier respective companies.

INTRODUCTION

The PairGain® HiGain™ Line Unit Model HLU 611 Issue 1 List 1 (Part Number 150-1217-01) is the Central Office (CO) side of a repeaterless T1 transmission system. It is used in conjunction with the HRU-612 Remote Unit to provide a complete HiGain Very High-bit-rate Digital Subscriber Line (VHDSL) system on one non-loaded copper pair over the cable lengths shown in the following table at the line rate of 392 kHz.

Cable Gauge	Loss @ 392 kHz dB/kft	Ohms per kft	Maximum Loop for 35 dB Loss	Ohms @ Maximum Loop Length
26/0.4 mm	4.97	83.3	7.0 kft/2.13 km	583
24/0.51 mm	3.87	51.9	9 kft/2.74 km	467
22/0.61 mm	3.01	32.4	12 kft/3.66 km	389
19/0.91 mm	2.17	16.1	16 kft/4.87 km	358



The HLU-611 does not support doublers.

For more detailed information consult the HLU-611 List 1 Technical Practice (Section Number 150-611-101).

Features

The HLU-611 List 1 Line Unit front panel features are:

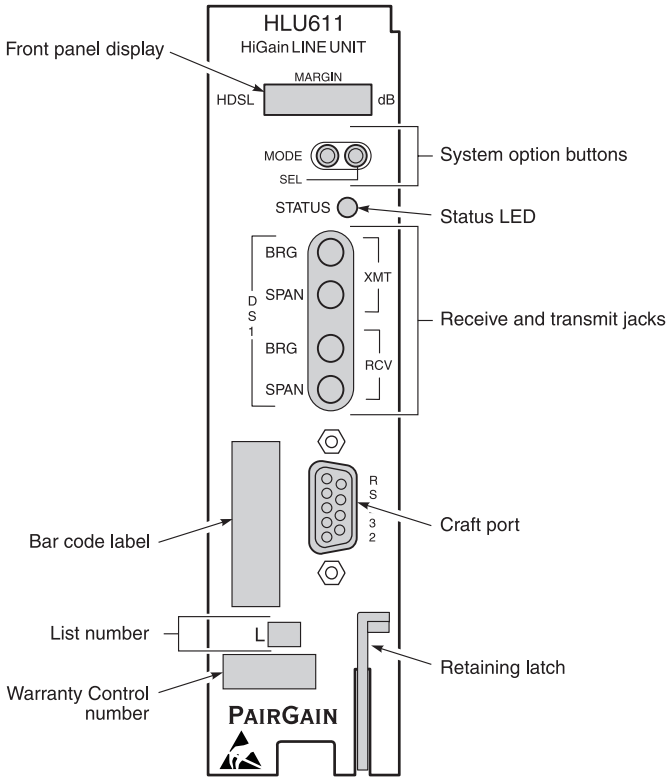

The HLU-611 List 1 front panel components are:

Name	Function
Front panel display	Four character LCD that provides status messages for VHDSL, S/N margin, optional settings and alarms.
System option buttons	MODE and SEL (Select) buttons used to set system modes.
Status LED	Tri-color LED that indicates system state: Green Normal Operation Flashing Green VHDSL Acquisition Flashing Red Minor Alarm Red FUSE ALRM Yellow Self Test in progress or an HLU-611 List1 loopback in effect (CREM) or (NLOC) Flashing Yellow The HLU-611 intelligent loopback is in an ARMED state
Receive (RCV) and Transmit (XMT)	Splitting access and bridging "210-Bantam" type jacks.
Craft port	RS-232 connector that provides access to the maintenance, provisioning, and performance monitoring interface through a dumb terminal.
Retaining latch	Secures the HLU-611 to the shelf in which it is installed.

Compatibility

The HLU-611 List 1 is designed to mount in the following shelves:

- 200-configuration Office Repeater Bay (ORB) shelf or equivalent Small Cross Section Shelf (SXSS)
- Kentrox T-Term
- Wescom 342-30 shelves
- PairGain HCS-418 (19") shelf
- PairGain HCS-417 (23") shelf
- PairGain HCS-402 (2 slot) shelf

INSTALLATION

Upon receipt of the equipment, visually examine it for signs of damage. If the equipment has been damaged in transit, immediately report the extent of damage to the transportation company and to PairGain Technologies. For PairGain Technical Assistance 24-hours-a-day, 7-days-a-week, contact the Customer Service Engineering group at (800) 638-0031 or (714) 832-9922 or fax the group at (714) 832-9924.

HLU-611 Card-Edge Connectors

The HLU-611 List 1 card-edge connector pinouts are shown below. The HLU-611 List 1 uses pins 20 and 21 as alarm-relay output. The Kentrox 220 T-Term shelf uses the same pins for external equalizer output. If the HLU-611 is installed into a Kentrox shelf, the HLU-611 ALM option must be disabled.

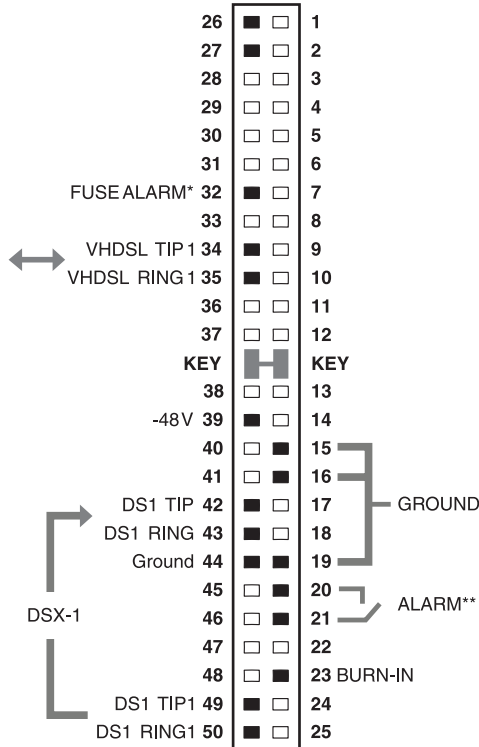

* Fuse alarm is normally floating and at -48V when activated.

** Minor alarm contacts (pins 20 and 21) are normally open and close upon alarm.

Installing the HLU-611

To install the HLU-611 List 1 into the shelf, slide the unit into the shelf card guides for the desired slot. Push the unit in until it is entirely within the card guide. The retaining latch locks into place, indicating that the unit is properly seated.

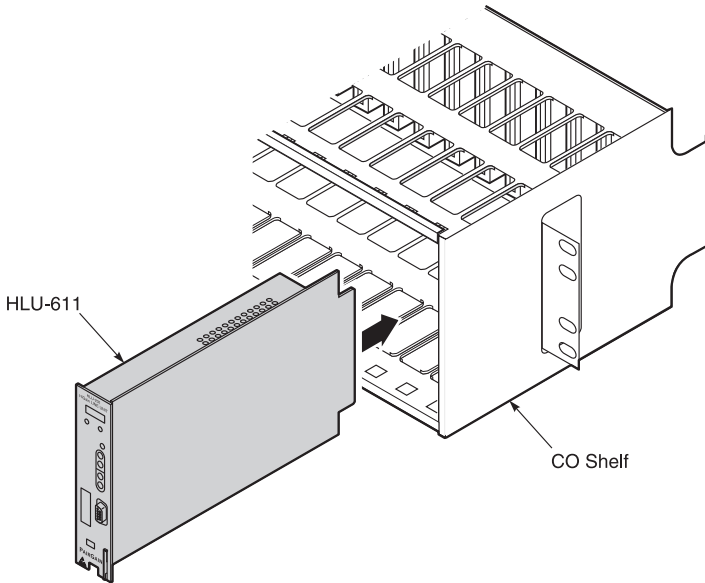

PROVISIONING

The HLU-611 List 1 contains a non-volatile RAM (NVRAM) which stores the system option settings. The options are set from the buttons on the front panel, or through the RS-232 interface. They are retained if shelf power is lost or if the HLU-611 List 1 is unplugged. See page 9 for the HLU-611 List 1 *System Options* table.

Using the SEL and MODE Front Panel Buttons

To provision the HLU-611 List 1 through the SEL and MODE front-panel buttons:

- 1 Press the **MODE** button for approximately one second. The message displayed on the front panel alternates between the first system parameter and its current setting.
- 2 Press the **SEL** button to step the display through all possible settings (one at a time) of the parameter being displayed.
- 3 Press the **MODE** button to select the desired parameter and move to the next parameter. After you have configured the last parameter, the display prompts you to confirm the settings.
- 4 Do one of the following:
 - Press the **SEL** button to install the settings.
 - Press the **MODE** button to bypass the settings.
 - If neither button is pressed in 30 seconds, the settings are bypassed.

Default Settings

To return the system options back to the original factory default settings:

- 1 Press the **SEL** button until the DFLT NO message appears.
- 2 Press the **SEL** button again and DFLT YES displays indicating the factory default values are now in effect.

To terminate the DFLT mode without setting the factory default values, press the **MODE** button or do nothing for 30 seconds.

Using the Craft port

The Craft port, a 9-pin RS-232 connector, on the HLU-611 front panel allows you to use a standard RS-232 cable to connect your system to a dumb terminal or PC running a terminal emulation program. Once connected you can access the maintenance, provisioning, and performance screens.

To provision the HLU-611 through the Craft port:

- 1 Configure the dumb terminal to the following communication settings:
 - 1200 to 9600 baud (9600 baud is recommended)
 - Parity: NONE
 - 8 data bits
 - 1 stop bit
 - Hardware Flow Control set to NONE
 - VT Terminal Emulation



If using the Microsoft Windows terminal emulation program, from the Settings, Terminal Preference menu, deselect *Show Scroll Bars* and *Use Function, Arrow, and Ctrl Keys for Windows*.

- 2 Use a serial cable to connect the RS-232 COM port on the dumb terminal to the HLU-611 front panel Craft port.
- 3 On each screen, enter the key represented by the letter in parenthesis for the parameter to be changed.
 - Each entry of this letter scrolls the parameter to its next value.
 - After all selections have been made, press **E** to exit and **C** to confirm the changes. This activates the new choices and returns control to the Main Menu screen.

The following three user options must be set via the dumb terminal interface: Circuit ID, Time and Date, DS0 Blocking, and Margin Alarm Threshold.

System Options Settings

The asterisks (*) in the following system settings descriptions indicate the factory default settings. To return the HLU to the default settings, press the SEL button for 6 seconds. The Margin threshold and DSX blinking options must be set from the RS-232 port. All other options can be set from either the front panel or RS-232 port.

HLU-611 List 1 System Options

Mode	Selection	Description
EQL	EXT*	Replaces the internal equalizer with a 12 V _{pk-pk} drive source for an external equalizer.
	0	Sets the equalizer to DSX-1 for 0 - 133 feet.
	133	Sets the equalizer to DSX-1 for 133 - 266 feet.
	266	Sets the equalizer to DSX-1 for 266 - 399 feet.
	399	Sets the equalizer to DSX-1 for 399 - 533 feet.
	533	Sets the equalizer to DSX-1 for 533 - 655 feet.
ZBTS	ON	Selects the Extended Superframe (ESF) frame ZBSTI mode.
	OFF*	Deselects the ESF frame ZBSTI mode.
LPBK	DIS	Configures the HLU-611 to ignore the 2 in 5 Smart-Jack loopback command.
	ENA*	Enables the HLU-611 to respond to the 2 in 5 Smart-Jack loopback command.
LBTO	NONE	Disables automatic time-out cancellation of all loopbacks.
	20	Sets automatic cancellation of all loopbacks to 20 minutes after initiation.
	60*	Sets automatic cancellation of all loopbacks to 60 minutes after initiation.
	120	Sets automatic cancellation of all loopbacks to 120 minutes after initiation.

HLU-611 List 1 System Options (Continued)

Mode	Selection	Description
ESAL	17	Closes the alarm relay contacts across pins 20 and 21 and flashes the red STATUS LED when 17 ES (17 HDSL CRC errors on either HDSL loop or a total of 17 BPVs) occur within a 24-hour period.
	170	Closes the alarm relay contacts across pins 20 and 21 and flashes the red STATUS LED when 170 ES (170 HDSL CRC errors on either HDSL loop or a total of 170 BPVs) occur within a 24-hour period.
	NONE*	Prevents generation of an alarm due to excessive Errored Seconds.
SPLB	GNLB	Configures the HiGain system to respond to the generic (3/4/5/6 in 7) in-band loopback codes.
	A1LB and A2LB*	Configures the HiGain system to respond to the Teltrend addressable repeater in-band loopback codes.
	A3LB	Configures the HiGain system to respond to the Wescom addressable repeater in-band loopback codes.
	A4LB	Configures the HiGain system to respond to the Wescom Mod 1 addressable repeater in-band loopback codes.
	A5LB	Configures the HiGain system to respond to the Teltrend Mod 1 addressable repeater in-band loopback codes.
PWRF	DIS	Disables powering to the HRU-612 over the HDSL pairs.
	ENA*	Enables powering to the HRU-612 over the HDSL pairs.
DS1	B8ZS	Places both the HLU and HRU into their B8ZS modes.
	AMI*	Places both the HLU and HRU into their AMI modes.
	AUTO	The AUTO mode is not supported. If selected, the DS1 code defaults to AMI.

HLU-611 List 1 System Options (Continued)

Mode	Selection	Description
FRMG	AUTO*	Configures HiGain to operate in an auto-framing (AUTO) mode in which it continuously searches the input T1 bit stream for a valid Superframe or Extended Superframe pattern. This feature is required for fractional T1 applications (DS0 blocking) where it insures proper channel time slot alignment. While HiGain can also process unframed data in this AUTO mode, it is recommended that the UNFR mode be used for all unframed applications. Using the AUTO mode for unframed applications runs the risk of detecting õpseudo validó frame sequences, which can affect the data integrity.
	UNFR	Configures HiGain to operate in an unframed mode. This mode disables the auto framing process and forces HiGain to function as a transparent bit pipe.
HAIS	2LP*	Causes HiGain to transmit the AIS signal at both the HLU and HRU T1 output ports when both of the HDSL loops are not in sync (LOSW).
	1LP	Cause HiGain to transmit the AIS signal at both the HLU and HRU T1 output ports when either of the two HDSL loops are not in sync (LOSW) or if a margin alarm occurs.
CONF	YES	Confirms that all twelve operating modes (listed above) are to be updated to their current selections.
	NO*	Prevents the most recently selected operating mode selections from being updated. They remain as they were before the system option settings mode was entered.
SAIS	ENA*	Causes the HRU-612 to transmit the AIS signal towards the Network Interface (NI) when in NREM or Smart-Jack loopback.
	DIS	Causes the List 1 HRU-612 to transmit the signal from the network towards the NI and the HRU-612 List 2 to open and terminate its RCV NI port when an HRU NREM or Smart-Jack loopback is executed. The AIS signal is off.
DS0	BLK	The DS0 blocking option can only be set via the RS-232 maintenance port with a terminal. The 4-character HLU-611 List 1 front panel LED readout only displays the status of the blocking option. BLK indicates at least one channel is blocked.
	NONE*	NONE indicates no channels are blocked.

HLU-611 List 1 System Options (Continued)

Mode	Selection	Description
MARGin Alrm Thrs	0 to 15 dB	The Margin Alarm Threshold can only be set via the RS-232 maintenance port with a terminal. It determines the minimum allowable margin below which a minor alarm can occur.
	4 dB*	(Default value)
ALM	DIS*	Opens the relay alarm contacts, if closed, and prevents another relay alarm closure from occurring.
	ENA	Enables activation of the minor alarm relay when a minor alarm condition occurs.

*Indicates HLU-611 factory (default) settings.

TESTING

Minor alarm and diagnostic messages routinely appear on the HLU-611 List 1 front-panel four-character display. This display turns on when power is initially applied to the HLU-611 List 1. To conserve power, the display only remains on for five minutes if neither the **MODE** or **SEL** buttons are pressed. The use of either button activates the 4-character display and restarts the 5-minute power-control timer.

Alarms

Only one alarm can be displayed at a time, therefore, only the highest priority alarm is displayed if more than one alarm exists. The following table lists the alarms ordered by priority.

Status Menu Alarms Messages

Message	Full Name	Description
NONE	No Alarms	
LLOS	Local Loss of Signal	No signal from HLU-611 List 1 local T1 interface.
RLOS	Remote Loss of Signal	No signal from HRU-612 remote T1 interface.
LOSW	Loss of Sync Word	The VHDSL's loop has lost sync.
HES	VHDSL Errored Second	The VHDSL CRC count has exceeded the user-selected ES threshold.
DS1	Digital Service 1	DS1 input BPVs at the HRU-612 have exceeded the user selected ES threshold.

Loopbacks

The HLU-611 List 1 loopback messages are listed in the following table.

Loopback Messages

Message	Full Name	Description
SMJK	Smart-Jack Loopback	Loopback at HRU toward the CBA initiated by either the (2 in 5) in-band loopback code or the out-of-band ESF data link code.
NREM	Network Remote Loopback	Loopback at HRU toward the CBA initiated by upstream in-band codes or from the maintenance terminal.
NLOC	Network Local Loopback	Loopback at HLU toward the CBA initiated by upstream in-band codes or from the maintenance terminal.
CLOC	Customer Local Loopback	Loopback at HRU toward CI initiated from CPE (customer) by in-band codes or from the maintenance terminal.
CREM	Customer Remote Loopback	Loopback at HLU toward customer initiated from CPE (customer) by in-band codes or from the maintenance terminal.
ARM	Armed	The HiGain system detected the IR loopback (2 in 5) arming code.
TLOS	Transmit Loss of Signal (Loopback)	HRU is in a logic loopback state caused by a loss of its T1 input from the CI, if enabled at the HRU via its TLOS switch option.

A block diagram showing the GNLB locations and their activation codes are shown below.

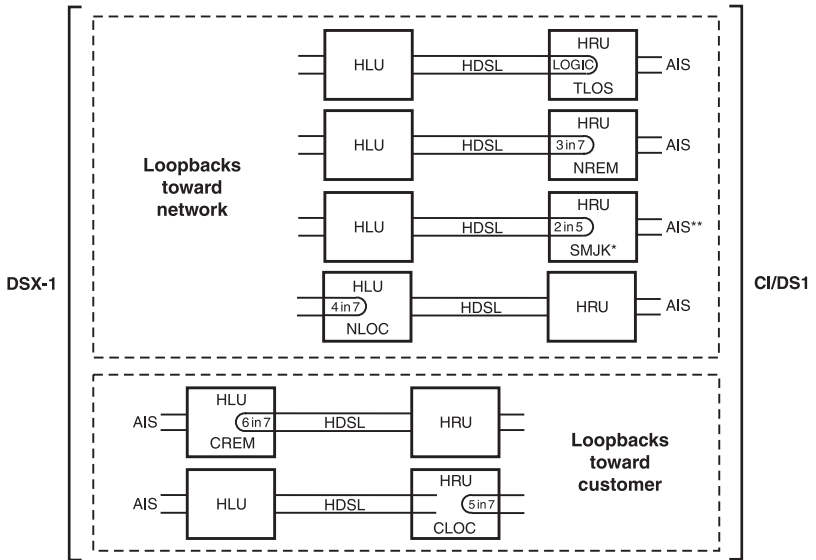

** Set the SAIS option to ENA to send the AIS pattern to the CI during Smart-Jack Loopback.

Four-Character Diagnostic Messages

The HLU-611 List 1 diagnostic messages are listed in the table below.

Four-Character Diagnostic Messages

Message	Full Name	Description
FERR	Framing Bit Error Occurred	Framing bit error occurred at HLU T1 input.
LBPV	Local Bipolar Violation	A bipolar violation has been received at the T1 input to the HLU-611.
SIG	Signal	The HLU & HRU transceivers are trying to establish contact with each other.
ACQ	Acquire	The HLU & HRU multiplexers are trying to establish synchronization over each.
ACO	Alarm CutOff	A minor alarm has occurred, and been retired to an ACO condition, by pressing the SEL button on the HLU front panel.
Self Test		The HLU is in a self test mode. This occurs every power ON/OFF cycle.
ALRM	Alarm Condition Exists	A minor alarm condition is in effect.
M=X	VHDSL Loop Margin	Indicates the power of the received VHDSL signal on each Loop relative to noise. Any value of '06' or greater is adequate for reliable system operation.
PWR FEED SHRT	Power Feed Short	Indicates a short across the VHDSL pairs in span 1. This same message can occur with an HRU that is drawing the correct amount of power over good cable pairs but cannot communicate with the HLU.
PWR FEED OPEN	Power Feed Open	Indicates an open circuit in the T&R of either VHDSL pair.
PWR FEED OFF	Power Feed Off	VHDSL span power has been turned off.
BAD RT?	No response from HRU	The HLU does not receive any response from the HRU. Thus, the HRU's integrity is questionable.

Four-Character Diagnostic Messages (Continued)

Message	Full Name	Description
VER	HLU Software Version #	This is displayed during the System Settings review mode. Depress the MODE button for 3 seconds to enter System Settings review mode.
LIST 0xL	HLU's List #	Displayed during System Settings review mode defined above.
FRM	Frame: SF, ESF, UNFR, NONE	Defines the type of frame pattern being received from the DSX-1. Displayed during System Settings mode defined above.
CODE	Line Code: AMI, B8ZS	This is the line code that the HLU is set to receive and transmit at its DSX-1 interface. Displayed during System Settings mode defined above.
DS0	DS0 Blocked Channels	Indicates status of DS0 blocked channels. NONE indicates no channels are blocked. BLK indicates some channels are blocked.

SPECIFICATIONS

Power Consumption

14 Watts (typical); 18 Watts (maximum)

Heat Dissipation

6 Watts (typical) 8 Watts (maximum)

Mounting

220 Mechanics

Dimensions

Height:	5.6" (15 cm)
Width:	1.4" (3.5 cm)
Depth:	10" (25.4 cm)

DOCUMENTATION

The HLU-611 List 1 has a complete technical practice that you can download from the PairGain Technical Manuals Web page at: www.pairgain.com. A password is required. If you do not have a password, contact your PairGain sales representative.

If you have any comments on any PairGain documentation, send mail to technical_publications@pairgain.com. Type the product name and the section number of the document in the subject area of the email message.

TECHNICAL SUPPORT

PairGain Technical Assistance is available 24-hours-a-day, 7-days-a-week by contacting PairGain Customer Service Engineering group at:

Telephone: (800) 638-0031 or (714) 832-9922

Fax: (714) 832-9924

During normal business hours (8:00 AM to 5:00 PM, Pacific Time, Monday-Friday, excluding holidays), technical assistance calls are normally answered directly by a Customer Service Engineer. At other times, a request for technical assistance is handled by an on-duty Customer Service Engineer through a callback process. This process normally results in a callback within 30 minutes of initiating the request.

Bulletin Board Services

PairGain maintains a computer bulletin board system for obtaining current information on PairGain products, product troubleshooting tips and aids, accessing helpful utilities, and for posting requests or questions. This system is available 24-hours-a-day by calling (714) 730-3299. Transmission speeds up to 28.8 kbps are supported with a character format of 8-N-1.

Corporate Office

14402 Franklin Avenue
Tustin, CA 92780

Tel: (714) 832-9922

Fax: (714) 832-9924

For Technical Assistance:

(800) 638-0031

