

QUICK INSTALLATION

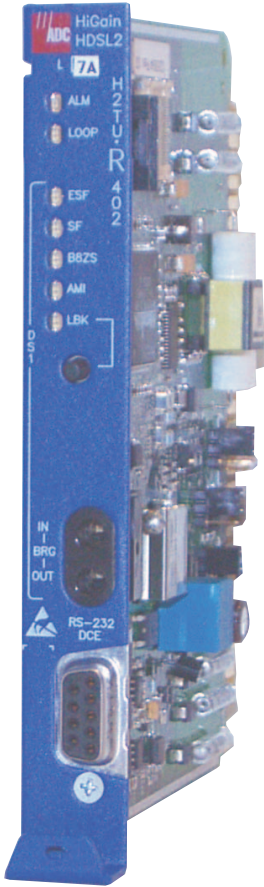

**HIGAIN H2TU-R-402 LIST 7A
REMOTE UNIT**

THE H2TU-R-402 LIST 7A

The H2TU-R-402 List 7A (H2TU-R) functions as the remote end of a repeaterless T1 transmission system when connected to a HiGain[®], Soneplex[®], or LoopStar HDSL2 line unit (H2TU-C). Setting new standards for interoperability and efficiency, HiGain HDSL2 modules transmit 1.544 Mbps T1 payload on one unconditioned copper pair over the full Carrier Service Area (CSA) range.

FEATURES

Front panel: status LEDs, craft port for maintenance screen access, DS1 bridging jacks, and LBK pushbutton for activating loopback commands

Maintenance screens for inventory, provisioning, performance monitoring, and troubleshooting, including:

- Loop attenuation and insertion loss reporting

- HDSL2 Tip/Ring reversal indication
- Power Back Off (PBON and PBOC) for configuring HDSL2 transmit power to reduce crosstalk
- Automatic circuit retrain to ensure quality service
- Enhanced lightning protection

Power: local or line

Sealing current option

SPECIFICATIONS

Operating Temperature	-40°F to +149°F (-40°C to + 65°C)
Operating Humidity	5% to 95% non-condensing
Line Power Consumption	2.8 Watts
Electrical Protection	Secondary surge and power cross-protection on all DS1 and HDSL2 ports
Mounting	Any 400 or 200 mechanics shelf
HDSL2 Line Rate	1.552 Mbps Overlapped Pulse amplitude modulated Transmission with Interlocking Spectra (OPTIS)
HDSL2 Output	+16.5 dBm \pm 0.5 dBm, 135 Ω
DS1 Pulse Output	0 dB, -7.5 dB, -15 dB
DS1 Receiver Sensitivity	36 dB at 100 Ω
Maximum Insertion Loss	35 dB at 196 KHz, 135 Ω
Maximum Loop Attenuation	28 dB
DS1 Line Rate	1.544 Mbps \pm 200 bps
DS1 Line Format	Alternate Mark Inversion (AMI) or Bipolar with 8-zero Substitution (B8ZS)
DS1 Frame Format	Extended SuperFrame (ESF), SuperFrame (SF), or Unframed (UNFR)



To ensure proper operation, the H2TU-R-402-L7A requires either the LPS-H2C-L7A, H2TU-C-231-L7A, H2TU-C-319-L7A, or H2TU-C-388-L7A to be used as the corresponding line unit.

1

INSTALLATION

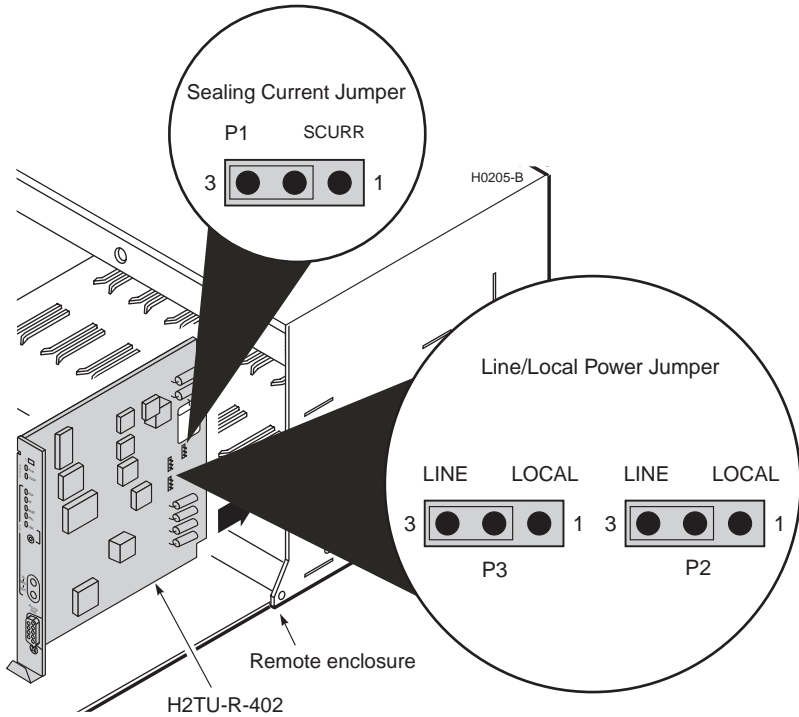

Wear an antistatic wrist strap when installing the H2TU-R. Avoid touching components on the circuit board.

- 1 Configure the H2TU-R for line or local power, as follows:
 - For line power, place a jumper on pins 2 and 3 of P2 and P3.
 - For local power, place a jumper on pins 1 and 2 of P2 and P3.
- 2 Check the setting of the Sealing Current (SCURR) jumper (P1). The default setting is disabled (jumper on pins 2 and 3). If the H2TU-R is locally powered and your application requires sealing current, place a jumper on pins 1 and 2.
- 3 Align the H2TU-R with the enclosure slot guides and slide the unit in. Push the unit back until it touches the backplane card-edge connector.
- 4 Place your thumbs on the front panel and push the H2TU-R into the card-edge connector.

Continued



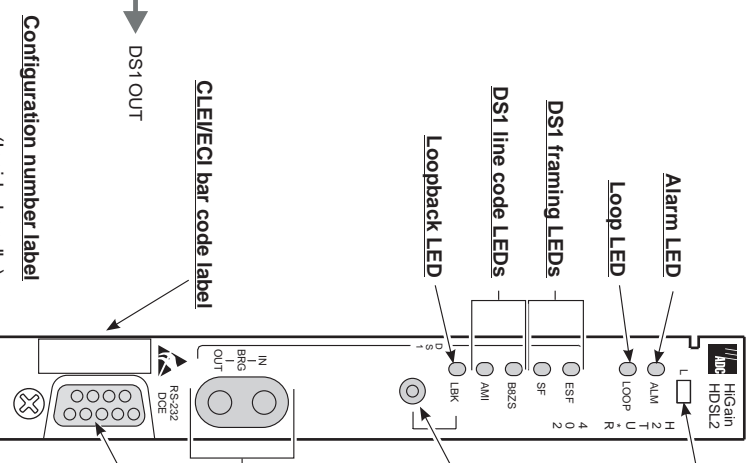
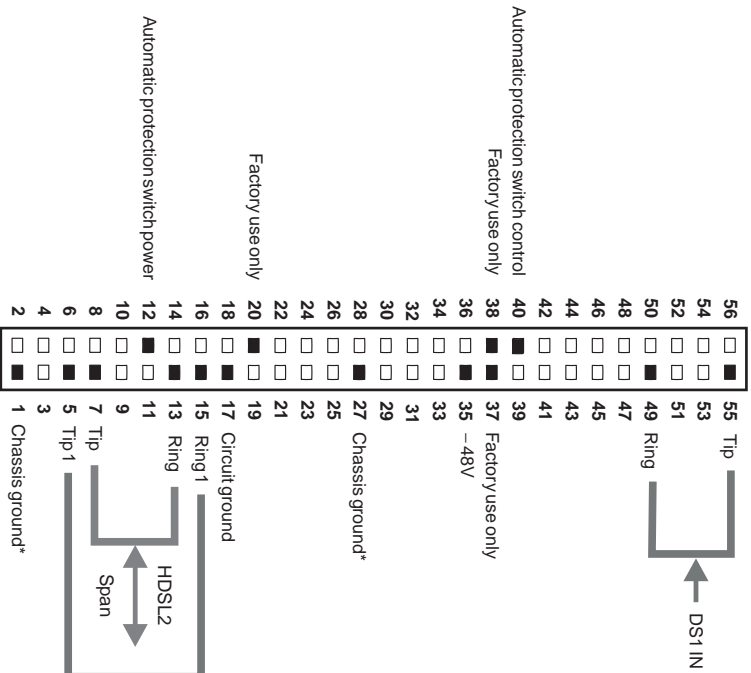

Maintenance Terminal Modem Settings	
9600 baud	
8 data bits	
No parity	
1 stop bit	
Hardware flow control: OFF	
Terminal emulation: VT100	

List number

Loopback control pushbutton

Press the pushbutton for 5 seconds to activate a loopback towards the customer at the Central Office (CREM). Any existing loopback is terminated before these loopbacks are activated. The unit can be looped down by pressing the LPBK control pushbutton again for 5 seconds, by the standard loopdown inband messages, or by the maintenance terminal.

DS1 transmit (IN) and receive (OUT) bridging jacks

For non-intrusive test access.

Craft port provisioning

To access all system maintenance, provisioning and performance screens, connect a standard 9-pin terminal cable between the serial port on a PC and the H2TU-R craft port.

Extraction handle

Use to remove the H2TU-R-402 from its slot.

* Chassis ground must be tied to Earth ground or network ground according to local practice.

2 VERIFICATION

Once the H2TU-R is installed, verify that it is operating properly by monitoring the Status LEDs on the front panel.

Status LED Descriptions

LED/Status	Function
ALM	
Solid red	Remote Loss of DS1 Signal (RLOS) present at the H2TU-R.
Flashing red once per second	Local Loss of DS1 Signal (LLOS) present at the H2TU-C.
Loop	
OFF	No activity on the HDSL2 loop.
Solid green	Normal operation: the HDSL2 span is synchronized.
Flashing green once per second	HDSL2 loop synchronization attempt.
Flashing green 4 times per second	HDSL2 margin alarm or loop attenuation alarm present at the H2TU-R.
Flashing green 10 times per seconds	HDSL2 CRC error present at the H2TU-R.
ESF	
OFF	Unframed DS1 present at the H2TU-R or no DS1 detected at the H2TU-R.
Solid green	ESF framing present on the incoming DS1 signal.
Flashing green once per second	ESF framing and frame error/CRC present on the incoming DS1 signal.
SF	
OFF	Unframed DS1 present at the H2TU-R or no DS1 detected at the H2TU-R.
Solid green	SF framing present on the incoming DS1 signal.
Flashing green once per second	SF framing and frame error present on the incoming DS1 signal.
B8ZS	
OFF	HDSL2 span is not synchronized (no DS1 signal detected).
Solid green	B8ZS is provisioned or is detected when set to AUTO.
Flashing green once per second	B8ZS and string of excess zeros detected on the incoming DS-1 signal.
AMI	
OFF	HDSL2 span is not synchronized (no DS1 signal detected).
Solid green	AMI is provisioned or detected when set to AUTO.
Flashing green once per second	AMI and BPV detected on the incoming DS-1.
LBK	
Solid yellow	Loopback in H2TU-R towards network (NREM, SMJK, or TLOS).
Flashing yellow once per second	Loopback in H2TU-R towards customer.
Flashing yellow 4 times per second	System ARMED for loopback.

3 LOGGING ON TO THE MAIN MENU

The H2TU-R supports local and remote logon through a maintenance terminal (ASCII terminal or a PC running terminal emulation software) connected to the craft port on the H2TU-R front panel.

Logging on creates menus and screens for the H2TU-R that are replications of those viewed at the H2TU-C. Once logged on, you can view system settings and inventory, initiate loopbacks, monitor performance, and configure the circuit.

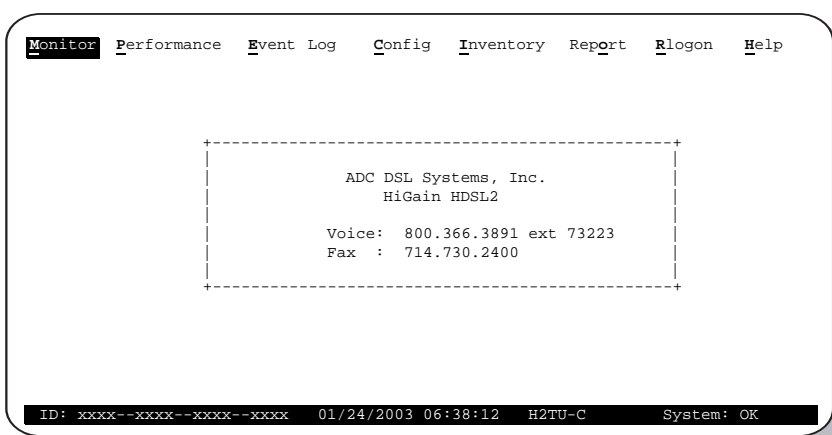

To log on using a maintenance terminal:

- 1 Press **CTRL** + **R** to refresh the Logon screen, if necessary.
- 2 Press the first letter of the desired menu. Use the **SPACEBAR** to cycle through menu selections, and press **ENTER** to change a setting or to display a menu.

Type the first letter **To view:**

M onitor	A graphical representation of circuit activity and devices.
P erformance	Performance history statistics (current, 25-hour, 48-hour, 31-day, and blockage indicator) at DS1 and HDSL interfaces. Also, displays alarm status and count.
E vent log	Sectionalized Event History for alarms and errors at all four legs of the DS1 signal at the H2TU-R.
C onfig	Configuration options (standard, ADC, signal generation, date and time, master clear, factory defaults).
I nventory	Product information, circuit and unit identifications.
R egon	Maintenance terminal screens at the H2TU-C.
H elp	Glossary, screen navigation keys, ADC contact information.
Rep O rt	Downloading status and performance monitoring data to file.



For more information about the HDSL2 line unit maintenance screens, refer to the H2TU-C line unit user manual. Copies of ADC line unit user manuals can be downloaded from the ADC website at www.adc.com. To order a hard copy, please contact your sales representative.

4 LOOPBACK TESTING

Initiate loopback testing from the maintenance menus, H2TU-R front-panel pushbutton, H2TU-C front-panel pushbuttons, or with inband codes sent by a test set (see table below). For more information about loopback testing, refer to the H2TU-C line unit user manual.

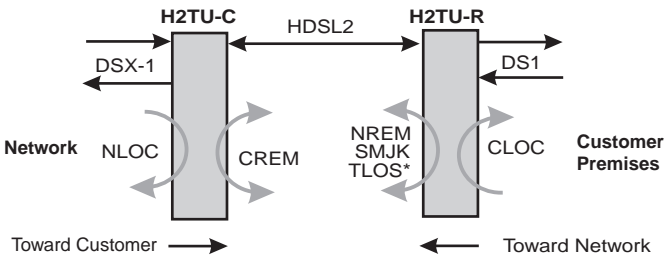

* When enabled, TLOS is an automatic loopback that occurs with an LOS at the remote DS1 input.

H0025-B

Loopback Commands

Loopback	Inband Code	Description
NLOC	1111000	DSX-1 signal is looped back to the network at the H2TU-C.
NREM	1110000	DSX-1 signal is looped back to the network at the H2TU-R.
SMJK	11000	DSX-1 signal is looped back to the network at the H2TU-R SmartJack module.
CREM	1111110	DS1 signal from customer is looped back to the customer at the H2TU-C.
CLOC	1111100	DS1 signal from customer is looped back to the customer at the H2TU-R.
Loopdown	11100	Deactivates any of the above loopbacks.

FCC Class A Compliance

This equipment has been tested and found to comply with the limits for a Class A digital device, pursuant to Part 15 of the FCC Rules. These limits are designed to provide reasonable protection against harmful interference when the equipment is operated in a commercial environment. This equipment generates, uses, and can radiate radio frequency energy and, if not installed and used in accordance with the instruction manual, may cause harmful interference to radio communications. Operation of this equipment in a residential area is likely to cause harmful interference in which case the user will be required to correct the interference at his own expense.

Limited Warranty

Product warranty is determined by your service agreement. Contact your sales representative or Customer Service for details.

Modifications

Any changes or modifications made to this device that are not expressly approved by ADC DSL Systems, Inc. voids the user's warranty.

All wiring external to the products should follow the provisions of the current edition of the National Electrical Code.

Standards Compliance

This equipment has been tested and verified to comply with the applicable sections of the following safety standards:

- GR 63-CORE - Network Equipment-Building System (NEBS) Requirements
- GR 1089-CORE - Electromagnetic Compatibility and Electrical Safety
- Binational standard, UL-60950/CSA C22.2 No. 60950-00 Third Edition: Safety of Information Technology Equipment.

Trademark Information

ADC is a registered trademark of ADC Telecommunications, Inc. Other product names mentioned in this installation guide are used for identification purposes only and may be trademarks or registered trademarks of their respective companies.

Copyright Information

© 2003 ADC DSL Systems, Inc. All rights reserved. Information contained in this document is company private to ADC DSL Systems, Inc., and shall not be modified, used, copied, reproduced or disclosed in whole or in part without the written consent of ADC.

World Headquarters

ADC Telecommunications, Inc.
PO Box 1101
Minneapolis, MN 55440-1101
USA

Product Catalog: H2TU-R-402-L7A

CLEI: VAR1JBZA

Document: LTPH-QI-1202-03



Technical Assistance

Tel: 800.366.3891 x73223
Tel: 952.917.3223
Fax: 952.917.3244
Email: wsd.support@adc.com

1269742

July 23, 2003