

## USER MANUAL



**H2TU-R-402 List 6E Remote Unit**  
Product: 1147790  
CLEI: VAR1AAAA

## Revision History of This Manual

To order copies of this document, use catalog number LTPH-UM-1106-02.

Issue	Release Date	Revisions Made
1	October 29, 2001	Initial release
2	May 24, 2002	Add local and line power jumper setting information.

## Copyright

May 24, 2002

©2002 ADC DSL Systems, Inc. All rights reserved.

## Trademark Information

ADC is a registered trademark of ADC Telecommunications, Inc.

HiGain is a registered trademark of ADC DSL Systems, Inc. No right, license, or interest to such trademarks is granted hereunder, and you agree that no such right, license, or interest shall be asserted by you with respect to such trademark.

Other product names mentioned in this practice are used for identification purposes only and may be trademarks or registered trademarks of their respective companies.

## Disclaimer of Liability

Information contained in this document is company private to ADC DSL Systems, Inc., and shall not be modified, used, copied, reproduced or disclosed in whole or in part without the written consent of ADC.

Contents herein are current as of the date of publication. ADC reserves the right to change the contents without prior notice. In no event shall ADC be liable for any damages resulting from loss of data, loss of use, or loss of profits, and ADC further disclaims any and all liability for indirect, incidental, special, consequential or other similar damages. This disclaimer of liability applies to all products, publications and services during and after the warranty period.

## USING THIS MANUAL

The following conventions are used in this manual:

- Monospace type indicates screen text.
- Keys you press are indicated by small icons such as **Y** or **ENTER**. Key combinations to be pressed simultaneously are indicated with a plus sign as follows: **CTRL** + **ESC**.
- Items you select are in **bold**.
- Three types of messages, identified by icons, appear in text.



**Notes contain information about special circumstances.**



**Cautions indicate the possibility of personal injury or equipment damage.**



**The Electrostatic Discharge (ESD) symbol indicates that a device or assembly is susceptible to damage from electrostatic discharge.**

For a list of abbreviations used in this document, refer to [“Appendix E - List of Abbreviations”](#) on page 39.

## INSPECTING SHIPMENT

Upon receipt of the equipment:

- Unpack each container and inspect the contents for signs of damage. If the equipment has been damaged in transit, immediately report the extent of damage to the transportation company and to ADC DSL Systems, Inc. Order replacement equipment, if necessary.
- Check the packing list to ensure complete and accurate shipment of each listed item. If the shipment is short or irregular, contact ADC DSL Systems, Inc. as described in [“Appendix D - Product Support”](#) on page 38. If you must store the equipment for a prolonged period, store the equipment in its original container.



# TABLE OF CONTENTS

<b>Overview</b>	<b>1</b>
Features .....	1
Compatibility .....	2
Applications .....	2
<b>Front Panel</b>	<b>3</b>
<b>Installation</b>	<b>5</b>
Verification .....	6
Verification without an H2TU-C Line Unit .....	6
Verification with an H2TU-C Line Unit .....	6
<b>Viewing System Screens</b>	<b>7</b>
Connecting to a Maintenance Terminal .....	7
Logon Screen .....	7
<b>Monitoring System Activity and Performance</b>	<b>10</b>
Using the Monitor Screen to View System Activity.....	10
Using the Performance Screens to View Performance Data.....	12
Performance History at the DS1 Interface.....	12
Performance History at the HDSL2 Interface .....	17
Using the Performance Screens to View Alarm Data.....	19
Alarm History at the DS1 Interface .....	19
Alarm History at the HDSL2 Interface.....	21
Using the System Event Log to Track Events .....	22
Using the Report Menu .....	24
<b>Loopback Operation</b>	<b>26</b>
Generic Loopback Commands .....	26
Special Loopback Commands .....	28
Loopback Test Procedures .....	28
GNLB Test Procedures.....	28
A2LB Test Procedures.....	30
A3LB and A4LB Test Procedures .....	32
SmartJack Test Procedure .....	32
<b>Appendix A - Specifications</b>	<b>33</b>
Loop Attenuation .....	34
H2TU-R-402 List 6E Card-Edge Connector .....	34
Craft Port.....	35
Local and Line Power.....	35

---

<b>Appendix B - Functional Operation</b>	<b>36</b>
Timing .....	36
<b>Appendix C - Compatibility</b>	<b>37</b>
<b>Appendix D - Product Support</b>	<b>38</b>
<b>Appendix E - List of Abbreviations</b>	<b>39</b>
<b>Certification and Warranty</b>	<b>Inside Back Cover</b>

## LIST OF FIGURES

1. H2TU-R-402 List 6E Front Panel .....	3
2. Installing the H2TU-R-402 List 6E .....	5
3. Logon Screen .....	8
4. Monitor Screen - Active Loopback with Alarms .....	10
5. H2TU-R DS1 31-Day Performance History .....	12
6. H2TU-C DS1 31-Day Performance History .....	13
7. H2TU-R DS1 48-Hour Performance History .....	13
8. H2TU-C DS1 48-Hour Performance History .....	14
9. H2TU-R DS1 25-Hour Performance History .....	14
10. H2TU-C DS1 25-Hour Performance History .....	15
11. H2TU-R DS1 Current Statistics .....	15
12. H2TU-R HDSL2 31-Day Performance History .....	17
13. H2TU-R HDSL2 48-Hour Performance History .....	17
14. H2TU-R HDSL2 25-Hour Performance History .....	18
15. H2TU-R HDSL2 Current Statistics .....	18
16. H2TU-R DS1 Alarm History Screen .....	19
17. H2TU-C DS1 Alarm History Screen .....	20
18. H2TU-R HDSL2 Alarm History Screen .....	21
19. H2TU-C HDSL2 Alarm History Screen .....	21
20. System Event Log .....	22
21. Report Menu - Full Report .....	24
22. Loopback Summary .....	26
23. Loopback Modes .....	29
24. H2TU-R-402 List 6E Card-Edge Connector .....	34
25. RS-232 Craft Port Pinouts .....	35
26. H2TU-R-402 List 6E Block Diagram .....	36

# LIST OF TABLES

- 1. Front-Panel Description ..... 4
- 2. Logon Screen Menus ..... 8
- 3. Navigational Keys for the HiGain Maintenance Terminal Screens..... 9
- 4. Monitor Screen Descriptions ..... 11
- 5. Error Acronyms Used on the DS1 Performance History Screens ..... 16
- 6. Error Acronyms Used on the HDSL2 Performance History Screens ..... 19
- 7. H2TU-R DS1 Alarm Descriptions..... 20
- 8. H2TU-R HDSL2 Alarm Descriptions ..... 22
- 9. Event Log Messages ..... 23
- 10. Report Types ..... 25
- 11. Summary of HiGain Loopback Codes and Activation Methods ..... 27
- 12. Addressable Repeater Loopback Commands (A2LB)..... 30
- 13. Addressable Repeater Loopback Commands (A3LB and A4LB)..... 32
- 14. SmartJack Loopup and Loopdown Commands ..... 32
- 15. HDSL2 Cable Attenuation Chart ..... 34



# OVERVIEW

The H2TU-R-402 List 6E remote unit is the customer premise side of a transmission system. The HiGain HDSL2 product family is fully compliant with the HDSL2 standard and ANSI T1/418. Providing full-rate T1 access using just a single copper pair, HDSL2 is a cost-effective solution that offers an open architecture. The open architecture inherent in HDSL2 guarantees interoperability, allowing simple and economic accommodation of network growth.

HiGain HDSL2 products provide 1.544 Mbps transmission on one unconditioned copper pair over the full Carrier Service Area (CSA) range. The CSA includes loops up to 12,000 feet of 24 American Wire Gauge (AWG) wire or 9,000 feet of 26 AWG wire, including bridged taps.



**The H2TU-R-402 List 6E complies with the protection switching features of the PSC-606 List 1 protection switching card. See the PSC-606 List 1 user manual, document number LTPH-UM-1006-xx for detailed information.**

## FEATURES

Features specific to the H2TU-R-402 List 6E include:

- Report menu option for downloading status and performance monitoring data to a file
- Enhanced loopback commands controlled by the LBK option that support
  - 100 inband loopdown command
  - 100000 (one in six) inband SMJK loopup command
- Sinks 10 mA of sealing current when connected to a compatible line unit

Standard features include:

- Line or locally powered with sealing current option
- Automatic Protection Switching (APS)
- HDSL2 transmission features
  - Lightning and power cross-protection on HDSL2 interfaces
  - Full-duplex HDSL2 transmission on one pair at 1.552 Mbps
  - Ultra-low wander (Stratum 1 compliant)
- Front-panel features
  - HDSL and DS1 status Light Emitting Diodes (LEDs)
  - Dual loopback control button
  - DS1 access bridging jacks
  - RS-232 craft port for connection to a maintenance terminal

- HiGain HDSL2 maintenance screens for inventory, provisioning, and troubleshooting
  - High-performance, non-volatile performance monitoring
  - Non-volatile alarm histories
  - Performance Report Messaging (PRM) support for Supplemental PRM (SPRM) and Network PRM (NPRM)
  - Payload (PL) and HiGain(HG) loopback source identification
- System configuration options
  - Selectable DS1 pre-equalizer
  - Power Back Off Customer (PBOC) and Power Back Off Network (PBON) options for configuring power output levels
  - Bipolar Violation Transparency (BPVT)
  - Bit Error Rate (BER) alarm
  - Remote provisioning
  - Selectable loopback activation codes
- Digital Data Service (DDS) latching loopback
- Line or local power with sealing current option
- Metallic loopback self tests



**DS1 is used throughout this document to refer to either the remote unit's DS1 interface or the line unit's DSX-1 interface.**

## COMPATIBILITY

The H2TU-R-402 List 6E is designed to mount in any 400 or 200 mechanics shelf. For a list of compatible shelves, see [“Appendix C - Compatibility” on page 37](#).

## APPLICATIONS

HiGain systems provide a cost-effective, easy-to-deploy method for delivering T1 High Capacity Digital Service (HCDS) over a single copper pair.

- The service is deployed over one unconditioned, non-loaded copper pair.
- Conventional inline T1 repeaters are no longer required.
- Cable pair conditioning, pair separation, and bridged tap removal are not required.

In general, HiGain systems:

- Operate effectively in the same cable binder group with other HDSL2 lines, HDSL, T1, ADSL, SDSL, POTS, DDS, and other transmission schemes.
- Can be used with customers requiring DS1 service on a temporary or permanent basis.
- Provide a means of quickly deploying service in advance of fiber-optic transmission systems.

# FRONT PANEL

Figure 1 shows the H2TU-R-402 List 6E front panel. Table 1 on page 4 describes the front-panel components. For pinout diagrams of the H2TU-R card-edge connector and craft port, refer to “Appendix A - Specifications” on page 33.

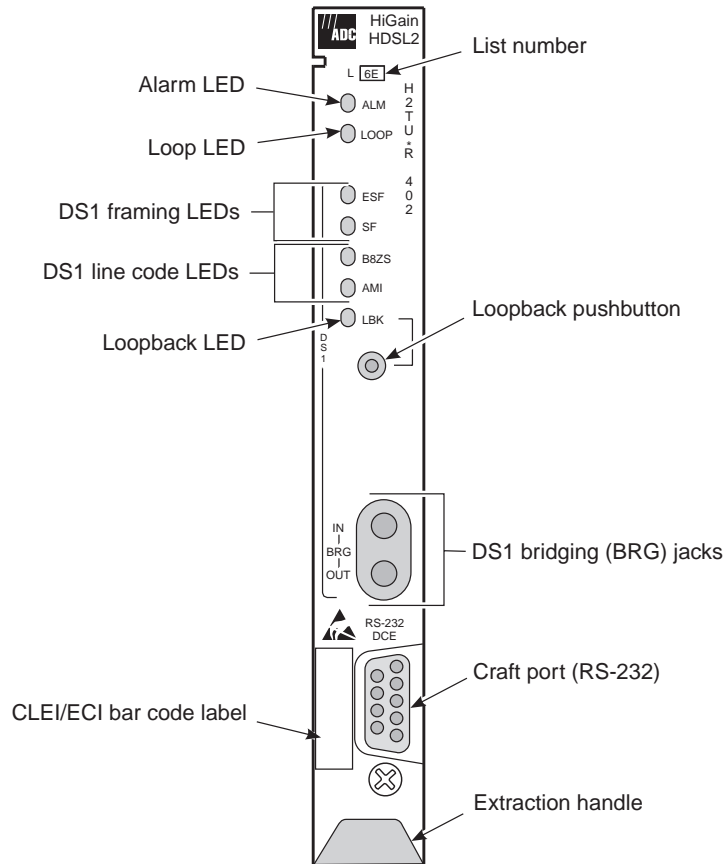

**Figure 1.** H2TU-R-402 List 6E Front Panel

**Table 1. Front-Panel Description**

<b>Front-Panel Feature</b>	<b>Function</b>
List number	Identifies the list number of the H2TU-R-402.
Alarm (ALM) LED	Shows alarm states for remote and local Loss of Signal (LOS).
Steady red	Indicates a Loss of Signal (LOS) condition at the T1 input of the H2TU-R.
Blinking	Indicates an LOS condition at the T1 input of the H2TU-C line unit.
Loop LED	Displays HDSL2 Loop condition.
Steady green	Indicates HDSL2 loop is in sync.
Blinking once per second	Indicates the HDSL2 loop is trying to acquire sync.
Blinking 4 times per second	Indicates a margin alarm condition on the HDSL2 loop.
Blinking 10 times per second	Indicates a Cyclic Redundancy Check (CRC) error on the HDSL2 loop.
OFF	Indicates no activity on the HDSL2 loop.
DS1 Framing LEDs (ESF and SF)	Indicates framing patterns. If DS1 signals are not detected, the ESF and SF LEDs will not light.
ESF LED = Steady green	Indicates Extended Super Frame (ESF). The LED blinks once per second when a frame error occurs.
SF LED = Steady green	Indicates Super Frame (SF). The LED blinks once per second when a frame error occurs.
OFF	Indicates unframed or no signal.
DS1 Line Code LEDs (B8ZS and AMI)	Indicates DS1 code options. If DS1 signals are not detected, the ESF, SF, B8ZS, and AMI LEDs will not light.
B8ZS LED = Steady green	Indicates that the DS1 line code option is set to Bipolar with 8-Zero Substitution (B8ZS). The LED blinks once per second when a string of excessive zeros is detected.
AMI LED = Steady green	Indicates that the user DS1 line code option is set to Alternate Mark Inversion (AMI). This LED blinks once per second when a Bipolar Violation (BPV) is detected.
Loopback (LPK) LED	Shows loopback states to and from the network and to and from the Customer Interface (CI).
Steady yellow	Indicates Network Remote (NREM) loopback, SmartJack (SMJK) loopback, or Transmit Loss of Signal (TLOS) loopback.
Blinking once per second	Indicates Customer Local Loopback (CLOC) loopback state.
Blinking 4 times per second	Indicates the H2TU-R is in an Armed state.
Loopback pushbutton	Activates or deactivates a dual loopback (NREM and CLOC) at the H2TU-R when the button is depressed for more than five (5) seconds.
DS1 bridging (BRG) jacks	Provides non-intrusive bridging jack access to (OUT) and from (IN) the HDSL2 span at the DS1 interface. Allows the DS1 payload to be monitored.
Craft port (RS-232)	Provides bidirectional communication between the unit and an external terminal to allow configuration and performance monitoring through the maintenance terminal screens.
CLEI and ECI bar code label	Provides the human-readable Common Language Equipment Identifier (CLEI) code number and the Equipment Catalog Item (ECI) bar code number.
Extraction handle	Used to remove the H2TU-R-402 from its card slot.

# INSTALLATION

- 1 Configure the H2TU-R for line or local power, as follows:
  - To configure the H2TU-R for line power, place a jumper on pins 2 and 3 of P2 and P3.
  - To configure the H2TU-R for local power, place a jumper on pins 1 and 2 of P2 and P3.
- 2 Check the setting of the SCURR jumper (P1). The default setting is disabled (jumper on pins 2 and 3). If the H2TU-R is locally powered and your application requires sealing current, place a jumper on pins 1 and 2.

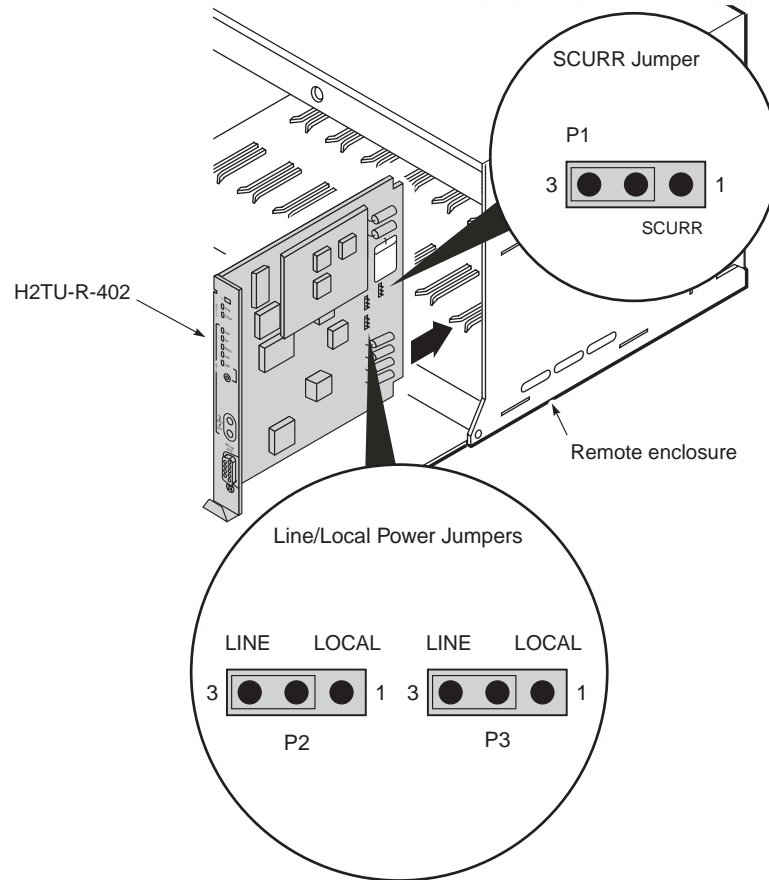

**Figure 2.** Installing the H2TU-R-402 List 6E



**Wear an antistatic wrist strap when installing the H2TU-R. Avoid touching components on the circuit board.**

- 3 Align the H2TU-R with the enclosure slot guides and slide the unit in. Push the unit back until it touches the backplane card-edge connector.
- 4 Place your thumbs on the front panel and push the H2TU-R into the card-edge connector.



When local power is applied to this unit, it automatically provides a resistive termination at its HDSL2 port. This termination sinks 10 mA of sealing current when connected to a list 4E or higher line unit.

## VERIFICATION

### Verification without an H2TU-C Line Unit

Verify that the H2TU-R powers up. The following should occur:

- The front-panel ALM LED is a steady red.
- The LOOP LED is flashing green.
- If receiving a DS1 signal, one of the DS1 framing LEDs (ESF or SF) and one of the DS1 line code LEDs (B8ZS or AMI) is a steady green.

### Verification with an H2TU-C Line Unit

- 1 Verify that the H2TU-R powers up.
  - The front-panel ALM LED is a steady red.
  - The LOOP LED is flashing green.
  - If receiving a DS1 signal, one of the DS1 framing LEDs (ESF or SF) and one of the DS1 line code LEDs (B8ZS or AMI) is a steady green.
- 2 Verify that the H2TU-R attempts to communicate with the line unit (LOOP LED is flashing green). One of the following occurs:
  - If an upstream device is successfully identified and the HDSL2 loop synchronizes, the LOOP LED lights a steady green.
  - If the line unit is not successfully identified, the H2TU-R continues to attempt communication (LOOP LED flashes green) until a line unit is detected.

# VIEWING SYSTEM SCREENS

The H2TU-R-402 supports both local and remote logon through a maintenance terminal (ASCII terminal or PC running terminal emulation software) connected to its front-panel craft port.

From the maintenance terminal you can access menus and screens that are replications of those viewed at the H2TU-C. You can view system settings and inventory, initiate loopbacks, and monitor performance. If the Remote Provisioning option is enabled at the H2TU-C, you can configure the circuit.



**Initial provisioning of the HiGain HDSL2 system is performed at the H2TU-C line unit. For more information about the HiGain screens, provisioning, and troubleshooting, contact Customer Service to obtain a copy of the applicable user manual (see “Appendix D - Product Support” on page 38).**

## CONNECTING TO A MAINTENANCE TERMINAL

To connect to a maintenance terminal:

- 1 Connect a standard 9-pin serial cable to the RS-232 craft port (Figure 1 on page 3) on the H2TU-R-402 List 6E front panel.
- 2 Connect the other end of the cable to the serial port on the maintenance terminal.
- 3 Start a terminal emulation program such as Procomm (emulating a VT100 terminal).
- 4 Configure the maintenance terminal to the following communication settings:
  - 9600 baud
  - No parity
  - 8 data bits
  - 1 stop bit
  - Hardware flow control to OFF
- 5 If necessary, press **CTRL** + **R** to refresh the HiGain HDSL2 logon screen.

## LOGON SCREEN

The maintenance terminal screens allow you to monitor, provision, and troubleshoot the HiGain HDSL2 system.

To select a menu from the HiGain HDSL2 logon screen (Figure 3 on page 8), do one of the following:

- Press the first letter of the menu.
- Use the **←** **→** arrow keys to select the menu, and then press **ENTER**.

Table 2 on page 8 describes the Logon screen menus. Table 3 on page 9 summarizes the navigational keys. The navigational keys are also listed in the onscreen Help menu.



**Most VT100 emulation programs support a print screen option. For Windows-based programs, such as Procomm or HyperTerminal, see the Help menu for instructions.**

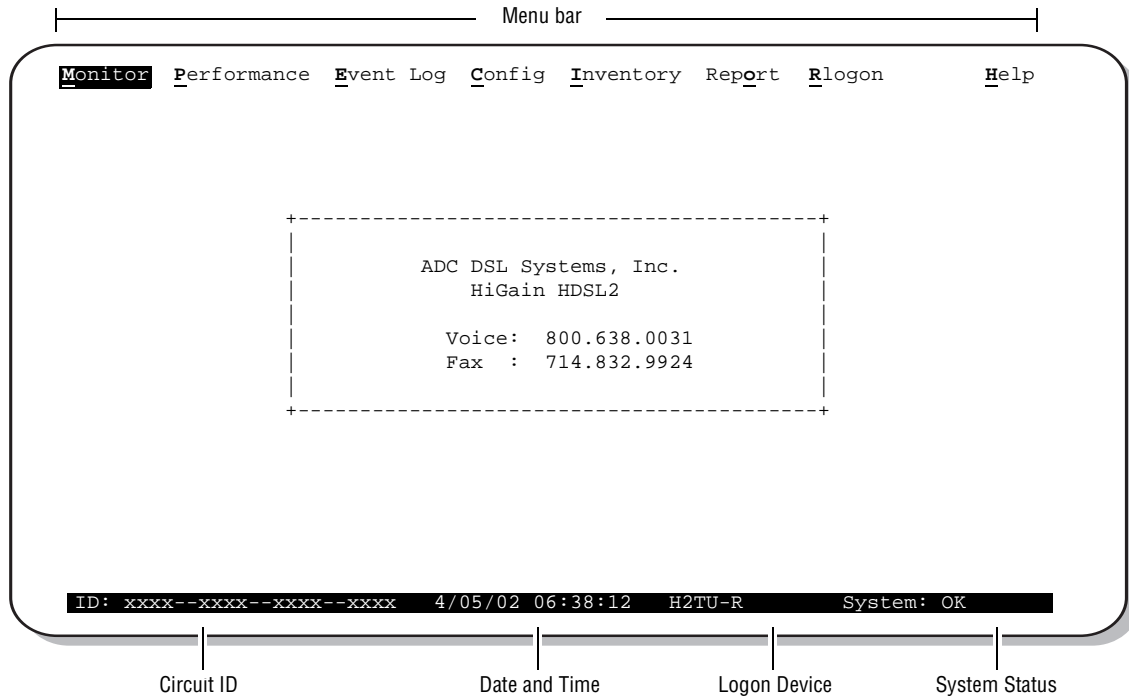

Figure 3. Logon Screen

Table 2. Logon Screen Menus

Press this key	To access this menu	Menu Functions
<b>M</b>	Monitor	Monitors loopbacks and alarms, and provides a graphical representation of circuit activity, including ES, UAS, SES, and line code.
<b>P</b>	Performance	Provides performance and alarm histories for current, 25-hour, 48-hour, or 31-day periods for either the DS1 or HDSL2 interface.
<b>E</b>	Event Log	Identifies the 100 most recent system events and reports the date and time of occurrence.
<b>C</b>	Config	Provides standard configuration options, ADC options, date and time setting, and a reset option (factory settings).
<b>I</b>	Inventory	Provides product information about the various devices that are in the system and lists circuit and device identifications.
<b>O</b>	Report	Provides screens containing status and performance monitoring data for line and remote units which can be downloaded to a file.
<b>R</b>	Rlogon / Rlogout	Remote log on can be performed from the H2TU-R or H2TU-C. The screen displays " <b>R</b> logout" when the H2TU-R or H2TU-C is remotely logged on to the other unit at the end of the circuit. To log off the remote unit, press <b>R</b> . " <b>R</b> logout" changes to " <b>R</b> logon". The unit is now locally logged on until <b>R</b> is pressed again to re-initiate the remote log on.
<b>H</b>	Help	Provides a glossary of terms used in the maintenance screens, a list of navigational keys, and ADC contact information.



**Table 3.** *Navigational Keys for the HiGain Maintenance Terminal Screens*

<b>Key <sup>(a)</sup></b>	<b>Function</b>
<b>SPACEBAR</b>	Cycle through selections.
<b>ENTER</b>	Activate the current setting or choice, or display a menu.
<b>ESC</b> or <b>F11</b> (VT100)	Return to the parent menu.
<b>↑</b> or <b>CTRL + E</b>	Select the submenu or item above the current one, or return to the previous menu.
<b>↓</b> or <b>CTRL + X</b>	Select the submenu or item below the current one.
<b>→</b> or <b>CTRL + D</b>	Select the menu or item to the right of the current one.
<b>←</b> or <b>CTRL + S</b>	Select the menu or item to the left of the current one, or return to the previous menu.
<b>CTRL + R</b>	Refresh the screen.

(a) Legacy management units require use of control keys instead of arrow keys.



- 3 To initiate a loopdown of all active loopbacks, press the **SPACEBAR** to select **LPDN**, then press **ENTER** or **N**. When prompted with the message: Are you sure (Y/N)?, press **Y** to initiate the loopdown or **N** to cancel.

**Table 4. Monitor Screen Descriptions**

Field	Description
Active Loopback	An active loopback is indicated on the lower third of the Monitor screen. Available loopbacks are indicated by gray text. See <a href="#">Table 11 on page 27</a> for a summary of the HiGain loopback codes and activation methods.
Alarm type	Indicates type of alarm.
Armed mode	Indicates system is in an armed state for an intelligent repeater loopback command.
Code type	Type of DS1 line coding used (B8ZS or AMI).
DS1 ES Count	Errored Seconds—The sum of the Errored Seconds-Line (ES-L) and Errored Seconds-Path (ES-P) counts detected on the DS1 input over a 24-hour period. Errors included are: DS1 Frame errors, BPV, and ESF CRC errors.
DS1 SES Count	Severely Errored Seconds—The sum of the DS1 Severely Errored Seconds-Line (SES-L) and Severely Errored Seconds-Path (SES-P) counts over the last 24 hours.
DS1 UAS Count	Unavailable Errored Seconds—The number of seconds during which the DS1 input signal was absent over a 24-hour period.
Frame type	Type of DS1 framing used on the input stream (SF, ESF or UNFR).
HDSL2 ES Count	Errored Seconds—The number of 1-second intervals that contained at least one CRC or LOSW error. This value is a running total of the last 24 Hours.
HDSL2 SES Count	Severely Errored Seconds—The number of 1-second intervals that contain at least 50 CRC errors or one or more LOSW defects. (An LOSW defect occurs when at least three consecutive HDSL frames contain one or more frame bit errors.) This value is a running total of the last 24 hours.
HDSL2 UAS Count	Unavailable Errored Seconds—The number of seconds the HDSL2 loop is unavailable. This occurs after 10 contiguous HDSL SES and is retired after 10 contiguous non-SES seconds. This value is a running total of the last 24 hours.
ID	Circuit identification (ID) number.
LA	Loop Attenuation—indicates the attenuation of the Overlapped Pulse Amplitude Modulation Transmission with Interlocking Spectra (OPTIS) pulse from the distant end. The value is related to the 196 kHz loss of the cable pair. The loop attenuation is a more direct indication of the loop attenuation to the OPTIS signal than is the 196 kHz loss. The normal HiGain LA operation range is from 0 to 40 dB.
LPF	Line Power Feed—indicates the HDSL2 line power is on.
M	Margin—the signal-to-noise ratio at all HDSL2 ports, relative to a 10 <sup>-7</sup> Bit Error Rate.
MAL	Margin Alarm—Indicates the margin on HDSL2 loop has dropped below the threshold (0 to 15dB) as set by the operator.
PL (or HG)	PL displays when the loopback was initiated by a command embedded in the DS1 data path payload (PL). HG displays when the loopback was initiated from a HiGain (HG) front panel or by a HiGain maintenance terminal loopback command.
PRM	The sum of the Performance Report Messaging-Near End (PRM-NE) and Performance Report Messaging-Far End (PRM-FE) counts.
System Status	The presence or absence of alarms (BER, MARG, LOS, AIS, AIS-CI, RAI, RAI-CI, LA) is indicated on the lower right corner of all screens.

# USING THE PERFORMANCE SCREENS TO VIEW PERFORMANCE DATA

To access the Performance history screens:

- 1 Press **P** to select the Performance screen.
- 2 Press the **SPACEBAR** to select either interface (**H2TU-C DS1**, **H2TU-R DS1**, **H2TU-C HDSL2**, or **H2TU-R HDSL2**), then press **ENTER**.
- 3 Press the **SPACEBAR** to select the type of statistics (**Current**, **Alarm History**, **25-Hour History**, **48-Hour History**, or **31-Day History**), then press **ENTER**.



Performance screens for the H2TU-C are shown only when they are different from the H2TU-R screens.

## Performance History at the DS1 Interface

Figure 5 is an example of a 31-Day History screen for the H2TU-R DS1 interface. The DS1 interface provides 31-day, 48-hour, 25-hour, and current statistics screens for the H2TU-R and the H2TU-C. Table 5 on page 16 describes the kinds of errors reported for these screens.

```

Monitor  Performance  Event Log  Config  Inventory  Report  Rlogon      Help
-----
                H2TU-R DS1   31 Day History (Page 1 of 3)
-----
Date      CV-L   ES-L   SES-L   UAS-L   PDVS-L   ES-P   SES-P   UAS-P   PRM-NE   PRM-FE
-----
03/24      -     -     -     -     -     -     -     -     -     -
03/25      -     -     -     -     -     -     -     -     -     -
03/26      -     -     -     -     -     -     -     -     -     -
03/27      -     -     -     -     -     -     -     -     -     -
03/28      -     -     -     -     -     -     -     -     -     -
03/29      -     -     -     -     -     -     -     -     -     -
03/30      -     -     -     -     -     -     -     -     -     -
03/31      -     -     -     -     -     -     -     -     -     -
04/01      -     -     -     -     -     -     -     -     -     -
04/02      -     -     -     -     -     -     -     -     -     -
04/03      14    10    10    12     10    10     0     0     0     0
04/04       0     0     0     2      0     0     0     0     0     0
-----
                Press: (N)ext Page, (P)revious Page, C(l)ear History
-----
Use <Space> to cycle through choices and <Enter> to view
ID: xxxx--xxxx--xxxx--xxxx  Interface : H2TU-R DS1
                               Statistics : 31 Day History
                               4/05/02 07:05:33 H2TU-R System: OK
    
```

Figure 5. H2TU-R DS1 31-Day Performance History

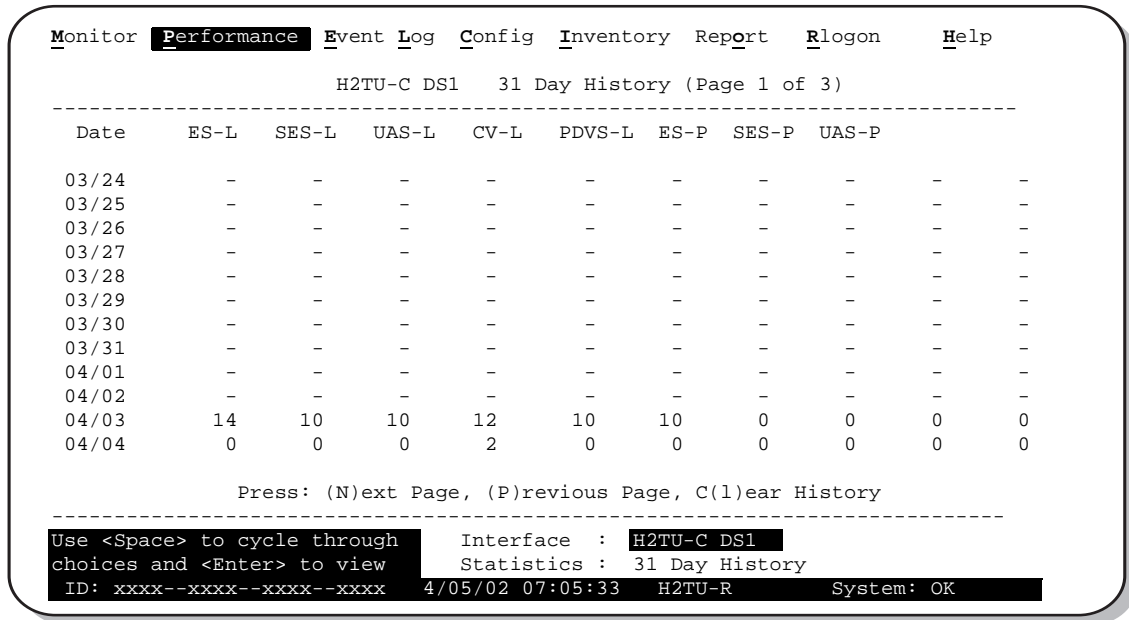

Figure 6. H2TU-C DS1 31-Day Performance History

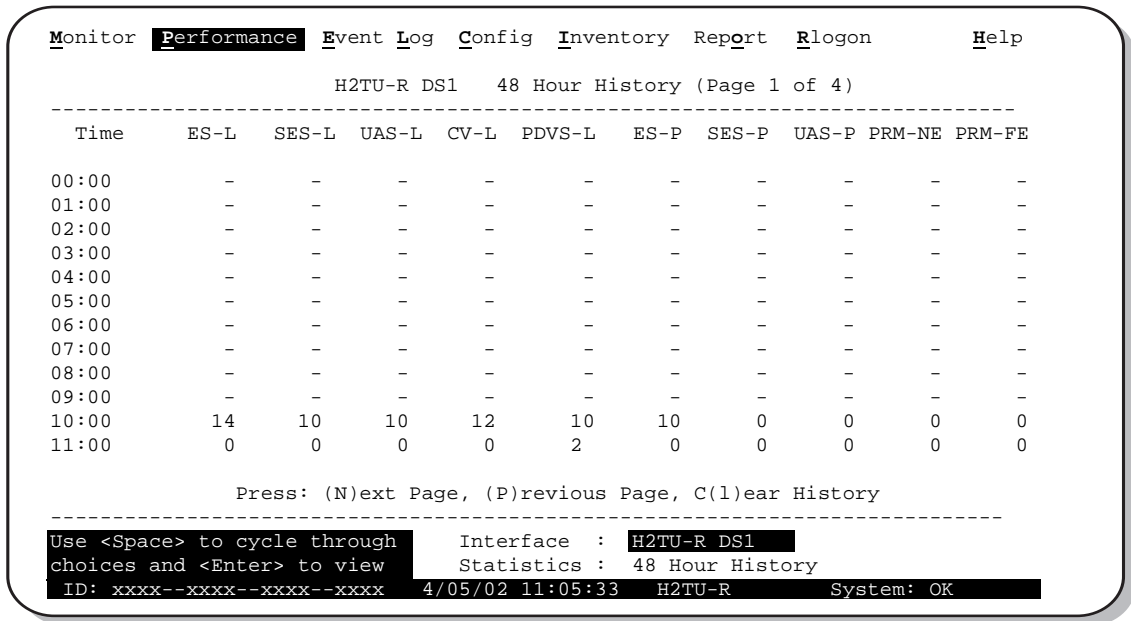

Figure 7. H2TU-R DS1 48-Hour Performance History

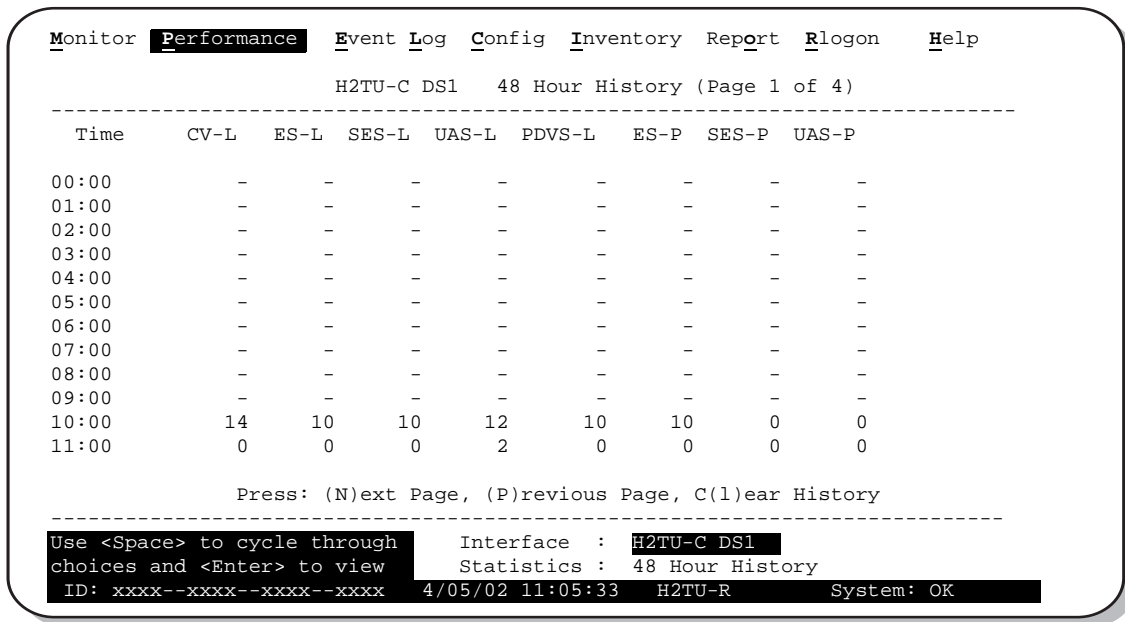

Figure 8. H2TU-C DS1 48-Hour Performance History

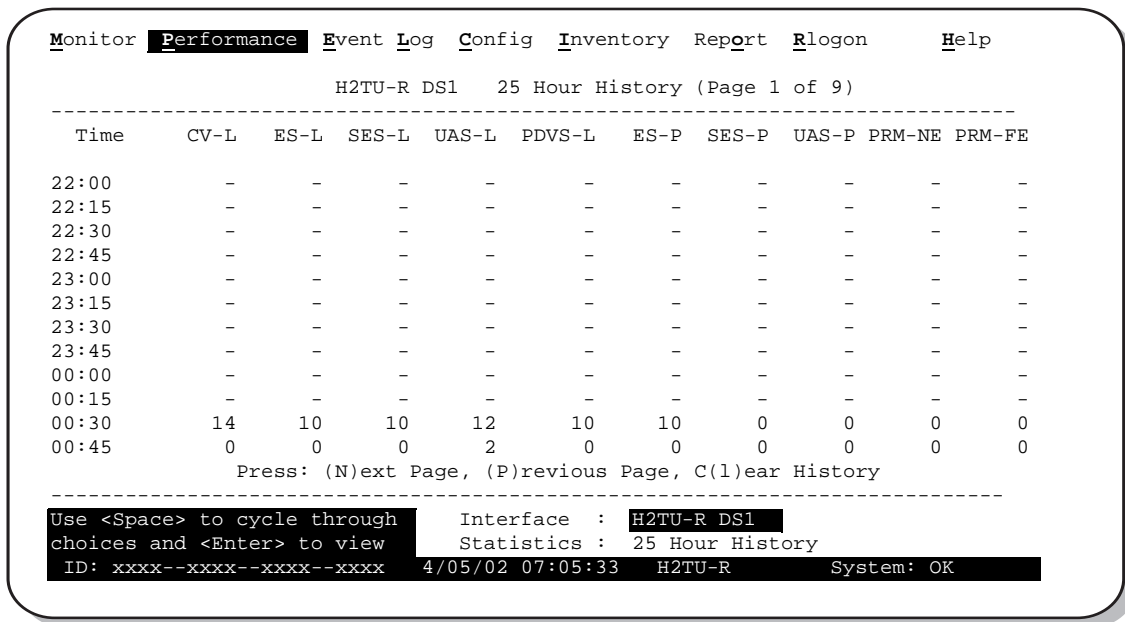
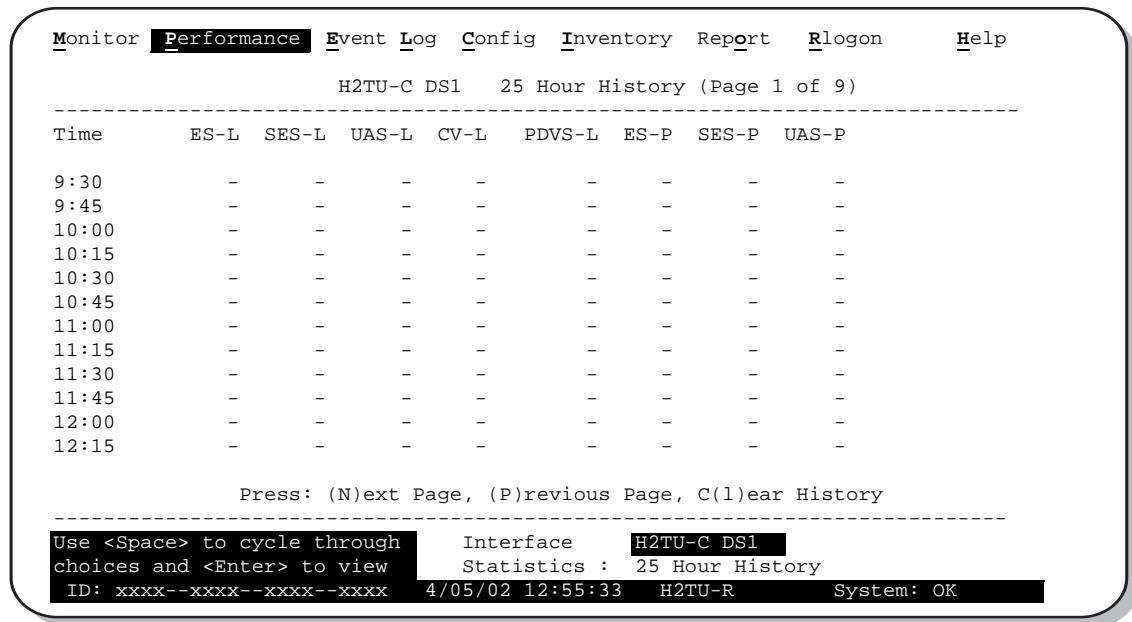
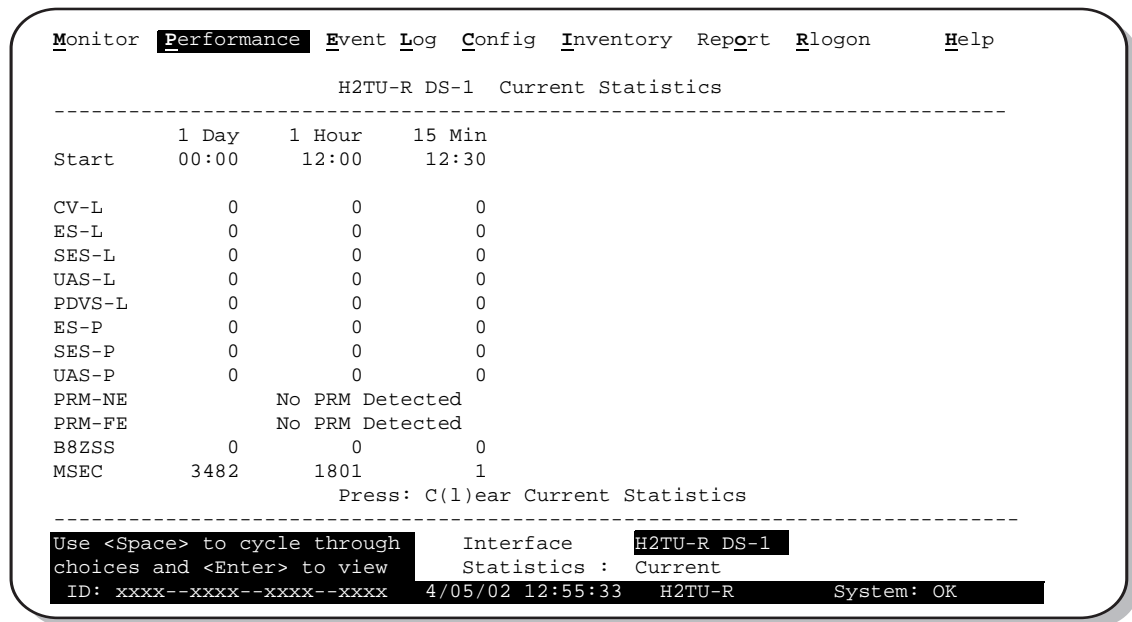

Figure 9. H2TU-R DS1 25-Hour Performance History



*Figure 10. H2TU-C DS1 25-Hour Performance History*



*Figure 11. H2TU-R DS1 Current Statistics*

**Table 5.** Error Acronyms Used on the DS1 Performance History Screens

Error Acronym	Description	Error Acronym	Description
ES-L	Errored Seconds - Line Seconds with BPV $\geq 1$ .	SES-P	Severely errored seconds - Path Seconds with SES or CRC(ESF) $\geq 320$ or FE <sup>(d)</sup> (SF) $\geq 8$ ( $F_T + F_S$ ).
SES-L	Severely errored seconds - Line Seconds with BPV plus EXZ $\geq 1544$ or LOS $\geq 1$ .	UAS-P	Unavailable seconds - Path A second of unavailability based on SES-P or AIS $\geq 1$ .
UAS-L	Unavailable seconds - Line Seconds with LOS $\geq 1$ .	PRM-NE <sup>(a)</sup>	Performance Report Monitoring - Near End The PRM from CPE indicates errors, and the signal received from the network at the remote is error-free.
CV-L	Code Violation - Line Total BPV count.	PRM-FE <sup>(a)</sup>	Performance Report Monitoring - Far End The PRM from the network indicates errors, and the signal received from the CPE is error-free.
PDVS-L	Pulse Density Violation Seconds - Line Seconds with excessive zeroes (AMI = 16 zeroes, B8ZS = 8 zeroes).	B8ZSS <sup>(b)</sup>	B8ZS Monitored Seconds Seconds with B8ZS detection when AMI option is active.
ES-P	Errored Seconds - Path Seconds with SEF <sup>(c)</sup> , CRC (ESF) or FE <sup>(d)</sup> (SF) $\geq 1$ .	MSEC <sup>(b)</sup>	Monitored Seconds of the current (15-minute/1-hour/1-day) screen.

(a) Only appears on H2TU-R Performance History screens.

(b) Appears on the DS1 Current Statistics screens.

(c) Severely Errored Frame—Two or more frame bit errors occurring in a 0.75 ms interval for SF or a 3 ms interval for ESF.

(d) FE is a frame bit error.



## Performance History at the HDSL2 Interface

Figure 12 is an example of a 31-Day History screen for the H2TU-R HDSL2 interface. The HDSL2 interface has 31-day, 48-hour, 25-hour, and current statistics screens for the H2TU-R and H2TU-C. Table 6 on page 19 describes the kinds of errors reported for these screens.

```

Monitor  Performance  Event Log  Config  Inventory  Report  Rlogon  Help
-----
                H2TU-R HDSL2 31 Day History (Page 1 of 3)
-----
Date      ES      SES      UAS      CV      LOSWS
-----
03/23     -      -      -      -      -
03/24     -      -      -      -      -
03/26     -      -      -      -      -
03/27     -      -      -      -      -
03/28     -      -      -      -      -
03/29     -      -      -      -      -
03/30     -      -      -      -      -
03/31     -      -      -      -      -
04/01     -      -      -      -      -
04/02     -      -      -      -      -
04/03     -      -      -      -      -
04/04     14     10     14     10     10

Press: (N)ext Page, (P)revious Page, C(l)ear History
-----
Use <Space> to cycle through      Interface : H2TU-R1 HDSL2
choices and <Enter> to view      Statistics : 31 Day History
ID: xxxx--xxxx--xxxx--xxxx      4/05/02 07:05:33  H2TU-R      System: OK

```

Figure 12. H2TU-R HDSL2 31-Day Performance History

```

Monitor  Performance  Event Log  Config  Inventory  Report  Rlogon  Help
-----
                H2TU-R HDSL2 48 Hour History (Page 1 of 4)
-----
Time      ES      SES      UAS      CV      LOSWS
-----
1:00     -      -      -      -      -
02:00     -      -      -      -      -
03:00     -      -      -      -      -
04:00     -      -      -      -      -
05:00     -      -      -      -      -
06:00     -      -      -      -      -
07:00     -      -      -      -      -
08:00     -      -      -      -      -
09:00     -      -      -      -      -
10:00     -      -      -      -      -
11:00     -      -      -      -      -
12:00     -      -      -      -      -

Press: (N)ext Page, (P)revious Page, C(l)ear History
-----
Use <Space> to cycle through      Interface : H2TU-R HDSL2
choices and <Enter> to view      Statistics : 48 Hour History
ID: xxxx--xxxx--xxxx--xxxx      4/05/02 12:55:33  H2TU-R      System: OK

```

Figure 13. H2TU-R HDSL2 48-Hour Performance History

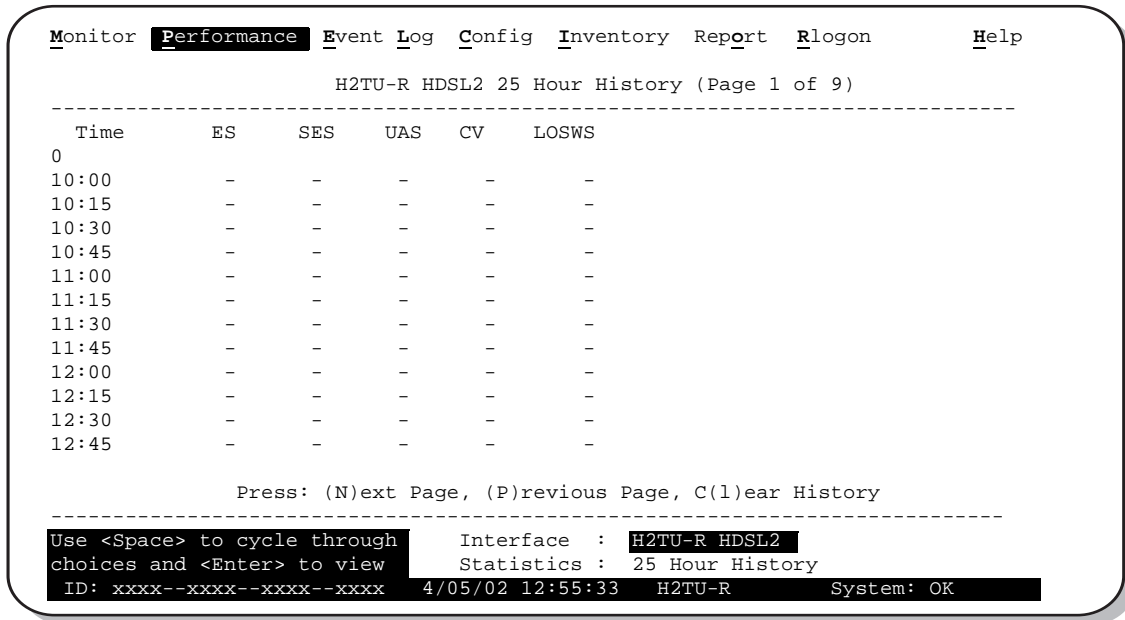

Figure 14. H2TU-R HDSL2 25-Hour Performance History

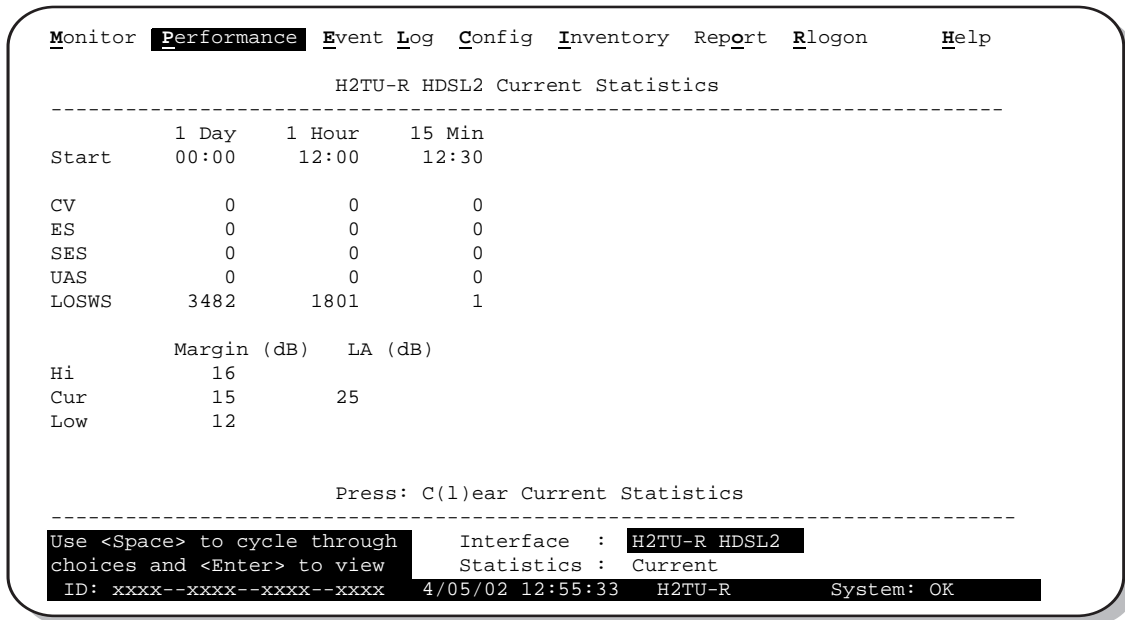

Figure 15. H2TU-R HDSL2 Current Statistics

**Table 6.** Error Acronyms Used on the HDSL2 Performance History Screens

Error Acronym	Description
ES	Errored seconds Seconds with HDSL2 CRC $\geq 1$ or LOSW $\geq 1$
SES	Severely errored seconds Seconds with HDSL2 CRC $\geq 50$ or LOSW $\geq 1$
UAS	Unavailable seconds Based on 10 contiguous SES occurrences
CV	Code Violation Total count of HDSL2 CRC errors.
LOSWS	Loss of Sync Word Second Seconds with LOSW $\geq 1$

## USING THE PERFORMANCE SCREENS TO VIEW ALARM DATA

To access the alarm history screens:

- 1 Press **P** to select the Performance menu.
- 2 Press the **SPACEBAR** to select an interface (**H2TU-C DS1**, **H2TU-R DS1**, **H2TU-C HDSL2**, or **H2TU-R HDSL2**), then press **ENTER**.
- 3 Press the **SPACEBAR** until **Alarm History** is selected, then press **ENTER**.
- 4 Press **N** or **P** to page through the alarm history screens.
- 5 Press **L** to clear the selected alarm history screen.

### Alarm History at the DS1 Interface

Figure 16 below and Figure 17 on page 20 are examples of Alarm History screens for the H2TU-R DS1 interface and the H2TU-C DS1 interface, respectively. Current alarms are shown in reverse video. The types of alarms reported for the H2TU-R are described in Table 7 on page 20.

```

Monitor  Performance Event Log Config Inventory Report Rlogon Help
-----
                H2TU-R DS-1 Alarm History
-----
Alarm      First          Last          Status      Count
RLOS      3/27/02 00:00    4/04/02 00:45    ALARM
RAIS
RAI
TX RAI-CI
PRM-NE
PRM-FE
DBER      3/27/02 00:00    4/04/02 00:47    OK
                                         7

Press: C(l)ear Alarm History
-----
Use <Space> to cycle through      Interface : H2TU-R DS-1
choices and <Enter> to view      Statistics : Alarm History
ID: xxxx--xxxx--xxxx--xxxx    4/05/02 07:05:33    H2TU-R    System: Alarm

```

**Figure 16.** H2TU-R DS1 Alarm History Screen

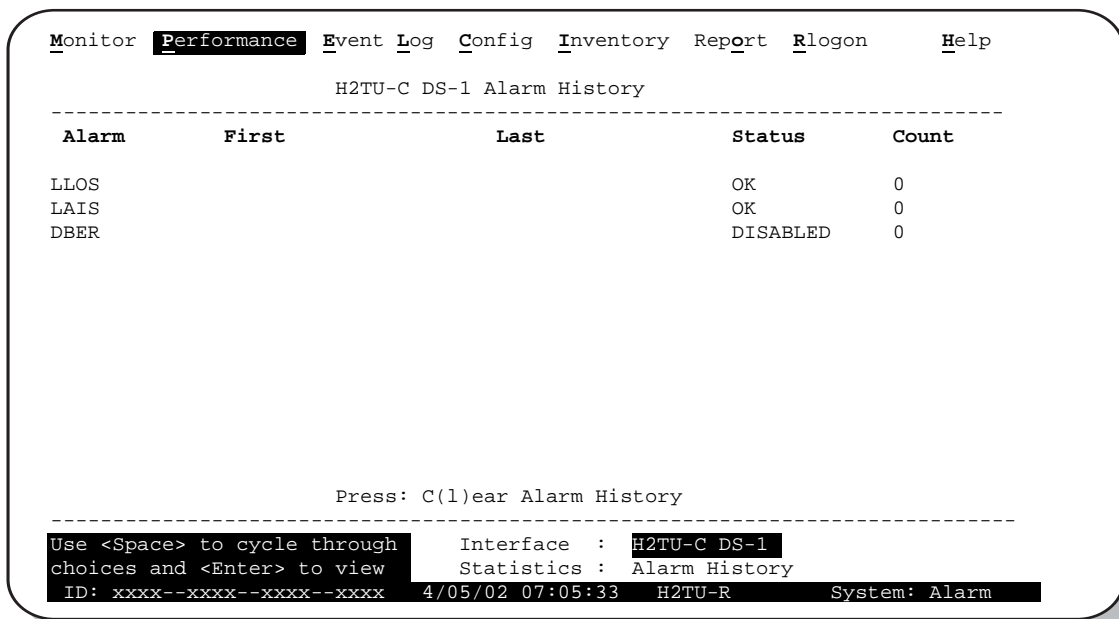

Figure 17. H2TU-C DS1 Alarm History Screen

Table 7. H2TU-R DS1 Alarm Descriptions

Screen Alarm	Front-Panel Alarm	Description
RLOS	RLOS	Remote Loss of Signal— Loss of the H2TU-R DS1 input signal.
RAIS	RAIS	Remote Alarm Indication Signal—Indicates an AIS (all ones) pattern is being received at the H2TU-R DS1 input port. By default AIS-CI <sup>(a)</sup> is sent towards the network.
RAI	RRAI	Remote RAI - Remote Alarm Indication at the H2TU-R—Indicates an RAI alarm (yellow) from the CPE with errors from the line unit or network.
TX RAI-CI	TRCI	Transmit RAI-CI - Remote Alarm Indication at the H2TU-R—Upon reception of an RAI (yellow alarm) from the CPE, the H2TU-R sends a RAI-CI towards the network if the network signal received at the H2TU-R is clear. If the network signal is impaired (LOS, AIS or LOF), then the RAI is passed on to the network unaltered. This is applicable to SF or ESF framing. In an all SF environment, RACI must be enabled to convert SF RAI to SF RAI-CI.
PRM-NE	PRMN	Performance Report Monitoring - Near End—The count of the PRM-NE register at the H2TU-R exceeds the 10 <sup>-6</sup> BER threshold at 648 events since 12:00:00 AM.
PRM-FE	PRMF	Performance Report Monitoring - Far End—The count of the PRM-FE register at the H2TU-R exceeds the 10 <sup>-6</sup> BER threshold at 648 events since 12:00:00 AM.
DBER	DBER	Bit Error Rate—The DS1 BER has exceeded the built-in 24-hour threshold limits of approximately 10 <sup>-6</sup> .

(a) AIS-CI is a modified AIS alarm pattern. Equipment not suited to detect AIS-CI still detects this signal as an AIS. AIS-CI is sent toward the network indicating that an LOS (RLOS) or AIS (RAIS) has been received from the CPE.

## Alarm History at the HDSL2 Interface

Figure 18 and Figure 19 are examples of Alarm History screens for the H2TU-R HDSL2 interface and the H2TU-C HDSL2 interface, respectively. Current alarms are shown in reverse video. The types of alarms reported for the H2TU-R are described in Table 8 on page 22.

```

Monitor  Performance  Event Log  Config  Inventory  Report  Rlogon  Help
-----
                H2TU-R HDSL2 Alarm History
-----
Alarm      First              Last              Status          Count
-----
LOS        LOSW                OK                0
MAL        MAL                 OK                0
LA         LA                  OK                0
HBER       03/16/02 00:37     04/04/02 00:45   OK                7

                Press: C(1)ear Alarm History
-----
Use <Space> to cycle through      Interface : H2TU-R HDLS2
choices and <Enter> to view       Statistics : Alarm History
ID: xxxx--xxxx--xxxx--xxxx      4/05/02 07:05:33  H2TU-R          System: Alarm

```

Figure 18. H2TU-R HDSL2 Alarm History Screen

```

Monitor  Performance  Event Log  Config  Inventory  Report  Rlogon  Help
-----
                H2TU-C HDSL2 Alarm History
-----
Alarm      First              Last              Status          Count
-----
LOS        LOSW                OK                0
MAL        MAL                 OK                0
LA         LA                  OK                0
HBER       03/16/02 00:37     04/04/02 00:45   OK                7
SHORT      SHORT               OK                0
GND        GND                 OK                0
OPEN       OPEN                OK                0

                Press: C(1)ear Alarm History
-----
Use <Space> to cycle through      Interface : H2TU-C HDLS2
choices and <Enter> to view       Statistics : Alarm History
ID: xxxx--xxxx--xxxx--xxxx      4/05/02 07:05:33  H2TU-R          System: Alarm

```

Figure 19. H2TU-C HDSL2 Alarm History Screen

**Table 8.** H2TU-R HDSL2 Alarm Descriptions

Screen Alarm	Front-Panel Alarm	Description
LOSW	LOSW	Loss of Sync Word—The HDSL2 loop has lost synchronization.
MAL	MAL	Margin—The margin on the HDSL2 loop has dropped below the minimum threshold value set for the system.
LA	LA	Loop Attenuation—The attenuation on the HDSL2 loop has exceeded the maximum value set for the HDSL2 loop attenuation threshold.
HBER	HBER	Block Error Rate—The HDSL2 BER has exceeded the set threshold limits of $10^{-6}$ or $10^{-7}$ .

## USING THE SYSTEM EVENT LOG TO TRACK EVENTS

To view a running log of system events, press **E** to select the Event Log. The Event Log displays the date and time of the 100 most recent events (most recent displayed first) and provides a description of each event. See [Table 9 on page 23](#) for a complete list of event log messages.

- Press **N** or **P** to page through the event log.
- Press **T** to return to the top of the log.
- Press **L** to clear the event log.

```

Monitor Performance Event Log Config Inventory Report Rlogon Help
-----
System Event Log (Page 1 of 7)
-----
# Origin          Date and Time      Entry
1 System          03/23/01 12:25:00  DS1 Alarm Register reset
2 System          03/24/01 12:25:00  HDSL2 Alarm Register Reset
3 System          03/25/01 12:25:00  DS1 Performance Register Reset
4 System          03/26/01 12:25:00  HDSL2 Performance Register Reset
5 System          03/27/01 00:13:32  Time set 12:25:00
6 System          03/28/01 00:13:27  Date set 10/21/00
7 H2TU-C          03/29/01 00:13:27  NLOC: Loop-down
8 H2TU-C          03/30/01 00:11:16  NLOC: Loop-up
9 H2TU-R          03/31/01 00:10:43  DS1 LOS Alarm: End
10 H2TU-R         04/01/01 00:10:30  DS1 LOS Alarm: Begin
11 System         04/02/01 00:04:11  DS1C: AUTO to AMI
12 H2TU-C         04/03/01 00:00:40  HDSL2 LOSW Alarm: End
13 H2TU-C         04/04/01 00:00:02  HDSL2 LOSW Alarm: Begin
14 - EMPTY -
15 - EMPTY -

Press: (N)ext Page, (P)revious Page, (T)op of Log, C(l)ear Log
ID: xxxx--xxxx--xxxx--xxxx 4/05/02 07:07:54 H2TU-R System: OK

```

**Figure 20.** System Event Log

**Table 9. Event Log Messages**

<b>Event Log Messages</b>
DS1 Alarm History reset
DS1 PM register reset
HDSL2 Alarm History reset
HDSL2 PM register reset
Loop Down (any segment)
Loop Up (any segment)
Provisioning option change: <provisioning mnemonic>: changed from <old> to <new>
CPE DBER alarm (1-day threshold crossed of any PM data except PRM-NE or PRM-FE)
CPE DS1 AIS begins/ends
CPE DS1 LOS begins/ends
CPE PRM-NE BER alarm (at the remote only 1-day threshold crossed of PRM-NE trouble on CPE receive)
Current statistics reset
Event Log reset
H2TU-C Power up/down
H2TU-R Power up/down
HDSL2 DC pair open begins/ends on any segment
HDSL2 Ground fault begins/ends on any segment
HDSL2 HBER alarm (threshold crossed) on any segment.
HDSL2 loop attenuation (threshold crossed) on any HDSL2 I/F
HDSL2 margin alarm (threshold crossed) on any HDSL2 I/F
HDSL2 unavailability begins/ends on any segment
Master zero reset
NTWK DBER alarm (1-day threshold crossed of any PM data)
NTWK DS1 LOS begins/ends
NTWK PRM-FE BER alarm (at the remote only: 1-day threshold crossed of PRM-FE: trouble on NTWK far end)
NTWN DS1 AIS begins/ends
Power Feed Open begins/ends
Power Feed Short begins/ends
RAI begins/ends
TX RAI-CI begins/ends (RAI-CI sent from the remote towards the network)

## USING THE REPORT MENU

The Report menu (Figure 21) provides screens containing status and performance monitoring data for line and remote units which can be downloaded to a file for analysis or future reference. Table 10 on page 25 describes the four types of reports provided by the Report menu.

To select each individual report, do the following:

- 1 Press **O** to select Report menu.
- 2 Press the **SPACEBAR** to select a report.
- 3 Use your terminal emulation software (HyperTerminal or Procomm) to capture the selected report to your printer or to a file. Press **ENTER** to generate.
- 4 End the captured report.
- 5 Press **CTRL + R** to refresh the Report menu screen.



Figure 21. Report Menu - Full Report



**Table 10. Report Types**

<b>Type</b>	<b>Contains the following information:</b>
Full Report	<ul style="list-style-type: none"><li>• Circuit and unit identifications</li><li>• Product information</li><li>• System configuration</li><li>• Current performance statistics</li><li>• Alarm history</li><li>• Performance history</li><li>• System event log</li></ul>
Short Report	<ul style="list-style-type: none"><li>• Product information</li><li>• System configuration</li><li>• Current performance statistics</li><li>• Circuit and unit identification</li></ul>
System Information Report	<ul style="list-style-type: none"><li>• Circuit and unit identifications</li><li>• Product information</li><li>• System configuration</li></ul>
Event Report	<ul style="list-style-type: none"><li>• Circuit and unit identifications</li><li>• Product information</li><li>• System event log</li></ul>

# LOOPBACK OPERATION

HiGain has a family of loopback options for analyzing circuit functionality. The loopback signal is transmitted and returned to the sending device for comparison. This allows you to verify the integrity of the HDSL2 channels to the H2TU-C, the H2TU-C DSX-1 interface, and the DS1 channels to the customer. Loopback options include:

- Generic Loopback (GNLB) options, including the SmartJack (SMJK) option (see [Table 11 on page 27](#))
- Special Loopback (SPLB) options (see “[Special Loopback Commands](#)” on page 28) and the following command tables:
  - Addressable Repeater Loopback command: A2LB (see [Table 12 on page 30](#))
  - Addressable Repeater Loopback commands: A3LB, A4LB (see [Table 13 on page 32](#))

Loopbacks can be initiated by:

- Selecting the loopback type using the MODE and SEL buttons on the H2TU-C front panel
- Selecting the NREM-CLOC dual loopback using the LBK button on the H2TU-R front panel
- Selecting the loopback type from the Monitor screen when connected to the H2TU-C or H2TU-R craft port
- Entering the loopback code into the test set connected to the craft port of the H2TU-C or H2TU-R



**The H2TU-R-402 List 6E performs a metallic loopback self test when looping up an NREM or SMJK loopback.**

**HiGain supports multiple loopbacks, but a single loopback is the preferred method.**

## Generic Loopback Commands

The HiGain Generic Loopback (GNLB) commands allow you to use inband codes to loop up either NLOC (4-in-7) or NREM (3-in-7) towards the network. In addition, these inband codes loop up CREM (6-in-7) or CLOC (5-in-7) towards the customer. Either loopup condition can be terminated (looped down) with the 3-in-5, SMJK loopdown code. All inband codes must be present for at least 5 seconds before the HiGain system responds. TLOS is a logic loopback caused by loss of the DS1 input from the CI.

[Figure 22](#) summarizes the available loopbacks in the system, and [Table 11 on page 27](#) summarizes the HiGain generic loopback commands. See “[GNLB Test Procedures](#)” on page 28 for the test procedures that apply when using the GNLB mode.

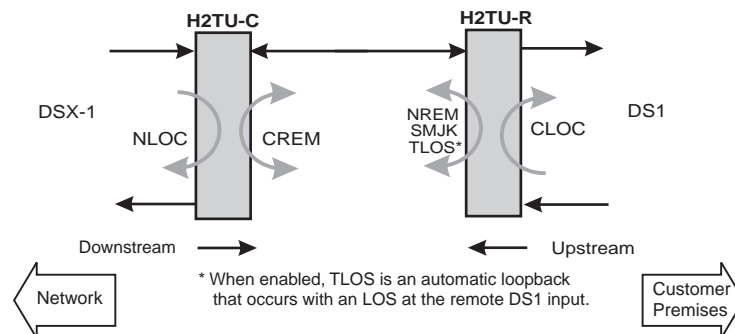

**Figure 22.** Loopback Summary

**Table 11.** Summary of HiGain Loopback Codes and Activation Methods

Loopback	Code	Description	Method of Activation		
			Test Set	Craft Port	H2TU-C MODE/SEL
NLOC	1111000 4-in-7	DSX-1 signal is looped back to the network at the H2TU-C.	X	X	X
NREM	1110000 3-in-7	DSX-1 signal is looped back to the network at the H2TU-R.	X	X	X
CLOC	1111100 5-in-7	DS1 signal from the customer is looped back to the customer at the H2TU-R.	X	X	X
CREM	1111110 6-in-7	DS1 signal from the customer is looped back to the customer at the H2TU-C.	X	X	X
SMJK LpUp (PL)	11000 2-in-5	SmartJack Loopup or NID payload (PL) code. Invokes H2TU-R loopback towards network.	X		
SMJK LpUp (ESF-DL)	1111-1111- 0100-1000	SmartJack Loopup or NID (ESF-DL) code. Invokes H2TU-R loopback towards network.	X		
SMJK LpDn (PL)	11100 3-in-5	SmartJack Loopdown or NID payload (PL) code. Removes SMJK, NLOC, NREM, CLOC, and CREM.	X		
SMJK LpDn (ESF-DL)	1111-1111- 0010-0100	SmartJack Loopdown or NID (ESF-DL) code. Removes SMJK, NLOC, NREM, CLOC, and CREM.	X		

(a) The RULB dual loopback (same as NREM-CLOC) can be activated by pressing the LBK button on the H2TU-R front panel.



HiGain systems feature the SmartJack (SMJK) option which can emulate a Network Interface Device (NID) for the purpose of loopback testing of the HiGain circuit. SMJK and NREM loopbacks perform the same functions, but their initiation differs. SMJK indicates that the loopback was initiated by the 2-in-5 inband command. NREM, on the other hand, is initiated by the 3-in-7 inband command, by the H2TU-R front panel LBK button, by a command issued from the maintenance terminal, or by the H2TU-C front panel MODE and SEL buttons.

Use the inband commands to enable or disable the SMJK loopback options. The HiGain system setting is normally enabled to recognize all inband SMJK loopback commands.

## Special Loopback Commands

In addition to the GNLB loopback command mode, a HiGain system can be configured for one of three special loopback command modes. These command modes, A2LB, A3LB, and A4LB, are selected from the ADC Options maintenance terminal screen or by using the MODE and SEL buttons on the H2TU-C front panel. Once a loopback mode is activated, other loopback commands can be sent by a test set connected to the craft port on the H2TU-C or H2TU-R front panel.

A2LB through A4LB are special, addressable, repeater loopback modes that are supported by the H2TU-R-402 (see [Table 12 on page 30](#) and [Table 13 on page 32](#) for a list of Addressable Repeater Loopback Commands). These loopback modes provide the HiGain system with sophisticated maintenance and troubleshooting tools. A2LB is patterned after the Teltrend addressable T1 repeater loopbacks. A3LB and A4LB are patterned after the Wescom addressable T1 repeater loopbacks.

These addressable repeater loopback modes have been enhanced to handle the specific requirements of the following HiGain customers:

- A2LB (Teltrend) = Southwestern Bell
- A3LB (Wescom) = New England Telephone, Bell Atlantic
- A4LB (Wescom Mod 1) = New York Telephone

A2LB can be configured to do one of the following:

- Block the arming code (after 2 seconds) from exiting the H2TU-C into the network, and replace it with the AIS code.
- Unblock the AIS code by executing the Far End Activate code.

A3LB and A4LB are now identical. Previously, they incorporated different SMJK loopback commands, which are now under control of the LPBK setting.

## LOOPBACK TEST PROCEDURES

The following sections provide step-by-step test procedures for verifying the integrity of the HDSL2 channels at every module location as well as the DS1 channels to the customer and the local DSX-1 interface.

### GNLB Test Procedures

[Figure 23 on page 29](#) is a graphical representation of the various loopback configurations with the associated GNLB commands shown. Refer to [Table 11 on page 27](#) for a description of these commands.

To perform the GNLB loopback test procedure:

- 1 Have the CO tester send the NREM (3-in-7) inband loopup code for 5 seconds. The LBK LED on the front panel should be a steady yellow, and the loopback mode should be identified on the Monitor screen.
- 2 Have the CO tester transmit a DS1 test signal towards the H2TU-R and verify that the returned (looped) signal to the test set is error-free.
- 3 If step 2 fails, have the CO tester transmit the 3-in-5 inband loopdown code.
- 4 Have the CO tester send the NLOC (4-in-7) inband loopup for 5 seconds. You should be able to observe the NLOC message on the Monitor screen.
- 5 Repeat Step 2. If the test passes, the problem is in the downstream direction. If it fails, the problem is in the upstream direction.

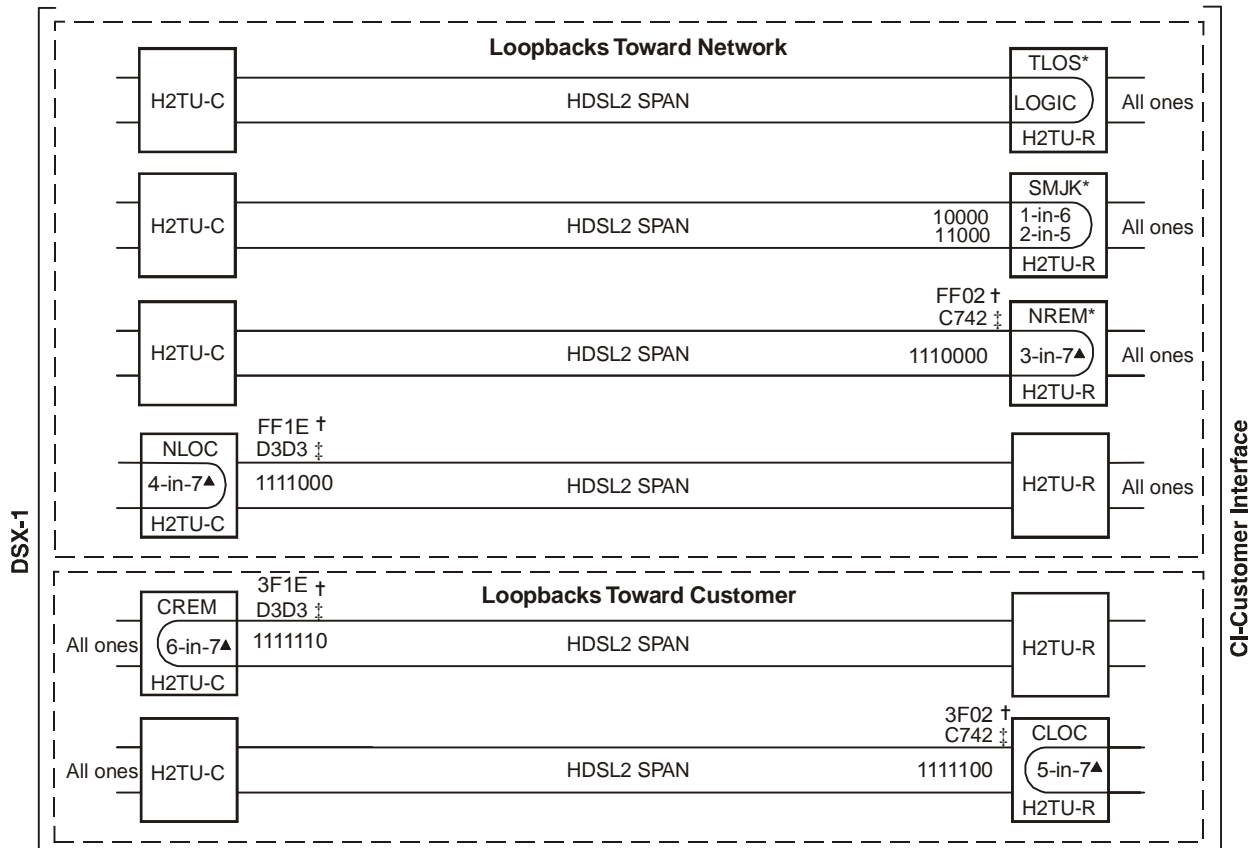

Figure 23. Loopback Modes

## A2LB Test Procedures

Using the codes listed in [Table 12](#), a network tester can activate NLOC or NREM loopbacks (or SMJK, if enabled). A tester at the customer premises can activate CLOC or CREM loopbacks.

**Table 12.** *Addressable Repeater Loopback Commands (A2LB)*

Name	Description	Binary Code <sup>(a)</sup> (Hexadecimal Equivalent)
ARMING or NI LPBK (inband)	Arming code	11000-11000 ...
ARMING or NI LPBK (ESF Datalink)	Arming code	1111-1111-0100-1000 (FF48)
IR LPDN or DISARM (inband)	Disarming code	11100-11100 ...
IR LPDN or DISARM (ESF Datalink)	Disarming code	1111-1111-0010-0100 (FF24)
IOR LPBK (NLOC and CREM) 230-232 bit errors 229-231 bit errors <sup>(b)</sup>	H2TU-C loopup	1101-0011-1101-0011 (D3D3)
ILR-2 LPBK (NREM and CLOC 20 bit errors)	H2TU-R loopup	1100-0111-0100-0010 (C742)
IR LPDN	Loopdown (H2TU-C, H2RU, or H2TU-R)	1001-0011-1001-0011 (9393)
IR QUERY LPBK	Query loopback	1101-0101-1101-0101 (D5D5)
IR ALTERNATE QUERY LPBK	Alternate query loopback	1101-0101-1110-1010 (D5EA)
TIME-OUT OVERRIDE	Loopback time-out override	1101-0101-1101-0110 (D5D6)
FAR END NI ACTIVATE	Unblock AIS	1100-0101-0101-0100 (C554)
IOR POWER DOWN (H2TU-C) <sup>(c)</sup>	Removes HDSL2 line power	0110-0111-0110-0111 (6767)

(a) The leftmost bit arrives first in all sequences. The detection algorithm functions reliably with a random  $10^{-3}$  BER on the facility. The entire arming and loopback sequence can also be initiated at the remote H2TU-R location.

(b) The H2TU-R identifies CREM (and the H2TU-C identifies NLOC) with 231 bit errors, including the frame bits. When framed data is being sent in the Auto framing mode, the number of the 231 bit errors detected by the test set varies from 229 to 231, depending on whether or not the test set counts frame errors as bit errors and on the number of frame bits contained in the block of 231 error bits. The H2TU-R and H2TU-C generate this bit pattern in a series of discontinuous bursts containing 20-bit errors each, including frame bits. Those test sets that do not count frame error bits as data bit errors will indicate fewer bits than the H2TU-R and H2TU-C transmit for a CI and NI loopback.

(c) The IOR Power Down code must remain present for the duration of the powerdown mode. When this code is removed, the HiGain system returns to its normal unlooped and unarmed state.

To perform the A2LB test procedures:

- 1 Send the inband Arming and NI LPBK code 11000 to the H2TU-R for at least 5 seconds.
- 2 Monitor the output of the H2TU-R for the return of the pattern. Return of the pattern indicates one of the following:
  - The H2TU-R has looped up (if the SMJK Loopback option is enabled).
  - An external NID has looped up (if the SMJK Loopback option is disabled), and the H2TU-C and H2TU-R have been armed.

- 3 Verify, if possible, that the H2TU-R LBK LED is either flashing yellow at 4-second intervals (indicating that the system is armed), or is a steady yellow (indicating that it is both armed and in SMJK loopback). The H2TU-C Status LED also flashes yellow when the system is armed.



**If the Arming code is not returned after 5 seconds, the system may be armed, but there is no active loopback.**

- 4 Once armed, the H2TU-R can be looped back by sending Intelligent Office Repeater (IOR) LPBK activation code 1101-0011-1101-0011 (D3D3) for at least 5 seconds. You should observe the following activation response pattern:
- a 2 seconds of AIS (all ones pattern)
  - b 2 seconds of returning data pattern
  - c Logic errors, (including the frame bit) occurring in the returned pattern comprising:
    - 231 logic errors, if IOR LPBK (H2CU-C) was sent
    - 20 errors, if ILR-2 (H2TU-R) was sent
  - d Normal looped data

This error pattern repeats every 20 seconds as long as the IOR loopback pattern is being sent. This also applies to ILR, Time-Out Override, and Query commands.

The H2TU-C is now in logic loopback if the IOR NLOC loopback command was sent. The Time-Out Override command or a Loopdown command can override the selection made for the loopback Time-Out. If the Time-Out Override code 1101-0101-1101-0110 (D5D6) is received after activating a loopback, then the automatic timed expiration of the loopback is inhibited. If this Time-Out Override is sent, then the only way to loop the H2TU-R down is to do one of the following:

- Issue the IR loopdown (LPDN) code 1001-0011-1001-0011 (9393).
- Issue the NI LPDN and Disarm inband code 11100 or the ESF-DL code (FF24).



**The Time-Out Override function is only valid for the current active loopback. The automatic time-out timer is restored during subsequent loopback sessions.**

- 5 Once the test is complete, do one of the following:
- If the system is to loop down but remain Armed, send the IR LPDN code.
  - If all the equipment is to be looped down, disarmed, and returned to normal operation, send the disarm inband code 11100 or the ESF-DL code (FF24).



**The Armed mode has an automatic time-out of 120 minutes, but this timer is reset to 120 for any of the following events:**

- **Loopback terminates (manually or time-out)**
- **Query**
- **Alternate query**
- **Far End activate**
- **Another ARM command**

**This timer is inhibited while any of the valid command codes are being sent. Once the codes are removed, the timer restarts at 120.**

## A3LB and A4LB Test Procedures

The H2TU-C can be looped back by sending the Addressable Office Repeater (AOR) LPBK activation code 1111-1111-0001-1110 (FF1E) for at least 5 seconds. This causes the H2TU-R to enter the NLOC state. The H2TU-C Loopback Time-Out (LBTO) setting determines the duration of this loopback unless it is overridden by the reception of a second identical 16-bit loopup command before the timer expires. When this time-out override state exists, the only way to loop the H2TU-R down is to issue one of the three loopdown commands listed in Table 13. The automatic time-out mode is restored during subsequent loopback sessions.

Table 13 summarizes the codes required to execute Addressable 3 (A3LB) and Addressable 4 (A4LB) repeater loopback commands. All code sequences must be present for at least 5 seconds.

**Table 13.** Addressable Repeater Loopback Commands (A3LB and A4LB)

Name	Description	Binary Code <sup>(a)</sup> (Hexadecimal Equivalent)
NLOC	H2TU-R loopup from NI	1111-1111-0001-1110 (FF1E)
CREM	H2TU-R loopup from CI	0011-1111-0001-1110 (3F1E)
NREM	H2TU-R loopup from NI	1111-1111-0000-0010 (FF02)
CLOC	H2TU-R loopup from CI	0011-1111-0000-0010 (3F02)

(a) The leftmost bit arrives first in all sequences. The detection algorithm functions reliably with a random  $10^{-3}$  Bit Error Ratio (BER) on the facility.

## SmartJack Test Procedure

The HiGain H2TU-R supports the standard SmartJack loopback which can emulate a Network Interface Device (NID) for the purpose of loopback testing of the HiGain HDSL2 circuit. SMJK and NREM loopbacks perform the same functions, but their initiation differs. SMJK indicates that the loopback was initiated by any of the three SmartJack loopup commands listed in Table 14. NREM, on the other hand, is initiated by the 3-in-7 inband command or by a command issued from the maintenance terminal.

The SmartJack loopback option, LPBK, enables or disables the ability of the H2TU-R to emulate the family of SmartJack loopback commands listed in Table 14.

**Table 14.** SmartJack Loopup and Loopdown Commands

In-Band 2-in-5 Loopup Code	In-Band 3-in-5 Loopdown Code <sup>(a)</sup>	Out-of-Band ESF FDL Loopup Codes	Out-of-Band ESF FDL Loopdown Codes <sup>(a)</sup>	In-Band 1-in-6 Loopup Code	In-Band 1-in-3 Loopdown Code <sup>(a)</sup>
11000	11100	1111-1111-0100- 1000	1111-1111-0100-1000	100000	100

(a) These universal loopdown codes can release any and all existing loopup states regardless of loopback direction or method of initiation. The codes are permanently enabled and independent of all loopback option settings, including the LPBK option.



**SMJK loopbacks can only be activated by inband commands.**



# APPENDIX A - SPECIFICATIONS

## Power

HDSL2 Span Voltage	-180 Vdc $\pm$ 5 Vdc
Line or Local Power Consumption	5W
Electrical Protection	Secondary surge and power cross-protection on all DS1 and HDSL2 ports.

## Environmental

Operating Temperature	-40°F to +149°F (-40°C to +65°C)
Operating Humidity	5% to 95% (non-condensing)

## Physical

Height	5.56 in. (14.12 cm)
Width	0.69 in. (1.75 cm)
Depth	5.87 in. (14.91 cm)
Weight	6.4 oz. (0.18 kg)
Mounting	400 or 200 mechanics

## HDSL2

Line Rate	1.552 Mbps Overlapped Pulse Amplitude Modulation Transmission with Interlocking Spectra (OPTIS)
Transmission	Full duplex
Media	One non-loaded, copper, two-wire cable pair
Output	+16.5 dBm $\pm$ 0.5 dB at 135 $\Omega$ (0-350 kHz) at remote side; +16.8 dBm $\pm$ 0.5 dB at 135 $\Omega$ (0-450 kHz) at CO side
Line Impedance	135 $\Omega$
Maximum Loop Attenuation	35 dB at 196 kHz, 135 $\Omega$
Start-up Time	30 sec. (typical), 1 min. (maximum) per span

## DS1

Line Impedance	100 $\Omega$
Line Rate	1.544 Mbps $\pm$ 200 bps
Line Format	Alternate Mark Inversion (AMI) or Bipolar with 8-Zero Substitution (B8ZS)
Frame Format	Extended SuperFrame (ESF), SuperFrame (SF), or Unframed (UNFR)
Pulse Output	0 dB, -7.5 dB, -15 dB
Input Level	0 to -33 dB

## System

One-way DS1 Delay	<400 $\mu$ s
Wander (Looped)	Meets MTIE T1.101 requirements
Wideband Jitter (Looped)	0.2 UI maximum
Narrowband Jitter (Looped)	0.1 UI maximum

# LOOP ATTENUATION

Each loop has no more than 35 dB of loss at 196 kHz, with driving and terminating impedances of 135Ω (see Table 15).

**Table 15. HDSL2 Cable Attenuation Chart**

Cable Gauge	Loss at 196 kHz (dB/kft)	Ω per kft
26/0.4 mm	3.88	83
24/0.51 mm	2.84	52
22/0.61 mm	2.18	32
19/0.91 mm	1.54	16

# H2TU-R-402 LIST 6E CARD-EDGE CONNECTOR

Figure 24 shows the card-edge connectors on the H2TU-R-402 List 6E. Active pins are highlighted in black.

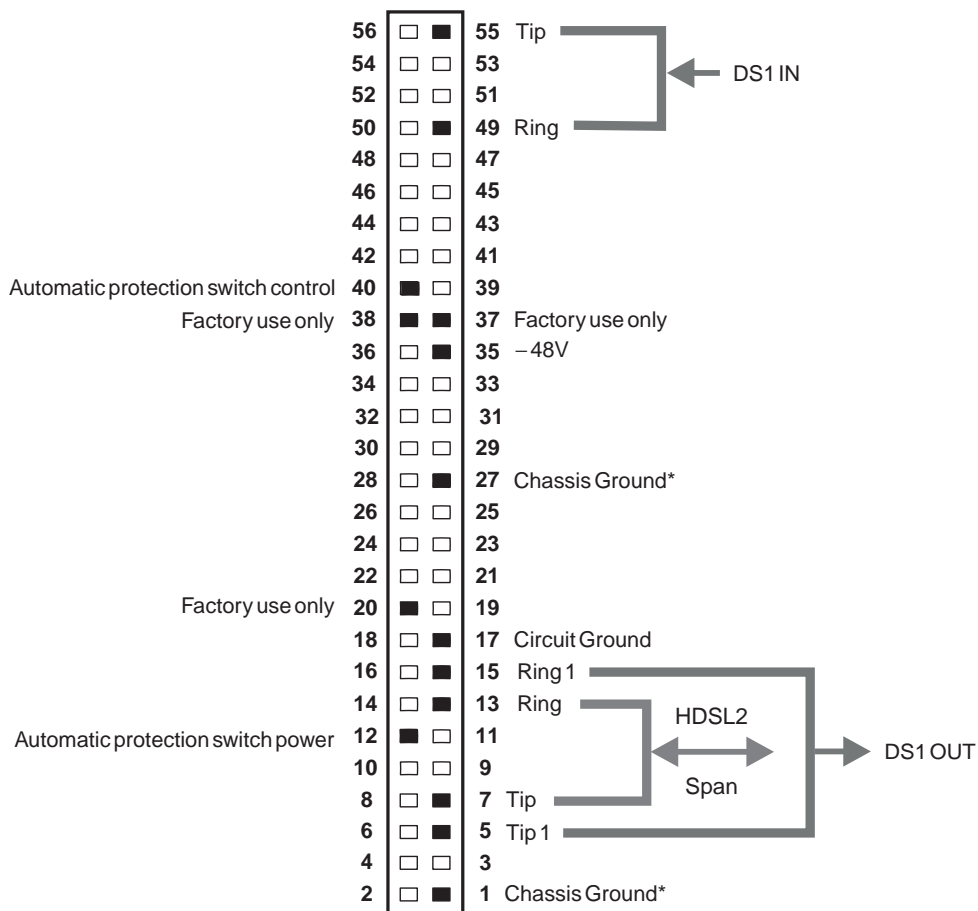

Active pins are highlighted in black.

\* Chassis Ground may be tied to Earth Ground according to local practice.

**Figure 24. H2TU-R-402 List 6E Card-Edge Connector**

## CRAFT PORT

Figure 25 shows the pinout for the craft port connector and its connection to a DB-9 or DB-25 connector on a maintenance terminal.

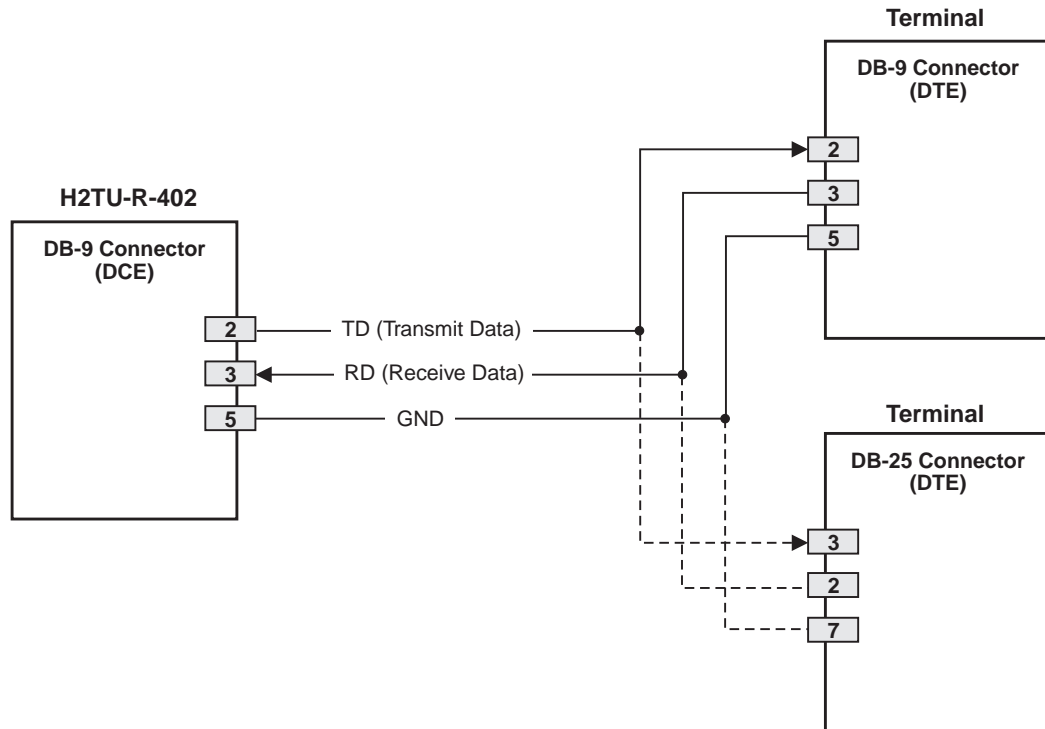

Figure 25. RS-232 Craft Port Pinouts

### Local and Line Power

The H2TU-R-402 can be line-powered from the H2TU-C over the HDSL2 span, or it can be powered by 48V local power supply applied to pins 35 and 17 as shown in Figure 18 on page 21.

The H2TU-R-402 supports both line powering through the upstream device and local powering using -42.5V to -56.5V provisioned via hardware jumpers. A hardware jumper provided on the board enables a sealing current sink path at the remote unit.

When used with the H2TU-C- 402 List 4E, H2TU-C- 402 List 5E or H2TU-C- 319 List 1E, the H2TU-R-402 provides a resistive termination at its HDSL2 port.

# APPENDIX B - FUNCTIONAL OPERATION

ADC HDSL2 technology provides full-duplex services at standard DS1 rates over copper wires between an H2TU-C and an H2TU-R, which comprise one HiGain system. HiGain systems use ADC Overlapped Pulse Amplitude Modulation (PAM) Transmission with Interlocking Spectra (OPTIS) transceiver systems to establish full-duplex, 1.552 kbps data channels between the remotely located H2TU-R-402 List 6E and an H2TU-C.

A block diagram of the H2TU-R-402 List 6E is shown in Figure 26.

The H2TU-R-402 List 6E power supply converts the 185 Vdc power that is received over the HDSL2 span to voltage and currents required by the remote unit circuitry. In addition, it can be powered by a 48 V local power supply.

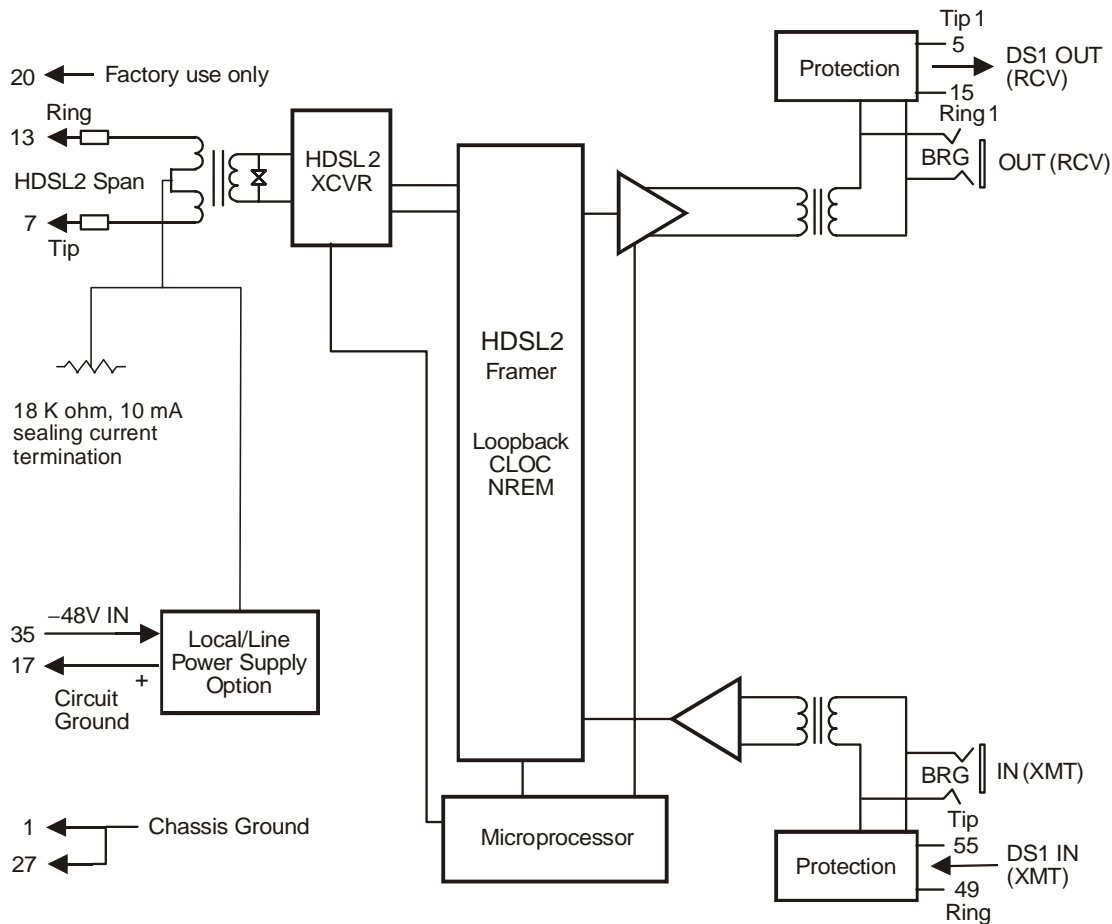

Figure 26. H2TU-R-402 List 6E Block Diagram

## TIMING

The low-loop wander (0.3 UI max) of an H2TU-R, when used with compatible line units, allows the circuit to be used in all critical timing applications, including those that are used to transport Stratum 1 timing.

# APPENDIX C - COMPATIBILITY

The HiGain system uses HDSL2 transmission technology as recommended by Bellcore TA-TSY-001210. HiGain complies with GR-63-CORE, TR-TSY-000499, and GR-1089-CORE.

The H2TU-R-402 List 6E is compatible with the following shelves (for indoor use):

- HRE-206 (six-slot)
- HRE-204 (four-slot)
- HRE-420 (single-slot)
- HRE-425 (12-slot wall or rack mount)
- 200 Mechanics type shelves
- 400 Mechanics type shelves

For outdoor applications, the H2TU-R-402 List 6E is compatible with the following enclosures:

- HRE-450 List xB (single-slot)
- HRE-454 (four-slot)

# APPENDIX D - PRODUCT SUPPORT

ADC Customer Service Group provides expert pre-sales and post-sales support and training for all its products. Technical support is available 24 hours a day, 7 days a week by contacting the ADC Technical Assistance Center (TAC).

<b>Sales Assistance</b> 800.366.3891 extension 73000 (USA and Canada) 952.917.3000 Fax: 952.917.3237	<ul style="list-style-type: none"> <li>• Quotation Proposals</li> <li>• Ordering and Delivery</li> <li>• General Product Information</li> </ul>
<b>Systems Integration</b> 800.366.3891, extension 73000 (USA and Canada) 952.917.3000	<ul style="list-style-type: none"> <li>• Complete Solutions (from concept to installation)</li> <li>• Network Design and Integration Testing</li> <li>• System Turn-Up and Testing</li> <li>• Network Monitoring (upstream or downstream)</li> <li>• Power Monitoring and Remote Surveillance</li> <li>• Service/Maintenance Agreements</li> <li>• Systems Operation</li> </ul>
<b>BIA Technical Assistance Center</b> 800.638.0031 714.730.3222 Fax: 714.730.2400 Email: <a href="mailto:wsd_support@adc.com">wsd_support@adc.com</a>	<ul style="list-style-type: none"> <li>• Technical Information</li> <li>• System/Network Configuration</li> <li>• Product Specification and Application</li> <li>• Training (product-specific)</li> <li>• Installation and Operation Assistance</li> <li>• Troubleshooting and Repair/Field Assistance</li> </ul>
<b>Online Technical Support</b>	<ul style="list-style-type: none"> <li>• <a href="http://www.adc.com/Knowledge_Base/index.jsp">www.adc.com/Knowledge_Base/index.jsp</a></li> </ul>
<b>Online Technical Publications</b>	<ul style="list-style-type: none"> <li>• <a href="http://www.adc.com/library1/">www.adc.com/library1/</a></li> </ul>
<b>Product Return Department</b> 800.366.3891 ext. 73748 or 952.917.3748 Fax: 952.917.3237 Email: <a href="mailto:repair&amp;return@adc.com">repair&amp;return@adc.com</a>	<ul style="list-style-type: none"> <li>• ADC Return Material Authorization (RMA) number and instructions must be obtained before returning products.</li> </ul>

*All 800 lines are toll-free in the USA and Canada.*

# APPENDIX E - LIST OF ABBREVIATIONS

## B

**BPVT:** Bipolar Violation Transparency  
**BRG:** Bridge

## C

**CLEI:** Common Language Equipment Identifier  
**CO:** Central Office  
**CREM:** Customer Remote Loopback  
**CSA:** Carrier Service Area  
**CV:** Code Violation

## D

**DDS:** Digital Data Service

## E

**ECI:** Equipment Catalog Item  
**ES:** Errored Seconds  
**ESD:** Electrostatic Discharge  
**EXZ:** The occurrence of 8 consecutive zeroes for B8ZS or 16 for AMI.

## G

**GNLB:** Generic Loopback

## H

**HCDS:** High Capacity Digital Service  
**HDSL2:** High-bit-rate Digital Subscriber Line 2  
**HG:** HiGain

## I

**IN:** Transmit  
**IR:** Intelligent Repeater

## L

**LBTO:** Loopback Time-Out  
**LOSW:** Loss of Sync Word  
**LPF:** Line Power Feed

## M

**M:** HDSL2 Margin  
**MSEC:** Monitored Seconds

## N

**NE:** Near End  
**NID:** Network Interface Device

## O

**OPTIS:** Overlapped Pulse Amplitude Modulation Transmission with Interlocking Spectra  
**OUT:** Receive

## P

**PBOC:** Power Back Off Customer  
**PBON:** Power Back Off Network

## S

**SES:** Severely Errored Seconds





---

# CERTIFICATION AND WARRANTY

## FCC CLASS A COMPLIANCE

This equipment has been tested and found to comply with the limits for a Class A digital device, pursuant to Part 15 of the FCC Rules. These limits are designed to provide reasonable protection against harmful interference when the equipment is operated in a commercial environment. This equipment generates, uses, and can radiate radio frequency energy and, if not installed and used in accordance with the instruction manual, may cause harmful interference to radio communications. Operation of this equipment in a residential area is likely to cause harmful interference in which case the user will be required to correct the interference at his own expense.

## LIMITED WARRANTY

ADC DSL Systems, Incorporated (“ADC”) warrants that, for a period of sixty (60) months from the date of shipment, the hardware portion of its products will be free of material defects and faulty workmanship under normal use. ADC's obligation, under this warranty, is limited to replacing or repairing, at ADC's option, any such hardware product which is returned during the 60-month warranty period per ADC's instructions and which product is confirmed by ADC not to comply with the foregoing warranty.

ADC warrants that, for a period of 90 days from the date of purchase, the software furnished with its products will operate substantially in accordance with the ADC published specifications and documentation for such software. ADC's entire liability for software that does not comply with the foregoing warranty and is reported to ADC during the 90-day warranty period is, at ADC's option, either (a) return of the price paid or (b) repair or replace of the software. ADC also warrants that, for a period of thirty (30) days from the date of purchase, the media on which software is stored will be free from material defects under normal use. ADC will replace defective media at no charge if it is returned to ADC during the 30-day warranty period along with proof of the date of shipment.

The transportation charges for shipment of returned products to ADC will be prepaid by the Buyer. ADC will pay transportation charges for shipment of replacement products to Buyer, unless no trouble is found (NTF), in which case the Buyer will pay transportation charges.

ADC may use reconditioned parts for such repair or replacement. This warranty *does not* apply to any product which has been repaired, worked upon, or altered by persons not authorized by ADC or in ADC's sole judgment has been subjected to misuse, accident, fire or other casualty, or operation beyond its design range.

Repaired products have a 90-day warranty, or until the end of the original warranty period—whichever period is greater.

ADC DISCLAIMS ALL OTHER WARRANTIES, EITHER EXPRESS OR IMPLIED, INCLUDING BUT NOT LIMITED TO IMPLIED WARRANTIES OF MERCHANTABILITY AND FITNESS FOR A PARTICULAR PURPOSE, WITH RESPECT TO ITS PRODUCTS AND ANY ACCOMPANYING WRITTEN MATERIALS. FURTHER, ADC DOES NOT WARRANT THAT SOFTWARE WILL BE FREE FROM BUGS OR THAT ITS USE WILL BE UNINTERRUPTED OR REGARDING THE USE, OR THE RESULTS OF THE USE, OF THE SOFTWARE IN TERMS OF CORRECTNESS, ACCURACY, RELIABILITY OR OTHERWISE.

## MODIFICATIONS

Any changes or modifications made to this device that are not expressly approved by ADC DSL Systems, Inc. voids the user's warranty.

All wiring external to the products should follow the provisions of the current edition of the National Electrical Code.

## STANDARDS COMPLIANCE

The H2TU-R-402 List 6E has been tested and verified to comply with the applicable sections of the following standards:

- GR 63-CORE - Network Equipment-Building System (NEBS) Requirements
- GR 1089-CORE - Electromagnetic Compatibility and Electrical Safety
- Binational standard, UL-1950/CSA-C22.2 No. 950-95: Safety of Information Technology Equipment

For technical assistance, refer to “Appendix D - Product Support” on page 38.

---

**ADC DSL Systems, Inc.**

14402 Franklin Avenue  
Tustin, CA 92780-7013

Tel: 714.832.9922

Fax: 714.832.9924

**Technical Assistance**

800.638.0031

714.730.3222



DOCUMENT  
LTPH-UM-1106-02, ISSUE 2



1227899

