

TECHNICAL PRACTICE

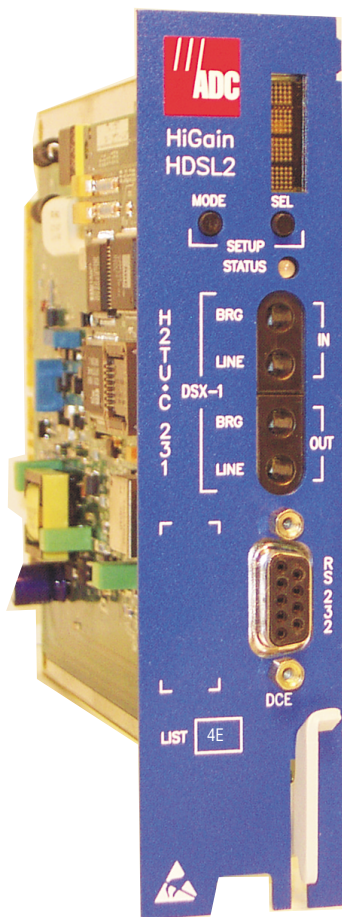

H2TU-C-231 List 4E Line Unit
Product Catalog: H2TU-C-231-L4E
CLEI: VACJDLHE

Revision History of This Practice

To order copies of this document, use document catalog number LTPH-TP-1034-01.

Issue	Release Date	Revisions Made
1	September 28, 2001	Initial release.

Copyright

September 28, 2001

© 2001 ADC DSL Systems, Inc. All rights reserved.

Trademark Information

ADC is a registered trademark of ADC Telecommunications, Inc.

HiGain is a registered trademark of ADC DSL Systems, Inc. No right, license, or interest to such trademarks is granted hereunder, and you agree that no such right, license, or interest shall be asserted by you with respect to such trademark.

Other product names mentioned in this practice are used for identification purposes only and may be trademarks or registered trademarks of their respective companies.

Disclaimer of Liability

Information contained in this document is company private to ADC DSL Systems, Inc., and shall not be modified, used, copied, reproduced or disclosed in whole or in part without the written consent of ADC.

Contents herein are current as of the date of publication. ADC reserves the right to change the contents without prior notice. In no event shall ADC be liable for any damages resulting from loss of data, loss of use, or loss of profits, and ADC further disclaims any and all liability for indirect, incidental, special, consequential or other similar damages. This disclaimer of liability applies to all products, publications and services during and after the warranty period.

USING THIS TECHNICAL PRACTICE

The following conventions are used in this manual:

- Monospace type indicates screen text.
- Keys you press are indicated by small icons such as **Y** or **ENTER**. Key combinations to be pressed simultaneously are indicated with a plus sign as follows: **CTRL** + **ESC**.
- Items you select are in **bold**.
- Three types of messages, identified by icons, appear in text.



Notes contain information about special circumstances.



Cautions indicate the possibility of personal injury or equipment damage.



The Electrostatic Discharge (ESD) symbol indicates that a device or assembly is susceptible to damage from electrostatic discharge.

For a list of abbreviations used in this document, refer to [“Appendix E - Abbreviations”](#) on page 64.

INSPECTING SHIPMENT

Upon receipt of the equipment:

- Unpack each container and inspect the contents for signs of damage. If the equipment has been damaged in transit, immediately report the extent of damage to the transportation company and to ADC. Order replacement equipment, if necessary.
- Check the packing list to ensure complete and accurate shipment of each listed item. If the shipment is short or irregular, contact ADC as described in [“Returns”](#) on page 63. If you must store the equipment for a prolonged period, store the equipment in its original container.

TABLE OF CONTENTS

Overview	1
Features	1
Compatibility	2
Applications	2
Front Panel	3
Installation	7
Verification	8
Verification without an H2TU-R Remote Unit	8
Verification with an H2TU-R Remote Unit	8
Provisioning	9
Using the MODE and SEL Pushbuttons	9
Setting Options through MODE and SEL	9
Resetting to Factory Defaults	10
Displaying System Parameter Settings	10
Disabling an Alarm	10
Loopback Modes	10
Using a Maintenance Terminal	10
Connecting to a Maintenance Terminal	10
Logon Screen	11
Provisioning Tasks	13
Setting Date and Time	13
Setting Circuit ID Numbers	14
Configuring the System	15
Clearing the History, Alarm, and Event Log Screens	26
Monitoring System Activity and Performance	28
Using the Monitor Screen to View System Activity	28
Using the Performance Screens to View Performance Data	30
Performance History at the DS1 Interface	30
Performance History at the HDSL2 Interface	34
Using the Performance Screens to View Alarm Data	36
Alarm History at the DS1 Interface	36
Alarm History at the HDSL2 Interface	39
Using the System Event Log to Track Events	40
Using the Report Menu	42

Testing	44
System Alarms.....	44
Alarm Option for Digital Loop Carrier (DLC) Feed	45
Retiring System Alarms	45
Remote LOS and AIS Response	46
OCT55 Test Pattern with AMI Code.....	46
Loopback Operation	47
Generic Loopback Commands	48
Special Loopback Commands.....	48
SmartJack Loopback Commands.....	49
Manual Loopback Session.....	49
In-Band Loopback Sessions	50
General Troubleshooting Tips	50
GNLB Test Procedures	50
A2LB Test Procedures	52
A3LB and A4LB Test Procedures	54
SmartJack Test Procedure	54
Appendix A - Specifications	55
Power Consumption	56
Maximum Power Dissipation	56
Maximum Current Drain	56
Loop Attenuation.....	57
H2TU-C-231 List 4E Card-Edge Connector.....	58
Network Management Control Bus	58
Fuse Alarm.....	59
System Alarm Output Pins.....	59
Craft Port	59
Appendix B - Functional Operation	60
Timing	61
Ground Fault Detect	61
Appendix C - Compatibility	62
Appendix D - Product Support	63
Technical Support.....	63
Returns.....	63
Appendix E - Abbreviations	64
Certification and Warranty	Inside Back Cover

LIST OF FIGURES

1. H2TU-C-231 List 4E Front Panel	3
2. Installing the H2TU-C-231 List 4E into a Shelf	7
3. Logon Screen.....	12
4. Config Menu - Date and Time.....	13
5. Inventory Screen.....	14
6. Config Menu.....	15
7. Config Menu - Standard Options (defaults shown).....	16
8. Config Menu - ADC Options (defaults shown)	16
9. Config Menu - Set Factory Defaults	26
10. Config Menu - Master Clear.....	27
11. Monitor Screen - Active Loopback with Alarms	28
12. H2TU-R DS1 31-Day Performance History	30
13. H2TU-C DS1 48-Day Performance History	31
14. H2TU-R DS1 25-Hour Performance History.....	31
15. H2TU-R DS1 Current Statistics	32
16. H2TU-C DS1 Current Statistics	32
17. H2TU-C HDSL2 31-Day Performance History	34
18. H2TU-C HDSL2 48-Hour Performance History	34
19. H2TU-C HDSL2 25-Hour Performance History	35
20. H2TU-C HDSL2 Current Statistics.....	35
21. H2TU-C DS1 Alarm History Screen.....	37
22. H2TU-R DS1 Alarm History Screen.....	37
23. H2TU-C HDSL2 Alarm History Screen	39
24. System Event Log.....	40
25. Report Menu - Full Report	42
26. H2TU-R LOS and AIS Response Priorities	46
27. Loopback Summary.....	47
28. Loopback Modes	51
29. H2TU-C-231 List 4E Card-Edge Connector	58
30. RS-232 Craft Port Pinouts	59
31. H2TU-C-231 List 4E Block Diagram	60

LIST OF TABLES

- 1. Front-Panel Description 4
- 2. Front-Panel Display Messages..... 5
- 3. Navigational Keys for the Maintenance Terminal Screens 11
- 4. Logon Screen Menus 12
- 5. H2TU-C-231 List 4E Standard Config Menu Options 17
- 6. H2TU-C-231 List 4E ADC Config Menu Options..... 18
- 7. DS1 and DSX-1 24-Hour PM Threshold..... 21
- 8. Response to H2TU-R DS1 Frame Conversion Options 23
- 9. Extended SuperFrame Format 23
- 10. SuperFrame Format 24
- 11. DDS NI and DS0 DP Latching Loopback Sequence..... 24
- 12. HiGain HDSL2 Loopback vs. Latching Sequence 25
- 13. Response of H2TU-C and H2TU-R to LOS and AIS..... 25
- 14. Monitor Screen Descriptions 29
- 15. Error Acronyms Used on the DS1 Performance History Screens 33
- 16. Error Acronyms Used on the HDSL2 Performance History Screens 36
- 17. DS1 Alarm Descriptions 38
- 18. HDSL2 Alarm Descriptions..... 39
- 19. Event Log Entry Messages List..... 41
- 20. Report Types..... 43
- 21. Front-Panel System Alarms Summary 44
- 22. Summary of HiGain HDSL2 Generic Loopback Codes and Activation Methods 48
- 23. Addressable Repeater Loopback Commands (A2LB)..... 52
- 24. Addressable Repeater Loopback Commands (A3LB and A4LB)..... 54
- 25. SmartJack Loopup and Loopedown Commands 54
- 26. H2TU-C Power Parameters 56
- 27. HDSL2 Cable Attenuation Chart..... 57

OVERVIEW

The H2TU-C-231 List 4E line unit is the Central Office (CO) side of a T1 transmission system. The HiGain® HDSL2 product family is fully compliant with the HDSL2 standard ANSI T1.418-2000. Providing full-rate T1 access using a single copper pair, HDSL2 is a cost-effective solution that offers an open architecture. The open architecture inherent in HDSL2 guarantees interoperability allowing simple and economic accommodation of network growth.

HiGain HDSL2 products provide 1.544 Mbps transmission on one unconditioned copper pair over the full Carrier Service Area (CSA) range. The CSA includes loops up to 12,000 feet of 24 AWG wire or 9,000 feet of 26 AWG wire, including bridged taps.

FEATURES

- HDSL2 transmission features
 - Lightning and power cross-protection on HDSL2 interfaces
 - Full-duplex HDSL2 transmission on one pair at 1.552 Mbps
 - Ultra-low wander (Stratum 1 compliant)
 - Grounded loop detection on High-bit-rate Digital Subscriber Line 2 (HDSL2)
 - Sources sealing current when connected to an H2TU-R-402 List 5E or higher
- Front-panel provisioning features
 - Four-character status display
 - DS1 splitting and bridging access
 - Status Light Emitting Diodes (LEDs)
 - RS-232 craft port for connection to a maintenance terminal
 - MODE and SEL pushbuttons
- Maintenance screens for inventory, provisioning, and troubleshooting
 - DS1 and HDSL2 performance monitoring
 - Non-volatile alarm histories
 - Performance Report Messaging (PRM) support for Supplemental PRM (SPRM) and Network PRM (NPRM) at the H2TU-R
 - Payload (PL) and HiGain (HG) loopback source identification
 - Margin Alarm (MAL) threshold
 - Report menu option for downloading status and performance monitoring data to a file
- Configuration options
 - Selectable DS1 pre-equalizer
 - Bipolar Violation Transparency (BPVT)
 - Bit Error Rate (BER) alarm
 - Loss of Signal/Alarm Indication Signal (LOS/AIS) payload alarm
 - Remote provisioning
 - Selectable loopback activation codes

- Supports the in-band 100 loopdown command for all loopback modes
- Supports the in-band 100000 loopup command when SmartJack loopback (LPBK) option is enabled
- Power Back Off Customer (PBOC) and Power Back Off Network (PBON) options for configuring power output levels
- Compatible with Small Cross-Section Shelf (SXSS) and equipment
- Digital Data Service (DDS) latching loopback
- Network Management and Administration (NMA) interface
- Supports interoperability



DS1 is used throughout this document to refer to either the remote unit's DS1 interface or the line unit's DSX-1 interface.

COMPATIBILITY

The H2TU-C-231 List 4E is designed to mount in 220 mechanics shelves. For a list of compatible shelves, see [“Appendix C - Compatibility” on page 62.](#)

APPLICATIONS

HiGain HDSL2 systems provide a cost-effective, easy-to-deploy method for delivering T1 High Capacity Digital Service (HCDS) over a single copper pair. HiGain HDSL2 systems support a multitude of network connections.

- The service is deployed over one unconditioned, non-loaded copper pair.
- Conventional, inline DS1 repeaters are no longer required.
- Cable pair conditioning, pair separation, and bridged tap removal are not required.

Each loop has no more than 35 dB of loss at 196 kHz, with driving and terminating impedances of 135Ω. In general, HiGain HDSL2 systems:

- Operate effectively in the same cable binder group with other HDSL2 lines, HDSL, DS1, ADSL, SDSL, POTS, DDS, and other transmission schemes.
- Can be used with customers requiring DS1 service on a temporary or permanent basis.
- Provide a means of quickly deploying service in advance of fiber-optic transmission systems.

FRONT PANEL

Figure 1 shows the H2TU-C-231 List 4E front panel. Table 1 on page 4 describes the front-panel components. For pinout diagrams of the H2TU-C card-edge connector and craft port, refer to “Appendix A - Specifications” on page 55.

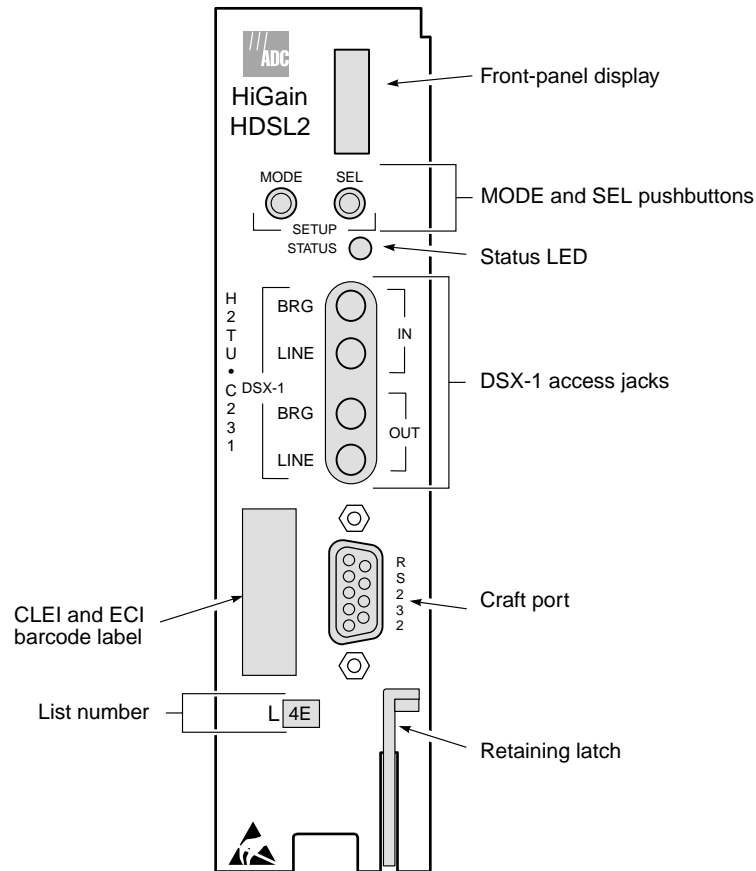

Figure 1. H2TU-C-231 List 4E Front Panel

Table 1. Front-Panel Description

Front-Panel Feature	Function
Front-panel display	Displays four-character status, provisioning, and alarm system messages. The front-panel display illuminates when power is initially applied. To conserve power, the display only remains on for 5 minutes. Using the MODE or SEL pushbuttons reactivate the display and restart the 5-minute timer. Refer to Table 2 on page 5 for a listing of the four-character messages.
MODE and SEL pushbuttons	Permits the user options to be monitored and modified without the need of a maintenance terminal. Used to initiate all HiGain HDSL2 loopbacks and to display DSX-1 line parameters and line unit identity.
Status LED	The status LED can report the following conditions:
Off	Line power is off.
Green	Normal operation.
Red	Fuse alarm.
Flashing red	HDSL2 acquisition or system alarm.
Yellow	An H2TU-C Customer Remote Loopback (CREM) or a Network Local Loopback (NLOC) is in effect.
Flashing yellow	H2TU-C is in an Armed (ARM) state.
DSX-1 access jacks	
BRG	Provides non-intrusive bridging jack access to (IN) and from (OUT) the HDSL2 span at the DSX-1 interface. Allows the two DS1 payloads to be monitored.
LINE	Provides splitting jack access to (IN) and from (OUT) the HDSL2 span at the DSX-1 interface. Breaks the IN and OUT paths to permit test signal insertion and retrieval.
Craft port (RS-232)	Provides bidirectional communication between the unit and an external terminal to allow configuration and performance monitoring through the maintenance terminal screens.
CLEI and ECI bar code label	Provides the human-readable Common Language Equipment Identifier (CLEI) code number and the Equipment Catalog Item (ECI) bar code number.
List number	Identifies the list number of the H2TU-C.
Retaining latch	Retains the card in the shelf when pulled up and extracts the card from the shelf when pulled down.

Table 2 lists the front-panel display messages. The four-character display reports the code of a pertinent alarm, loopback, or diagnostic message and, in some cases, is followed by a four-character message that modifies the first message with a value or current configuration setting.

Table 2. Front-Panel Display Messages

Message	Full Name	Description
ALARM MESSAGES		
ACO	Alarm Cutoff	A system alarm has occurred and has been retired to an ACO condition by pressing the SEL pushbutton on the H2TU-C front panel.
ALRM	Alarm Condition Exists	A system alarm condition is in effect.
DBER	DS1 Bit Error Rate	A system DS1 BER alarm is in effect and remains in effect until cleared.
HBER	HDSL2 Block Error Rate	A system HDSL2 Block Error Rate alarm is in effect.
LA	Loop Attenuation	Indicates that the attenuation on the HDSL2 loop has exceeded the maximum threshold value.
LAIS	Line Alarm Indication Signal	Indicates an AIS (unframed all ones) pattern is being received or transmitted at the H2TU-C DS1 input or output ports.
LLOS	Line (Unit) Loss of Signal	Indicates that no signal is detected at the DSX-1 input to the H2TU-C. Causes a system alarm.
LOSW	Loss of Sync Word	Indicates that the HDSL2 loop has lost synchronization.
MAL	Margin Alarm	The margin on HDSL2 loop has dropped below the threshold (0 to 15 dB) as set by the operator.
PWR FEED GND	Power Feed Ground	The HDSL2 loop is grounded.
PWR FEED OPEN	Power Feed Open	Indicates a line power open condition.
PWR FEED SHRT	Power Feed Short	Indicates a short between the Tip and Ring of the HDSL2 pair.
PRMF	Performance Report Messaging - Far End	H2TU-R PRM-FE BER threshold has been exceeded.
PRMN	Performance Report Messaging - Near End	H2TU-R PRM-NE BER threshold has been exceeded.
RAIS	Remote Alarm Indication Signal	Indicates an AIS (unframed all ones) pattern is being received or transmitted at the H2TU-R DS1 input or output ports.
RLOS	Remote (Unit) Loss of Signal	Indicates that no signal is detected at the DS1 input to the H2TU-R. Causes a system alarm.
RRAI	Remote RAI—Remote Alarm Indication at the H2TU-R (Net signal has errors.)	Indicates an RAI alarm (yellow) from the CPE with errors from the line unit or network.
TRCI	Transmit RAI-CI—Remote Alarm Indication at the H2TU-R (Net signal does not have errors.)	Upon reception of an RAI (yellow) from the CPE, the H2TU-R sends RAI-CI towards the network if the network signal received at the H2TU-R is clear. If the network signal is impaired (LOS, AIS, or LOF), then the RAI is passed on to the network unaltered.
TUC	Transmission Unit Central Office	Accompanies the DBER, HBER, MAL, and LA alarm and indicates that the alarm has occurred at the H2TU-C central office unit.
TUR	Transmission Unit Remote End	Accompanies the DBER, HBER, MAL, and LA alarm and indicates that the alarm has occurred at the H2TU-R remote unit.

Continued

Table 2. Front-Panel Display Messages (Continued)

Message	Full Name	Description
LOOPBACK MESSAGES		
CLOC	Customer Local Loopback	DS1 signal from customer is looped back to the customer at the H2TU-R.
CREM	Customer Remote Loopback	DS1 signal from customer is looped back to the customer at H2TU-C.
NLOC	Network Local Loopback	DSX-1 signal is looped back to the network at the H2TU-C.
NREM	Network Remote Loopback	DSX-1 signal is looped back to the network at the H2TU-R.
SMJK	Remote SmartJack Loopback	DSX-1 signal is looped back to the network at the H2TU-R SmartJack module.
DIAGNOSTIC MESSAGES		
A = xx	Maximum Loop Attenuation	The Attenuation (A) message appears followed by xx, where xx is the loop attenuation of the longest (maximum loss) span measured in dB.
ACQ	Acquisition	The multiplexers of the H2TU-C and H2TU-R are trying to establish synchronization over the HDSL2 loop.
ARM	HiGain System Armed	Armed to respond to Intelligent Repeater Loop (ILR) codes.
BAD RT?	No Response from H2TU-R	The H2TU-C does not receive any response from the H2TU-R. Therefore, the integrity of the H2TU-R or the HDSL2 loop is questionable.
FERR	Framing Bit Error Occurred	Framing bit error occurred at H2TU-C DSX-1 input.
FLDL	Flash Download	Flash download of firmware upgrades. Contact Customer Service for upgrade procedures (see "Appendix D - Product Support" on page 63.)
HES	HDSL2 CRC Error	H2TU-C HDSL2 Loop Cyclical Redundancy Check (CRC) error.
LBPV	Local Bipolar Violation	A bipolar violation has been received at the DSX-1 input to the H2TU-C-231.
M=xx	HDSL2 Loop Margin	Indicates the power of the received HDSL2 signal relative to noise (S/N with respect to 21.5 dB). Any value of 6 dB or greater is adequate for reliable system operation.
MNGD	Managed	The H2TU-C-231 is under control of the H2TU-319 network management unit. In this state, the front-panel craft port and pushbuttons are disabled.
PWR FEED OFF	Power Feed Off	HDSL2 span power has been turned off by setting the PWFD option to OFF, or HDSL2 span power has been turned off by use of the A2LB Intelligent Office Repeater (IOR) powerdown code.
PWR FEED ON	Power Feed On	Indicates that the HDSL2 loop is not grounded or shorted.
SIG	Signaling	The transceivers of the H2TU-C and H2TU-R are trying to establish contact with each other over the HDSL2 loop.
SYSTEM INFORMATION MESSAGES ^(a)		
CODE xxxx	Line Code: AMI, B8ZS	DS1 line code: Alternate Mark Inversion (AMI) or Bipolar with 8-Zero Substitution (B8ZS).
FRM xxxx	Frame: SF, ESF, UNFR	Defines the type of frame pattern being received from the DSX-1: SuperFrame (SF), Extended SuperFrame (ESF), or Unframed (UNFR).
LATT xx	Loop Attenuation	Current loop attenuation threshold setting is measured in dB.
LIST xx	List Number	List number of the H2TU-C-231.
MARG xx	Margin	Current margin threshold setting is measured in dB.
VER x.xx	Software Version Number	Software version number of the H2TU-C-231.

(a) System information messages are displayed in Scroll mode. To scroll through the messages, press the MODE pushbutton for 3 or more seconds.

INSTALLATION



Upon receipt of the equipment, inspect the contents for signs of damage. If the equipment has been damaged in transit, immediately report the extent of damage to the transportation company and to ADC.

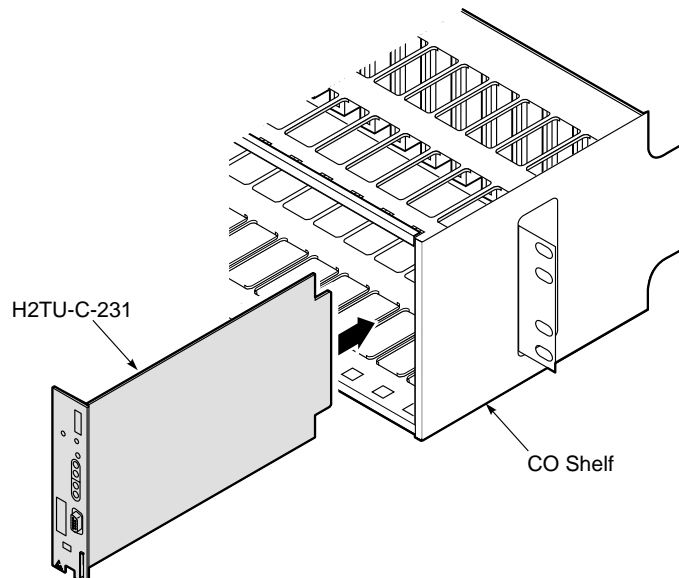

Figure 2. Installing the H2TU-C-231 List 4E into a Shelf



When installing an H2TU-C-231 in a chassis, be sure to wear an antistatic wrist strap. Avoid touching components on the circuit board.



To comply with the intrabuilding wiring requirements of GR-1089 CORE, Section 4.5.9, the shields of the ABAM-type cables that connect the H2TU-C-231 List 4E DSX-1 output ports to the cross-connect panel must be grounded at both ends.

- 1 Align the H2TU-C with the enclosure slot guides and slide the unit in. Push the unit back until it touches the backplane card-edge connector, and the retaining latch on the front panel opens.
- 2 Place your thumbs on the front panel and push the H2TU-C into the card-edge connector until the retaining latch closes. This indicates that the card is properly seated.

VERIFICATION

Once the H2TU-C-231 is installed, verify that it is operating properly. To do this, monitor the following:

- Status LED
- Status messages reported by the front-panel display ([Table 2 on page 5](#)).

Verification without an H2TU-R Remote Unit

If there is no H2TU-R remote unit installed:

- 1 Verify that the H2TU-C powers up. The front-panel display illuminates and reports status messages. (See [Table 2 on page 5](#) for a list of messages.)
- 2 Verify that the H2TU-C attempts to communicate with a remote unit (status LED flashes red). Even if a remote unit is not present, the following events should occur:
 - a The front-panel display reports various four-character status messages.
 - b The H2TU-C again attempts communication with a remote unit until a remote unit is detected.

Verification with an H2TU-R Remote Unit

If an H2TU-R remote unit has been installed:

- 1 Verify that the H2TU-C powers up. (The front-panel display illuminates and reports various status messages.)
- 2 Verify that the H2TU-C attempts to communicate with the remote unit (status LED flashes red). One of the following occurs:
 - If the remote unit is successfully identified and the HDSL2 loop synchronizes, the H2TU-C status LED lights a steady green. The H2TU-C reports normal margin messages on the front-panel display.
 - If the remote unit is not identified, the H2TU-C reports four-character status messages. The H2TU-C attempts communication again and reports four-character status messages. The H2TU-C repeats this cycle until a remote unit is detected.
- 3 Verify that a valid DS1 signal has been applied to the H2TU-C and the H2TU-R.
 - If no DS1 signal is being applied to either the H2TU-C or the H2TU-R inputs, then the appropriate DS1 alarms (LLOS or RLOS) display on the front panel and the status LED flashes red.
 - If a valid DS1 signal is being supplied to the H2TU-C and H2TU-R, then DS1 alarm indications should be absent and the status LED should be a steady green.

PROVISIONING

There are two methods for provisioning:

- Use the MODE and SEL pushbuttons on the front panel of the H2TU-C to:
 - Set system options
 - Reset the H2TU-C to its factory default settings for system options
 - Display system option settings (Scroll mode)
 - Select system loopbacks
- Use a maintenance terminal (ASCII terminal or a PC running terminal emulation software) connected to the H2TU-C craft port (or to an HMU craft port) to access the maintenance screens (see [Figure 3 on page 12](#)). This gives you full access to all H2TU-C status, history, inventory, and provisioning screens.



No dip switches or jumpers are required to provision the H2TU-C-231 as it contains a non-volatile RAM (NVRAM) which stores the system option settings. System option settings are retained if shelf power is lost or the H2TU-C-231 is unplugged.

USING THE MODE AND SEL PUSHBUTTONS

Setting Options through MODE and SEL

To provision the H2TU-C-231 List 4E through the MODE and SEL pushbuttons on the front panel:

- 1 Press the MODE pushbutton for 1 second and release it. The front-panel display alternately shows the first system parameter and its current setting.
- 2 Press the SEL pushbutton to step through all possible settings of the selected parameter.
- 3 After the desired setting has been selected, press the MODE pushbutton. This updates the currently displayed parameter to the selected setting, then advances to the next configurable parameter. After the last parameter has been selected, a CONF NO message appears on the front-panel display.
- 4 Do one of the following:
 - To cancel the session without saving the requested parameter changes, press the MODE pushbutton or do nothing. (After 30 seconds, the display returns to its normal mode without saving the new changes.)
 - To accept the requested parameter changes, press the SEL pushbutton. (A CONF YES message appears and returns to its normal mode after saving the new changes.)

Resetting to Factory Defaults

All user options for the H2TU-C-231 List 4E ([Table 6 on page 18](#)) can be set to the factory default values using the MODE and SEL pushbuttons. To set the user options to their default values:

- 1 Press the SEL pushbutton for 6 seconds until the following message appears:

DFLT NO

- 2 Press the SEL pushbutton while the DFLT NO message is displayed.

The message changes to DFLT YES indicating the factory default values are now in effect and the display returns to the normal mode.

To terminate the DFLT mode without setting the factory default values, do one of the following:

- Press the MODE pushbutton to return to the normal display mode.
- Wait 30 seconds for the unit to return to the normal display mode.

Displaying System Parameter Settings

To scroll through the current settings of all system parameters, press the MODE pushbutton for 3 or more seconds. The H2TU-C displays the following parameters:

- Software version number
- List number
- Type of frame pattern received from the DSX-1
- Line code of the signal received from the DSX-1
- All user-configured parameter settings
- Loop attenuation threshold setting
- Margin alarm threshold setting

Disabling an Alarm

System alarms can be disabled by pressing the SEL pushbutton on the H2TU-C-231 front panel. This executes an ACO and returns the H2TU-C-231 to its non-alarm state. For more information, see [“Retiring System Alarms” on page 45](#).

Loopback Modes

See [“Loopback Operation” on page 47](#) for instructions on using the MODE and SEL pushbuttons to activate loopbacks.

USING A MAINTENANCE TERMINAL

Connecting to a Maintenance Terminal

The craft port on the front panel allows you to connect the H2TU-C-231 List 4E to a maintenance terminal (ASCII terminal or PC running a terminal emulation program). Once connected to a maintenance terminal, you can access the maintenance, provisioning, and performance screens.

To connect to a maintenance terminal:

- 1 Connect a standard 9-pin terminal cable to the RS-232 craft port (Figure 1 on page 3) on the H2TU-C-231 List 4E front panel.
- 2 Connect the other end of the cable to the serial port on the maintenance terminal.
- 3 Start a terminal emulation program such as Procomm (emulating a VT100 terminal).
- 4 Configure the maintenance terminal to the following communication settings:
 - 9600 baud
 - No parity
 - 8 data bits
 - 1 stop bit
 - Hardware flow control to OFF
- 5 If necessary, press **CTRL** + **R** to refresh the logon screen.

Logon Screen

The maintenance terminal screens allow you to monitor, provision, and troubleshoot an H2TU-C-231 system.

To select a menu from the logon screen (Figure 3 on page 12), do one of the following:

- Press the underlined letter of the menu.
- Use the **←** **→** arrow keys to select the menu, and then press **ENTER**.

Table 3 summarizes the navigational keys. They are also listed in the onscreen Help menu. Table 4 on page 12 describes the Logon screen menus.

Table 3. *Navigational Keys for the Maintenance Terminal Screens*

Key ^(a)	Function
SPACEBAR	Cycle through selections.
ENTER	Activate the current setting or choice, or display a menu.
ESC or F11 (VT100 only)	Return to the parent menu.
↑ or CTRL + E	Select the submenu or item above the current one, or return to the previous menu.
↓ or CTRL + X	Select the submenu or item below the current one.
→ or CTRL + D	Select the menu or item to the right of the current one.
← or CTRL + S	Select the menu or item to the left of the current one, or return to the previous menu.
CTRL + R	Refresh the screen.

(a) Legacy management units require use of control keys instead of arrow keys.



Most VT100 emulation programs support a print screen option. For Windows-based programs, such as Procomm or HyperTerminal, see the Help menu for instructions.

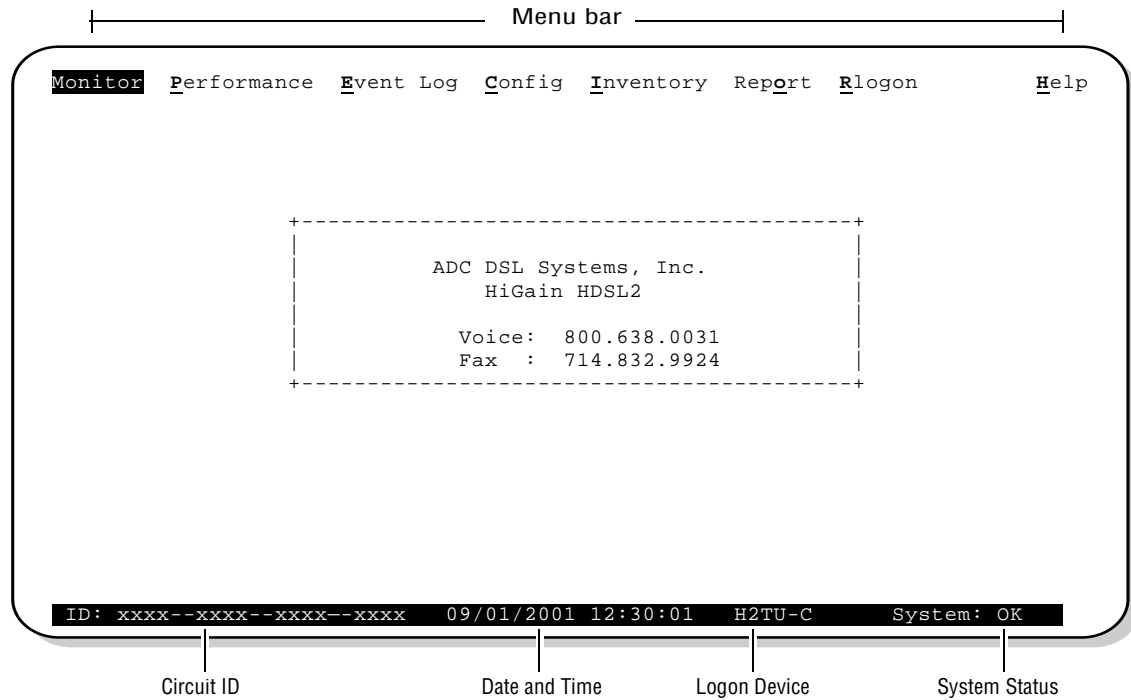

Figure 3. Logon Screen

Table 4. Logon Screen Menus

Press this key:	To access this menu:	Menu Functions
M	Monitor	Monitors loopbacks and alarms, and provides a graphical representation of circuit activity, including ES, UAS, SES, and line code.
P	Performance	Provides performance and alarm histories for current, 25-hour, 48-hour, or 31-day periods for either the DS1 or HDSL2 interface.
E	Event Log	Identifies the 100 most recent system events and reports the origin, date and time of occurrence, and message.
C	Config	Provides standard configuration options, ADC options, date and time setting, and a reset option (factory settings). Also provides a master clear option that clears all performance, alarm, and event log entries.
I	Inventory	Provides product information about the various devices that are in the system and lists circuit and device identifications.
O	Report	Provides four types of reports: Full Report, Short Report, System Information Report, and Event Report.
R	Rlogon / Rlogout	Remote log on can be performed from the H2TU-C or H2TU-R. The screen displays "Rlogout" when the H2TU-C or H2TU-R is remotely logged on to the other unit at the end of the circuit. To log off the remote unit, press R . "Rlogout" changes to "Rlogon". The unit is now locally logged on until R is pressed again to reinitiate the remote log on.
H	Help	Provides a glossary of terms used in the maintenance screens, a list of navigational keys, print guide, and ADC contact information.

PROVISIONING TASKS

After H2TU-C-231 is successfully installed, perform these basic provisioning tasks.

- 1 Set the date and time (see “Setting Date and Time” on this page).
- 2 Set the circuit ID number (see “Setting Circuit ID Numbers” on page 14).
- 3 Make any configuration changes (see “Configuring the System” on page 15).
- 4 Clear history, alarm, and event log screens to remove miscellaneous data during startup (see “Clearing the History, Alarm, and Event Log Screens” on page 26).

Setting Date and Time

```

Monitor  Performance  Event Log  Config  Inventory  Report  Rlogon      Help
-----+-----+
| Standard Options -> |
| ADC Options       -> |
| Date and Time   -> |
+-----+-----+
| Date (mm/dd/yyyy): 09/01/2001 |
| Time (hh:mm[:ss]): 12:30:01  |
+-----+-----+
ID: xxxxx--xxxx--xxxx--xxxx  09/01/2001 12:30:01  H2TU-C  System: OK

```

Figure 4. Config Menu - Date and Time

- 1 Press **C** to select the Config menu.
- 2 Use the **↑** and **↓** arrow keys to select **Date and Time**, then press **ENTER**.
- 3 Type the date in the format indicated, then press **ENTER**.
- 4 Type the time in the format indicated (entering seconds is optional), then press **ENTER**.

Setting Circuit ID Numbers

The Inventory screen provides product information on all units in the system and allows the setting of the circuit and unit identification numbers.

```

Monitor  Performance  Event Log  Config  Inventory  Report  Rlogon      Help
-----
----- Product Information -----
Unit      : H2TU-C          H2TU-R
Product   : H2TU-C-231     H2TU-R-402
List      : 4E             6E
Sw Ver.   : 2.10           2.10
Build #   : 10             10
Checksum  : 0x7CDD         0x7CDD
H2 Xcvr   : L1-RA2 1.31   L1-RA2 1.31
Serial #  : 01232456789   0123456789
CLEI     : VACJDLHEAAA   VAR1AAAAAAA
Mfg. Date: 07/28/2000    07/28/2000

----- Circuit and Unit Identifications -----
Circuit ID   : xxxx--xxxx--xxxx--xxxx
H2TU-R ID   : yyyy--yyyy--yyyy--yyyy
Circuit Notes:

ID: xxxx--xxxx--xxxx--xxxx 09/01/2001 12:30:01 H2TU-C System: OK

```

Figure 5. Inventory Screen

- 1 Press **I** to select the Inventory screen.
- 2 Type the Circuit ID number, then press **ENTER**.
- 3 Type the ID numbers of all other devices listed in the system, pressing **ENTER** after each entry.

Configuring the System

The Config menu (Figure 6) allows you to make the following types of system configuration changes:

- Standard options (Figure 7 on page 16)
- ADC options (Figure 8 on page 16)
- Date and time (see “Setting Date and Time” on page 13)
- Master clear (see “Clearing the History, Alarm, and Event Log Screens” on page 26)
- Reset to factory default configuration, described in “Resetting to Factory Defaults” on page 10

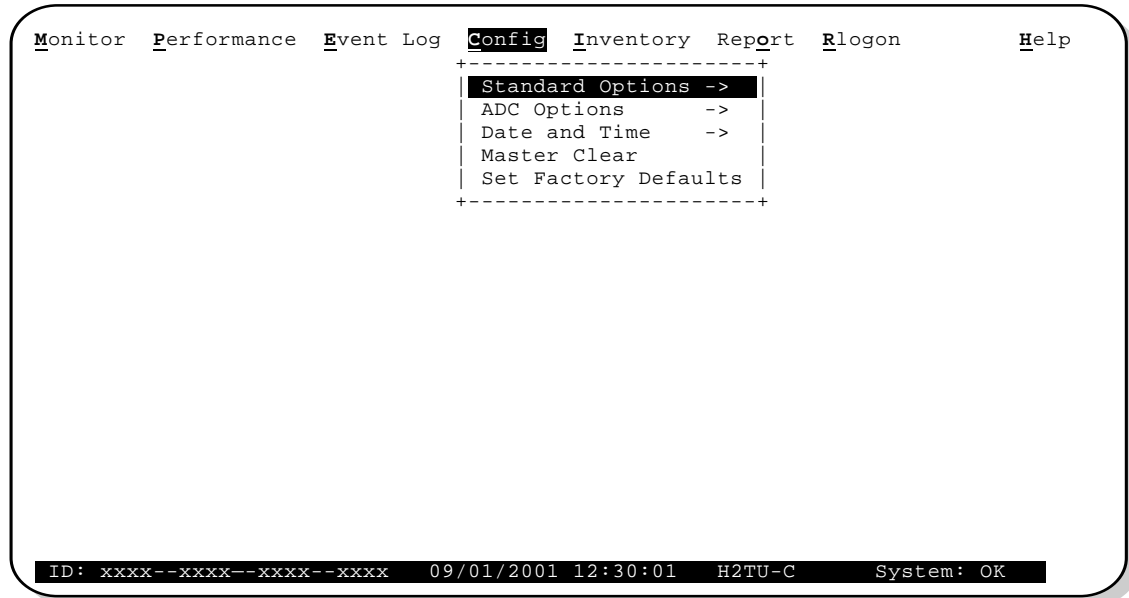

Figure 6. Config Menu

Making Changes to Standard and ADC Options

Figure 7 and Figure 8 on page 16 show the Standard and ADC configuration options. Standard options are those that are supported by HiGain HDLSL2 units when connected to units from other vendors. ADC options are an extended set of options that are only available when using HiGain units exclusively. For a description of each option and a list of possible option settings, refer to Table 5 on page 17 and Table 6 on page 18. To make changes to these options:

- 1 Press **C** to select the Config menu.
- 2 Use the **↑** and **↓** arrow keys to select **Standard Options** or **ADC Options**, then press **ENTER**.
- 3 Use the arrow keys to select an option.
- 4 Press the **SPACEBAR** to cycle through the available settings for that option.
- 5 Press **ENTER** to activate your choice.

```

Monitor  Performance  Event Log  Config  Inventory  Report  Rlogon      Help
+-----+
| Standard Options -> |
+-----+
| Loopback Timeout (LBTO)                : 120 min |
| Loop Attenuation Threshold (LATT) [0-40]: 32 dB |
| Margin Threshold (MARG)                 [0-15]: 5 dB |
| DS1 Frame Formatting (FRMG)             : AUTO |
| DS1 Line coding (DS1)                  : B8ZS |
| H2TU-C Equalization (EQL)               : EXT |
| H2TU-R Line Buildout (RLBO)             : -7.5 dB |
| Alarm Pattern (ALMP)                   : AIS |
| H2TU-R TLOS Loopback (TLOS)            : DIS |
| Network Loopback Pattern (NLBP)        : AIS |
| Power Back Off Customer (PBOC)         : DEF |
| Power Back Off Network (PBON)          : DEF |
+-----+
Use <Spacebar> to cycle through option settings and <Enter> to activate
ID: xxxx--xxxx--xxxx--xxxx 09/01/2001 12:30:01 H2TU-C System: OK
    
```

Figure 7. Config Menu - Standard Options (defaults shown)

```

Monitor  Performance  Event Log  Config  Inventory  Report  Rlogon      Help
+-----+
| Standard Options -> |
| ADC Options -> |
+-----+
| Line Power Feed (PWRP)                  : ON |
| Remote Provisioning (RTPV)              : ENA |
| Bipolar Violation Transparency (BPVT)   : DIS |
| DS1 BER (DBER)                         : DIS |
| HDSL2 BER Threshold (HBER)              : 1E-6 |
| Special Loopback Mode (SPLB)            : GNLB |
| SmartJack Loopback (LPBK)               : ENA |
| Minor Alarm (ALM)                       : DIS |
| Network AIS Signal (NAIS)                : CI |
| Performance Report Messaging (PRM)      : S+N |
| SF-RAI to SF-RAI-CI toward NET (RACI)  : ENA |
| ESF-RAI to SF-RAI Overwrite (ROVR)     : ENA |
| H2TU-R DS1 Frame Conversion (CONV)     : OFF |
| Fractional T1 Mode (FT1)                : DIS |
+-----+
Use <Spacebar> to cycle through option settings and <Enter> to activate
ID: xxxx--xxxx--xxxx--xxxx 09/01/2001 12:30:01 H2TU-C System: OK
    
```

Figure 8. Config Menu - ADC Options (defaults shown)

Table 5 below describes the Standard Config menu options and Table 6 on page 18 describes the ADC Config menu options. Selections in bold type are the factory default settings.

Table 5. H2TU-C-231 List 4E Standard Config Menu Options

Standard Config Menu Options	Front-Panel Display Code	Selection	Description
Loopback Timeout	LBTO	NONE	Disables automatic time-out cancellation of all loopbacks.
		20	Sets automatic cancellation of all loopbacks to 20 minutes after initiation.
		60	Sets automatic cancellation of all loopbacks to 60 minutes after initiation.
		120	Sets automatic cancellation of all loopbacks to 120 minutes after initiation.
Loop Attenuation Threshold	LATT	0 through 40 dB	Determines the maximum loop attenuation before an alarm is declared. Zero disables the alarm. The loop attenuation threshold can only be set through the maintenance screens.
		32 dB	Default value.
Margin Threshold	MARG	0 to 15 dB	Determines the minimum allowable margin below which a system alarm can occur. Zero disables the alarm. The Margin (Alarm) Threshold can only be set through the maintenance screens.
		5 dB	Default value.
DS1 Frame Formatting	FRMG	AUTO	Configures the HiGain HDSL2 system to operate in an auto-framing (AUTO) mode in which it continuously searches the input DS1 bit stream for a valid SF or ESF frame pattern. Both line and path performance parameters are maintained. Unframed payloads will cause the ES-P and SES-P counters to increment.
		UNFR	Configures the HiGain HDSL2 system to operate in an unframed mode. This mode disables the auto framing process and forces the system to function as a transparent bit pipe. Only line parameters are considered when monitoring DS1 performance.
DS1 Line Coding	DS1	B8ZS	Places both the H2TU-C and H2TU-R into their B8ZS modes.
		AMI	Places both the H2TU-C and H2TU-R into their AMI modes.
H2TU-C Equalization See "H2TU-C Equalization (EQL) Option." on page 20.	EQL	EXT	Disables the H2TU-C internal equalizer, allowing connection of external equalizer hardware.
		0	Sets the Equalizer to DSX-1 for 0 to 132 feet.
		133	Sets the Equalizer to DSX-1 for 133 to 265 feet.
		266	Sets the Equalizer to DSX-1 for 266 to 398 feet.
		399	Sets the Equalizer to DSX-1 for 399 to 532 feet.
		533	Sets the Equalizer to DSX-1 for 533 to 655 feet.
H2TU-R Line Buildout	RLBO		Sets the DS1 receive level output toward the Customer Interface (CI).
		0 dB	Sets the DS1 RLBO level toward the CI to 0 dB.
		-7.5 dB	Sets the DS1 RLBO level toward the CI to -7.5 dB.
		-15.0 dB	Sets the DS1 RLBO level toward the CI to -15.0 dB.
Alarm Pattern See "Alarm Pattern (ALMP) Option." on page 20.	ALMP	AIS	Enables the HiGain HDSL2 system to output an AIS payload at its DS1 ports for LOSW and LOS DS1. For priority resolution, see Figure 26 on page 46.
		LOS	Enables the HiGain HDSL2 system to output an LOS condition at its DS1 ports for LOSW and LOS DS1.
H2TU-R TLOS Loopback	TLOS	ENA	Enables a logic loopback at the H2TU-R when an LOS occurs at its DS1 input, if enabled at the H2TU-R. For priority resolution, see Figure 26 on page 46.
		DIS	Disables Transmit Loss of Signal (TLOS) logic loopback.

Continued

Table 5. H2TU-C-231 List 4E Standard Config Menu Options (Continued)

Standard Config Menu Options	Front-Panel Display Code	Selection	Description
Network Loopback Pattern	NLBP	AIS	Enables the H2TU-R to transmit an AIS towards CI for any network loopback. For priority resolution, see Figure 26 on page 46 .
		LOS	Enables the H2TU-R to transmit an LOS towards CI for any network loopback.
Power Back Off Customer See “Power Back Off Customer (PBOC) and Power Back Off Network (PBON) Options” on page 20 .	PBOC	DEF	Configures the power output levels of the H2TU-R customer unit towards the network to comply with the Default template as defined in Section 6.1.4.2 of ANSIT1.E1.4.
		ENH	Configures the power output levels of the H2TU-R customer unit towards the network to comply with the Enhanced template as defined in Section 6.1.4.2 of ANSIT1.E1.4.
Power Back Off Network See “Power Back Off Customer (PBOC) and Power Back Off Network (PBON) Options” on page 20 .	PBON	DEF	Configures the power output levels of the H2TU-C network unit towards the customer to comply with the Default template as defined in Section 6.1.4.2 of ANSIT1.E1.4.
		ENH	Configures the power output levels of the H2TU-C network unit towards the customer to comply with the Enhanced template as defined in Section 6.1.4.2 of ANSIT1.E1.4.

Table 6. H2TU-C-231 List 4E ADC Config Menu Options

ADC Config Menu Options	Front-Panel Display Code	Selection	Description
Line Power Feed	PWRP	OFF	Disables powering to the HDSL2 pair.
		ON	Keeps the HDSL2 line voltage at nominal -180 Vdc.
Remote Provisioning	RTPV	ENA	Enables remote provisioning.
		DIS	Disables remote provisioning.
Bipolar Violation Transparency See “Bipolar Violation Transparency (BPVT) Option” on page 20 .	BPVT	ENA	Enables BPVs and HDSL2 CRC errors at the DS1 input to be converted into DS1 BPVs at the DS1 output at the distant end. This makes HiGain HDSL2 transparent to BPVs.
		DIS	Disables BPV Transparency.
DS1 BER Threshold See “DS1 BER (DBER) Option” on page 21 .	DBER	ENA	Enables the fixed 24-hour DS1 BER threshold.
		DIS	Prevents the generation of a system alarm due to DS1 BER.
HDSL2 BER Threshold See “HDSL2 BER Threshold (HBER) Option” on page 21 and “System Alarm Output Pins” on page 59 .	HBER	1E-6	System alarm relay contact closes and the Status LED flashes red when the Block Error Rate exceeds 10^{-6} . (Block Error Rate is based on the definition of Bit Error Rate.)
		1E-7	System alarm relay contact closes and the Status LED flashes red when BER exceeds 10^{-7} .
		NONE	Prevents generation of a system alarm due to BER.

Continued

Table 6. H2TU-C-231 List 4E ADC Config Menu Options (Continued)

ADC Config Menu Options	Front-Panel Display Code	Selection	Description
Special Loopback Mode	SPLB	GNLB	Configures the HiGain HDSL2 system to respond to the generic in-band loopback codes.
		A2LB	Configures the HiGain HDSL2 system to respond to the in-band loopback codes of the Teltrend addressable repeater.
		A3LB	Configures the HiGain HDSL2 system to respond to the in-band loopback codes of the Wescom addressable repeater.
		A4LB	Configures the HiGain HDSL2 system to respond to the in-band loopback codes of the Wescom Mod 1 addressable repeater.
SmartJack Loopback	LPBK	ENA	Enables the HiGain HDSL2 system to recognize all in-band SmartJack (SMJK) loopback commands.
		DIS	Configures the HiGain HDSL2 system to ignore all in-band SmartJack loopback commands.
Minor Alarm	ALM	ENA	Enables the generation of the output alarm on pins 20 and 21 when a system alarm condition occurs.
		DIS	Disables the generation of the output alarm on pins 20 and 21 when a system alarm condition occurs.
Network AIS Pattern	NAIS	CI	If ALMP is set to AIS, this option specifies which pattern is sent to the network when a remote LOS or AIS occurs. When configured for CI, an AIS-CI pattern is sent to the network. For priority resolution, see Figure 26 on page 46 .
		AIS	When configured for AIS, an AIS pattern is sent to the network.
Performance Report Messaging	PRM	SPRM	The H2TU-R generates Supplemental PRM (SPRM) every second if no PRM is present from the CPE within 5 seconds of a reset or an LOS/AIS/OOF condition occurs. TL1 commands and responses are enabled.
		NPRM	The H2TU-R generates Network PRM (NPRM) if no PRM is present from the CPE. If the CPE is sending PRMs, NPRM is generated, in addition to the existing PRM, every second. TL1 commands and responses are enabled.
		S + N	The H2TU-R generates an NPRM which is tagged on to an SPRM every second. The H2TU-R generates SPRM if no PRM is present from the CPE. If the CPE is sending PRM, the PRM is converted to an SPRM. TL1 commands and responses are enabled.
		OFF	ESF Datalink (DL) is completely transparent. No PRMs are generated. There are no TL1 responses unless the system is first armed by a TL1 command, which enables Performance Monitoring.
SF-RAI to SF-RAI-CI towards NET See “SF-RAI to SF-RAI-CI toward NET (RACI) Option” on page 21.	RACI	ENA	Allows DS1 SF-RAI (yellow alarm) signal received by the H2TU-R to be converted to an SF-RAI-CI signal towards the network.
		DIS	Prevents conversion of the DS1 SF-RAI to an SF-RAI-CI signal. It does not prevent RAI to RAI-CI conversion for ESF payloads or SF-RAI-CI to ESF-RAI-CI from occurring when FCON is active.
ESF-RAI to SF-RAI Overwrite See “ESF-RAI to SF-RAI Overwrite (ROVR) Option” on page 22.	ROVR	ENA	If the CONV option is set to FCON or ACON, an ESF DS1 payload from the network with an embedded RAI pattern is converted to an SF-RAI pattern towards the CI at the H2TU-R.
		DIS	Prevents conversion to an SF-RAI pattern.
H2TU-R DS1 Frame Conversion See “H2TU-R DS1 Frame Conversion (CONV) Option” on page 22.	CONV	OFF	Framing determined by the DS1 frame formatting option.
		ACON	Auto (ACON) detection of framing and potential frame conversion at the remote.
		FCON	Auto detection of framing and forced frame format conversion (FCON) at the H2TU-R.

Continued

Table 6. H2TU-C-231 List 4E ADC Config Menu Options (Continued)

ADC Config Menu Options	Front-Panel Display Code	Selection	Description
Fractional T1 Mode See “Fractional T1 Mode (FT1) Option” on page 24.	FT1	ENA	Enables system response to DDS latching loopback commands for fractional T1 applications, CP disconnect, and trouble indication. For priority resolution, see Figure 26 on page 46.
		DIS	Disables system response to DDS latching loopback commands for fractional T1 applications, CP disconnect, and trouble indication.

H2TU-C Equalization (EQL) Option. The equalizer shapes the DS1 output signal of the H2TU-C to conform to a very specific pulse template when it arrives at the DSX-1 cross-connect point. The degree of pulse-shaping required is a function of the distance between the H2TU-C equipment bay and the DSX-1 panel. Thus, the equalizer has six discrete settings, in increments of 133 feet to cause the maximized separation of 635 feet.

Alarm Pattern (ALMP) Option. To improve HiGain HDSL2 compatibility with the switch-to-protect features used in Digital Loop Carrier (DLC) feeder applications, the H2TU-C-231 has an Alarm Pattern (ALMP) option that allows you to select either an AIS or LOS DS1 output payload for the following alarms:

- LOSW on any loop
- LOS DS1

Power Back Off Customer (PBOC) and Power Back Off Network (PBON) Options. Power Back Off Customer (PBOC) and Power Back Off Network (PBON) allow the HDSL circuit to support two transmit power templates: default (DEF/higher level) and enhanced (ENH/lower level). These are defined in Section 6.1.4.2 of the ANSI T1E1.4 HDSL2 standard. Each HDSL2 receiver detects the level it is receiving during the start-up, pre-activation sequence. It then compares this level to the level it should be receiving according to the PBOC and PBON option settings (DEF or ENH). If the received level is outside the template limits, the receiver sends a message to the upstream HDSL2 transmitter requesting the proper level. These levels are adjusted only during the start-up routine or if the PBOC or PBON option settings are changed during normal operation. Since the ENH template levels are up to 15 dBm below those of the DEF template, the ENH setting can be used to reduce crosstalk levels into adjacent circuits. (For example, if crosstalk noise is being induced by the H2TU-R, set the PBOC option to its lower (ENH) level setting. Conversely, if the HDSL2 signal at the H2TU-R is being affected by crosstalk noise induced from adjacent pairs, set the PBOC option to its higher (DEF) level setting.



Changing these Power Back Off option settings on a live circuit causes the HDSL2 loop to momentarily drop and then reacquire synchronization. This setting can also affect the operating margins.

Bipolar Violation Transparency (BPVT) Option. The H2TU-C-231 improves compatibility with Digital Loop Carrier (DLC) feeder applications because of its ability to transmit DS1 BPV occurrences between its DS1 interfaces. This feature is required to support protection switching in DLC applications. Each DLC terminal must be able to monitor the integrity of its Receive DS1 payload and then switch to the protect line when the integrity of the path drops below specific user selected limits. An essential requirement of this feature is the need for each DLC terminal to detect BPVs in its DS1 input. Standard HDSL systems correct DS1 BPVs at the input and, therefore, prevent them from being detected by the DLC terminals to which they are connected. The H2TU-C-231 and its associated remote units remove this limitation and become BPV transparent by detecting and counting input BPVs at each end and then by replicating them at the DS1 output port of the distant end.

The BPV count is converted into BPVs at the distant end during the following second at a rate of 1 BPV every 128 DS1 bits up to a maximum of 12000 (BER = 7.7×10^{-3}). This maximum rate is more than adequate since it exceeds the maximum 10^{-3} BER required by most DLC systems.

DS1 BER (DBER) Option. The DS1 BER alarm occurs when any of the DS1 or DSX-1 performance monitoring parameters listed in Table 7 exceed the counts shown for the 24-hour period between 12:00:00 AM through 11:59:59 PM. These thresholds correspond to a 10^{-6} BER. All PM counters clear to zero at 12:00:00 AM or when Master Clear is selected.

Table 7. DS1 and DSX-1 24-Hour PM Threshold

Parameter	Threshold Count
CV-L (BPV)	133,400
ES-L, ES-P, PRM, PDVS-L	648
SES-L, SES-P	100
UAS-P, UAS-L	10

HDSL2 BER Threshold (HBER) Option. The HBER option permits the monitoring of loop integrity and reporting of alarms when excessive errors are detected. The PM primitive used for this purpose is the CRC checksum performed on the HDSL2 frame for both directions of transmission. It is, therefore, called a block error rate rather than the bit error rate associated with the DS1 interface. The CRC errors and counts are displayed on the Monitor screen for both the H2TU-C and H2TU-R. The HBER option allows an alarm to be generated if the total number of CRCs at either the H2TU-C or H2TU-R exceeds the selected BER threshold during the last 1-minute interval.

- HBER option = 1E-6. Alarm is generated if CRC > 93
- HBER option = 1E-7. Alarm is generated if CRC > 9

Once initiated, the HBER count clears when the CRC count drops below the selected threshold. Selecting NONE inhibits this alarm.

SF-RAI to SF-RAI-CI toward NET (RACI) Option. In general, the Remote Alarm Indication - Customer Installation (RAI-CI) signal is an RAI signal which contains a signature indicating that an LOF or AIS failure has occurred within the customer's network.

RAI-CI is transmitted toward the network when these two conditions are simultaneously true at the point from which RAI-CI is originated (at the H2TU-R, towards the network):

- RAI is received from the CI
- No LOF, LOS, or AIS failure is detected in the signal received from the network.

Since RAI-CI meets the definition of RAI, RAI-CI may be detected and used exactly as an RAI.

For ESF, the RAI-CI signal is a repetitive pattern with a period of 1.08 seconds. RAI-CI is formed by sequentially interleaving 0.99 seconds of the unscheduled message 00000000 11111111 (right-to-left), which represents RAI in the DL, with 90 milliseconds of the message 00111110 11111111 (right-to-left) to flag the signal as RAI-CI.

For SF, the SF-RAI-CI signal is transmitted in-band by setting each of the 24 channel time slots to 1000 1011 (left-to-right). In addition to the criteria specified above, the generation of SF-RAI-CI has to be held for 1 second to examine the DS0 channels for the presence of a frame with an all-zeros pattern. If present, the generation of SF-RAI-CI is suspended for the duration of the all-zeros pattern.

In all SF environments, the H2TU-R automatically converts a CPE DS1 payload with an embedded RAI signal into an RAI-CI pattern towards the network if the RACI option is enabled (default). Such a conversion affects the payload as described above. Disable RACI to avoid this conversion.



The SF-RAI to SF-RAI-CI option is only applicable in an all SF framing environment. If SF to ESF conversion is active (the CONV option is set to either ACON or FCON), the SF-RAI is converted into ESF-RAI in the FDL, regardless of the RACI setting.

ESF-RAI to SF-RAI Overwrite (ROVR) Option. If the ESF-RAI to SF-RAI Overwrite (ROVR) option is enabled, it allows a network ESF-RAI or ESF-RAI-CI pattern to be converted into a CPE SF-RAI or SF-RAI-CI pattern.

If the ROVR option is disabled, it prevents conversion of a network ESF payload with an embedded RAI pattern. Disabling the ROVR option preserves the integrity of the CPE payload as it was originally transmitted.

H2TU-R DS1 Frame Conversion (CONV) Option. Frame format conversion is only applicable to the remote H2TU-R, but selectable by the H2TU-C or H2TU-R. This option enables the network to be ESF, which is used to embed SPRM or NPRM into the datalink towards the network. During conversion, frame bit errors are regenerated to ensure transparency.

The HDSL2 system attempts to find ESF or SF framing or determines that no framing exists. The DS1 framing is then synchronized with the HDSL2 frame. If the framing is lost, the system generates an Out-of-Frame (OOF) defect which results in Unavailable Seconds - Path (UAS-P). As a result, the system reverts to frame search mode.

This option has the following settings:

- **OFF:** No frame conversion takes place. All framing issues are determined by the FRMG option settings of AUTO and UNFR.
- **ACON:** This is the automatic conversion setting. If the system detects ESF from the network and SF from the CPE, it automatically converts the CPE SF to ESF towards the network as well as the network ESF to SF towards the CPE.

Upon power-on-reset, after loopdown, or after changing the frame conversion option, the framing needs to be re-established before a complete conversion takes place. If there is a failure condition (LOS, AIS, or LOF) during steady state, the previous conversion state is maintained to ensure continuity when the system returns from the failure condition.

If SF is received from the network, the H2TU-R forces an ESF towards the network for about 1.5 seconds. This signals to the far-end PM-NIU at the network boundary that frame conversion is requested. If the far-end PM-NIU is capable of conversion, it changes the framing to ESF. If not, then the H2TU-R reverts to SF and does not apply any conversion.

If an ESF is received from the CPE, it is passed on to the network, and the network's inbound framing is passed on to the CPE.

- **FCON:** This is the forced conversion setting. [Table 8](#) lists the HiGain HDSL2 responses to both the ACON and FCON settings for the CONV option. The responses are identical, except in cases 3 and 4. In these cases, the FCON reply is attempting to force the network (or the far-end PM-NIU) to send ESF. It also alerts the CPE with an AIS alarm pattern while forcing the ESF to the network. Continuity is maintained as for ACON. [Table 9 on page 23](#) and [Table 10 on page 24](#) list the ESF and SF frame formats, respectively.

Table 8. Response to H2TU-R DS1 Frame Conversion Options

Case Number	NET Transmit	CPE Transmit	ACON Option	FCON Option
			NET > CPE NET < CPE	NET > CPE NET < CPE
1	ESF	SF	ESF → SF ESF ← SF	ESF → SF ESF ← SF
2	ESF	ESF	ESF → ESF ESF ← ESF	ESF → ESF ESF ← ESF
3	SF	ESF	SF → SF ESF ← ESF	SF → AIS ESF ← ESF
4	SF	SF	SF → SF SF ← SF	SF → AIS ESF ← SF

Table 9. Extended SuperFrame Format

ESF Number	Frame Bits		
	Framing Pattern Sequence (FPS) - 2 kb/s	Frame Bit for Datalink (FDL) - 4 kb/s	Cyclical Redundancy Check (CRC) Bits - 2 kb/s
1		m	
2			C1
3		m	
4	0		
5		m	
6			C2
7		m	
8	0		
9		m	
10			C3
11		m	
12	1		
13		m	
14			C4
15		m	
16	0		
17		m	
18			C5
19		m	
20	1		
21		m	
22			C6
23		m	
24	1		

Table 10. SuperFrame Format

SF Number	Frame Bits	
	Terminal Framing Bit	SuperFrame Signaling Bit
1	1	
2		0
3	0	
4		0
5	1	
6		1
7	0	
8		1
9	1	
10		1
11	0	
12		0

Fractional T1 Mode (FT1) Option. Fractional T1 circuits can be used in feeder networks to provide frame relay service. If such circuits are maintained by a DDS test group, then these circuits must respond to DDS/DS0 latching loopback commands, the only tool test groups have at their disposal. A latching loopback, once it has been initiated by the correct sequence, remains locked or “latched” until the correct loopdown sequence has been detected.

The FT1 option, when enabled, allows the H2TU-C to respond to DS0 latching loopback commands and, therefore, support fractional T1 frame-relay applications. This is in addition to the standard full bandwidth T1 2-in-5 loopup and 3-in-5 loopdown SmartJack commands. FT1 supports both the full T1 commands of ENA and the new DDS latching loopback commands, which must also be enabled. (For more information about latching loopback commands, refer to BellCore TA-TSY-000077, Issue 3, April 1986.)

The FT1 option supports both the DDS NI and DDS DS0 Data Port (DP) latching loopback sequences listed in [Table 11](#).

Table 11. DDS NI and DS0 DP Latching Loopback Sequence

Enable Sequence	Minimum Number of Bytes	Byte Name	Network Code
1	35	Transition in Progress (TIP)	S0111010
2A	35	NI Loop Select Code (LSC)	S1000001
2B	35	DS0 DP Loop Select Code (LSC)	S0000101
3	100	Loopback Enable Code (LBE)	S1010110
4	35	All Ones	S1111111
5	100	LBE	S1010110
6	32	Far End Voice (FEV)	S1011010
Disable/Loopdown	35	TIP	S0111010

The sequences in [Table 11](#) are sent in time slot 1. The S in the Network Code column is a “don’t care” bit. The loopback is activated after the detection of Sequence 6. Upon completion of the enable sequence, the Test Center continues to transmit FEV bytes in multiples of 20 until FEV confirmation bytes are returned, or until about 2 seconds have elapsed. If the confirmation bytes are not received, a failed attempt is reported. Anticipate the

minimum number of bytes when the loopback code is transmitted by a pre-programmed machine test pattern generator. These minimum number of bytes will most likely be exceeded when the codes are sent manually. Also, manual testing may inject random data signals between valid control sequences. The detection algorithm ignores these occurrences and only responds to valid control codes.

Table 12 lists the relationship between the latching loopback sequences and the specific HiGain HDSL2 loopback they initiate.

Table 12. *HiGain HDSL2 Loopback vs. Latching Sequence*

HiGain HDSL2 Loopback	Latching Sequence
NREM	1, 2A, 3, 6
NLOC	1, 2B, 3, 6

The NLOC loopback is called tandem DS0 DP loopback. It is used to select one of many loopback points when there are several identical data ports in tandem. The NI loopback is assigned to the H2TU-R (NREM) since it is usually located at the Network Interface (NI). The DS0 DP tandem loopback is assigned to the rest of the HiGain HDSL2 loopbacks because most DDS test sets support this tandem command set.

The Test Center transmits a group of 40 TIP bytes to loop down the loopback. It continues to transmit TIP bytes in multiples of 20 until the TIP bytes are not returned or until about 2 seconds have elapsed. If the bytes are absent, a successful loopdown is reported; otherwise, a failed loopdown is reported. The loopdown can also be initiated by depressing the H2TU-R loopback control pushbutton or by any of the standard 3-in-5 loopdown commands. The implemented detection or release loopback algorithm functions properly in the presence of a 10^{-3} bit error rate.

Since the FT1 mode is a combination of both the full T1 and the latching loopback modes, all codes are always active. Therefore, if a loopback is initiated by a latching sequence, it can be looped down by either a latching or generic loopback and vice versa. All loopback commands are completely symmetric in the FT1 mode.

If the latching sequence shown in Table 12 is interrupted for more than 20 minutes, the detection is cleared, and the H2TU-C reverts back to its initial state where it searches for the initial sequence 1.

After a successful latching sequence terminates in a latched loopback state, the state remains until the Disable command is detected, or until the LBTO option of NONE, 20, 60, or 120 minutes has expired, whichever occurs first.

The unframed AIS pattern that is normally sent towards the network for a CILOS fault condition must be replaced by the new patterns listed in Table 13 when the FT1 loopback option is selected.

Table 13. *Response of H2TU-C and H2TU-R to LOS and AIS*

Case	FT1 Option	H2TU-C Input	H2TU-C Output Pattern			H2TU-R Input	H2TU-R Output	Status Screen	Front-Panel Display
			Framing	Payload	FDL				
1	ENA	SF	SF	01111110	N/A	LOS/AIS	01111110 UNFR	RCV RLOS/RAIS XMT IDLE	ALRM RLOS/RAIS
2	ENA	ESF	ESF	01111110	X ^(a)	LOS/AIS	01111110 UNFR	RCV RLOS/RAIS XMT IDLE	ALRM RLOS/RAIS
3	ENA	LOS/AIS	SF	01111110	N/A	LOS/AIS	01111110 UNFR	RCV RLOS/RAIS XMT IDLE	ALRM RLOS/RAIS

Continued

Table 13. Response of H2TU-C and H2TU-R to LOS and AIS (Continued)

Case	FT1 Option	H2TU-C Input	H2TU-C Output Pattern			H2TU-R Input	H2TU-R Output	Status Screen	Front-Panel Display
			Framing	Payload	FDL				
4	ENA	LOS/AIS	SF	PL	X ^(a)	SF/PL	AIS	RCV LLOS/LAIS	ALRM LLOS/LAIS
5	ENA	LOS/AIS	ESF	PL	X ^(a)	ESF/PL	AIS	RCV LLOS/LAIS	ALRM LLOS/LAIS

(a) Don't care bit.

Resetting the H2TU-C



Resetting the H2TU-C to its original factory settings may cause interruption of service.

To reset the H2TU-C-231 List 4E to its original factory defaults:

- 1 Press **C** to select the Config menu (see Figure 9).
- 2 Use the **↑** and **↓** arrow keys to select **Set Factory Defaults**, then press **ENTER**.
- 3 Press **Y** if you are certain you want to reset the H2TU-C, or press **N** to cancel this action.

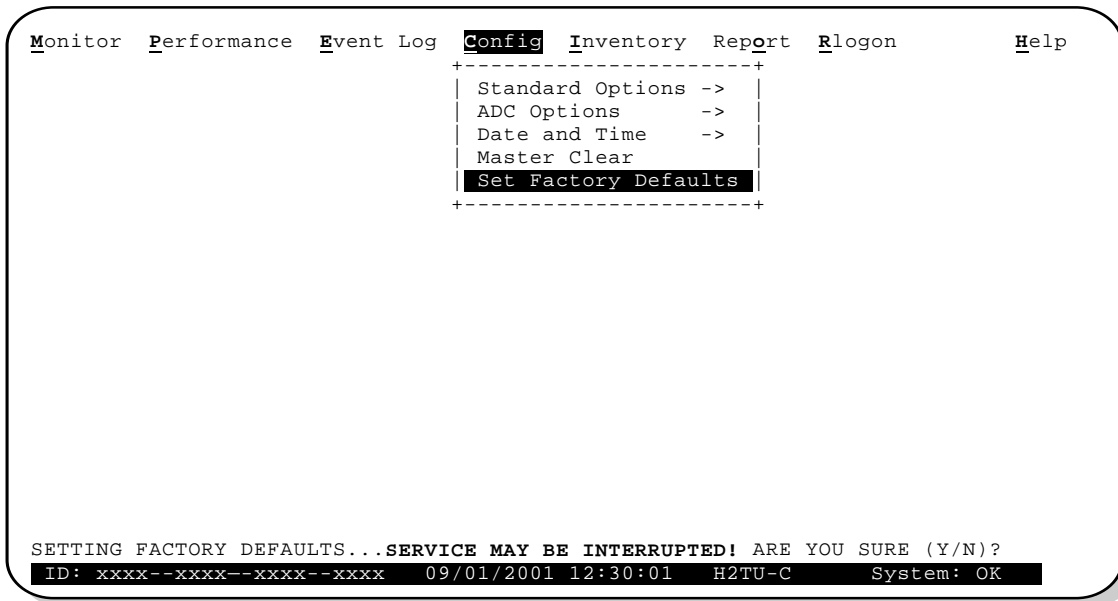

Figure 9. Config Menu - Set Factory Defaults

Clearing the History, Alarm, and Event Log Screens

Select Master Clear to clear the History, Alarm, and Event Log screens after the system has been installed and is functioning properly. This removes miscellaneous data acquired during the startup session and ensures collection of accurate and meaningful data thereafter.

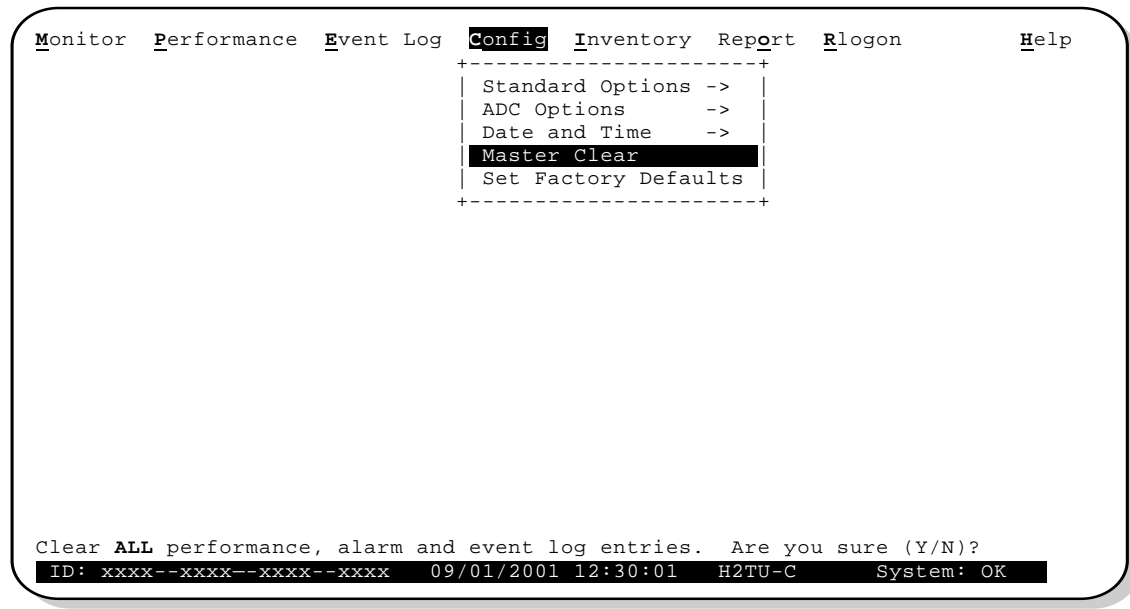

Figure 10. Config Menu - Master Clear

To clear the Event Log, press **E** to select the Event Log screen, then press **L** to clear the screen.

To clear an individual history or alarm screen, do the following:

- 1 Press **P** to select the Performance screen.
- 2 Press the **SPACEBAR** to select an interface (**H2TU-C DS1**, **H2TU-R DS1**, **H2TU-C HDSL2**, or **H2TU-R HDSL2**), then press **ENTER**.
- 3 Press the **SPACEBAR** to select the type of statistics (**Current**, **Alarm History**, **25 Hour History**, **48 Hour History**, or **31 Day History**), then press **ENTER** after your selection.
 - Selecting **31 Day History** allows you to clear the current, 25-hour, 48-hour, and 31-day performance history screens for the selected interface.
 - Selecting **Alarm History** allows you to clear the alarm history screen for the selected interface. For information about the DS1 and HDSL2 alarm screens, see [Table 17 on page 38](#).
- a Press **L** to clear the screen.

To clear ALL history, alarm, and event log screens:

- 1 Press **C** to select the Config screen.
- 2 Use the **↑** and **↓** arrow keys to select **Master Clear**.
- 3 Press **Y** to clear all screens.

MONITORING SYSTEM ACTIVITY AND PERFORMANCE

The HDSL2 system provides the following maintenance screens for monitoring system activity and assessing performance:

- The Monitor screens provide a graphical representation of circuit activity and allow initiation of loopbacks.
- The Performance screens provide current, 25-hour, 48-hour, and 31-day performance histories and a continuous alarm history.
- The Event Log screens provide a description of the 100 most recent events which include their origin, time and date of occurrence, and message.

USING THE MONITOR SCREEN TO VIEW SYSTEM ACTIVITY

1 Press **M** to view the system diagram.

Figure 11 shows an armed circuit with an active loopback and alarms. Terms used on the system diagram are defined in the onscreen Help menu glossary. Abnormal situations are highlighted on the diagram. See Table 14 on page 29 for screen field descriptions.

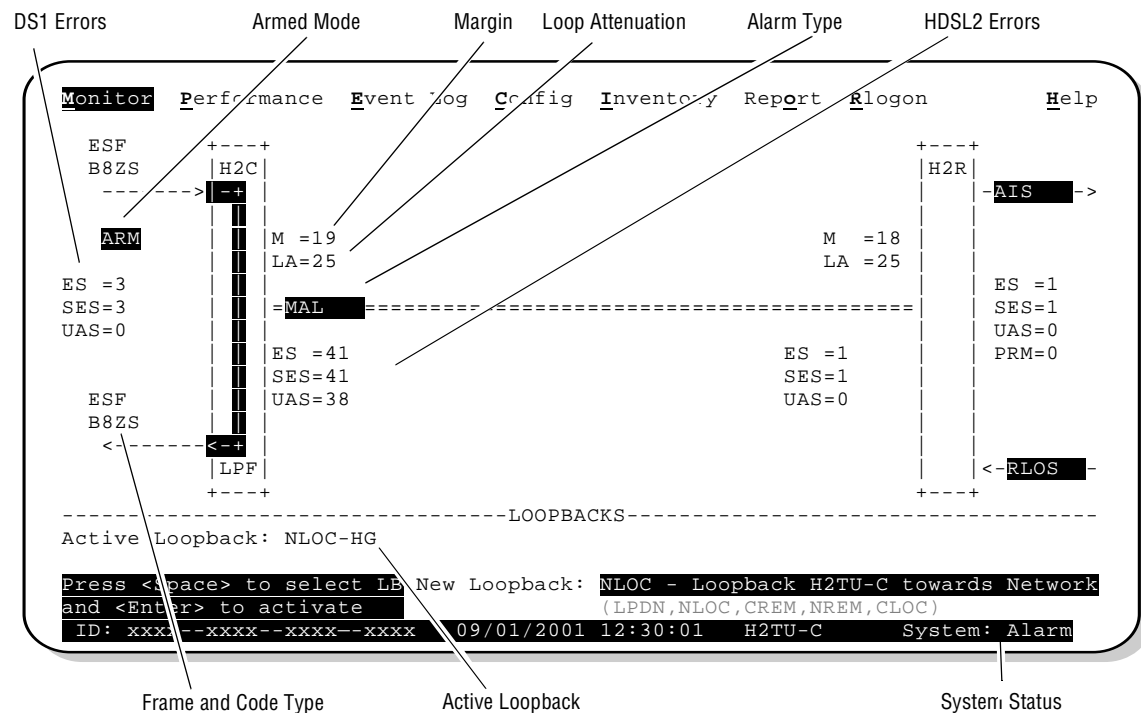

Figure 11. Monitor Screen - Active Loopback with Alarms

- 2 To initiate a loopback, press the **SPACEBAR** to cycle through the loopback choices. Press **ENTER** to make your choice.

When prompted with the message: Are you sure (Y/N)?, press **Y** to initiate the loopback or **N** to cancel. For more information about loopbacks and troubleshooting, see “Testing” on page 44.

- 3 To initiate a loopdown of all active loopbacks, press the **SPACEBAR** to select **LPDN**, then press **ENTER**. When prompted with the message: Are you sure (Y/N)?, press **Y** to initiate the loopdown or **N** to cancel.

Table 14. Monitor Screen Descriptions

Field	Description
Active Loopback	An active loopback is indicated on the lower third of the Monitor screen. Available loopbacks are indicated by gray text. See Table 22 on page 48 for a summary of the HiGain HDSL2 generic loopback codes and activation methods.
Alarm Type	Indicates type of alarm.
Armed Mode	ARM—Indicates system is in an armed state for an intelligent repeater loopback command.
Code Type	Type of DS1 line coding received or sent (B8ZS or AMI).
DS1 ES Count	Errored Seconds—The sum of the Errored Seconds - Line (ES-L) and Errored Seconds - Path (ES-P) counts detected on the DS1 input over a 24-hour period. Errors included are: DS1 frame errors, BPV, and ESF CRC errors.
DS1 SES Count	Severely Errored Seconds—The sum of the DS1 Severely Errored Seconds - Line (SES-L) and Severely Errored Seconds - Path (SES-P) counts over the last 24 hours.
DS1 UAS Count	Unavailable Seconds—The number of seconds during which the DS1 input signal was absent over a 24-hour period.
Frame type	Type of DS1 framing used on the input stream (SF, ESF, or UNFR).
HDSL2 ES Count	Errored Seconds—The number of 1-second intervals that contained at least one CRC or LOSW error. This value is a running total of the last 24 Hours.
HDSL2 SES Count	Severely Errored Seconds—The number of 1-second intervals that contain at least 50 CRC errors or one or more LOSW defects. (An LOSW defect occurs when at least three consecutive HDSL frames contain one or more frame bit errors.) This value is a running total of the last 24 hours.
HDSL2 UAS Count	Unavailable Seconds—The number of seconds the HDSL2 loop is unavailable. This occurs after 10 contiguous HDSL SES and is retired after 10 contiguous non-SES seconds. This value is a running total of the last 24 hours.
HG or (PL)	HG displays when the loopback was initiated from a HiGain (HG) front panel or by a HiGain maintenance terminal loopback command. PL displays when the loopback was initiated by a command embedded in the DS1 data path payload (PL).
ID	Circuit identification number.
LA	Loop Attenuation—Indicates the attenuation of the Overlapped Pulse Amplitude Modulation Transmission with Interlocking Spectra (OPTIS) pulse from the distant end. The value is related to the 196 kHz loss of the cable pair. The loop attenuation is a more direct indication of the loop attenuation to the OPTIS signal than is the 196 kHz loss. The normal HiGain HDSL2 LA operation range is from 0 to 40 dB.
LPF	Line Power Feed—Indicates the HDSL2 line power is on.
M	Margin—The signal-to-noise ratio at all HDSL2 ports, relative to a 10 ⁻⁷ Bit Error Rate.
MAL	Margin Alarm—Indicates the margin on HDSL2 loop has dropped below the threshold (0 to 15dB) as set by the operator.
PRM	The sum of the Performance Report Messaging-Near End (PRM-NE) and Performance Report Messaging-Far End (PRM-FE) counts.
System Status	The presence or absence of an alarm condition is indicated on the lower right corner of all screens. System: OK indicates that there are no alarms present; System: Alarm indicates the presence of an alarm. Refer to “Using the Performance Screens to View Alarm Data” on page 36.

USING THE PERFORMANCE SCREENS TO VIEW PERFORMANCE DATA

The Performance screens display:

- DS1 and HDSL2 statistics in 31-day, 48-hour, 25-hour, and current history reports.
- Alarm statistics for DS1 interfaces (Figure 21 on page 37 and Figure 22 on page 37) or the HDSL2 (Figure 23 on page 39) on a continuous basis.

To access the performance history screens:

- 1 Press **P** to select the Performance screen.
- 2 Press the **SPACEBAR** to select an interface (**H2TU-C DS1**, **H2TU-R DS1**, **H2TU-C HDSL2**, or **H2TU-R HDSL2**), then press **ENTER**.
- 3 Press the **SPACEBAR** to select the type of statistics (**Current**, **Alarm History**, **25 Hour History**, **48 Hour History**, or **31 Day History**), then press **ENTER**.

Performance History at the DS1 Interface

The Performance History for the DS1 Interface provides a 31-day, 48-hour, 25-hour, and current statistics screens for the H2TU-C and H2TU-R (as viewed from the H2TU-C). Figure 12 below and Figure 14 on page 31 are examples of DS1 performance history screens at the remote unit. Figure 13 on page 31 is an example of a DS1 performance history screen at the line unit. Refer to Table 15 on page 33 for descriptions of the errors reported on DS1 interface screens. Asterisks indicate performance monitoring from the previous day.

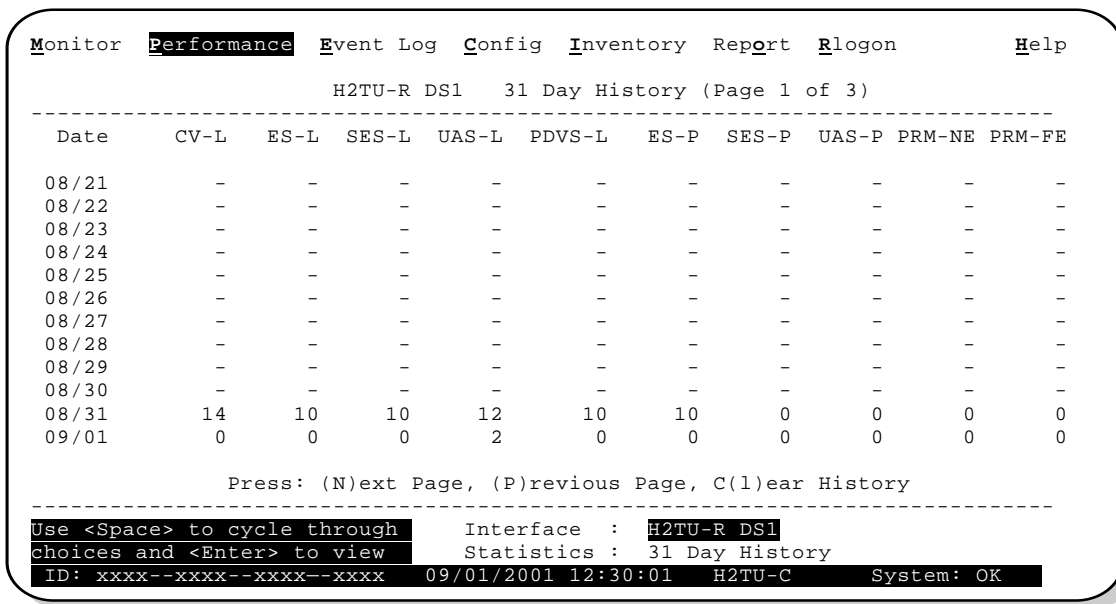

Figure 12. H2TU-R DS1 31-Day Performance History

Time	CV-L	ES-L	SES-L	UAS-L	PDVS-L	ES-P	SES-P	UAS-P
*00:00	-	-	-	-	-	-	-	-
*01:00	-	-	-	-	-	-	-	-
*02:00	-	-	-	-	-	-	-	-
*03:00	-	-	-	-	-	-	-	-
*04:00	-	-	-	-	-	-	-	-
*05:00	-	-	-	-	-	-	-	-
*06:00	-	-	-	-	-	-	-	-
*07:00	-	-	-	-	-	-	-	-
*08:00	-	-	-	-	-	-	-	-
*09:00	-	-	-	-	-	-	-	-
*10:00	-	-	-	-	-	-	-	-
*11:00	14	10	10	12	10	10	0	0

Press: (N)ext Page, (P)revious Page, C(l)ear History

Use <Space> to cycle through choices and <Enter> to view

Interface : H2TU-C DS1
Statistics : 48 Hour History

ID: xxxx--xxxx--xxxx--xxxx 09/01/2001 12:30:01 H2TU-C System: OK

Figure 13. H2TU-C DS1 48-Day Performance History

Time	CV-L	ES-L	SES-L	UAS-L	PDVS-L	ES-P	SES-P	UAS-P	PRM-NE	PRM-FE
*22:15	-	-	-	-	-	-	-	-	-	-
*22:30	-	-	-	-	-	-	-	-	-	-
*22:45	-	-	-	-	-	-	-	-	-	-
*23:00	-	-	-	-	-	-	-	-	-	-
23:15	-	-	-	-	-	-	-	-	-	-
23:30	-	-	-	-	-	-	-	-	-	-
23:45	-	-	-	-	-	-	-	-	-	-
00:00	-	-	-	-	-	-	-	-	-	-
00:15	-	-	-	-	-	-	-	-	-	-
00:30	-	-	-	-	-	-	-	-	-	-
00:45	-	-	-	-	-	-	-	-	-	-
01:00	14	10	10	12	10	10	0	0	0	0

Press: (N)ext Page, (P)revious Page, C(l)ear History

Use <Space> to cycle through choices and <Enter> to view

Interface : H2TU-R DS1
Statistics : 25 Hour History

ID: xxxx--xxxx--xxxx--xxxx 09/01/2001 12:30:01 H2TU-C System: OK

Figure 14. H2TU-R DS1 25-Hour Performance History

Examples of current statistics screens are shown below. **Figure 15** and **Figure 16** show statistics for the DS1 interface at the remote unit and line unit respectively. These screens report 1-day, 1-hour, and 15-minute statistics.

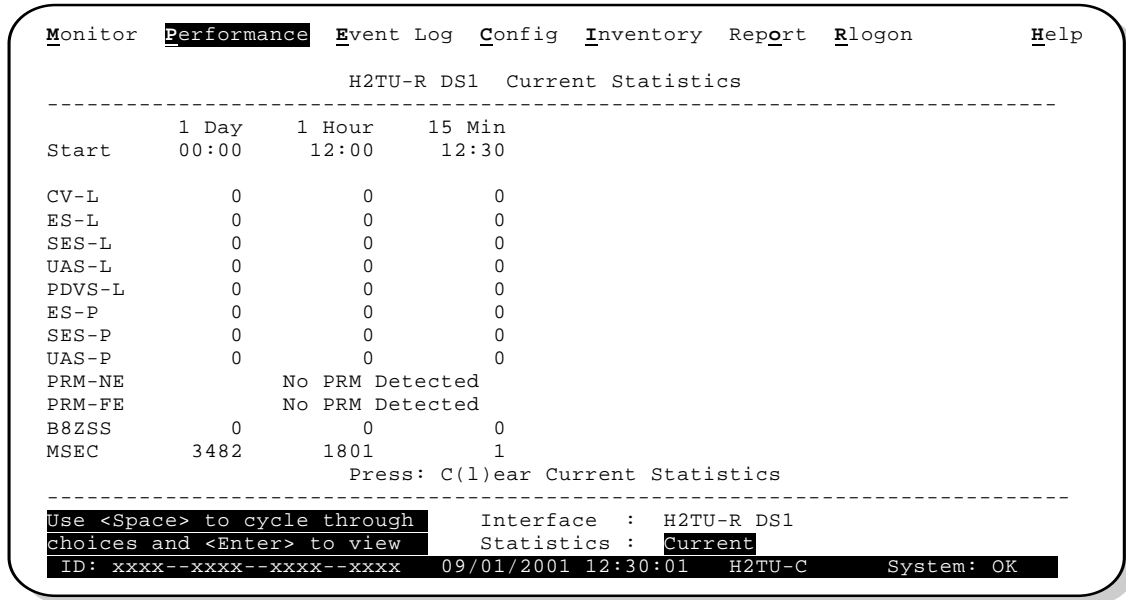

Figure 15. H2TU-R DS1 Current Statistics

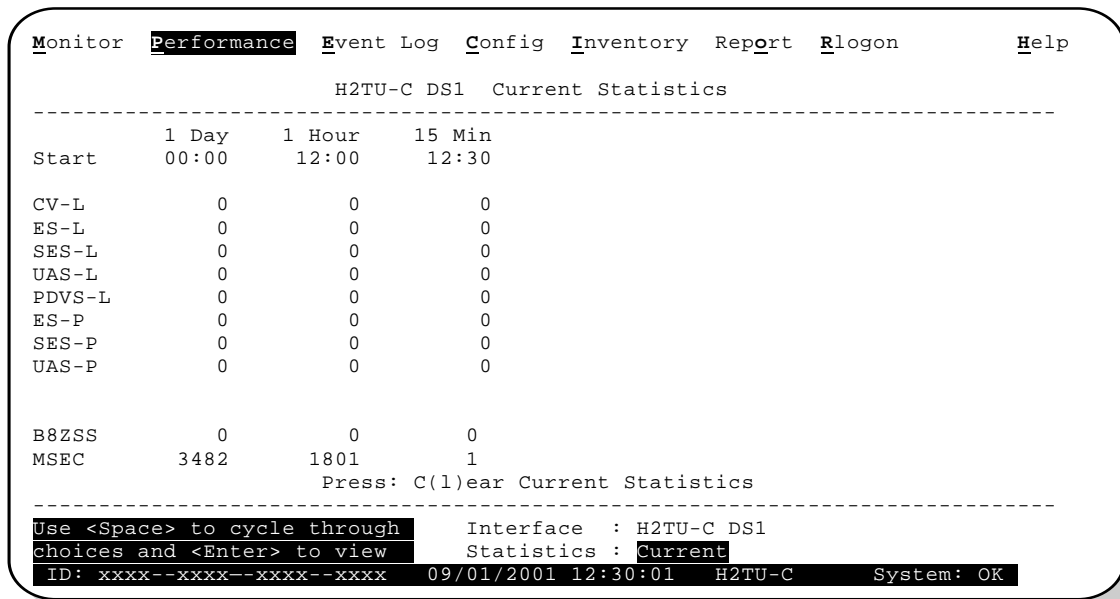

Figure 16. H2TU-C DS1 Current Statistics

Table 15. Error Acronyms Used on the DS1 Performance History Screens

Error Acronym	Description	Error Acronym	Description
CV-L	Code Violation - Line Total BPV count.	SES-P	Severely Errored Seconds - Path Seconds with SEF or CRC(ESF) ≥ 320 or FE ^(d) (SF) $\geq 8 (F_T + F_S)$.
ES-L	Errored Seconds - Line Seconds with BPV ≥ 1 .	UAS-P	Unavailable Seconds - Path A second of unavailability based on SES-P or AIS ≥ 1 .
SES-L	Severely Errored Seconds - Line Seconds with BPV plus EXZ ≥ 1544 or LOS ≥ 1 .	PRM-NE ^(a)	Performance Report Monitoring - Near End The PRM from CPE indicates errors, and the signal received from the network at the remote is error-free.
UAS-L	Unavailable Seconds - Line Seconds with LOS ≥ 1 .	PRM-FE ^(a)	Performance Report Monitoring - Far End The PRM from the network indicates errors, and the signal received from the CPE is error-free.
PDVS-L	Pulse Density Violation Seconds - Line Seconds with excessive zeros (AMI = 16 zeros, B8ZS = 8 zeros).	B8ZSS ^(b)	B8ZS Monitored Seconds Seconds with B8ZS detection when AMI option is active.
ES-P	Errored Seconds - Path Seconds with SEF ^(c) , CRC(ESF), or FE ^(d) (SF) ≥ 1 .	MSEC ^(b)	Monitored Seconds of the current (15-minute/1-hour/1-day) screen.

(a) Only displays on H2TU-R Performance History screens.

(b) Displays on the DS1 Current Statistics screens.

(c) Severely Errored Frame—Two or more frame bit errors occurring in a 0.75 ms interval for SF or a 3 ms interval for ESF.

(d) FE is a frame bit error.

Performance History at the HDSL2 Interface

The HDSL2 interface has 31-day, 48-hour, 25-hour, and current statistic screens for the H2TU-C. Figure 17 and Figure 18 below are examples of 31-day and 48-hour performance history screens. Figure 19 and Figure 20 on page 35 are examples of 25-hour and current statistics performance history screens. Refer to Table 16 on page 36 for descriptions of the kinds of errors reported on all HDSL2 performance screens. Asterisks indicate performance monitoring from the previous day.

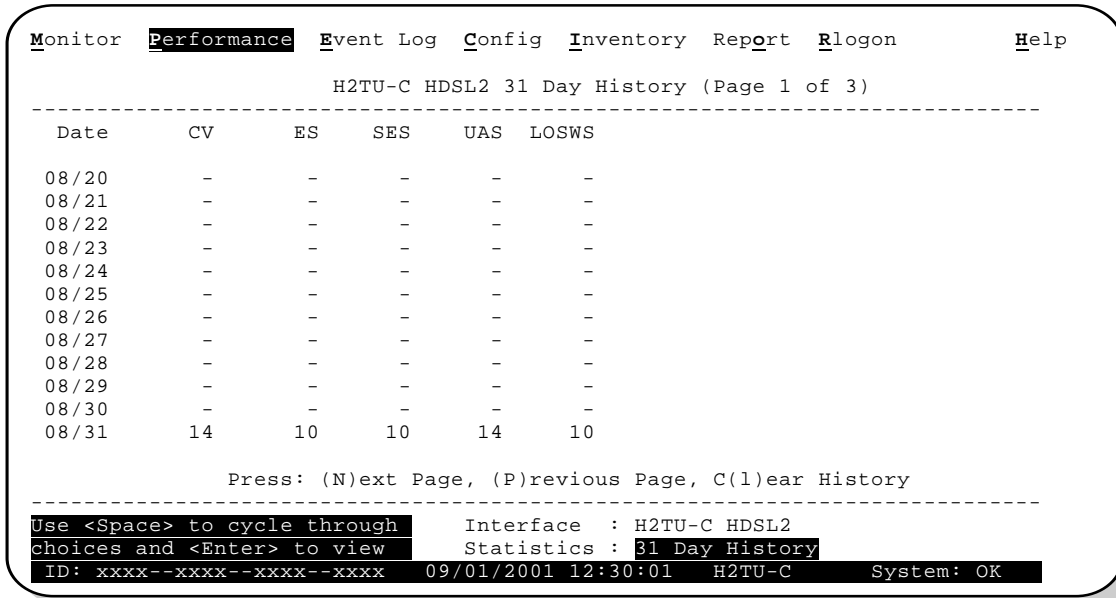

Figure 17. H2TU-C HDSL2 31-Day Performance History

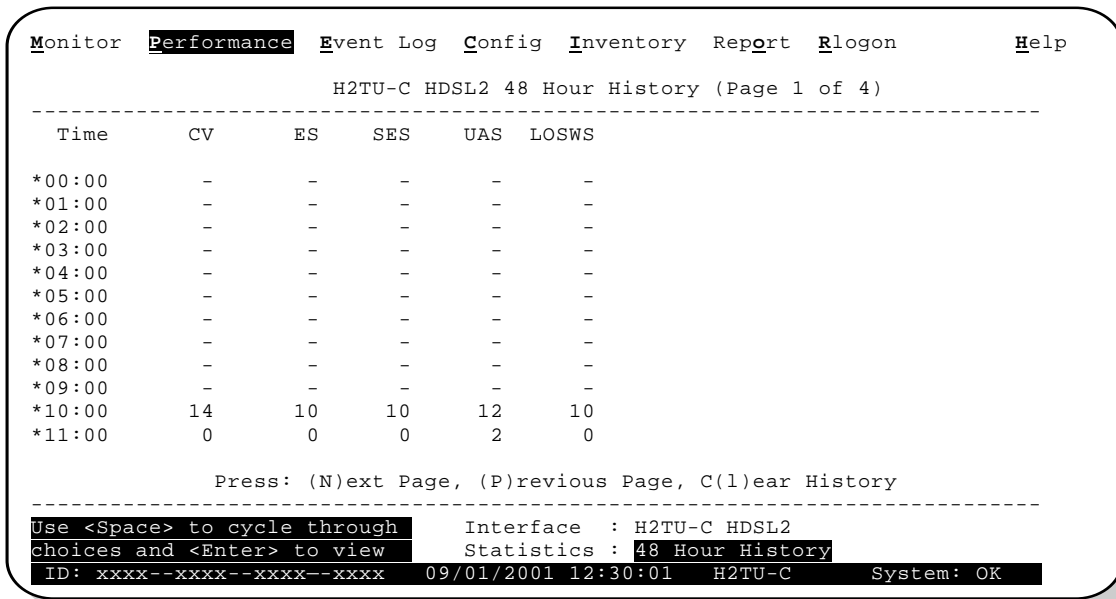

Figure 18. H2TU-C HDSL2 48-Hour Performance History

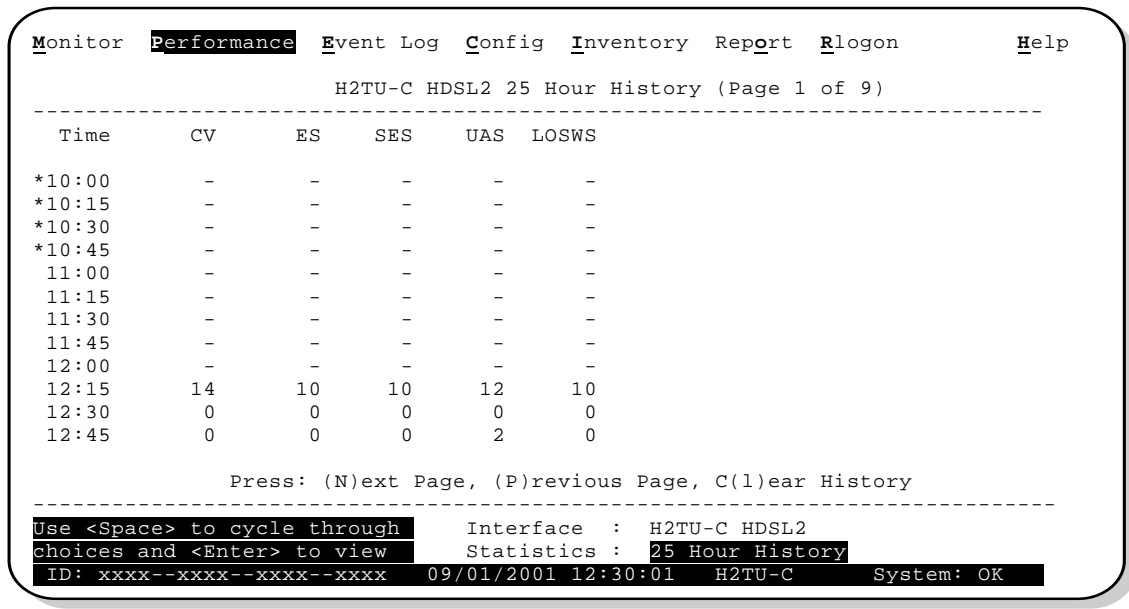

Figure 19. H2TU-C HDSL2 25-Hour Performance History

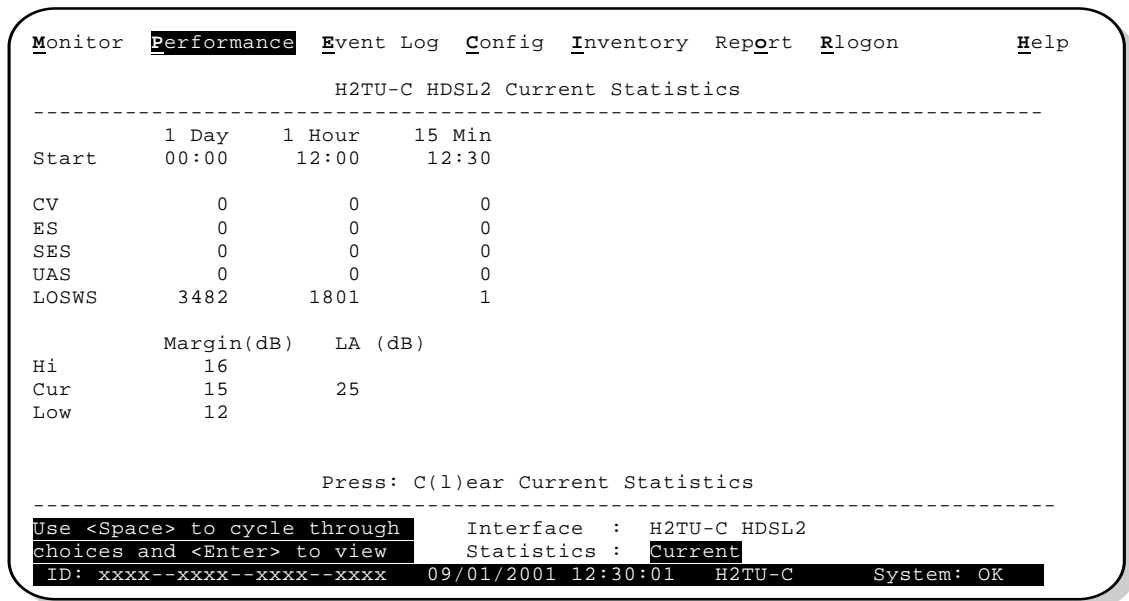

Figure 20. H2TU-C HDSL2 Current Statistics

Table 16. Error Acronyms Used on the HDSL2 Performance History Screens

Error Acronym	Description
CV	Code Violation Total count of HDSL2 CRC errors.
ES	Errored Seconds Seconds with HDSL2 CRC ≥ 1 or LOSW ≥ 1
SES	Severely Errored Seconds Seconds with HDSL2 CRC ≥ 50 or LOSW ≥ 1
UAS	Unavailable Seconds Based on 10 contiguous SES occurrences
LOSWS	Loss of Sync Word Second Seconds with LOSW ≥ 1

USING THE PERFORMANCE SCREENS TO VIEW ALARM DATA

To access the alarm history screens:

- 1 Press **P** to select the Performance menu.
- 2 Press the **SPACEBAR** to select an interface (**H2TU-C DS1**, **H2TU-R DS1**, **H2TU-C HDSL2**, or **H2TU-R HDSL2**), then press **ENTER**.
- 3 Press the **SPACEBAR** until **Alarm History** is selected, then press **ENTER**.
- 4 Press **N** or **P** to page through the alarm history screens.
- 5 Press **L** to clear the selected alarm history screen.

Alarm History at the DS1 Interface

The Alarm History screen reports DS1 statistics for the H2TU-C (Figure 21) and the H2TU-R (Figure 22 on page 37) on a continuous basis. The types of alarms reported are described in Table 17 on page 38. Current alarms are shown in reverse video.

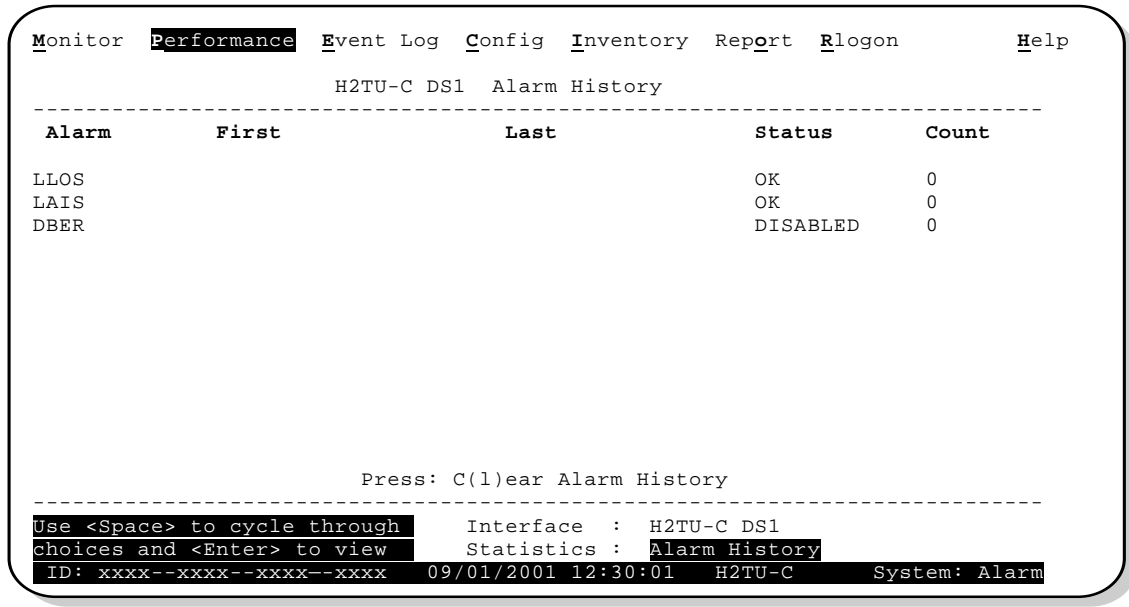

Figure 21. H2TU-C DS1 Alarm History Screen

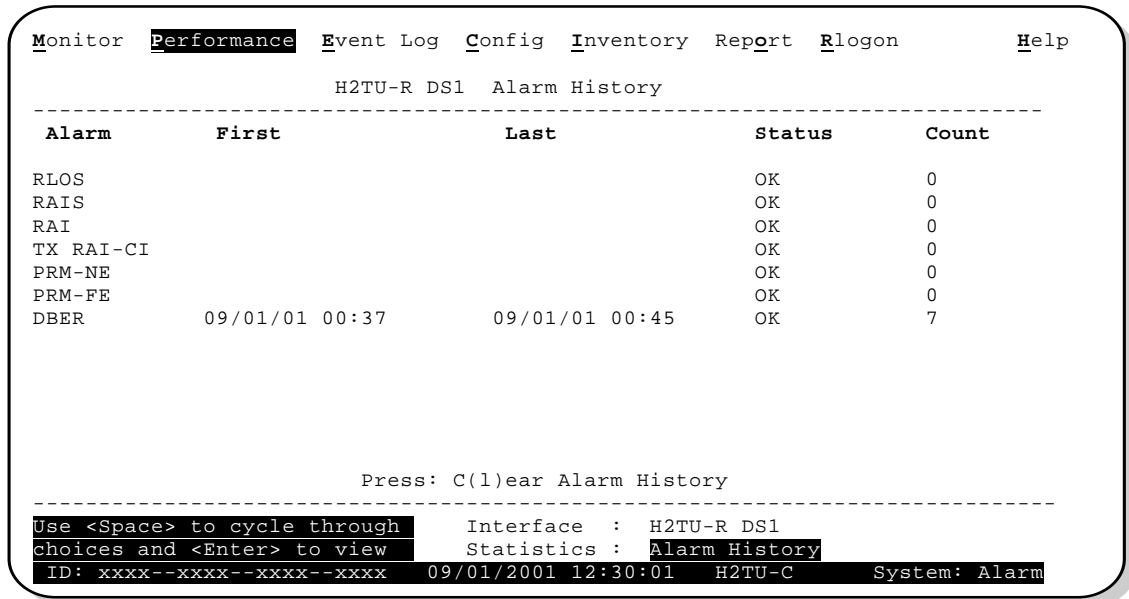

Figure 22. H2TU-R DS1 Alarm History Screen

Table 17. DS1 Alarm Descriptions

Screen Alarm	Front-Panel Alarm	Description
H2TU-C DS1 ALARMS (see Figure 21 on page 37)		
LLOS ^(a)	LLOS	Line (Unit) Loss of Signal—Loss of the H2TU-C DSX-1 input signal.
LAIS	LAIS	Line Alarm Indication Signal—Indicates an AIS (unframed all ones) pattern is being received at the H2TU-C DS1 input port.
DBER	xxx-DBER	Bit Error Rate—The DS1 BER has exceeded the built-in 24-hour threshold limits of approximately 10^{-6} . (xxx denotes either TUC or TUR.)
H2TU-R DS1 ALARMS (see Figure 22 on page 37)		
RLOS ^(a)	RLOS	Remote (Unit) Loss of Signal— Loss of the H2TU-R DS1 input signal.
RAIS	RAIS	Remote Alarm Indication Signal—Indicates an AIS (unframed all ones) pattern is being received at the H2TU-R DS1 input port. By default AIS-CI ^(b) is sent towards the network (see Figure 26 on page 46).
RAI	RRAI	Remote RAI - Remote Alarm Indication at the H2TU-R—Indicates an RAI alarm (yellow) from the CPE with errors from the line unit or network.
TX RAI-CI	TRCI	Transmit RAI-CI - Remote Alarm Indication at the H2TU-R—Upon reception of an RAI (yellow alarm) from the CPE, the H2TU-R sends an RAI-CI towards the network if the network signal received at the H2TU-R is clear. If the network signal is impaired (LOS, AIS or LOF), then the RAI is passed on to the network unaltered. This is applicable to SF or ESF framing. In an all SF environment, RACI must be enabled to convert SF-RAI to SF-RAI-CI.
PRM-NE	PRMN	Performance Report Monitoring - Near End—The count of the PRM-NE register at the H2TU-R exceeds the 10^{-6} BER threshold at 648 events since 12:00:00 AM.
PRM-FE	PRMF	Performance Report Monitoring - Far End—The count of the PRM-FE register at the H2TU-R exceeds the 10^{-6} BER threshold at 648 events since 12:00:00 AM.
DBER	xxx-DBER	Bit Error Rate—The DS1 BER has exceeded the built-in 24-hour threshold limits of approximately 10^{-6} . (xxx denotes TUR.)

(a) This is a DS1-specific alarm that also issues a minor alarm (sent to the management unit or the backplane), if enabled.

(b) AIS-CI is a modified AIS alarm pattern. Equipment not suited to detect AIS-CI still detects this signal as an AIS. AIS-CI is sent toward the network indicating that an LOS (RLOS) or AIS (RAIS) has been received from the CPE.

Alarm History at the HDSL2 Interface

Figure 23 shows the H2TU-C HDSL2 alarm history, and Table 18 describes the alarms.

```

Monitor Performance Event Log Config Inventory Report Rlogon Help
-----
H2TU-C HDSL2 Alarm History
-----
Alarm      First          Last          Status      Count
-----
LOSW
MAL
LA
HBER      09/01/01 00:37    09/01/01 00:45    OK          7
SHORT
GND
OPEN
-----
Press: C(1)ear Alarm History
-----
Use <Space> to cycle through Interface : H2TU-C HDSL2
choices and <Enter> to view Statistics : Alarm History
ID: xxxx--xxxx--xxxx--xxxx 09/01/2001 12:30:01 H2TU-C System: Alarm

```

Figure 23. H2TU-C HDSL2 Alarm History Screen

Table 18. HDSL2 Alarm Descriptions

Screen Alarm	Front-Panel Alarm	Description
HDSL2 ALARMS at the H2TU-C and H2TU-R		
LOSW	LOSW	Loss of Sync Word—The HDSL2 loop has lost synchronization.
MAL	xxx-MAL	Margin—The margin on the HDSL2 loop has dropped below the minimum threshold value set for the system. (xxx denotes either TUC or TUR.)
LA	xxx-LA	Loop Attenuation—The attenuation on the HDSL2 loop has exceeded the maximum value set for the HDSL2 loop attenuation threshold. (xxx denotes either TUC or TUR.)
HBER	xxx-HBER	Block Error Rate—The HDSL2 BER has exceeded the set threshold limits of 10^{-6} or 10^{-7} . (xxx denotes either TUC or TUR.)
HDSL2 ALARMS at the H2TU-C only		
SHORT ^(a)	PWR FEED SHRT	Indicates a short between the Tip and Ring of the HDSL2 pair.
GND ^(a)	PWR FEED GND	The HDSL2 loop is grounded.
OPEN ^(a)	PWR FEED OPEN	Indicates a line power open condition.

(a) Displays only at the H2TU-C HDSL2 interface.

USING THE SYSTEM EVENT LOG TO TRACK EVENTS

To view a running log of system events, press **E** to select the Event Log. The Event Log displays the date and time of the 100 most recent events (most recent displayed first) and provides a description of each event. See [Table 19 on page 41](#) for a complete list of event log messages.

- Press **N** or **P** to page through the event log.
- Press **T** to return to the top of the log.
- Press **L** to clear the event log.

```

Monitor Performance Event Log Config Inventory Report Rlogon Help
-----
System Event Log (Page 1 of 7)
-----
# Origin Date and Time Entry
1 System 08/19/01 12:25:00 DS1 Alarm Register reset
2 System 08/20/01 12:25:00 HDLSL2 Alarm Register Reset
3 System 08/21/01 12:25:00 DS1 Performance Register Reset
4 System 08/22/01 12:25:00 HDLSL2 Performance Register Reset
5 System 08/23/01 00:13:32 Time set 12:25:00
6 System 08/24/01 00:13:27 Date set 08/24/01
7 H2TU-C 08/25/01 00:13:27 NLOC: Loop-down
8 H2TU-C 08/26/01 00:11:16 NLOC: Loop-up
9 H2TU-R 08/27/01 00:10:43 DS1 LOS Alarm: End
10 H2TU-R 08/28/01 00:10:30 DS1 LOS Alarm: Begin
11 System 08/29/01 00:04:11 DS1C: AUTO to AMI
12 H2TU-C 08/30/01 00:00:40 HDLSL2 LOSW Alarm: End
13 H2TU-C 08/31/01 00:00:02 HDLSL2 LOSW Alarm: Begin
14 - EMPTY -
15 - EMPTY -

Press: (N)ext Page, (P)revious Page, (T)op of Log, C(l)ear Log
ID: xxxx--xxxx--xxxx--xxxx 09/01/2001 12:30:01 H2TU-C System: OK
    
```

Figure 24. System Event Log

Table 19. *Event Log Entry Messages List*

Event Log Messages
Any DS1 Alarm History reset
Any DS1 PM register reset
Any HDSL2 Alarm History reset
Any HDSL2 PM register reset
Any Loop Down (any segment)
Any Loop Up (any segment)
Any provisioning option change: <provisioning mnemonic>: changed from <old> to <new>
CPE DBER alarm (1 day threshold crossed of any PM data except PRM-NE or PRM-FE)
CPE DS1 AIS begins / ends
CPE DS1 LOS begins / ends
CPE PRM-NE BER alarm (<i>at the remote only</i> : 1 day threshold crossed of PRM-NE: trouble on CPE receive)
Current statistics reset
Event Log reset
H2TU-C Power up / down
H2TU-R Power up / down
HDSL2 DC pair open begins/ends on any segment
HDSL2 Ground fault begins/ends on any segment
HDSL2 HBER alarm (threshold crossed) on any segment.
HDSL2 loop attenuation (threshold crossed) on any HDSL2 interface
HDSL2 margin alarm (threshold crossed) on any HDSL2 interface
HDSL2 unavailability begins / ends on any segment
Master zero reset
NTWK DBER alarm (1 day threshold crossed of any PM data)
NTWK DS1 LOS begins / ends
NTWK PRM-FE BER alarm (<i>at the remote only</i> : 1 day threshold crossed of PRM-FE: trouble on NTWK far end)
NTWK DS1 AIS begins / ends
Power Feed Open begins / ends
Power Feed Short begins / ends
RAI begins / ends
TX RAI-CI begins / ends (RAI-CI sent from the remote towards the network)

USING THE REPORT MENU

The Report menu (Figure 25) provides screens containing status and performance monitoring data for line and remote units which can be downloaded to a file for analysis or future reference. Table 20 on page 43 describes the four types of reports provided by the Report menu.

To select each individual report, do the following:

- 1 Press **O** to select Report menu.
- 2 Press the **SPACEBAR** to select a report.
- 3 Use your terminal emulation software (HyperTerminal or Procomm) to capture the selected report to your printer. Press **ENTER** to generate.
- 4 End the captured report.
- 5 Press **CTRL + R** to refresh the Report menu screen.



```
Monitor  Performance  Event Log  Config  Inventory  Report  Rlogon      Help

Report Type : Full Report

Please select report type by pressing <Space>, then start terminal logging
and press <Enter> to generate the report.

ID: xxxx--xxxx--xxxx--xxxx 09/01/2001 12:30:01 H2TU-C System: OK
```

Figure 25. Report Menu - Full Report

Table 20. Report Types

Type	Contains the following information:
Full Report	<ul style="list-style-type: none">• Circuit and unit identifications• Product information• System configuration• Current performance statistics• Alarm history• Performance history
Short Report	<ul style="list-style-type: none">• Product information• System configuration• Current performance statistics
System Information Report	<ul style="list-style-type: none">• Circuit and unit identifications• Product information• System configuration
Event Report	<ul style="list-style-type: none">• Circuit and unit identifications• Product information• System event log

TESTING

This section provides information about front-panel system alarms, LOS and AIS response, OCT55 test procedure, and loopback testing.

SYSTEM ALARMS

Table 21 summarizes all possible system alarms in order of priority as they appear on the front panel. When multiple alarms occur, the front-panel display only reports the highest priority alarm. The alarm history screens display alarms also, but provide greater detail (see “Using the Performance Screens to View Alarm Data” on page 36). All alarms that are not inhibited will drive the front-panel Status LED to a flashing red alarm state.

Table 21. Front-Panel System Alarms Summary

Front-Panel Message ^(a)	Alarm	Description	To Inhibit
PWR FEED SHRT ^(b)	Power Feed Short	A short exists between the Tip and Ring of the HDSL2 pair.	Cannot be inhibited.
PWR FEED GND ^(b)	Power Feed Ground	The HDSL2 loop is grounded.	Cannot be inhibited.
PWR FEED OPEN ^(b)	Power Feed Open	A line power open condition exists.	Cannot be inhibited.
LOSW	Loss of Sync Word ^(c)	The HDSL2 loop has lost synchronization.	Cannot be inhibited.
LLOS	Line (Unit) Loss of Signal	Loss of the DSX-1 input signal.	Cannot be inhibited.
RLOS	Remote (Unit) Loss of Signal	Loss of the H2TU-R DS1 input signal.	Cannot be inhibited.
LAIS ^(d)	Line Alarm Indication Signal	Indicates an AIS (unframed all ones) pattern is being received at the H2TU-C DS1 input port.	Cannot be inhibited.
RAIS ^(d)	Remote Alarm Indication Signal	Indicates an AIS (unframed all ones) pattern is being received at the H2TU-R DS1 input port.	Cannot be inhibited.
TRCI ^(d)	Transmit RAI-CI—Remote Alarm Indication at the H2TU-R (Net signal does not have errors.)	Upon reception of an RAI alarm (yellow) from the CPE, the H2TU-R sends RAI-CI towards the network if the network signal received at the H2TU-R is clear. If the network signal is impaired (LOS, AIS, or LOF), then the RAI is passed on to the network unaltered.	Cannot be inhibited.
RRAI ^(d)	Remote RAI—Remote Alarm Indication at the H2TU-R (Net signal has errors.)	Indicates an RAI alarm (yellow) from the CPE with errors from the line unit or network.	Cannot be inhibited.
xxx-DBER ^(d)	DS1 Bit Error Rate	The DS1 BER has exceeded the set threshold limits of approximately 10^{-6} . (xxx denotes either TUC or TUR. If TUC and TUR occur at the same time, then TUC displays.)	Select DIS for the DBER system option.
PRMF ^(d)	Performance Report Messaging - Far End	Indicates H2TU-R PRM-FE BER threshold is exceeded.	Set DBER threshold to DIS.
PRMN ^(d)	Performance Report Messaging - Near End	Indicates H2TU-R PRM-NE BER threshold is exceeded.	Set DBER threshold to DIS.

Continued

Table 21. Front-Panel System Alarms Summary (Continued)

Front-Panel Message ^(a)	Alarm	Description	To Inhibit
xxx-HBER	HDSL2 Block Error Rate	The HDSL2 BER has exceeded the set threshold limits of 10^{-6} or 10^{-7} . (xxx denotes either TUC or TUR. If TUC and TUR occur at the same time, then TUC displays.)	Select NONE for the HBER system option.
xxx-MAL	Margin Alarm	The margin on the HDSL2 loop has dropped below the minimum threshold value set for the system. (xxx denotes either TUC or TUR. If TUC and TUR occur at the same time, then TUC displays.)	Set the Margin Alarm Threshold option to 0 (zero).
xxx-LA	Loop Attenuation	The attenuation on the HDSL2 loop has exceeded the maximum value set for the HDSL2 loop attenuation threshold. (xxx denotes either TUC or TUR. If TUC and TUR occur at the same time, then TUC displays.)	Set the HDSL2 Loop Attenuation Threshold option to zero.

(a) The message, ALRM, displays prior to any alarm message.

(b) Message displays repeatedly as long as the alarm condition exists and is not included in the priority order.

(c) When the HDSL2 loop loses sync word (LOSW), a system alarm condition exists. However, since the H2TU-C-231 enters the acquiring mode, the front-panel status LED flashes red, and the ACQ or SIG message displays instead of the ALRM message.

(d) Does not activate the alarm relay access pins 20 and 21.

Alarm Option for Digital Loop Carrier (DLC) Feed

To improve HiGain HDSL2 compatibility with the switch-to-protect features used in DLC feeder applications, the H2TU-C-231 has an Alarm Pattern (ALMP) option that allows you to select either an AIS or LOS DS1 output payload for the following alarms:

- LOSW on any loop
- LOS DS1

Retiring System Alarms

To retire a system alarm, press the SEL pushbutton to execute an Alarm Cutoff (ACO). An ACO turns the alarm off and replaces the ALRM message with an ACO message. The second part of the ALRM message, which defines the cause of the alarm, remains. Both parts of the message remain until the alarm condition clears or another higher priority alarm occurs.

Remote LOS and AIS Response

Figure 26 shows the different ways the H2TU-R can respond to the network, depending on the configuration of the TLOS, NLBP, FT1, AMLP, and NAIS configuration options described in Table 5 on page 17 and Table 6 on page 18. See Table 13 on page 25 for response of the H2TU-C and H2TU-R to LOS and AIS alarm conditions.

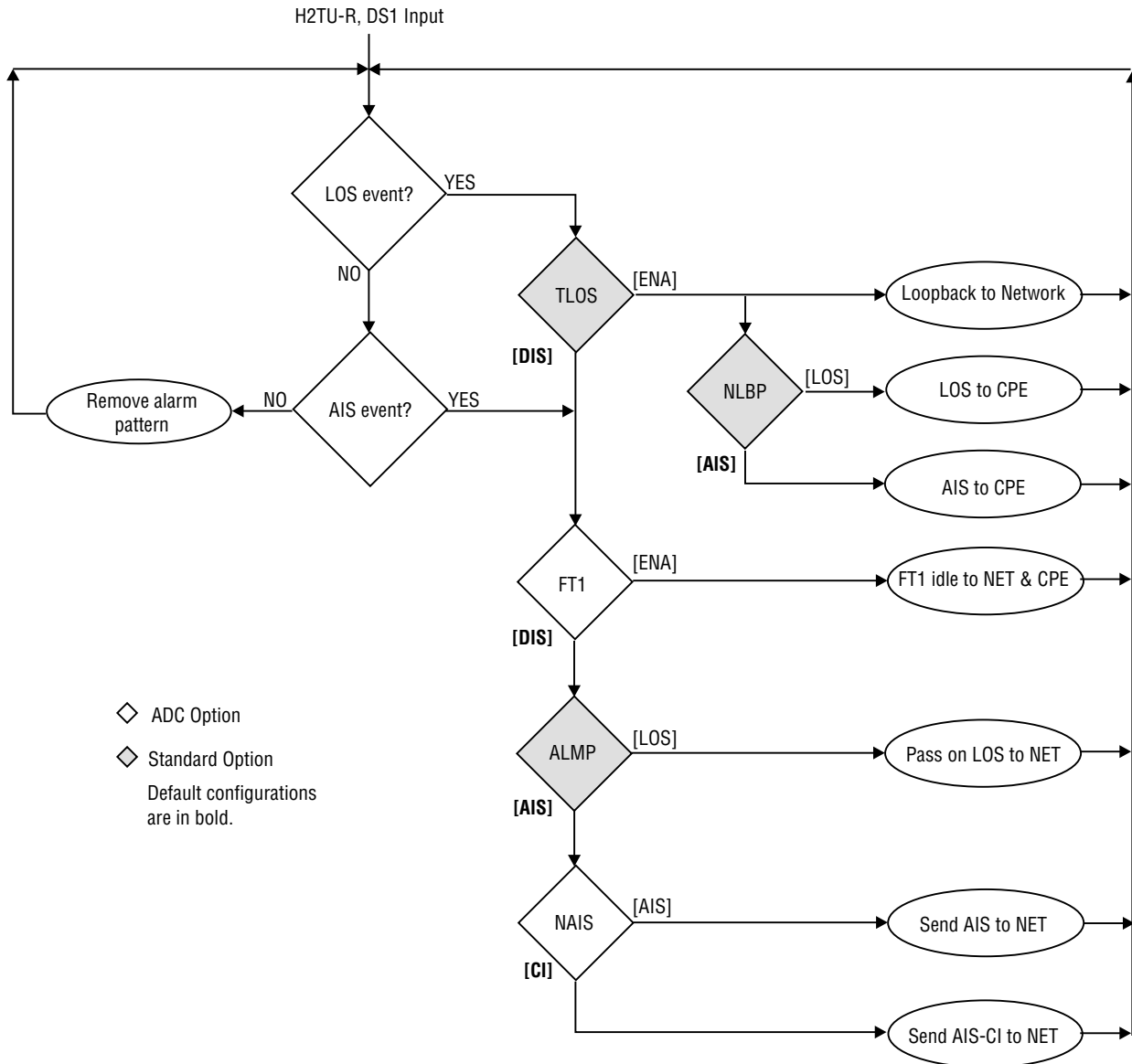

Figure 26. H2TU-R LOS and AIS Response Priorities

OCT55 TEST PATTERN WITH AMI CODE

The OCT55 test pattern can be used in unframed mode to stress the system and verify data integrity. In an SF or ESF framing mode, excessive zero anomalies may occur which cause the H2TU-C to report ES, SES, and UAS errors according to ANSI T1.231-1997.

LOOPBACK OPERATION

HiGain HDSL2 has a family of loopback options for analyzing circuit functionality. The loopback signal is transmitted and returned to the sending device for comparison. This allows you to verify the integrity of the HDSL2 channels to the H2TU-C, the H2TU-C DSX-1 interface, and the DS1 channels to the customer. Loopback options include:

- Generic Loopback (GNLB) commands (see [Table 22 on page 48](#))
- Special Loopback (SPLB) commands (see “[Special Loopback Commands](#)” on page 48) and the following command tables:
 - Addressable Repeater Loopback commands: A2LB (see [Table 23 on page 52](#))
 - Addressable Repeater Loopback commands: A3LB, A4LB (see [Table 24 on page 54](#))
- SmartJack (SMJK) Loopback commands (see [Table 25 on page 54](#))

Loopback commands can be initiated by:

- Selecting the loopback type using the MODE and SEL pushbuttons on the H2TU-C front panel or the manual loopback (LBK) pushbutton on the H2TU-R
- Selecting the loopback type from the Monitor menu when connected to the craft port of the H2TU-C or H2TU-R
- Entering the loopback code into the test equipment connected to the H2TU-C or H2TU-R.

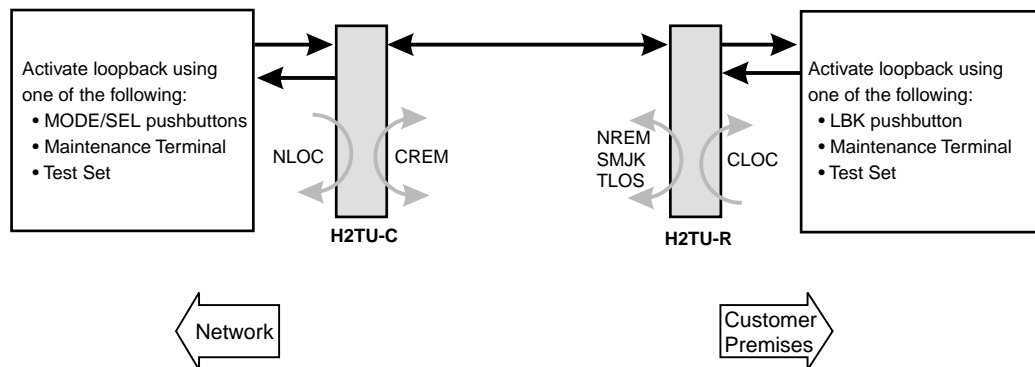

Figure 27. Loopback Summary



HiGain supports multiple loopbacks, but a single loopback is the preferred method.

Generic Loopback Commands

The HiGain HDSL2 Generic Loopback (GNLB) commands allow you to use in-band codes to loop up either NLOC (4-in-7) or NREM (3-in-7) towards the network. In addition, these in-band codes loop up CREM (6-in-7) or CLOC (5-in-7) towards the customer. Either loopup condition can be terminated (looped down) with the 3-in-5, SMJK loopdown code. All in-band codes must be present for at least 5 seconds before the HiGain HDSL2 system responds. TLOS is a logic loopback caused by loss of the DS1 input from the CI.

Figure 28 on page 51 summarizes the available loopbacks in the system, and Table 22 summarizes the HiGain HDSL2 generic loopback commands. See “GNLB Test Procedures” on page 50 for the test procedures that apply when using the GNLB mode.

Table 22. Summary of HiGain HDSL2 Generic Loopback Codes and Activation Methods

Loopback	Code	Description	Method of Activation		
			Test Set	Craft Port	MODE/SEL
NLOC	1111000 4-in-7	DSX-1 signal is looped back to the network at the H2TU-C.	X	X	X
NREM	1110000 3-in-7	DSX-1 signal is looped back to the network at the H2TU-R.	X	X	X
CLOC	1111100 5-in-7	DS1 signal from the customer is looped back to the customer at the H2TU-R.	X	X	X
CREM	1111110 6-in-7	DS1 signal from the customer is looped back to the customer at the H2TU-C.	X	X	X

Special Loopback Commands

In addition to the GNLB loopback command mode, a HiGain HDSL2 system can be configured for one of three special loopback command modes. These are selected from the maintenance terminal Config menu, ADC Options screen (see Table 6 on page 18) or by using the MODE and SEL pushbuttons (see Figure 28 on page 51). Once a loopback mode is activated, other loopback commands can be sent by a test set connected to the craft port of the H2TU-C or H2TU-R (see Table 23 on page 52 and Table 24 on page 54 for list of SPLB commands).

A2LB through A4LB are special, addressable, repeater loopback modes that are supported by the H2TU-C-231. These loopback modes provide the HiGain HDSL2 system with sophisticated maintenance and troubleshooting tools. A2LB is patterned after the Teltrend addressable T1 repeater loopbacks. A3LB and A4LB are patterned after the Wescom addressable T1 repeater loopbacks.

All three SPLBs have been enhanced to handle the specific requirements of the following HiGain HDSL2 customers:

- A2LB (Teltrend) = Southwestern Bell
- A3LB (Wescom) = New England Telephone, Bell Atlantic
- A4LB (Wescom Mod 1) = New York Telephone

A2LB can be configured to do one of the following:

- Block the arming code (after 2 seconds) from exiting the H2TU-C into the network, and replace it with the AIS code.
- Unblock the AIS code by executing the Far End Activate code.

A3LB and A4LB are identical because all of the SMJK loopup and loopdown commands are under control of the LPBK setting.

SmartJack Loopback Commands

The HiGain HDSL2 SmartJack (SMJK) Loopback (LPBK) commands allow you to use in-band, out-of-band, and universal codes to initiate and terminate loopback testing of the HiGain HDSL2 circuit. (See “[SmartJack Test Procedure](#)” on page 54 for additional information.)

MANUAL LOOPBACK SESSION

A manual loopback session allows you to select any one of the HiGain HDSL2 loopbacks listed in [Table 22](#) on page 48.

Setting the Loopback Time-Out Option

Before initiating a loopback session, verify that the loopback time-out parameter is set to the desired setting.

- 1 Use the MODE and SEL pushbuttons as described in “[Setting Options through MODE and SEL](#)” on page 9. (The loopback time-out parameter is also user-selectable from the Config menu, Standard Options screen when using a maintenance terminal.)
- 2 Select the desired setting:
 - NONE (time-out disabled)
 - 20 minutes
 - 60 minutes
 - 120 minutes (default setting)

Activating Manual Loopback Mode



With the exception of SmartJack, any of the HiGain HDSL2 loopbacks can be executed using the MODE and SEL pushbuttons.

When executing a manual loopback session using the MODE and SEL pushbuttons:

- The next loopback option can be displayed by pressing the MODE pushbutton, however, the previously activated loopback remains active until the SEL pushbutton is pressed, which activates the new loopback.
- If neither pushbutton is pressed for a period of 30 seconds and no loopback is in effect, the manual loopback session terminates, and the display returns to normal mode.
- If any loopback is in effect, the 30-second time-out is inhibited. The active loopback and the manual loopback sessions continue until the loopback times out in accordance with the LBTO setting.
- If there is an active loopback, pressing the MODE and SEL pushbuttons for 3 or more seconds terminates any active loopback, ends the manual loopback session, and returns the display to normal mode.

To initiate a manual loopback session:

- 1 Press both the MODE and SEL pushbuttons on the front panel for at least 3 seconds. The following message appears on the front-panel display:

```
MAN LPBK NLO?
```
- 2 Press SEL to activate NLOC. The display changes to `MAN LPBK NLOC`.

- 3 Press MODE to advance to the next available loopback:
 - NRE? = NREM
 - CRE? = CREM
 - CLO? = CLOC
- 4 Press SEL to activate the selected loopback. The previous loopback is terminated.

Once a loopback is selected and activated, the loopback stays active until it times out (based on the LBTO setting). When a loopback times out, the display then returns to the normal display mode.

You can terminate loopbacks manually and exit the MAN LPBK mode by simultaneously pressing the MODE and SEL pushbuttons for 3 or more seconds. If no loopback is active, the MAN LPBK mode automatically terminates after 30 seconds.

All loopbacks can be initiated by in-band commands in the DS1 payload or by a command from the HiGain HDSL2 system (front-panel pushbuttons or maintenance screen selections). Therefore, whenever a loopback is active, the method by which it was activated is indicated in the loopback and status information (Monitor screen) by the annotation HG or PL adjacent to the identified loopback. For example, NREM-HG indicates that the loopback was initiated by the HiGain HDSL2 system.



SMJK loopback commands are only activated by in-band commands.

IN-BAND LOOPBACK SESSIONS

The following sections provide step-by-step test procedures for verifying the integrity of the HDSL2 channels at every module location as well as the DS1 channels to the customer and the local DSX-1 interface.

General Troubleshooting Tips

If trouble is encountered on the DSX-1 interface of the H2TU-C, verify that the:

- H2TU-C is making a positive connection with its mounting-assembly (shelf) connector.
- H2TU-C internal equalizer is set to the correct distance range per [Table 6 on page 18](#). All equalizers should be set to the distance from the DSX-1 to the shelf.

The transmit and receive DSX-1 ports have splitting access jacks and miniature 210-series, bridging jacks as shown in [Figure 1 on page 3](#). Connecting one cable between the two BRG jacks and another between the two LINE jacks splits the IN and OUT and creates metallic loopbacks towards both the DSX-1 and the H2TU-C-231. If separate plugs are inserted into both LINE jacks with the other end disconnected, the BRG jacks can be used to send and receive test patterns towards the DSX-1.

GNLB Test Procedures

[Figure 28 on page 51](#) is a graphical representation of the various loopback configurations with the associated GNLB commands shown. Refer to [Table 22 on page 48](#) for a description of these commands.

To perform the GNLB loopback test procedure:

- 1 Have the CO tester send the NREM (3-in-7) in-band loopup code for 5 seconds. You should be able to observe the NREM message on the front-panel display. (The Status LED on the front panel should be green, and the loopback mode should also be identified on the Monitor screen.)
- 2 Have the CO tester transmit a DS1 test signal towards the H2TU-C and verify that the returned (looped) signal to the test set is error-free.

- 3 If step 2 fails, have the CO tester transmit the 3-in-5 in-band loopdown code.
- 4 Have the CO tester send the NLOC (4-in-7) in-band loopup for 5 seconds. You should be able to observe the NLOC message on the front-panel display. (The Status LED on the front panel should be yellow, and the loopback mode should also be identified on the Monitor screen.)
- 5 Repeat Step 2. If the test passes, the problem is in the downstream direction. If it fails, the problem is in the upstream direction.

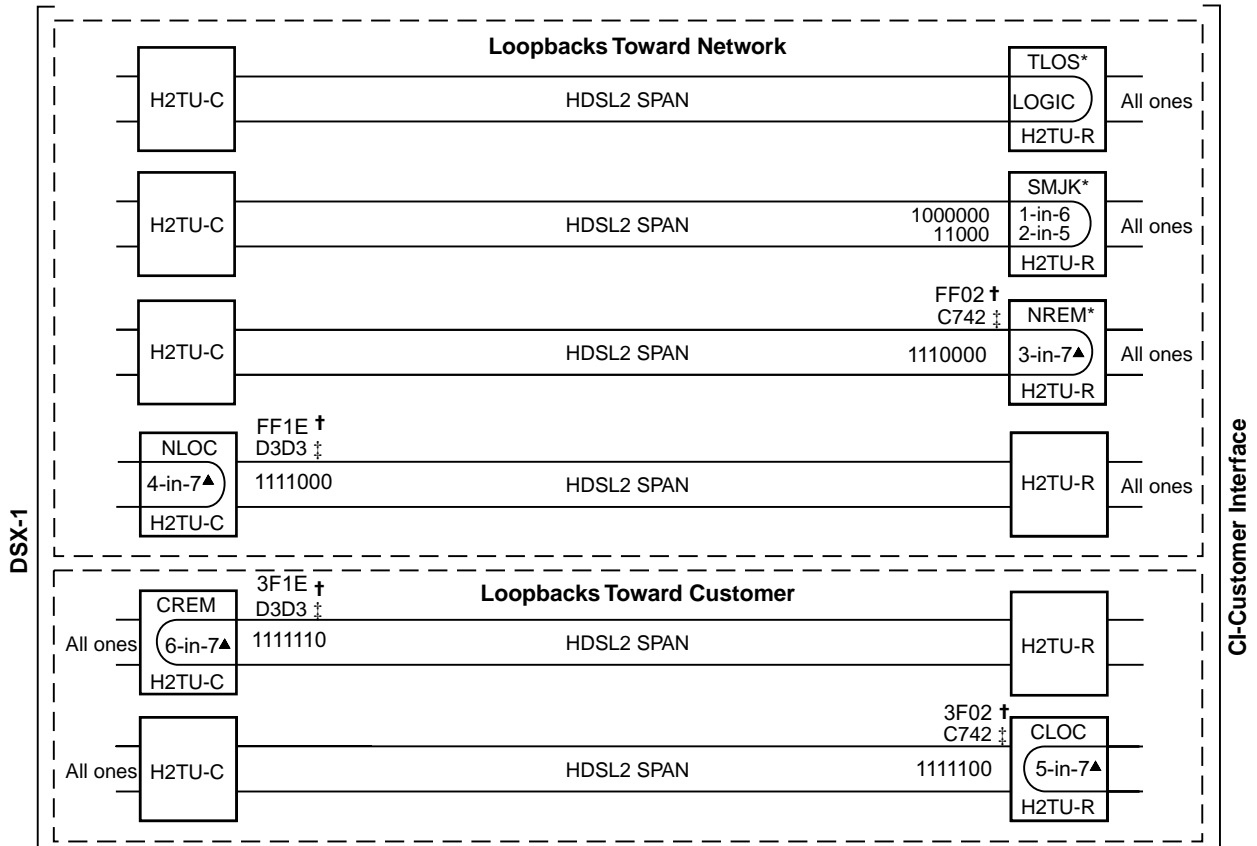

* Set the NLBP option to AIS to send AIS (indicated by an all ones pattern) for any network loopback.
 † A3LB and A4LB loopback codes.
 ‡ A2LB loopback code.
 ▲ GNLB loopback codes.

Figure 28. Loopback Modes

A2LB Test Procedures

Using the codes listed in [Table 23](#), a network tester can activate NLOC or NREM loopbacks (or SMJK, if enabled). A tester at the customer premises can activate CLOC or CREM loopbacks. All loopbacks shown in [Table 23](#) can also be initiated from the H2TU-C front-panel MODE and SEL pushbuttons (see “[Setting Options through MODE and SEL](#)” on page 9).

Table 23. *Addressable Repeater Loopback Commands (A2LB)*

Loopback	Binary Code ^(a) (Hexadecimal Equivalent)	Description
ARMING or NI LPBK (in-band)	11000-11000 ...	Arming code
ARMING or NI LPBK (ESF Data Link)	1111-1111-0100-1000 (FF48)	Arming code
IR LPDN or DISARM (in-band)	11100-11100 ...	Disarming code
IR LPDN or DISARM (ESF Data Link)	1111-1111-0010-0100 (FF24)	Disarming code
IOR LPBK (NLOC or CREM) 230-232 bit errors 229-231 bit errors ^(b)	1101-0011-1101-0011 (D3D3)	NLOC—DSX-1 signal is looped back to the network at the H2TU-C. CREM—DS1 signal from customer is looped back to the customer at the H2TU-C.
ILR-2 LPBK (NREM or CLOC) 20 bit errors ^(c)	1100-0111-0100-0010 (C742)	NREM—DSX-1 signal is looped back to the network at the H2TU-R. CLOC—DS1 signal from customer is looped back to the customer at the H2TU-R.
IR LPDN (except SMJK)	1001-0011-1001-0011 (9393)	Loopdown (H2TU-C or H2TU-R)
IR QUERY LPBK	1101-0101-1101-0101 (D5D5)	Query loopback
IR ALTERNATE QUERY LPBK	1101-0101-1110-1010 (D5EA)	Alternate query loopback
TIME-OUT OVERRIDE	1101-0101-1101-0110 (D5D6)	Loopback time-out override
FAR END NI ACTIVATE	1100-0101-0101-0100 (C554)	Unblock AIS
IOR POWER DOWN (H2TU-C) ^(d)	0110-0111-0110-0111 (6767)	Removes HDSL2 line power

(a) The leftmost bit arrives first in all sequences. The detection algorithm functions reliably with a random 10^{-3} Bit Error Rate (BER) on the facility. The entire arming and loopback sequence can also be initiated at the remote H2TU-R location.

(b) The H2TU-R identifies CREM (and the H2TU-C identifies NLOC) with 231 bit errors, excluding the frame bits. When framed data is being sent in the AUTO framing mode, the number of the 231 bit errors detected by the test set varies from 229 to 231, depending on whether or not the test set counts frame errors as bit errors, and on the number of frame bits contained in the block of 231 error bits. The H2TU-R and H2TU-C generate this bit pattern in a series of discontinuous bursts containing 20-bit errors each, excluding frame bits. Those test sets that do not count frame error bits as data bit errors will indicate fewer bits than the H2TU-R and H2TU-C transmit for a CI and NI loopback.

(c) The H2TU-R is assigned the ILR-2 loopback code. It responds with 20 bit errors (excluding the frame bits).

(d) The IOR Power Down code must remain present for the duration of the powerdown mode. When this code is removed, the HiGain system returns to its normal unlooped and unarmed state.

To perform the A2LB test procedures:

- 1 Send the in-band Arming and NI LPBK code 11000 to the H2TU-C for at least 5 seconds.
- 2 Monitor the output of the H2TU-C for the return of the pattern. Return of the pattern indicates one of the following:
 - The H2TU-R has looped up (if the SMJK Loopback option is enabled)
 - An external NID has looped up (if the SMJK Loopback option is disabled), and the H2TU-C and H2TU-R have been armed.
- 3 Verify, if possible, that the H2TU-R Loopback LED is either flashing yellow at four times per second (indicating that the system is armed), or is a steady yellow (indicating that it is both armed and in SMJK loopback). The H2TU-C Status LED also flashes yellow when the system is armed.



If the Arming code is not returned after 5 seconds, the system may be armed, but there is no active loopback.

- 4 Once armed, the H2TU-C can be looped back by sending Intelligent Office Repeater (IOR) LPBK activation code 1101-0011-1101-0011 (D3D3) for at least 5 seconds. You should observe the following activation response pattern:
 - a 2 seconds of AIS (all ones pattern)
 - b 2 seconds of returning data pattern
 - c Logic errors (including the frame bit) occurring in the returned pattern comprising:
 - 231 errors, if IOR LPBK (H2TU-C) was sent
 - 20 errors, if ILR-2 (H2TU-R) was sent
 - d Normal looped data

This error pattern repeats every 20 seconds as long as the IOR loopback pattern is being sent. This also applies to ILR, Time-Out Override, and Query commands.



Some Intelligent Repeater (IR) test sets do not count frame errors as bit errors when the test pattern is framed and the H2TU-C-231 is set to the Auto framing mode. To improve compatibility with those test sets, the H2TU-C generates 231 (NLOC and CREM) ID bit errors. As a result, the H2TU-C may indicate one more or one less bit error, depending on the test set type and the number of frame bits contained in the block of errored bits. To avoid this uncertainty, ADC recommends sending unframed IR commands.

The H2TU-C is now in logic loopback if the IOR NLOC loopback command was sent. The Time-Out Override command or a Loopdown command can override the selection made for the loopback time-out (see [“Setting the Loopback Time-Out Option” on page 49](#)). If the Time-Out Override code 1101-0101-1101-0110 (D5D6) is received after activating a loopback, then the automatic timed expiration of the loopback is inhibited. If this Time-Out Override is sent, then the only way to loop the H2TU-C down is to do one of the following:

- Issue the IR loopdown (LPDN) code 1001-0011-1001-0011 (9393)
- Issue the NI LPDN and Disarm in-band code 11100 or the ESF FDL code (FF24).



The Time-Out Override function is only valid for the current active loopback. The automatic time-out timer is restored during subsequent loopback sessions.

- 5 Once the test is complete, do one of the following:
 - If the system is to loop down but remain armed, send the IR LPDN code.
 - If all the equipment is to be looped down, disarmed, and returned to normal operation, send the disarm in-band code 11100 or the ESF FDL code (FF24).



The Armed mode has an automatic time-out of 120 minutes, but this timer is reset to 120 for any of the following events:

- Loopback terminates (manually or time-out)
- Query
- Alternate query
- Far End activate
- Another ARM command

This timer is inhibited while any of the valid command codes are being sent. Once the codes are removed, the timer restarts at 120.

A3LB and A4LB Test Procedures

The H2TU-C-231 can be looped back by sending the Addressable Office Repeater (AOR) LPBK activation code 1111-1111-0001-1110 (FF1E) for at least 5 seconds. This causes the H2TU-C to enter the NLOC state. The Loopback Time-Out setting (see “[Setting the Loopback Time-Out Option](#)” on page 49) determines the duration of this loopback unless it is overridden by the reception of a second identical 16-bit loopup command before the timer expires. When this time-out override state exists, the only way to loop the H2TU-C down is to issue one of the three loopdown commands listed in [Table 25](#) on page 54. The automatic time-out mode is restored during subsequent loopback sessions.

[Table 24](#) summarizes the codes required to execute Addressable 3 (A3LB) and Addressable 4 (A4LB) repeater loopback commands which are identified in the List 4E HDSL2 products. All code sequences must be present for at least 5 seconds.

Table 24. Addressable Repeater Loopback Commands (A3LB and A4LB)

Name	Description	Binary Code ^(a) (Hexadecimal Equivalent)
NLOC	H2TU-C loopup from NI	1111-1111-0001-1110 (FF1E)
CREM	H2TU-C loopup from CI	0011-1111-0001-1110 (3F1E)
NREM	H2TU-R loopup from NI	1111-1111-0000-0010 (FF02)
CLOC	H2TU-R loopup from CI	0011-1111-0000-0010 (3F02)

(a) The leftmost bit arrives first in all sequences. The detection algorithm functions reliably with a random 10^{-3} Bit Error Ratio (BER) on the facility. The entire arming and loopback sequence can also be initiated at the remote H2TU-R location.

SmartJack Test Procedure

The HiGain H2TU-R supports the standard SmartJack loopback which can emulate a Network Interface Device (NID) for the purpose of loopback testing of the HiGain HDSL2 circuit. SMJK and NREM loopbacks perform the same functions, but their initiation differs. SMJK indicates that the loopback was initiated by any of the three SmartJack loopup commands listed in [Table 25](#). NREM, on the other hand, is initiated by the 3-in-7 in-band command or by a command issued from the maintenance terminal.

The SmartJack loopback option, LPBK, enables or disables the ability of the H2TU-R to emulate the family of SmartJack loopback commands listed in [Table 25](#).

Table 25. SmartJack Loopup and Loopdown Commands

In-band 2-in-5 Loopup Code	In-band 3-in-5 Loopdown Code ^(a)	Out-of-Band ESF FDL Loopup Codes	Out-of-Band ESF FDL Loopdown Codes ^(a)	In-band 1-in-6 Loopup Code	In-band 1-in-3 Loopdown Code ^(a)
11000	111000	1111-111-0100- 1000	1111-1111-0010-0100	100000	100

(a) These universal loopdown codes can release any and all existing loopup states regardless of loopback direction or method of initiation. The codes are permanently enabled and independent of all loopback option settings, including the LPBK option.

APPENDIX A - SPECIFICATIONS

Power

HDSL2 Span Voltage	0 or -180 Vdc \pm 5 Vdc
CO Supply	-48 Vdc nominal (-42.5 to -56.5 Vdc) (See "Power Consumption", "Maximum Power Dissipation", and "Maximum Current Drain" on page 56.)
Electrical Protection	Secondary surge and power cross-protection on HDSL2 ports. Requires external primary protection.
Fusing	Internal; connected to fuse alarm output on pin 32

Environmental

Operating Temperature	-40°F to +149°F (-40°C to + 65°C)
Operating Humidity	5% to 95% (non-condensing)

Physical

Height	5.9 in. (15.0 cm)
Width	1.4 in. (3.5 cm)
Depth	10.0 in. (25.4 cm)
Weight	8.0 oz. (0.23 kg)
Mounting	220 mechanics

HDSL2

Line Rate	1.552 Mbps Overlapped Pulse Amplitude Modulation Transmission with Interlocking Spectra (OPTIS)
Transmission	Full duplex
Media	One non-loaded, copper, two-wire cable pair
Output	+16.8 dBm \pm 0.5 dBm at 135 Ω (0-450 kHz) at CO side; +16.5 dBm \pm 0.5 dBm at 135 Ω (0-350 kHz) at remote side
Line Impedance	135 Ω
Maximum Loop Attenuation	35 dB at 196 kHz, 135 Ω
Start-up Time	30 sec. (typical), 1 min. (maximum) per span

DSX-1

Line Impedance	100 Ω
Line Rate	1.544 Mbps \pm 200 bps
Line Format	Alternate Mark Inversion (AMI) or Bipolar with 8-Zero Substitution (B8ZS)
Frame Format	Extended SuperFrame (ESF), SuperFrame (SF), or Unframed (UNFR)
Pulse Output	6 V ^{pk-pk} pre-equalized for 0 to 655 feet of ABAM cable
Input Level	+1.5 to -7.5 dB DSX

System

One-way DS1 Delay	<400 μ s
Wander (Looped)	Meets MTIE T1.101 requirements
Wideband Jitter (Looped)	0.2 UI maximum
Narrowband Jitter (Looped)	0.1 UI maximum

POWER CONSUMPTION

The three most important power parameters of an H2TU-C are its maximum power consumption, maximum power dissipation, and maximum current drain.

Table 26 describes line-powered and locally powered (remote) circuits on 9 kft, 26 AWG loops.

Table 26. H2TU-C Power Parameters

	-48 Vdc Power Consumption (Watts)	Heat Dissipation (Watts)	-42.5 Vdc Current (mA)
Remote Power Source	Maximum	Maximum	Maximum
Line-powered	12.0	7.0	286.0
Locally powered (sealing current on)	8.6	6.7	205.0

MAXIMUM POWER DISSIPATION

The maximum power dissipation measures the power that is converted into heat that builds up within the unit. It contributes to the total heat generated in the space around the unit. It is used to determine the maximum number of fully loaded shelves per bay that does not exceed the maximum allowable power dissipation density in watts per square foot to comply with GR-63.

In COs, the maximum power dissipation for open-faced, natural convection-cooled mountings is limited to 134.7 watts per square foot in accordance with GR-63-CORE. The footprint of a standard 28-slot, 23-inch HCS-417 shelf is 7.024 square feet. Therefore, the maximum bay dissipation is limited to 946 watts. Use this limit and the parameters in Table 26 to determine the maximum number of H2TU-C circuits that can occupy one CO bay.



This is a worst case situation since it assumes the entire CO is subjected to the maximum power density. More favorable conditions would permit increasing the number of shelves per bay without jeopardizing the CO thermal integrity.

The thermal loading limitations imposed when using the H2TU-C in a Controlled Environmental Vault (CEV) or other enclosures are determined by applying its power parameters to the manufacturer's requirements for each specific housing.

The -48 Vdc power consumption is the maximum total power that the H2TU-C consumes or draws from the shelf power source. This parameter is needed when the H2TU-C is in a location remote to the CO it is serving. It determines the battery capacity required to maintain an 8-hour, standby battery reserve for emergency situations. Battery capacity, therefore, limits the maximum number of line units which can be installed in a remote enclosure. Use the data in Table 26 to perform this analysis.

MAXIMUM CURRENT DRAIN

The maximum current drain is the maximum current drawn from the shelf power supply when it is at its minimum voltage (-42.5 Vdc). This determines the shelf fusing requirements. Use the -42.5 Vdc current data in Table 26 to determine the shelf fusing requirements for your particular H2TU-C applications.

LOOP ATTENUATION

Each loop has no more than 35 dB of loss at 196 kHz, with driving and terminating impedances of 135Ω (see [Table 27](#) below).

Table 27. HDSL2 Cable Attenuation Chart

Cable Gauge	Loss at 196 kHz (dB/kft)	Ω per kft
26/0.4 mm	3.88	83
24/0.51 mm	2.84	52
22/0.61 mm	2.18	32
19/0.91 mm	1.54	16

H2TU-C-231 LIST 4E CARD-EDGE CONNECTOR

Figure 29 shows the card-edge connectors on the H2TU-C-231 List 4E. Active pins are highlighted in black.

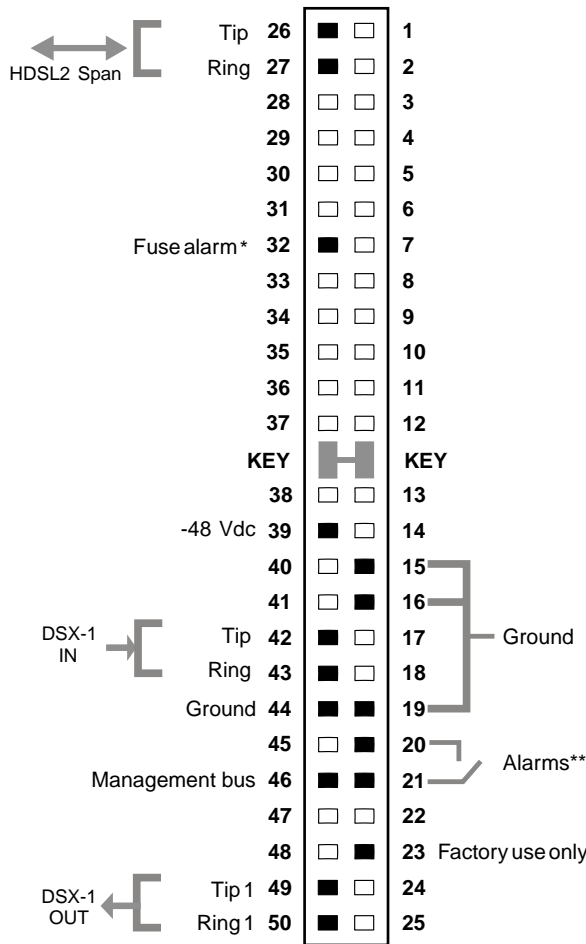

* Fuse alarm is normally floating and at -48 Vdc when activated.
 ** System minor alarm contacts (pins 20 and 21) are normally open, and close upon alarm.

Figure 29. H2TU-C-231 List 4E Card-Edge Connector

Network Management Control Bus

The H2TU-C provides a Network Management Control Bus on pin 46 of the card-edge connector. This allows the various management system protocols to manage the H2TU-C through the H2TU-319 HiGain Management Unit. Whenever the H2TU-C is under management, the MNGD message appears periodically on the front-panel display.



Some H2TU-C-231 List 4E features are affected when it is under management. Consult the management unit practice for further information (see “Appendix D - Product Support” on page 63).

Fuse Alarm

Pin 32 on the card-edge connector is a fuse alarm that is driven to -48 Vdc through a diode whenever the onboard fuse opens.

System Alarm Output Pins

Pins 20 and 21 on the card-edge connector (see [Figure 29 on page 58](#)) are the H2TU-C-231 System Alarm output signals

CRAFT PORT

[Figure 30](#) shows the pinout for the craft port connector and its connection to a DB-9 or DB-25 connector on a maintenance terminal.

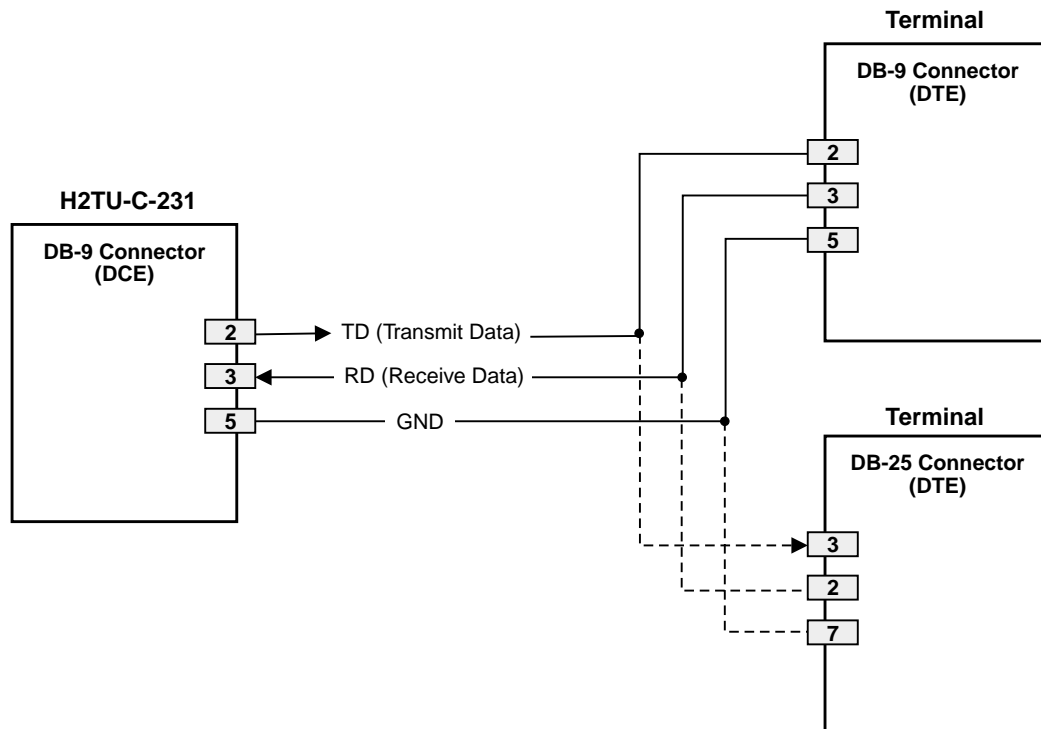

Figure 30. RS-232 Craft Port Pinouts

APPENDIX B - FUNCTIONAL OPERATION

ADC's HDSL2 technology provides full-duplex services at standard DS1 rates over copper wires between an H2TU-C and an H2TU-R, which comprise one HiGain HDSL2 system. HiGain HDSL2 systems use Overlapped Pulse Amplitude Modulation Transmission with Interlocking Spectra (OPTIS) transceiver systems to establish full-duplex, 1.552 kbps data channels between the H2TU-C-231 and a remotely located H2TU-R.

A block diagram of the H2TU-C-231 is shown in Figure 31. The H2TU-C-231 receives a 1.544 Mbps DSX-1 data stream from the DSX-1 digital cross-connect interface. The H2TU-C contains a DS1 frame synchronizer controlled by an 8-bit microprocessor that determines the type of framing on the DS1 stream and synchronizes with it. The H2TU-C recognizes Superframe (SF) or Extended Superframe (ESF) framing. When the data is unframed, the H2TU-C arbitrarily defines a frame bit.

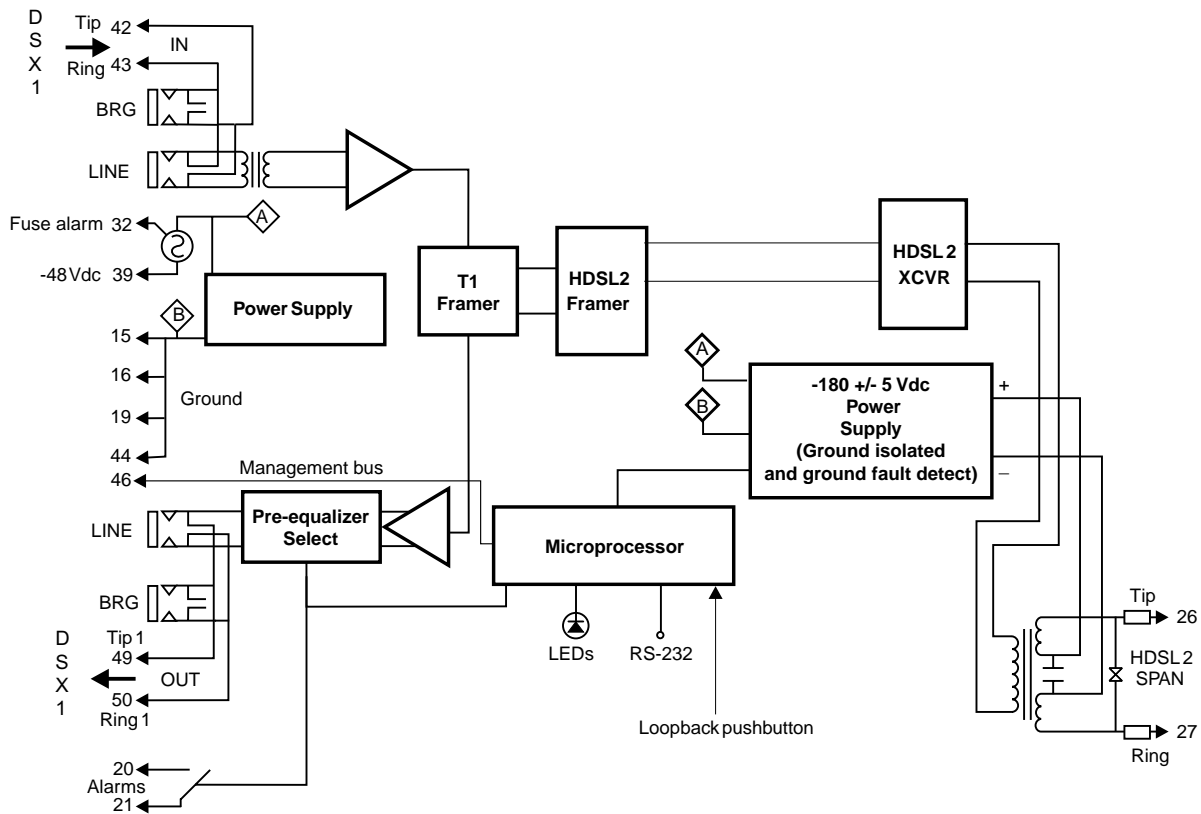

Figure 31. H2TU-C-231 List 4E Block Diagram

TIMING

The low-loop wander (0.5 UI max) of an H2TU-C, when used with remote units, allows the circuit to be used in all critical timing applications, including those used to transport Stratum 1 timing.

GROUND FAULT DETECT

The H2TU-C has a Ground Fault Detect (GFD) circuit which detects a ground or a resistive path to ground on any wire of the HDSL2 loop. This makes the product compliant with the Class A2 requirements of GR-1089.

APPENDIX C - COMPATIBILITY

The HiGain HDSL2 system uses HDSL2 transmission technology as recommended by Bellcore TA-TSY-001210. HiGain HDSL2 complies with GR-63-CORE, TR-TSY-000499, and GR-1089-CORE.

The H2TU-C-231 List 4E is compatible with the following T1 repeater shelves and associated equipment:

- HiGain Card Shelf HCS-417 (23" shelf)
- HiGain Card Shelf HCS-418 (19" shelf)
- HiGain Card Shelf HCS-402 (2-slot)
- AT&T 220 Office Repeater Bay (ORB)
- AT&T Small Cross-Section Shelf (SXSS)
- Kentrox 220 (The ALM option must be disabled to resolve a conflict between the H2TU-C alarm relay output and the Kentrox external equalizer output. Both use pins 20 and 21.)
- Wescom® 342-30

APPENDIX D - PRODUCT SUPPORT

ADC Customer Service Group provides expert pre-sales and post-sales support and training for all its products.

TECHNICAL SUPPORT

Technical support is available 24 hours a day, 7 days a week by contacting the ADC Technical Assistance Center (TAC) at one of the following numbers:

Telephone:	800.638.0031 or 714.730.3222 The 800 line is toll-free in the USA and Canada.
Fax:	714.832.9924
Email:	wsd_support@adc.com
Online:	www.adc.com/knowledge_base_frames

RETURNS

To return equipment to ADC:

- 1 Locate the purchase order number under which the equipment was purchased. You will need to provide this number to ADC Customer Service to obtain a return authorization.
- 2 Call ADC Customer Service to ask for a Return Material Authorization (RMA) number and instructions before returning products. Use the telephone number, fax number, or email address listed below:
 - Telephone: 800.366.3891 ext. 63748 or 952.946.3748
The 800 line is toll-free in the USA and Canada.
 - Fax: 952.946.3237
 - Email Address: repair&return@adc.com
- 3 Be prepared to provide the following information:
 - Company name, address, telephone number, and the name of a person Customer Service can contact regarding this equipment.
 - A description of the equipment as well as the number of units that you are returning. Be sure to include the model and part number of each unit.
 - The shipping address to which Customer Service should return the repaired equipment.
 - The reason for the return.

APPENDIX E - ABBREVIATIONS

A

ACO: Alarm Cutoff
ACON: Auto Conversion of DS1 frame
AIS: Alarm Indication Signal
AIS-CI: Alarm Indication Signal-Customer Installation
AMI: Alternate Mark Inversion
AUTO: Auto-Framing Mode
AWG: American Wire Gauge

B

B8ZS: Bipolar with 8-Zero Substitution
BER: Bit Error Rate
BPV: Bipolar Violation
BPVT: Bipolar Violation Transparency
BRG: Bridge

C

CLEI: Common Language Equipment Identifier
CLOC: Customer Local Loopback
CO: Central Office
CPE: Customer Premises Equipment
CRC: Cyclical Redundancy Check
CREM: Customer Remote Loopback
CV: Code Violation

D

DBER: DS1 Bit Error Rate
DDS: Digital Data Service
DL: Datalink
DLC: Digital Loop Carrier
DS0: Digital Signal, Level 0
DS1: Digital Signal, Level 1
DSX-1: DS1 Cross-Connect Frame

E

ECI: Equipment Catalog Item

ES: Errored Seconds
ESD: Electrostatic Discharge
ESF: Extended SuperFrame
EXZ: The occurrence of 8 consecutive zeroes for B8ZS or 16 for AMI

F

FCON: Framed Conversion of DS1 frame
FDL: Facility Datalink
FE: Far End
FT1: Fractional T1

G

GNLB: Generic Loopback

H

H2TU-R: HiGain HDSL2 Remote Unit
HBER: HDSL2 Block Error Rate
HCDS: High Capacity Digital Service
HCS: HiGain Card Shelf
HDSL2: High-bit-rate Digital Subscriber Line 2
HG: HiGain

I

ID: Identifier
IN: Transmit
IOR: Intelligent Office Repeater

L

LA: Loop Attenuation
LED: Light Emitting Diode
LOF: Loss of Frame
LOS: Loss of Signal
LOSW: Loss of Sync Word
LPF: Line Power Feed

M**MNGD:** Managed**MSEC:** Monitored Seconds**N****NE:** Near End**NI:** Network Interface**NIU:** Network Interface Unit**NLOC:** Network Local Loopback**NMA:** Network Management and Administration**NPRM:** Network Performance Report Messaging**NREM:** Network Remote Loopback**NVRAM:** Non-Volatile Random Access Memory**O****OOF:** Out-of-Frame**OPTIS:** Overlapped Pulse Amplitude Modulation Transmission
with Interlocking Spectra**ORB:** Office Repeater Bay**OUT:** Receive**P****PBOC:** Power Back Off Customer**PBON:** Power Back Off Network**PDVS:** Pulse Density Violation Seconds**PL:** Payload Loopback Command**PRM-FE:** Performance Report Messaging - Far End**PRM-NE:** Performance Report Messaging - Near End**PWRF:** Power Feed**R****RA:** Remote Alarm Indication**RAIS:** Remote Alarm Indication Signal**RLOS:** Remote Loss of Signal**S****SES:** Severely Errored Seconds**SF:** SuperFrame**SMJK:** SmartJack**SPLB:** Special Loopback**SPRM:** Supplemental Performance Report Messaging**T****TLOS:** Transmit Loss of Signal**U****UAS:** Unavailable Seconds

CERTIFICATION AND WARRANTY

FCC CLASS A COMPLIANCE

This equipment has been tested and found to comply with the limits for a Class A digital device, pursuant to Part 15 of the FCC Rules. These limits are designed to provide reasonable protection against harmful interference when the equipment is operated in a commercial environment. This equipment generates, uses, and can radiate radio frequency energy and, if not installed and used in accordance with the instruction manual, may cause harmful interference to radio communications. Operation of this equipment in a residential area is likely to cause harmful interference in which case the user will be required to correct the interference at his own expense.

LIMITED WARRANTY

ADC DSL Systems, Incorporated (“ADC”) warrants that, for a period of sixty (60) months from the date of shipment, the hardware portion of its products will be free of material defects and faulty workmanship under normal use. ADC’s obligation, under this warranty, is limited to replacing or repairing, at ADC’s option, any such hardware product which is returned during the 60-month warranty period per ADC’s instructions and which product is confirmed by ADC not to comply with the foregoing warranty.

ADC warrants that, for a period of 90 days from the date of purchase, the software furnished with its products will operate substantially in accordance with the ADC published specifications and documentation for such software. ADC’s entire liability for software that does not comply with the foregoing warranty and is reported to ADC during the 90-day warranty period is, at ADC’s option, either (a) return of the price paid or (b) repair or replace of the software. ADC also warrants that, for a period of thirty (30) days from the date of purchase, the media on which software is stored will be free from material defects under normal use. ADC will replace defective media at no charge if it is returned to ADC during the 30-day warranty period along with proof of the date of shipment.

The transportation charges for shipment of returned products to ADC will be prepaid by the Buyer. ADC will pay transportation charges for shipment of replacement products to Buyer, unless no trouble is found (NTF), in which case the Buyer will pay transportation charges.

ADC may use reconditioned parts for such repair or replacement. This warranty *does not* apply to any product which has been repaired, worked upon, or altered by persons not authorized by ADC or in ADC’s sole judgment has been subjected to misuse, accident, fire or other casualty, or operation beyond its design range.

Repaired products have a 90-day warranty, or until the end of the original warranty period—whichever period is greater.

ADC DISCLAIMS ALL OTHER WARRANTIES, EITHER EXPRESS OR IMPLIED, INCLUDING BUT NOT LIMITED TO IMPLIED WARRANTIES OF MERCHANTABILITY AND FITNESS FOR A PARTICULAR PURPOSE, WITH RESPECT TO ITS PRODUCTS AND ANY ACCOMPANYING WRITTEN MATERIALS. FURTHER, ADC DOES NOT WARRANT THAT SOFTWARE WILL BE FREE FROM BUGS OR THAT ITS USE WILL BE UNINTERRUPTED OR REGARDING THE USE, OR THE RESULTS OF THE USE, OF THE SOFTWARE IN TERMS OF CORRECTNESS, ACCURACY, RELIABILITY OR OTHERWISE.

MODIFICATIONS

Any changes or modifications made to this device that are not expressly approved by ADC DSL Systems, Inc. voids the user’s warranty. All wiring external to the products should follow the provisions of the current edition of the National Electrical Code.

STANDARDS COMPLIANCE

The H2TU-C-231 List 4E has been tested and verified to comply with the applicable sections of the following safety standards:

- GR 63-CORE - Network Equipment-Building System (NEBS) Requirements
- GR 1089-CORE - Electromagnetic Compatibility and Electrical Safety
- Binational standard, UL-1950/CSA-C22.2 No. 950-95: Safety of Information Technology Equipment

For technical assistance, refer to “Appendix D - Product Support” on page 63.

ADC DSL Systems, Inc.

14402 Franklin Avenue
Tustin, CA 92780-7013

Tel: 714.832.9922

Fax: 714.832.9924

Technical Assistance

800.638.0031

714.730.3222



DOCUMENT: LTPH-TP-1034-01, ISSUE 1



1197448

